



MANGALORE REFINERY & PETROCHEMICALS LTD.

(A subsidiary of Oil & Natural Gas Corpn. Ltd – ONGC)

Regd. Office: Kuthethoor P.O., Via: Katipalla, Mangalore-575030 (India)

Phone: 0091-824-2270400 Fax: 0091-824-2271239

E-LIMITED TENDER No.: 3200000897

Date: 30.07.2024

**E-LIMITED TENDER FOR
PROCUREMENT OF VALVES FOR CONFIDENTIAL DEMO PLANT AT MRPL,
MANGALURU, KARNATAKA
AS PER TECHNICAL SPECIFICATION**

Tender Download Start Date	30.07.2024
Tender Download End Date & Time	20.08.2024; 15.00 Hrs
Pre-bid Meeting	Not Applicable
Bid Closing date & Time	20.08.2024; 15.00 Hrs
Un Priced Bid Opening date & Time	20.08.2024; 15.30 Hrs

MRPL has discontinued publication of Tender Advertisements through newspapers or any other print media.

The complete Tender/Bidding document is available for view/download on MRPL website

<https://www.tenderwizard.com/MRPL>.

Further replies to pre-bid queries, all updates, Corrigendum, Addendum, Amendments, Extension in last date of submission of bid, Clarifications etc.,(if any) to the Tender/Bidding document will be hosted on above indicated websites only. Bidders should regularly visit above indicated website to keep themselves updated.



**PROCUREMENT OF VALVES FOR CONFIDENTIAL DEMO PLANT AT
MRPL, MANGALURU, KARNATAKA**

MASTER INDEX

S. NO.	DESCRIPTION	Page No.
VOLUME-I : COMMERCIAL SECTION		
1	Cover Page	1
2	Master Index	2
3	Section - 1 :Notice Inviting Tender (NIT)	3-11
4	Section - 2 : Agreed Terms & Conditions (For Indigenous Bidders)	12-22
5	Section - 3 : Instructions To Bidders (ITB)	23-68
6	Section- 4 : Special Purchase Conditions	69-143
7	Section - 5 : General Purchase Conditions (Indigenous)	144-172
8	Section - 6 : Price Schedule	173-179
VOLUME-II : TECHNICAL SECTION		
S. NO.	DESCRIPTION	Page No.
1	Technical Notes for Valves	180-200
2	QAP	201-207



PROCUREMENT OF VALVES FOR CONFIDENTIAL DEMO PLANT AT
MRPL, MANGALURU, KARNATAKA

TENDER No: 3200000897

**PROCUREMENT OF VALVES FOR CONFIDENTIAL
DEMO PLANT AT MRPL, MANGALURU, KARNATAKA**

SECTION-1

NOTICE INVITING TENDER (NIT)



**PROCUREMENT OF VALVES FOR CONFIDENTIAL DEMO PLANT AT
MRPL, MANGALURU, KARNATAKA**

NOTICE INVITING TENDER (NIT)

M/s Mangalore Refinery & Petrochemicals Limited (MRPL) invites Tender for PROCUREMENT OF VALVES FOR CONFIDENTIAL DEMO PLANT AT MRPL, MANGALURU, KARNATAKA from eligible bidder in complete accordance with the following details and Tender document.

The brief details of the Tender are as below:

SL. No.	Description	Details
1	Tender Number	3200000897
2	Brief Description of the Tender	TENDER FOR PROCUREMENT OF VALVES FOR CONFIDENTIAL DEMO PLANT AT MRPL, MANGALURU, KARNATAKA.
3	Tender Type	E-LIMITED
4	Bid Type	Two Bid
5	Mode	Electronic Procurement System (EPS)
6	Tender Document download start date	30.07.2024
7	Bid Closing date/Time	20.08.2024 @ 15.00 Hrs (IST)
8	Date / Time of Technical Bid Opening	20.08.2024 @ 15.30 Hrs (IST)
9	Pre-bid Conference	Not Applicable
10	EMD	Not Applicable
11	Duration of Contract / Contract Period	Within 3 months (for all the items) at MRPL site from the date of issue of Purchase Order (PO).
12	Purchase Preference for Micro & Small Enterprises(MSE)	Applicable
13	Purchase Preference linked with Local content (PP-LC)	Applicable
14	Item(s) Splittable	No



**PROCUREMENT OF VALVES FOR CONFIDENTIAL DEMO PLANT AT
MRPL, MANGALURU, KARNATAKA**

15	Relaxation in PQC (Financial Turnover & Past Experience) for Start-up Companies	Not Applicable
16	Offer Validity	The offer should be valid for 60 (Sixty) days from final bid due date
17	Price Reduction Clause	Not Applicable
18	Security deposit/CPBG	Not Applicable
19	Defect Liability	Applicable
20	Integrity pact	Not Applicable
21 A	<u>Contact details</u> – Technical Queries	Section In charge: Mr. DINESH M. Email: dinesh_m@mrpl.co.in Ph. No: 0824-2882039 Dealing Officer: Mr. RAVISHANKAR MISHRA Email: ravis.mishra@mrpl.co.in Ph. No: 08242882066
B	Commercial Queries	Section In charge: Mr. Krishnaraj Bhandary M. Email: krishnaraj@mrpl.co.in Ph. No: 0824-2882040 Dealing Officer: Mr. K Hari Kumar Email: hari_kumar@mrpl.co.in Ph. No: 08242882052
22	Contact person for Queries related to E-tendering	Mr. Dilip Ranganath, Mr Jayaprakash K Email: eps@mrpl.co.in , jayaprakash.k@etenderwizard.com Phone No. 0824-288-2248/ 2298 (Dealing officer/ Section In charge details as mentioned above may also be contacted)
23	Alternate Contact details for E-Tendering	Mr. Prabhuswamy, prabhuswamy@antaressystems.com Phone No. 080-40482100
24	Address to submit the tender document (in case of other relevant documents)	Projects Department, Nethravathi building Mangalore Refinery and Petrochemicals Ltd, Mangalore -575030, Karnataka, India (Please mention tender number on the envelop)

If dates identified as (*) above happen to be a declared holiday/closed day in MRPL Mangaluru, then activity shall be conducted on next working day at 1530 Hrs (IST). The complete Bidding Document is available on MRPL website: www.mrpl.co.in and Govt. Website: <http://eprocure.gov.in/eprocure/app> Bidders can view / download the document from any one of the websites mentioned above.



**PROCUREMENT OF VALVES FOR CONFIDENTIAL DEMO PLANT AT
MRPL, MANGALURU, KARNATAKA**

Request for extension or any queries received from any bidder with less than four working days prior to bid due date shall generally be ignored, since there will not be adequate time for proper communication with client and other Bidders. Bidders shall submit the bid directly and in their own name without involving any intermediaries.

Bidders are requested to submit zero deviation bid, strictly as per terms and conditions of the Bidding Document. Bidder is required to confirm the same in the proforma provided in the Bidding Document. Stipulation or any deviation may render the bid liable for rejection.

Important information to be noted by the bidders:

- Bidders are requested to visit <https://www.tenderwizard.com/MRPL>, <http://www.mrpl.co.in> regularly to keep themselves updated. Any Revision, clarification, addendum, corrigendum, for replies to queries raised during pre-bid meeting Time / Due date extension etc., (if any) , to this TENDER would appear on the above websites only and & will not be published on any other Media /Press.
- In case of Limited Tender, new bidders those who desire to participate in the tender and meeting the Pre - qualification criteria, shall send their request through-mail to the contact person as indicated in Sl. No. 21 (B) of table above for issuing the tender enquiry / including the vendors name in tender. Bidder shall be allowed to participate till the bid closing time.
- In case of E-Tenders, the Technical & Price Bid Formats should be downloaded, filled & uploaded in the EPS portal ([https://www.tenderwizard.com/ MRPL](https://www.tenderwizard.com/MRPL))



**PROCUREMENT OF VALVES FOR CONFIDENTIAL DEMO PLANT AT
MRPL, MANGALURU, KARNATAKA**

Contact Details & Address for Site visit	
Contact Details	Address
Mr. DINESH M. (General Manager - Projects) Email: dinesh_m@mrpl.co.in Ph. No: 0824-2882039 Mr. RAVISHANKAR MISHRA Asst. Manager (Projects) Email: ravis.mishra@mrpl.co.in Ph. No: 08242882066	Mangalore Refinery & Petrochemicals Limited (A subsidiary of Oil & Natural Gas Corpn. Ltd – ONGC) Kuthethoor P.O., Via: Katipalla, Mangaluru – 575 030.

**BIDDER'S ARE ADVISED NOT TO TAKE ANY
DEVIATION.**

**BID SUBMITTED WITH ANY DEVIATION TO TENDER
DOCUMENT WILL BE LIABLE FOR REJECTION**

**ALL FORMS INDICATED IN BELOW CHECKLIST HAVE TO BE
FILLED UP**

**BIDDERS TO NOTE THAT THERE WILL BE NO TQ/ CQ
AGAINST THIS ENQUIRY. HENCE, BIDDERS ARE ADVISED
TO ADHERE TO TENDER DOCUMENT STRICTLY**

Tender document has been issued to enlisted capable bidders of MRPL. New bidders who desire to participate in the tender and meeting the following pre-qualification criteria, shall send their request through E-mail to the contact person as indicated in Sl. No. 21 (B) of table above for issuing the tender enquiry / including the vendors name in tender. Bidder shall be allowed to participate till the bid closing time.



**PROCUREMENT OF VALVES FOR CONFIDENTIAL DEMO PLANT AT
MRPL, MANGALURU, KARNATAKA**

1.0 Brief Scope of Supply:

SR NO	SHORT DESCRIPTION	LONG DESCRIPTION	MATERIAL	SIZE(Inch)	QTY in Nos.
Group-1					
1	CHECK VALVE	CHECK VALVE, FLANGED, CL 300 LB, RF/125 AARH, BS 1868, ASME B16.5	Body A 216 GR.WCB, Trim-13% CR Steel	2	5
2	CHECK VALVE	CHECK VALVE, FLANGED, CL 150 LB, RF/125 AARH, BS 1868, ASME B16.5	Body A216 GR.WCB, Trim 13% Crome Steel	2	8
3	GATE VALVE	GATE VALVE, FLANGED, CL 150 LB, RF/125 AARH, API 600/ISO 10434, ASME B16.5	Body A 216 GR.WCB, Trim-13%Crome Steel	2	22
4	GATE VALVE	GATE VALVE, FLANGED, CL 300 LB, RF/125 AARH, API 600/ISO 10434, ASME B16.5	Body A 216 GR.WCB, Trim-13% CR Steel	2	9
5	GATE VALVE	GATE VALVE, SCRF, CL 800, API 602/ISO 15761, ASME B 16.11	Body-A 105, 13% crome Steel	0.75	2
6	GATE VALVE	GATE VALVE, SW, CL 800, API 602/ISO 15761, ASME B 16.11	Body-A 105, Trim-Stellited, Stem-13%Crome	0.75	21
Group-2					
1	BUTTERFLY VALVE	BUTTERFLY VALVE, FLANGED, CL 150 , WAF/125 AAR, BS EN 593, ASME B16.5	Body A 216 GR.WCB, Trim 13% Crome Steel	4	2

2.0 Pre-Qualification Criteria (PQC):

Bidder shall be enlisted to MRPL/EIL, Bidder has to provide documentary proof of enlistment or past order details along with bid.

3.0 Bid Evaluation Criteria

1. Adherence to scope of supply, Bidder can quote for both group-1 and group-2 or only group-1/ group-2. Whichever material group bidder is quoting for, shall quote for all items in that group.
2. Bidder shall agree to supply of material as per delivery schedule.
3. Techno-commercially acceptable bid shall be evaluated on overall L1 basis separately for group-1 and Group-2.

4.0 Rejection Criteria:

1. Non enlistment with MRPL/EIL
2. Non adherence to technical or commercial terms, incomplete bid are liable for rejection.



**PROCUREMENT OF VALVES FOR CONFIDENTIAL DEMO PLANT AT
MRPL, MANGALURU, KARNATAKA**

CHECKLIST – PROCUREMENT OF VALVES FOR CONFIDENTIAL DEMO PLANT AT MRPL, MANGALURU, KARNATAKA) (Bidders are advised to fill up each row categorically confirming that he has submitted all the documents as listed below)

Sr. No.	Forms to be submitted	Submission Status (YES/NO)
1	Offer Covering Letter for Bidders (On letterhead)	
2	Tender Doc sealed and signed along with Technical Volume	
3	Amendments Sealed & Signed (Addendums & Corrigendum's)	
4	Power of Attorney (Soft copy and Original Hard copy to be submitted)	
5	Balance Sheets (Last 3 years)	
6	Un-priced bid (To be submitted as per Tender Document mentioning Quoted/ Not Quoted against each item) Page 175-179 of tender documents	
7	GSTN Details with Certificate	
8	Pan Card Copy	
9	GST%	
10	GST (Freight) %	
11	HSN Code	
12	MSE Status	
13	MSE: Certificate	
14	PP-LC Declaration Undertaking. Page No. 99-100 of tender whichever is applicable.	
15	Policy opted for (MSE/PP-LC)	



**PROCUREMENT OF VALVES FOR CONFIDENTIAL DEMO PLANT AT
MRPL, MANGALURU, KARNATAKA**

16	Postal Address:	
17	Dispatch Point:	
18	Agreed Terms & Conditions (to be signed and stamped on each page)	
19	Annexure - I to ATC (duly pre-filled) (to be signed and stamped on each page)	
20	ANNEXURE - A to ITB (Exceptions and Deviations statement Format)	
21	ANNEXURE - B to ITB (Vendor Form)(Bank verification required)	
22	Vendor Code (given by MRPL)	
23	ANNEXURE - C to ITB Integrity Pact along with Affidavit	Not Applicable
24	ANNEXURE - D to ITB (Annual Turn- Over Details)	
25	ANNEXURE - E to ITB (Proforma for Acknowledgement letter of Tender Document) (on letterhead)	
26	ANNEXURE - F to ITB (Form No. 10F, TRC and Permanent Establishment) (on letterhead)	
27	ANNEXURE - G to ITB (Compliance to Requirement to Tender Document) (on letterhead)	
28	ANNEXURE - H to ITB (Declaration of Blacklisting any Govt. Department/ PSU)(on letterhead)	
29	ANNEXURE - I to ITB (Declaration for Liquidation/ Court Receivership)	



PROCUREMENT OF VALVES FOR CONFIDENTIAL DEMO PLANT AT
MRPL, MANGALURU, KARNATAKA

	(on letterhead)	
30	ANNEXURE - J to ITB (Format of Bid Security Declaration from Bidders in Lieu of EMD) (on letterhead)	Not Applicable
31	ANNEXURE - K to ITB (Corporate Guarantee)	
32	Terms and Conditions for Bidders from a Country Sharing Land Borders with India 1. Form A - Bidder's Undertaking2. Form B - Bidder's Undertaking in case of Works Contract. Form C - Bidder's Undertaking (for Transitional Cases)(on letterhead)	
33	Contact detail of the bidder	
34	ESI Certificate	
35	PF Certificate	
36	Article of Association	
37	Memorandum of Article	
38	Security Deposit (5% of order value) / Contract Performance Bank Guarantee (CPBG) is Applicable. Bidder to confirm.	Not Applicable

- a) All the documents submitted by bidder must be signed and stamped.
b) Bidder not allowed to make any changes in the forms/ any other documents.



**PROCUREMENT OF VALVES FOR CONFIDENTIAL DEMO PLANT AT
MRPL, MANGALURU, KARNATAKA**

TENDER No: 3200000897

**PROCUREMENT OF VALVES FOR CONFIDENTIAL
DEMO PLANT AT MRPL, MANGALURU, KARNATAKA**

SECTION- 2

AGREED TERMS & CONDITIONS (ATC) (INDIGENOUS)



**PROCUREMENT OF VALVES FOR CONFIDENTIAL DEMO PLANT AT
MRPL, MANGALURU, KARNATAKA**

**Offer Covering Letter for Bidders
(To be submitted on Letterhead without any modification)**

Date:.....

To

Attn:

Our Ref : dated

Tender No. : 3200000897 dated

Item: For PROCUREMENT OF VALVES FOR CONFIDENTIAL DEMO PLANT AT MRPL, MANGALURU,
KARNATAKA

Sir,

Please find herewith our offer in line with your Tender requirement. We confirm as under:

1. The Delivery/completion period is strictly as per the requirement of Tender document.
2. Offer is in complete compliance with technical specifications / technical documents enclosed with Tender specifications as well as commercial requirements of Tender.
3. The enclosed pre-filled AGREED TERMS & CONDITIONS QUESTIONNAIRE (ATC) shall apply to the offer.
4. The Validity of the offer shall be as per the requirement of Tender document.
5. We have enclosed following with the offer:

a. UNPRICED OFFER:

- (i) Price Schedule Format (WITH PRICES BLANKED)
- (ii) Pre-filled Agreed Terms & Conditions (ATC) along with Annexure -I duly filled in, duly signed and stamped.
- (iii) All documents in support of meeting the requirement of Tender shall be submitted in a separate section/booklet (as applicable).
- (iv) Proforma of Declaration of Black Listing/Holiday Listing - Duly Signed & Stamped
- (v) Vendor Form for Electronic Fund Transfer Payment & Tax details (Ver.9) – duly filled in, signed & stamped by bidder & their bankers
- (vi) Compliance to Requirement to Tender Document (Annexure - G) of ITB.

b. PRICED OFFER:

- (i) Price Schedule Format, duly filled in, signed and stamped

Bidder's Name: _____

Signature: _____

Seal: _____



**PROCUREMENT OF VALVES FOR CONFIDENTIAL DEMO PLANT AT
MRPL, MANGALURU, KARNATAKA**

**MANGALORE REFINERY AND PETROCHEMICALS LIMITED (MRPL)
MANGALORE REFINERY, KARNATAKA, INDIA
AGREED TERMS & CONDITIONS (FOR INDIGENOUS BIDDERS)**

BIDDER's NAME: M/s. _____

TENDER

No.: _____ Dated _____

Bidder's Offer Ref. No. _____

Tel No. : _____ Fax No.: _____

Contact Person : _____ E-Mail: _____ Mobile No: _____

1. DULY SIGNED & STAMPED COPIES OF THIS PRE-FILLED "QUESTIONNAIRE" SHALL BE ENCLOSED WITH UNPRICED BID.
2. FAILURE ON THE PART OF BIDDER IN NOT RETURNING THIS DULY FILLED-UP & SIGNED "QUESTIONNAIRE WITH THEIR UNPRICED BID AND/OR SUBMITTING INCOMPLETE REPLIES MAY LEAD TO REJECTION OF BIDDER'S BID".
3. ALL THE COMMERCIAL TERMS AND CONDITIONS SHALL BE INDICATED BY VENDOR IN THIS FORMAT ONLY AND NOWHERE ELSE IN HIS BID. HOWEVER, IN CASE THE SPACE FOR VENDOR'S REPLY IS NOT SUFFICIENT AGAINST A PARTICULAR QUESTION, THE VENDOR SHALL FURNISH SAME BY WAY OF SEPARATE ANNEXURE ATTACHED TO THIS QUESTIONNAIRE, INDICATING CROSS-REFERENCE OF RESPECTIVE CLAUSES.

S. No.	DESCRIPTION	BIDDER'S CONFIRMATION
1. a	Quoted prices are as per Price Schedule Format enclosed inclusive of Packing & Forwarding charges.	CONFIRMED
1. b	Specify Despatch Point.	
1. c	Quote firm freight charges payable extra (as specified in price schedule). The freight charges shall be exclusive of GST. In case a bidder does not mention anything about the freight component, the same shall be considered as "Nil" and no further confirmation from vendor shall be sought. Evaluation and ordering shall be done considering freight charges as Nil. In case a bidder during techno-commercial evaluation confirms that they have quoted the freight charges or any other charges (forming the part of evaluation) in the priced bid, however after priced bid opening, it is found that these charges are not quoted in priced bid, then such charges shall be deemed to be included in the quoted prices. Evaluation & Ordering shall be carried out including these charges in quoted prices. Indigenous SUPPLIERS are required to dispatch the goods on door delivery basis through any of the IBA approved Transporters.	QUOTED IN PRICE SCHEDULE CONFIRMED CONFIRMED CONFIRMED



**PROCUREMENT OF VALVES FOR CONFIDENTIAL DEMO PLANT AT
MRPL, MANGALURU, KARNATAKA**

S. No.	DESCRIPTION	BIDDER'S CONFIRMATION
1. d	Transit risk insurance shall be covered by the Owner against their MCE (Marine cum Erection) Policy and the same shall not be included in the quoted prices.	CONFIRMED
2.a	GST applicable extra: 1) HSN No. 2) Present rate of GST payable extra on products (including spares).	1)..... 2) QUOTED IN ANNEXURE I
2.d	The GST shall be released against receipt of tax invoice. In case of non-receipt of tax invoice or non payment of GST by the contractor/vendor, MRPL shall withhold the payment of GST. Confirm acceptance.	CONFIRMED
2.e 1)	Only statutory variations, if any, in the present rate of GST, shall be reimbursed as under: i. Any increase in the rates of GST within the CDD [contractual delivery date or approved extended date] shall be borne by MRPL. ii. Any increase in the rates of GST beyond the CDD [contractual delivery date or approved extended date] will be borne by MRPL to the extent <i>Input Tax Credit</i> documents are passed on to MRPL and MRPL is in a position to get the <i>Input Tax Credit</i> from the GST authorities. The benefit of any reduction beyond CDD must be passed on to MRPL. iii. Any variation in GST at the time of supplies for any reasons, other than statutory, including variations due to turnover, shall be borne by bidder. iv. Material supplied will be eligible for <i>Input Tax Credit</i> and Bidder shall furnish all documents as required to avail the same. v. In case GST is not applicable at present but becomes applicable at the time of contractual delivery period due to any reasons other than statutory, the same shall be borne by bidder. Confirm acceptance.	CONFIRMED CONFIRMED CONFIRMED CONFIRMED
3.a	Any increase in the existing taxes / duties or any new or additional taxes or duties imposed after contractual delivery shall be to BIDDER'S account whereas any corresponding decrease shall be passed on to the Owner.	NOTED



**PROCUREMENT OF VALVES FOR CONFIDENTIAL DEMO PLANT AT
MRPL, MANGALURU, KARNATAKA**

S. no.	DESCRIPTION	BIDDER'S CONFIRMATION
<p>4.a</p> <p>4.b</p>	<p>SUPERVISION / TRAINING CHARGES</p> <p>For Supervision / Training Charges, if in the scope of the Bidder as per Tender, please confirm the following:</p> <ol style="list-style-type: none"> 1) Confirm that per diem rate for site supervision services / Training is inclusive of all taxes and duties except GST (if in the scope of Bidder as per Tender.) 2) Percentage of GST as applicable extra on Supervision / Training Charges. 3) Per-diem rate for supervision has been quoted in accordance with the Terms and Conditions for Supervision enclosed with the Tender Documents <p>SITE WORK</p> <p>For Site Work, if in the scope of the Bidder as per Tender, please confirm the following:</p> <ol style="list-style-type: none"> 1) Confirm that quoted site work prices are exclusive of GST 2) Confirm that apart from S.No. 4.b 1) above, quoted site work prices are inclusive of all other applicable taxes & duties and nothing extra shall be payable by OWNER. 3) Percentage of GST as applicable extra on Site Work. <ol style="list-style-type: none"> 1) Any increase in the rates of GST within the CDD [contractual delivery date or approved extended date] shall be borne by MRPL. 2) Any increase in the rates of GST beyond the CDD [contractual delivery date or approved extended date] will be borne by MRPL. The benefit of any reduction beyond CDD must be passed on to MRPL. Seller shall provide all the documents for MRPL to input tax credit. In case, MRPL is not able to claim Input Tax credit based on the invoices/documents submitted by the seller, GST amount to that extent shall not be payable by MRPL. 	<p>CONFIRMED</p> <p>4.a 2): Quoted in Annexure I</p> <p>CONFIRMED</p> <p>CONFIRMED</p> <p>CONFIRMED</p> <p>CONFIRMED</p> <p>Quoted in Annexure I</p> <p>NOTED</p> <p>NOTED</p>
<p>5.</p>	<p>Price Reduction Schedule / Delayed Delivery</p> <ol style="list-style-type: none"> 1) Confirm Acceptance to Clause 18.1 (a) of SPC for "Bulk items". <p>Confirm Acceptance to Clause 18.1 (b) of SPC "for items other than bulk items (with or without site work).</p>	<p>Not Applicable</p> <p>CONFIRMED</p>



**PROCUREMENT OF VALVES FOR CONFIDENTIAL DEMO PLANT AT
MRPL, MANGALURU, KARNATAKA**

Sr. No.	DESCRIPTION	BIDDER'S CONFIRMATION
	2) The Bidder shall submit credit note / adjustment in GST Invoice for PRS, if applicable, on account of delay in delivery. This is with respect to cases wherein Bidder has not considered the applicable PRS in GST Invoice.	CONFIRMED
6.	Delivery Period:	
6.a	Confirm acceptance to delivery period as stipulated in the Tender.	CONFIRMED
6.b	Delivery period will be reckoned from the date of MRPL's Purchase Order (PO).	CONFIRMED
7.	Payment Terms: Confirm acceptance to following:	
7.a	Acceptance of applicable Payment terms as mentioned in the Tender	CONFIRMED
7.b	Advance payment is not acceptable. However, progressive payment as specified in the Commercial Terms enclosed on achievement of specific milestones (under applicable payment terms) shall be against equivalent Advance Bank Guarantee as per MRPL format for all payments before despatch.	CONFIRMED
7.c	In case of delay in delivery, bills shall be submitted after deducting price reduction for delay.	CONFIRMED
8.a.	Part Order:	
	a) Acceptance of Part Order as per GPC Clause No. 32 and clause 23.0 of SPC.	Not Applicable
	b) Any charges quoted extra as lumpsum (like IBR, Testing, freight, etc.) shall be applicable prorata on value basis in the event of part order / part quantities / split order.	Not Applicable
8.b	MSE (MICRO & SMALL ENTERPRISE) BIDDERS:	
	a) Confirm whether the bidder is a MSE bidder or not.	Yes / No (tick ✓ whichever is applicable)
	b) Confirm owner of bidder's organisation belongs to Gen/SC/ST Category.	Gen / SC / ST
	c) In case owner of bidder's organisation belongs to SC/ST, then bidder to submit SC/ST Certificate issued by District Authority duly certified by Statutory Auditor Or Notorised	Applicable and enclosed / Not applicable
	d) In case owner of bidder's organization is a woman entrepreneur, then bidder to submit Bank Account Details/Partnership deed/Certificate of Incorporation along-with MoA/AoA duly certified by Statutory Auditor or Notorised.	Applicable and enclosed /Not applicable



**PROCUREMENT OF VALVES FOR CONFIDENTIAL DEMO PLANT AT
MRPL, MANGALURU, KARNATAKA**

9.	Repeat Order: Confirm acceptance of repeat order within Six months from the date of MRPL's PO, on the same unit price and terms & conditions in line with clause 22.0 of SPC.	Applicable
10	Contract Cum Performance Bank Guarantee (CPBG): Confirm acceptance for submission of CPBG as per clause 17.0 of SPC.	Not Applicable
11.	Firmness of prices: Quoted prices shall remain Firm and Fixed till complete Execution of the order.	CONFIRMED
12. 12.a	Testing and Inspection charges: Goods and services shall be subject to stage wise and final inspection by any of the Third Party Inspection (TPI) agencies (listed in the Special Purchase Conditions), and TPI charges are included in quoted prices, and TPI shall be arranged by Bidder.	CONFIRMED
12.b	In case of items where Inspection is to carried out by Consultant as per Tender, the same shall not be included in the quoted price.	CONFIRMED
12.c	Similarly, all built in import content (if applicable) shall also be subject to inspection by TPI agencies listed in the Special Purchase Conditions, in the country of origin of the import content, and charges for the same are included in quoted prices, and no additional charges shall be paid by Owner.	CONFIRMED
12.d	Quoted prices are: i. Inclusive of charges for all facilities required for testing and all inspection requirements specified in the technical specifications and documents enclosed with the Tender. ii. Inclusive of all IBR/IGC/NACE/Radiography charges as per Consultant's technical specifications and the documents enclosed with the Tender.	CONFIRMED CONFIRMED (if applicable)



**PROCUREMENT OF VALVES FOR CONFIDENTIAL DEMO PLANT AT
MRPL, MANGALURU, KARNATAKA**

Sr. No.	DESCRIPTION	BIDDER'S CONFIRMATION
13.	<p>Import Content:</p> <p>a) Supplies by Indian suppliers containing built-in import content.</p> <ul style="list-style-type: none"> i. Quoted prices are inclusive of Basic Customs Duty and custom cess after considering the benefit of Input Tax Credit on IGST portion. ii. Supplier shall be responsible for the timely payment of the customs duties to the relevant Government Authorities. iii. All harbour dues, pilotage fees, port fees, wharf fees, unloading costs incurred in India in respect of any imported goods shall be to supplier's account. iv. Prices shall be firm on account of variation in foreign exchange rate. v. Prices for such import content shall also include any additional levies/duties on Imports (viz. Anti- Dumping Duty, Safeguard Duty, etc.) as notified by Govt of India from time to time, as applicable. vi. Owner shall not provide any import licence. vii. Any upward variation due to change in Customs Duty classifications shall be absorbed by the Bidder. However, any reduction in customs duty due to change in classification shall be passed on to Owner. viii. Prices shall be firm on account of any variation in Custom Duties. <p>b) Supplies of Imported finished goods directly supplied to site by Indian Supplier</p> <ul style="list-style-type: none"> i. GST on imported capital goods sold & supplied to MRPL and consigned to MRPL against which Input Tax Credit shall be available to MRPL shall not be included in the quoted prices and shall not be considered for evaluation. Quoted prices shall be inclusive of Basic Customs Duty & Custom cess only. ii. The Seller shall provide MRPL with all documents necessary for MRPL to claim Input Tax Credit on the GST paid on the imported materials covered by the Supplies, including but not limited to CENVAT Bill of Entry 	<p>a. Applicable / Not Applicable (tick ✓ whichever is applicable)</p> <p>(i) CONFIRMED</p> <p>(ii) CONFIRMED</p> <p>(iii) CONFIRMED</p> <p>(iv) CONFIRMED</p> <p>(v) CONFIRMED</p> <p>vi) CONFIRMED</p> <p>(vii) CONFIRMED</p> <p>(viii) Noted</p> <p>b. Applicable / Not Applicable (tick ✓ whichever is applicable)</p> <p>(i) CONFIRMED</p> <p>(ii) CONFIRMED</p>
14.	<p>Validity: Validity of the offer shall be as per NIT of Tender.</p>	<p align="center">CONFIRMED</p>



**PROCUREMENT OF VALVES FOR CONFIDENTIAL DEMO PLANT AT
MRPL, MANGALURU, KARNATAKA**

15.	<p>Confirm Acceptance of all other terms & conditions as per attached:</p> <p>a) Notice Inviting Tender (NIT) b) General Purchase Conditions (GPC). c) Instructions to Bidder (ITB) d) Special Purchase Conditions (SPC). e) Terms & Conditions for supervision of Erection, Testing & Commissioning for Indigenous Bidders, f) Terms & Conditions for Site Work /HSE requirement as per Tender. g) Terms & Conditions for Annual Maintenance Contract (AMC) h) Terms & Conditions for Training</p>	<p align="center">CONFIRMED</p> <p>Not Applicable (e,f,g and h)</p>
16.	<p>Whether any of the Directors of BIDDER is a relative of any Director of Owner or the BIDDER is a firm in which any Director of Owner or his relative is a Partner or the BIDDER is a private company in which any director of Owner is a member or Director.</p>	<p align="center">Yes / No (tick ✓ whichever is applicable)</p>
17.a	<p>Please confirm you have not been banned or delisted by any Government or Quasi Government agencies or PSUs. If you have been banned, then this fact must be clearly stated. This does not necessarily become a cause for disqualification. However if this declaration is not furnished the bid shall be rejected as non-responsive.</p>	<p align="center">CONFIRMED</p>
17.b	<p>Please confirm that you have filled in, signed and attached the enclosed "Proforma of Declaration of Black Listing / Holiday Listing" along with your unpriced offer.</p>	<p align="center">CONFIRMED</p>
18	<p>Spares Parts:</p> <p>a) Confirm that your quoted prices are inclusive of all mandatory spares and all commissioning spares as stipulated in Consultant's technical specifications.</p> <p>b) Confirm that item wise unit price of Recommended spare parts for two years as stipulated in technical specifications have been quoted separately indicating Dispatch quantity.</p> <p>c) Special Tools and Tackles as specified in the Tender are included in the quoted prices.</p>	<p align="center">CONFIRMED</p> <p align="center">CONFIRMED</p> <p align="center">CONFIRMED</p>
19.	<p>Bidder to confirm that all authenticated documents submitted for meeting the PQC are certified as per the authentication requirement defined in the Tender document. (Applicable for NIT/IFB cases only).</p>	<p align="center">Applicable</p>
20.	<p>Deviations to Terms & Conditions shall lead to loading of prices as per Commercial Terms enclosed with this Tender or rejection of offer. Please confirm acceptance.</p>	<p align="center">CONFIRMED</p>



**PROCUREMENT OF VALVES FOR CONFIDENTIAL DEMO PLANT AT
MRPL, MANGALURU, KARNATAKA**

21.	Bidder to indicate the complete name and address on which order to be placed by MRPL (in the event of an order)	_____ _____ _____
22.	Printed terms and conditions, if any, appearing in quotation, shall not be applicable in the event of order. In case of contradiction between the confirmations given above and terms & conditions mentioned elsewhere in the offer, the confirmation given above in this ATC shall prevail.	CONFIRMED
23.	Bidder to confirm that he has submitted all the requisite forms from A TO K as per Annexure 1 attached This document has to be submitted along with Unpriced bid	CONFIRMED

BIDDER'S SIGNATURE & DATE: _____

SEAL/ STAMP



**PROCUREMENT OF VALVES FOR CONFIDENTIAL DEMO PLANT AT
MRPL, MANGALURU, KARNATAKA**

ANNEXURE-I to ATC (FOR INDIGENOUS BIDDERS)

**MANGALORE REFINERY AND PETROCHEMICALS LIMITED (MRPL)
MANGALORE REFINERY, KARNATAKA, INDIA**

Taxes and Duties format for Indian Bidders

NAME OF BIDDER: _____

OFFER REF. _____ **Dated** _____

TENDER NO.: _____

The salient features of the offer are as below:

1. SPECIFY DESPATCH POINT	_____
2. GSTIN NO. OF DESPATCH POINT	_____
3. SPECIFY INVOICING PLACE	_____
4. GSTIN NO. OF INVOICING PLACE	_____
5. PACKING & FORWARDING CHARGES	INCLUDED IN THE QUOTED
6. HSN CODE OF GOODS	
7. GST APPLICABLE ON QUOTED FOT DESPATCH POINT PRICES CGST plus SGST () / IGST () (√) whichever is applicable	1) _____ % EXTRA
8. INLAND FRIEGHT CHARGES EXTRA UPTO PROJECT SITE EXCLUSIVE OF GST	QUOTED IN THE PRICE SCHEDULE.
9. GST RATE APPLICABLE ON FREIGHT	_____ % EXTRA
10. SAC CODE FOR SITE SUPERVISION / SITE WORK / TRAINING CHARGES	_____/_____/_____
11. GST APPLICABLE EXTRA ON QUOTED SITE SUPERVISION / SITE WORK / TRAINING CHARGES	_____/_____/_____ % EXTRA
12. CONFIRM WHETHER BIDDER HAS QUOTED UNDER COMPOSITION SCHEME. IF YES, THAN GST RATE QUOTED ABOVE SHALL BE CONSIDERED FOR EVALUATION WITHOUT INPUT TAX CREDIT (ITC)	<input type="checkbox"/> Yes
	<input type="checkbox"/> No

BIDDER'S SIGNATURE & DATE: _____

SEAL/STAMP:



**PROCUREMENT OF VALVES FOR CONFIDENTIAL DEMO PLANT AT
MRPL, MANGALURU, KARNATAKA**

TENDER No: 3200000897

**PROCUREMENT OF VALVES FOR CONFIDENTIAL
DEMO PLANT AT MRPL, MANGALURU, KARNATAKA**

SECTION-3

INSTRUCTIONS TO BIDDER (ITB)



**PROCUREMENT OF VALVES FOR CONFIDENTIAL DEMO PLANT AT
MRPL, MANGALURU, KARNATAKA**

Contents

- 1.0 TENDER DOCUMENT, CLARIFICATION AND ADDENDUM / AMENDMENT
- 1.1 TENDER DOCUMENT
- 1.2 CLARIFICATION REQUESTS BY BIDDER
- 1.3 AMENDMENT OF TENDER
- 1.4 CONFIDENTIALITY OF TENDER DOCUMENT
- 1.5 ACKNOWLEDGEMENT AND CONFIRMATION TO BID
- 1.6 MULTIPLE/ ALTERNATIVE BID
- 2.0 PREPARATION OF BIDS
- 2.1 BID VALIDITY
- 2.2 COST OF BIDDING
- 2.3 LANGUAGE OF BID
- 2.4 ARRANGEMENT OF BID
- 2.5 SCHEDULE OF PRICES
- 2.6 DOCUMENTS COMPRISING THE BID AND TENDERS INVITED THROUGH E-PROCUREMENT SYSTEM
- 2.7 EARNEST MONEY DEPOSIT (EMD)
- 3.0 SUBMISSION OF BID
- 4.0 BID OPENING AND EVALUATION
- 4.1 OPENING OF TECHNO-COMMERCIAL BIDS
- 4.2 CLARIFICATION & ADDITIONAL INFORMATION
- 4.3 TECHNO-COMMERCIAL DISCUSSIONS
- 4.4 DEVIATIONS
- 4.5 PROCESS TO BE CONFIDENTIAL
- 4.6 OWNER'S RIGHT TO ACCEPT OR REJECT A BID
- 4.7 REJECTION CRITERIA
- 5.0 AWARD OF WORK
- 5.1 AWARD
- 6.0 NOTIFICATION OF AWARD
- 7.0 INTEGRITY PACT ALONG WITH AFFIDAVIT –Not Applicable
- 8.0 CARTEL FORMATION
- 9.0 FRAUDULENT PRACTICES



**PROCUREMENT OF VALVES FOR CONFIDENTIAL DEMO PLANT AT
MRPL, MANGALURU, KARNATAKA**

- 10.0 REQUIREMENT OF EMPLOYEMENT VISA FOR FOREIGN NATIONALS
- 11.0 PRICE BID OPENING
- 12.0 INFORMATION REQUIRED FROM FOREIGN SUPPLIERS / CONTRACTORS FOR ALL CASES OTHER THAN SUPPLY ORDERS
- 13.0 COMPLIANCE TO REQUIREMENT TO TENDER DOCUMENT
- 14.0 BANK GUARANTEE (BG) VERIFICATION UNDER THE “STRUCTURED FINANCIAL MESSAGING SYSTEM” (SFMS)
- **ANNEXURE - A** - EXCEPTIONS AND DEVIATIONS STATEMENT FORMAT
 - **ANNEXURE - B** - VENDOR FORM FOR ELECTRONIC FUNDS TRANSFER PAYMENT & TAX DETAILS
 - **ANNEXURE - C** - INTEGRITY PACT ALONG WITH AFFIDAVIT - NOT APPLICABLE
 - **ANNEXURE - D** - ANNUAL TURNOVER DETAILS
 - **ANNEXURE - E** - PROFORMA FOR ACKNOWLEDGEMENT LETTER OF TENDER
 - **ANNEXURE - F** - FORM NO. 10F, TRC AND PERMANENT ESTABLISHMENT
 - **ANNEXURE - G** - COMPLIANCE TO REQUIREMENT TO TENDER DOCUMENT
 - **ANNEXURE - H** - DECLARATION OF BLACKLISTING BY ANY GOVT DEPARTMENT / PSU
 - **ANNEXURE - I** - DECLARATION FOR LIQUIDATION/ COURT RECEIVERSHIP
 - **ANNEXURE - J** - FORMAT OF BID SECURITY DECLARATION FROM BIDDERS IN LIEU OF EMD
 - **ANNEXURE - K** - CORPORATE GUARANTEE



**PROCUREMENT OF VALVES FOR CONFIDENTIAL DEMO PLANT AT
MRPL, MANGALURU, KARNATAKA**

1.0 TENDER DOCUMENT, CLARIFICATION AND ADDENDUM/AMENDMENT

1.1 TENDER DOCUMENT

1.1.1 TENDER document comprising following sections are uploaded on E- portal through EPS for the purpose of submitting Bid.

- I. Notice Inviting Tender (NIT)
- II. Agreed Terms & Conditions (ATC)
- III. Instructions To Bidder(ITB)
- IV. Special Purchase Conditions (SPC)
- V. General Purchase Conditions(GPC)
- VI. Price Schedule
- VII. Technical Specifications

1.1.2 The complete Tender document through EPS.

1.1.3 Any Amendment/ Addendum issued in accordance with clause no. 1.3 hereinafter shall also form part of the Tender Document.

1.1.4 **All Amendments, time extension, clarifications, etc. will be uploaded through EPS only.**

1.1.5 Request for extension or any queries received from any bidder with less than ten working days prior to bid due date shall generally be ignored, since there will not be adequate time for proper communication with Client and other Bidders. Bidders shall submit the bid directly and in their own name without involving any intermediaries.

1.1.6 "Bidder" shall mean the Agency who has submitted the bid for the supply/ services described in this Tender Document.

1.2 Clarification Requests by Bidder

Bidder shall examine the TENDER thoroughly in all respects and if any conflict, discrepancy, error or omission is observed, Bidder may request clarification during pre-bid meeting (if applicable) and queries shall reach to MRPL on or before the date of receipt of queries indicated in TENDER. Such clarification shall be mailed to the concerned person as mentioned in NIT. Any failure by Bidder to comply with the aforesaid requirement shall not absolve the Bidder of his responsibility, after subsequent award of Contract, of performing in accordance with the agreement. The replies to pre-bid queries are for clarification purpose only and shall not form part of the TENDER Document, unless issued in the form of Addendum / Amendment.

1.3 Amendment of TENDER

1.3.1 Owner may, for any reason either at their own initiative or in response to the clarification requested by prospective Bidders, issue Addendum/ Amendment during the Bidding period or subsequent to receiving the Bids. Any Addendum/ Amendment thus issued shall become part of TENDER document and Bidder shall submit the copy of Addendum/ Amendment duly signed and stamped in token of their acceptance.

1.3.2 **Prior to submission of Bid:** If Addendum/ Amendment is issued during the Bidding period, it will be deemed presumed that Bidder has submitted their Bid



**PROCUREMENT OF VALVES FOR CONFIDENTIAL DEMO PLANT AT
MRPL, MANGALURU, KARNATAKA**

considering such Addendum/ Amendment.

- 1.3.3 **After submission of Bid:** If Addendum/ Amendment is issued subsequent to receiving the Bids, Bidder shall follow the instructions issued along with Addendum/ Amendment with regard to submission of impact on quoted price/ revised price, if any.
- 1.3.4 Bidders to note that price changes against Technical / commercial clarifications, in line with terms & conditions of enquiry documents are not allowed. In case any bidder gives positive revised prices / price implications against such clarifications, their bid shall be rejected.

1.4 Confidentiality of TENDER Document

- 1.4.1 The TENDER are non-transferable and shall be returned to the OWNER by any recipient who does not intend to submit a Bid.
- 1.4.2 The TENDER are and shall remain the exclusive property of the OWNER with the right of the Bidder to use it only for the intended purpose of bidding and for use by the successful Bidder with reference to the resultant Contract for the Owner's subject Unit.
- 1.4.3 The Bidder shall take due measures to keep it secret and confidential and shall disclose the TENDER and/or furnish copies in whole or part thereof to employees involved in the preparation of the Bid who have understood the proprietary and confidential nature of the documents and have undertaken to be bound by and maintain confidentiality.

1.5 Acknowledgement and Confirmation to Bid

Within 7 days of receipt of the TENDER, Bidder shall complete and submit the acknowledgement letter as per Proforma given in **Annexure–E** confirming whether or not the Bidder intends to submit their Bid. The Bidder must indicate the address of their bidding office in the acknowledgement letter along with Contact Mobile no. with ISD codes, Telephone/ Fax with ISD codes, Email and names of contact persons. In case Bidder is not bidding, they should clearly state the reasons for non-submission of their Bid.

1.6 Multiple/ Alternative Bid

- 1.6.1 A bidder (i.e. the bidding entity) shall, on no account submit more than one bid either directly or indirectly failing which following actions shall be initiated:
- 1.6.2 All bids submitted by such bidder (say 'A') directly & indirectly, shall stand rejected.
- 1.6.3 If another bidder (say 'B') has proposed bidder 'A' as a sub-contractor then bidder 'B's bid shall also be rejected. However, in case the bidder 'B' has also proposed an alternative sub-contractor who is other than the bidder 'A', then bidder 'B's bid shall be evaluated with the proposed alternative sub-contractor only. Hence, every bidder shall ensure in his own interest that his proposed sub-contractor is not submitting alternative/ multiple bids."

However, an agency can be a subcontractor or back up with more than one bidder provided the agency is not participating directly in the bidding process as a bidder.

- 1.6.4 Alternative bids are not acceptable

2.0 PREPARATION OF BIDS



**PROCUREMENT OF VALVES FOR CONFIDENTIAL DEMO PLANT AT
MRPL, MANGALURU, KARNATAKA**

2.1 Bid Validity

Bid shall remain valid for acceptance for a period as mentioned in the NIT from the due date/ extended due date of submission of the Bid. During the said period, the Bidder shall not revoke or cancel his Bid or vary the Bid except and to the extent required by Owner in writing. Bid shall be revalidated for extended period if required by Owner in writing. In such cases, unless otherwise specified, it shall be understood that validity is sought and provided without varying either the quoted price or any other terms and conditions of the Bid finalised till that time.

2.2 Cost of Bidding

All direct and indirect costs associated with the preparation and submission of Bid, any other expenses in connection with Bid (including clarification meetings and visits by Bidder to Owner offices, if any) shall be to Bidder's account. Owner will in no case be responsible or liable for those costs, regardless of the conduct or outcome of the Bidding process.

2.3 Language of Bid

The Bid and all correspondence incidental to and concerning the Bid shall be in the English Language only. In case of foreign Bidder, if the above supporting documents including bound published annual report are not in English Language, then the English translation copy of the same, shall also be furnished duly certified, stamped and signed by local Chamber of Commerce and authentication of the English Translation shall be done as per provisions of TENDER. Translation from agencies approved by relevant embassy / high commission or other accredited agencies shall also be acceptable. For the purpose of interpretation / evaluation of Bid, the English Translation shall govern.

2.4 Arrangement of Bid

The Bid shall be neatly arranged, and printed on white paper with consecutively numbered pages. The Bid and all details submitted by the Bidder subsequently shall be signed and stamped on each page by a person, legally authorised to enter into Agreement on behalf of the Bidder. The same person shall also sign corrections and alterations, if any. Bidder shall submit Power of Attorney (POA) in favour of the person who signs the Bid and subsequent submissions on behalf of the Bidder.

Bidder shall clearly indicate their legal constitution and the person signing the Bid shall state his capacity as also the source of his ability to bind the Bidder. The Power of Attorney or Authorization or other document constituting adequate proof of the ability of the signatory to bind the Bidder, shall be annexed to the Bid. Owner may reject outright any Bid unsupported by adequate proof of the signatory's authority.

2.5 Schedule of Prices

2.5.1 The Schedule of Prices shall be read in conjunction with all other sections of the TENDER Document. Rates/ amount must be filled in the format of Schedule of Prices enclosed as part of this TENDER Document.

2.5.2 The Prices quoted by the Bidder shall be **FIRM** and fixed for the completion period of the offered services and supplies and in accordance with the price schedule format included in the TENDER and strictly based on the terms specified related to the bid prices in the instructions/conditions.



**PROCUREMENT OF VALVES FOR CONFIDENTIAL DEMO PLANT AT
MRPL, MANGALURU, KARNATAKA**

2.5.3 **FIRM** prices are required for all the items including services.

2.5.4 Bidder shall quote all the items of Schedule of Prices after careful analysis of cost involved for the performance of the completed item considering all parts of the TENDER Document. In case any activity is specifically not covered in description of item under Schedule of Prices but is required to complete the work as specified elsewhere in the TENDER Document, then the quoted prices for the item(s) shall be deemed to be inclusive of cost incurred for such activity and no claims whatsoever on this account shall be entertained by Owner.

2.5.5 The foreign component of the Bidder's prices shall be quoted either in US Dollars/ Euro and the Indian component in Indian Rupees only. For services and materials to be procured from India, Bidder shall quote prices in Indian Rupees only.

Currency once quoted shall not be permitted to be changed. Bidder shall quote prices both in figures as well as in words.

2.6 Documents Comprising the Bid and TENDERS Invited through E-Procurement System:

2.6.1 The offer must be complete in all respects, leaving no scope for ambiguity, Bidder is fully responsible for the bid submitted and no relief or consideration can be given for errors and omissions. Bids shall be submitted through online (EPS) mode only. Bid must be submitted by the due date and time mentioned in the Notice Inviting Tender (NIT) or any extension thereon e-tender website. Bidder shall submit the offer in two parts:

Part-I Technical & Commercial (un-priced) bid and
Part –II Priced bid.

2.6.2 Price bid & technical bids if submitted together shall be summarily rejected.

2.6.2.1 Part-I : Techno-Commercial Bid (UNPRICED BID) :

Bidder shall submit the following documents duly filled in, signed and stamped by authorised person.

1. Submission of Bid letter/ covering letter along with Validity of Bid as per clause no. **2.1** above.
2. Documents, duly authenticated, as per the requirement of TENDER in a separate Section/Booklet titled as "TENDER Document"
3. Master Index along with Amendments (if any), duly signed and stamped on each page, in token of acceptance of TENDER document and Amendments.
4. Power of Attorney in favour of authorised signatory of the Bid.
5. Compliance to Bid requirements as per **Annexure-G to ITB** and Exception and Deviation Statement as per **Annexure-A to ITB**.
6. ATC along with Annexure – I, duly pre-filled in as per **Section 2 of Volume - I to Commercial Section**.
7. Vendor Form for Electronic Funds Transfer Payment & Tax Details as per **Annexure-B to ITB**.



**PROCUREMENT OF VALVES FOR CONFIDENTIAL DEMO PLANT AT
MRPL, MANGALURU, KARNATAKA**

8. ~~Integrity Pact (included as Annexure-C) duly signed by the Bidder along with affidavit.~~
9. Annual Turnover details duly filled in as per **Annexure-D to ITB.**
10. FORM NO. 10F, TRC and Permanent Establishment as per **Annexure-F to ITB.**
11. Blacklisting/ Holiday as per **Annexure-H to ITB.**
12. Declaration for Liquidation/ Court Receivership as per **Annexure-I to ITB.**
13. Proforma for Acknowledgement Letter of TENDER Document as per **Annexure-E to ITB.**
14. Duly Signed & Stamped copy of Terms & Conditions Supervision of Erection, Testing & Commissioning (If Applicable) (**Annexure A to SPC**)
15. Duly Signed & Stamped copy of Terms & Conditions For Post Warranty Comprehensive Annual Maintenance Contract (If Applicable) (**Annexure B to SPC**)
16. Terms & Conditions for Training of Employer's Personnel At Manufacturer's Works/ Facilities (If Applicable As Per Technical Specification) (**Annexure C to SPC**)
17. Terms & Conditions for Site Work (If Applicable) (**Annexure D to SPC**)

Note: Bidder is required to submit hard copy (in Original of the following documents for e-TENDERS:

- a. **Earnest Money Deposit, if applicable**
- b. **Power of Attorney**

The hardcopy of these documents shall reach to the Consultants office before the end of due date:

2.6.2.2 Part-II – Price Part

Price part shall contains Price Schedule, duly filled in and shall consist of the following.

SECTION – 6 Price Schedule

No stipulation, deviation, terms or conditions, presumptions, basis etc. shall be indicated in Price part of the Bid. In case, any stipulation, deviation, terms or conditions, presumptions, basis etc. are indicated in the Priced Bid, these shall be considered null and void and may render the Bid liable for rejection if these are not withdrawn by the Bidder.

2.6.2.3 CORRECTIONS AND ERASURES

Bidders are required to fill in the TENDER Documents with all due care, avoiding cuttings/corrections/alteration/overwriting etc. in the entries, as far as possible. In case corrections/alterations become unavoidable or inevitable, the entry to be corrected, altered should be neatly cancelled or scored through by striking the entry by drawing a line through it and making the revised/corrected entry as close to the cancelled entry as possible, each such cancellation and correction/alteration being clearly and unambiguously authenticated by the Bidder by his full signatures. Overwriting and/or erasing with or by the application of correcting/erasing fluid(s) will



**PROCUREMENT OF VALVES FOR CONFIDENTIAL DEMO PLANT AT
MRPL, MANGALURU, KARNATAKA**

not be permitted and shall render the TENDER for rejection.

2.7 EARNEST MONEY DEPOSIT (EMD): - Not Applicable

- 2.7.1 EMD shall be submitted by way of Online payment through internet banking (MRPL Bank details are attached in tender GCC section) or Demand Draft in favour of M/s Mangalore Refinery and Petrochemicals Limited, and payable at Mangalore. Bank Guarantee in place of demand draft shall also be accepted as per format enclosed. **BG shall be valid for 180 days from the date of bid submission. Offer submitted without requisite / insufficient EMD will be summarily rejected without assigning any reason.**

The irrevocable Bank Guarantee (BG) in the prescribed format if submitted against Earnest Money Deposit shall be subject to verification from the issuing Bank, the email ID of bank for the same must be incorporated in the BG.

The BG issued by the issuing Bank on behalf of Bidder/Contractor/Supplier in favour of "Mangalore Refinery and Petrochemicals Limited" shall be in paper form and also be made available under the "Structured Financial Messaging System" (SFMS).

A separate advice of the BG will invariably be sent by the issuing bank to the beneficiary's' Bank through SFMS and SFMS transmission message reference number (currently 32digits code) is to be sent along with BG directly to MRPL through speed post/regd. Post.

The details of beneficiary for issue of BG under SFMS platform is furnished below: **(SFMS Procedure and MRPL Bank details are attached with tender under Exhibit 10)**

Name of Beneficiary: Mangalore Refinery and Petrochemicals Limited

Beneficiary Bank, Branch and address: Union Bank of India (Erstwhile Corporation Bank), MRPL Project Site, Kuthethoor Post Mangalore 575030, Karnataka

Bank Account No: 560101000026927

IFSC code: UBIN0905925

SWIFT Code: UBININBBMAP

MICR Code: 575026018

Any bank guarantee submitted in physical mode which cannot be verifiable through SFMS will not be accepted under any circumstances

- 2.7.2 Earnest Money Deposit (EMD) of value mentioned above should be sent in a separate cover to the following address;
Projects Department,
Mangalore Refinery & Petrochemicals Limited,
Kuthethoor P.O., Via Katipalla,
Mangaluru- 575 030.

Super scribing tender number and bid submission date on the envelope. It should reach positively on or before the bid due date and time. Otherwise, the bid will be liable for rejection.

- 2.7.3 In case of bids invited through EPS, Bidders are also advised to scan the Draft/BG and upload in EPS along with the technical bid document.
- 2.7.4 Incomplete tender/ tenders **without requisite / insufficient EMD** will be rejected. The Company reserves the right to reject a tender or all the tenders without



**PROCUREMENT OF VALVES FOR CONFIDENTIAL DEMO PLANT AT
MRPL, MANGALURU, KARNATAKA**

assigning any reason whatsoever.

- 2.7.5 EMD may be paid in one of the following forms in a separate sealed cover.
Demand drafts drawn on Scheduled Bank in favour of Mangalore Refinery and Petrochemicals Ltd, Mangalore.
- i. Bank Guarantee in prescribed format (enclosed) which is enclosed, executed by scheduled / Nationalised Bank and valid for a period of 180 days.
 - ii. EMD to be sent to the concerned officer before due date/ time.
- 2.7.0 Company will not be responsible for loss or late / non receipt of EMD. No interest shall be payable on Earnest Money Deposit. Late receipt of EMD will be summarily rejected. No Cheques will be accepted towards EMD.
- 2.7.1 Tender will be summarily rejected under following circumstances
- i. EMD submitted in form of cheque.
 - ii. The name of tender mentioned in the BG is different from the tender for which bids have been invited.
 - iii. The firm on whose behalf the BG has been furnished is different from the bidder
 - iv. The EMD is not of prescribed/requisite value.
 - v. The validity of the BG is less than the stipulated period.
 - vi. Earnest Money is liable to be forfeited if tenderer.
- Withdraws or modifies offer in full or part during the validity period.
 - Failure of the bidder to honor their offer.
 - Non acceptance of Purchase / Work Order placed by MRPL.
 - Does not confirm of acceptance of order within the stipulated time after placement of order.
 - Inability to perform satisfactorily after receipt of order in case of successful bidder.
 - If document(s)/certificate(s) submitted along with the bid are found false/fake, fabricated, incorrect information.
 - The name of the tender mentioned in the BG is different from the tender for which bids have been invited.
 - The firm on whose behalf the BG has been furnished is different from the bidder.
- 2.7.2 The following are exempted from submission of EMD
- I. The unit is registered with NSIC for the item tendered.
 - II. Government Departments/PSU's, Any other body specified by Ministry of MSME(MoMSME), Udyog Aadhaar Memorandum issued by MoMSME, Start-ups are exempted from submission of EMD.
 - III. In- line with the Government Directives, Small Scale Industrial Units registered with National Small scale Industries Corporation (NSIC) under the single point registration scheme shall be exempted from submitting EMD for items registered with NSIC and upto the monetary limit specified in the registration certificate.
 - IV. MSE (Micro & Small Enterprises) registered with DIC.
 - V. MSEs who are having Udyog Aadhaar Memorandum. Micro or Small Enterprises (MSEs) registered under Gol Udyam Registration Portal, subject to any relaxation provided by statutory authority, shall not be required to submit Bid Security/EMD. Only Udyam Registration Certificate **for Micro & Small Enterprises** shall be considered for availing the various benefits under Public Procurement Policy for MSE, 2012 (PPP-MSE, 2012).



**PROCUREMENT OF VALVES FOR CONFIDENTIAL DEMO PLANT AT
MRPL, MANGALURU, KARNATAKA**

VI. Government Departments/PSU's, Any other body specified by Ministry of MSME(MoMSME), Start-ups are exempted from submission of EMD”

2.7.3 Refund of EMD :

- i. If the successful tenderer commences supplies / work and also lodges the security deposit in the manner prescribed and within the period specified, MRPL shall return to him Earnest Money Deposit, paid by him without any interest thereon.
- ii. Earnest Money Deposit will be refunded to all unsuccessful tenderers after finalization of the Tender.

3.0 SUBMISSION OF BID

3.1 For tenders invited through E-Procurement System, bids shall be submitted through **online (EPS) mode only** on the Owner's e-tendering portal for tenders invited through e-procurement mode.

3.2 Bidders to upload the Un-priced and Price part of their bids strictly in the Unpriced & Priced folders respectively at the designated place in the e-tender portal. Non Compliance to the same may lead to rejection of their offer.

3.3 **Bids submitted in any other form through Telex/ Fax/ Telegram/ E-mail/ Courier/ Registered Post/ manually shall not be accepted.**

3.4 However, documents which necessarily have to be submitted in originals like EMD (if applicable) and any other documents mentioned in the Tender Documents have to be submitted offline. The Owner shall not be responsible in any way for failure on the part of the Bidder to follow the instructions.

3.5 Bidders should avoid the last minute rush to the website for registration of user id and password, enabling of user id and mapping of Digital Signature, SI no, etc., since this exercise require activities from Consultant and EPS provider and needs time. In the event of failure in bidder's connectivity with MRPL/Service provider during the last few hours, bidder is likely to miss the deadline for bid submission. Due date extension request due to above reasons may not be entertained.

3.6 Bidders to note that the very act of using Digital Signature Certificate (DSC) for downloading the bids and uploading their offers shall be deemed to be a confirmation that they have read all pages of the bid document without any exception.

3.7 E-Procurement System Instructions :

3.7.1 Tender is invited on-line on the website www.tenderwizard.com/MRPL from **the firms** having Class IIB or above Digital Signature Certificate (DSC) (with Signing & Encryption Certificate) issued by any agency authorized by Controller of Certifying Authority (CCA), Govt. of India.

3.7.2 Offers received online on the e-procurement portal only will be considered for evaluation.

3.7.3 The server date and time as appearing on website www.tenderwizard.com/MRPL shall only be considered as cut-off time for receipt of tenders. Offers received by any other mode will not be considered.

3.7.4 Bidders are responsible for obtaining the digital certificates for participation / submission of bids at their cost.

3.7.5 The digital certificate shall be registered on the portal www.tenderwizard.com/MRPL and bidders shall upload the bid well in time.



**PROCUREMENT OF VALVES FOR CONFIDENTIAL DEMO PLANT AT
MRPL, MANGALURU, KARNATAKA**

- 3.7.6 Bidder shall download the bidding manual, system requirement and vendor registration manual and JRE setup for portal www.tenderwizard.com/MRPL to get acquainted with the procedures for submitting the online bids and load their Bids well within the time provided for bid submission to avoid last minute hassles
- 3.7.7 MRPL shall not be responsible for any delays occurred due to reasons whatsoever in receiving as well as on line submission of offers, including internet connectivity, document uploading/downloading issues etc.
- 3.7.8 Any corrigendum / amendment to the tender will be uploaded on e-Procurement site www.tenderwizard.com/MRPL and will not be published through other mode. Prospective bidders should visit the above MRPL e-Procurement site from time to time to make note of corrigendum / amendment if any.
- 3.7.9 In case of any queries regarding registration, bid submission procedure and system related, the bidder shall contact help desk of our e-procurement service provider M/s. ANTRES SYSTEM Ltd., contact person Mr. Dilip Ranganath, contact no. 0824-2882248. Email; eps@mrpl.co.in.
- 3.7.10 Support details as mentioned below;

Support Location	Name	Contact No.	Email ID
Mangalore	Mr. Dilip Ranganath	0824-2882248	eps@mrpl.co.in
Mangalore	Mr. Jayaprakash K	0824-2882298	jayaprakash.k@etenderwizard.com
Bangalore	Mr. Prabhu Swamy	080-49352000	prabhuswamy@antaressystems.com

4.0 BID OPENING AND EVALUATION

4.1 Opening of Techno-Commercial Bids:

- 4.1.1 Techno-Commercial (Un-priced) Part (Part-I) will be opened on the scheduled date and time as mentioned in Sl.No. 8 of NIT.
- 4.1.2 For E-Tenders, Bidders can also witness bid opening by logging on to the E-Tendering website through their system using their valid digital signature/certificate.

4.2 Clarification & Additional Information

- 4.2.1 The Bidder should submit all authenticated documents, information along with their Bid as per the requirement of the TENDER at the first instance.
- 4.2.2 During the Bid evaluation, Owner may, at its discretion, ask from Bidder certain clarification on the Bid, to submit additional or outstanding documents or may request to withdraw certain deviations as required, for compliance to the TENDER requirement/comparison of the Bids etc. Bidder shall submit their reply/ all such clarifications/ additional documents in Original within the cut-off date as specified in the Letter/Email.
- 4.2.3 Owner may, at its discretion, either extend such cut-off date on Bidder's request based on its merit, or evaluate the Bid based on the information available as on the last date of submission of providing such clarifications/ documents by the Bidder.

4.3 Techno-Commercial Discussions

Techno-commercial discussions with Bidder shall be arranged, if needed.



**PROCUREMENT OF VALVES FOR CONFIDENTIAL DEMO PLANT AT
MRPL, MANGALURU, KARNATAKA**

4.4 Deviations

- 4.4.1 Bidder is expected to submit Bid strictly on the terms and conditions and technical specifications contained in the TENDER document and will not stipulate any deviations/ exceptions/ alterations. In absence of any specific mention of any departure from the TENDER Document, the provisions of the TENDER Document will be binding on the Bidder.
- 4.4.2 In unavoidable circumstances, all exceptions and deviations taken by the Bidder to the stipulations of the TENDER document shall be indicated at one location in the Technical and Unpriced Commercial Part of the Bid in the format **Annexure-A** only contained in the TENDER document and not elsewhere in the unpriced (Techno-Commercial) Bid or in Priced Bid. Any exceptions or deviations indicated elsewhere in the bid shall not be construed as valid and shall not be given cognizance during Bid evaluation and signing the Purchase Order with the selected Bidder.
- 4.4.3 None of the exceptions/ deviations/ alterations in terms and conditions, technical specifications retained by Bidder shall be part of terms and conditions of the Purchase Order unless agreed by OWNER either during the techno- commercial bid evaluation or during the final negotiation (if required) with the Owner/Consultant.

4.5 Process to be confidential

Information related to the examination, clarification, evaluation and comparison of Bids and recommendations for bidder Selection shall not be disclosed to Bidder(s) or other person not officially concerned with such process. Any effort by Bidder to influence the Owner's processing of Bidding or bidders selection process may result in rejection of such Bidder's Bid.

4.6 Owner's Right to accept or Reject a Bid

Owner/Consultant reserves the right to accept or reject any Bid in whole or in part, or to annul the entire Bidding process or to reject all Bids at their sole discretion without assigning any reason whatsoever. Such decisions by Consultant/Owner shall bear no liability whatsoever consequent upon such decisions.

4.7 Rejection Criteria

The following shall lead to **rejection of Bid**:

- a) A Bid with incomplete scope of work and/ or which does not meet the technical specifications and requirements as specified in the enquiry documents shall be considered as non-responsive and rejected.
- ~~b) Non-submission of Integrity Pact along with Affidavit (Refer Clause 7.0 below)~~
- c) Non-submission of bid in English language.
- d) Non acceptance of Contract Performance Bank Guarantee (CPBG) (Refer Clause No.17.0 SPC).
- e) Non acceptance of Price Reduction Schedule (PRS)& Delayed Delivery (Refer Clause No. 18.0 of SPC).



**PROCUREMENT OF VALVES FOR CONFIDENTIAL DEMO PLANT AT
MRPL, MANGALURU, KARNATAKA**

5.0 AWARD OF WORK

5.1 Award

The Bidder, whose Bid is technically and commercially accepted by Owner as per terms and conditions of the TENDER document and its Amendment (if any), and evaluation methodology as specified under clause 4.5 above shall be issued a Letter/ Fax of Intent prior to expiry of Bid validity period. Bidder shall confirm acknowledgement by returning a signed copy of the same.

Owner/MRPL shall not be obliged to furnish any information/ clarification/ explanation to the unsuccessful Bidders regarding non-acceptance of their Bids. Owner shall correspond only with the successful Bidder.

6.0 NOTIFICATION OF AWARD

6.1 Prior to the expiration of period of offer validity Owner will notify the successful bidder in writing by fax/e-mail to be confirmed in writing, that his bid has been accepted. The notification of award / Letter of Acceptance (LOA)/ PO will constitute the formation of the Order.

6.2 The Delivery Schedule shall commence from the date of notification of award / Letter of Acceptance (LOA)/ PO.

6.3 LOA/ PO will contain price, delivery and other salient terms of bid and TENDER Document. Bidder will be required to confirm receipt of the same by returning "Copy of the LOA/ PO" duly signed and stamped by the bidder as a token of acknowledgement/Acceptance to Owner. Without any condition / deviation will be returned duly signed.

7.0 INTEGRITY PACT ALONG WITH AFFIDAVIT –NOT APPLICABLE

7.1 Bidders are required to sign and stamp the Integrity Pact (IP) along with Affidavit, as per the proforma enclosed herewith as **Annexure-C**. Proforma of Integrity Pact along with Affidavit shall be submitted in original by the Bidder along with their Bid (Part-I: Techno-Commercial Bid), duly signed by the same signatory who is authorized to sign the Bid. Bidder's failure to submit the Integrity Pact duly signed shall result in the Bid not being considered for further evaluation.

Bidders shall also be required to furnish an Affidavit confirming that he is not involved in any case of transgression in terms of Integrity Pact as per the document provided as **Annexure-C** Non Submission of Integrity Pact and Affidavit shall lead to not considering their bid for further evaluation.

7.2 RAISING DISPUTES/COMPLAINTS. (Applicable for all TENDERS where Integrity Pact is applicable.)

1 MRPL has appointed independent external monitors (IEMs). Bidders may raise disputes/ complaints, if any, with the nominated Independent External Monitors (IEM). After award of work, the IEMs shall look into any issue relating to execution of contract, if specifically raised before them.

The name, emails & Phone no. of the present IEMs are as given below:



**PROCUREMENT OF VALVES FOR CONFIDENTIAL DEMO PLANT AT
MRPL, MANGALURU, KARNATAKA**

SI No	IEMs	E-mail ID
1	Shri Akhil Agrawal IRSSE (Retd.)	akhilag21@gmail.com
2	Shri. Rajiv Kumar Srivastava IFoS (Retd.)	rksifs@gmail.com

- 2 In the event of any dispute between the management and the contractor relating to those contracts where Integrity Pact is applicable, in case, both the parties are agreeable, they may try to settle dispute through mediation before the panel of IEMs in a time bound manner. The fees/ expenses on dispute resolution shall be equally shared by both the parties.
- 3 Curriculum Vitae of Independent External Monitors (IEMs) are placed permanently on the home page of MRPL's website www.mrpl.co.in – TENDERS.

Note:

“Any routine request for tender enquiry, bid extension etc. should not be generally forwarded to IEMs unless the Bidder/vender is aggrieved/unsatisfied with any action(s) of MRPL For details of Role and functions of IEM MRPL CVC website may be referred or use the link below”.

<https://cvc.gov.in/sites/default/files/circular%20no.06-05-21.pdf>

8.0 CARTEL FORMATION:

- 8.1 In case any Bidder is found to be involved in cartel formation, their Bid will not be considered for evaluation/ placement of order. Such bidder will also be debarred from bidding in future.

9.0 FRAUDULENT PRACTICES

- 9.1 The Owner requires that Bidders observe the highest standard of ethics during the Bidding Process/execution of Contract Agreement. “Fraudulent Practice” means a misrepresentation of facts in order to influence the award of a Contract to the detriment of the Owner, and includes collusive practice among Bidders (prior to or after Bid submission) designed to establish bid prices at artificial non-competitive levels and to deprive the Owner of the benefits of free and open competition.
- 9.2 The OWNER will reject a Bid for award if it determines that the bidder recommended for award has engaged in fraudulent practices in competing for the Contract in question.

Bidder is required to furnish the complete and correct information/ documents required for evaluation of their Bids, if the information/ documents forming basis of evaluation is found to be false/ forged, the same shall be considered adequate ground for rejection of Bids

- 9.3 In case, the information/ document furnished by the Bidder forming basis of evaluation of his Bid is found to be false/ forged after the award of the contract, Owner shall have full right to terminate the contract Agreement and get the remaining job executed at the risk & cost of such Bidder without any prejudice to other rights available to Owner under the contract such as forfeiture of



**PROCUREMENT OF VALVES FOR CONFIDENTIAL DEMO PLANT AT
MRPL, MANGALURU, KARNATAKA**

CPBG/Security Deposit, withholding of payment etc.

- 9.4** In case, this issue of submission of false document comes to the notice after execution of work, Owner shall have full right to forfeit any amount due to the Bidder along with forfeiture of CPBG/Security Deposit furnished by the bidder.
- 9.5** Further, such Bidder shall be put on Blacklist/ Holiday/Negative List of Owner debarring them from future business with Owner for a time period, as per the prevailing policy of Owner.
- A. The Guidelines and procedures for Holiday Listing are available in MRPL website as Holiday Listing Policy and shall be applicable in the context of all TENDERS and consequently all Orders / Contracts / Purchase Orders. This can be accessed at URL www.mrpl.co.in .refer to TENDERS - Holiday Listing Policy.
- B. Agencies participating in TENDERS are deemed to have read, accepted and agreed for the Holiday Listing Policy of MRPL and shall not seek any damages/compensation from MRPL on account of the Holiday Listing of business with the Agency.

10.0 REQUIREMENT OF EMPLOYMENT VISA FOR FOREIGN NATIONALS

- 10.1** All foreign nationals coming to India for execution of Projects/Contracts will have to apply for Employment Visa only and that grant of Employment Visa would be subject to strict adherence of following norms:
- i) Employment Visa is granted only for the skilled and qualified professionals or to a person who is being engaged or appointed by a Company, Organisation, Industry or Undertaking etc. in India on contract or employment basis at a senior level, skilled position such as technical expert, senior executive or in managerial position etc.
- ii) Request for Employment Visa for jobs for which large number of qualified Indians are available, is not considered.
- iii) Under no circumstances an Employment Visa is granted for routine, ordinary secretarial / clerical jobs.

Bidders are advised in their own interest to check latest Visa rules from Indian Embassy / High Commission in their country in case foreign nationals are required to be deputed to India during execution of the Contract.

11.0 PRICE BID OPENING

- 11.1** Price part of only those bidders, whose bids are considered techno-commercially acceptable, shall be opened. Bidders selected for opening of their price bids shall be informed about the date of price bid opening.
- 11.2** The Price Bid opening shall be done of e-tender portal and Bidders can also witness bid opening by logging on to the E-Tendering website through their system using their valid digital signature/certificate.

**12.0 INFORMATION REQUIRED FROM FOREIGN SUPPLIERS/
CONTRACTORS FOR ALL CASES OTHER THAN SUPPLY ORDERS**

All prices must be gross of Indian Income Taxes.

- 12.1** It is mandatory for the foreign supplier/contractor to furnish the following information in case his receipts are subject to tax deduction at source in



**PROCUREMENT OF VALVES FOR CONFIDENTIAL DEMO PLANT AT
MRPL, MANGALURU, KARNATAKA**

India:

- a) PAN No. as per the Indian Income Tax requirements failing which the Supplier/Contractor shall be responsible for any additional tax deduction at source as per the provisions of the Indian Income Tax Act/Rules and the same shall be deducted from the payment made to supplier/contractor.

In case the foreign bidder does not have Permanent Account Number (PAN), he shall furnish the following information/documents:

- Name, e-mail ID, contact number.
 - Address in the country of which the deductee is a resident.
 - Tax Residency Certificate (TRC) from the Government of that country.
 - Tax Identification Number (TIN) / Unique Number of the deductee in the country of his residence.
- b) Tax Residency Certificate (TRC) containing prescribed particulars as per the enclosed format (**Annexure F**) from the Government of foreign country in order to claim the benefits of DTAA as per the Indian Income Tax requirements failing which the relief under DTAA will not be available and consequently the higher rate of withholding tax @ 25% will be applicable and deducted from the payment made to supplier/contractor (i.e., non-resident taxpayer). The TRC shall be duly verified by the Government of the country of which the assessee claims to be a resident for the purposes of tax.
- c) In addition to TRC, bidder in order to claim the benefits of DTAA shall also submit additional information in form no. 10F. Form 10F has to be signed & verified by the assessee himself. (**Refer Annexure F**)

12.2 If some information is already contained in TRC, the bidder shall not be required to provide that information in Form no. 10F but even then Form no. 10F is required to be provided by the bidder. However, the bidder may write Not Applicable in the relevant column in case that information is already contained in TRC.

12.3 Any other document required before release of any payment as per the Statute applicable for the Payment. The above shall be furnished before release of any payment.

13.0 COMPLIANCE TO REQUIREMENT TO TENDER DOCUMENT

Bidder shall submit the compliance to the TENDER document as per the performa attached as **Annexure – G**. Non-compliant bids may be rejected and clarifications may not be sought if sufficient compliant bids are received.

14.0 BANK GUARANTEE (BG) VERIFICATION UNDER THE “STRUCTURED FINANCIAL MESSAGING SYSTEM” (SFMS).

The irrevocable Bank Guarantee (BG) in the prescribed TENDER format if submitted against Earnest Money Deposit / CPBG/ SD/ Mobilisation advance shall be subject to verification from the issuing Bank, the email ID of bank for the same must be incorporated in the BG.

The BG issued by the issuing Bank on behalf of Bidder/Contractor/Supplier in favour of “Mangalore Refinery and Petrochemicals Limited” shall be in paper form and also be made available under the “Structured Financial Messaging System” (SFMS).



**PROCUREMENT OF VALVES FOR CONFIDENTIAL DEMO PLANT AT
MRPL, MANGALURU, KARNATAKA**

A separate advice of the BG will invariably be sent by the issuing bank to the beneficiary's 'Bank through SFMS and SFMS transmission message reference number (currently 32 digits code) is to be sent along with BG directly to MRPL through speed post/regd. Post.

The details of beneficiary for issue of BG under SFMS platform is furnished below:

Name of Beneficiary: Mangalore Refinery and Petrochemicals Limited

Beneficiary Bank, Branch and address: Union Bank of India (Erstwhile Corporation Bank), MRPL Project Site, Kuthethoor Post Mangaluru 575030, Karnataka

IFSC code: UBIN0905925

SWIFT Code: UBININBBMAP

MICR Code: 575026018

Any bank guarantee submitted in physical mode which cannot be verifiable through SFMS will not be accepted under any circumstance.



**PROCUREMENT OF VALVES FOR CONFIDENTIAL DEMO PLANT AT
MRPL, MANGALURU, KARNATAKA**

ANNEXURE – A TO ITB EXCEPTIONS AND DEVIATIONS STATEMENT

FORMAT

SI. NO.	TENDER DOCUMENT REFERENCE		SUBJECT	DEVIATIONS
	PAGE NO.	CLAUSE NO.		

NOTE:

1. Bidder is required to comply with the requirements of the TENDER Document, and not to stipulate any exceptions or deviations. In case it is unavoidable, Bidder may stipulate exceptions to requirements of TENDER document in the above format only.
2. All exceptions and deviations taken by Bidder to the stipulations of the TENDER document shall be indicated at one location in a separate section titled "Exceptions and Deviations" in the techno-commercial unpriced part of the Bid as per the above format only and not in the TENDER document or in the Price Bid.
3. Any exceptions or deviations indicated elsewhere in the Bid and / or in other format shall not be taken cognizance of and Bid of the Bidder shall be deemed considered without having any such deviations taken by the Bidder.

SIGNATURE OF BIDDER: _____

NAME OF BIDDER: _____



**PROCUREMENT OF VALVES FOR CONFIDENTIAL DEMO PLANT AT
MRPL, MANGALURU, KARNATAKA**

ANNEXURE – B TO ITB

VENDOR FORM FOR ELECTRONIC FUNDS TRANSFER PAYMENT & TAX DETAILS

**Please use additional copies of this form if your Company has additional Branches/ Divisions dealing with MRPL/ if
Material/ Service/ Invoice will be provided from different GST Nos.**

Vendor data - ver-9

To: GGM – Materials	
Mangalore Refinery & Petrochemicals Ltd., Kuthethoor P.O., via Katipalla, Mangalore. (Karnataka), Pin Code-575030, INDIA	
The following is a confirmation/ updation of our bank account details and I/we hereby affirm our choice to opt for payment of amounts due to us under various contracts through electronic mode.	
<u>1. Vendor/ Contractor particulars:</u>	
(i) Name of the Company:	
(ii) Corporate Identity No. (CIN)	
(iii) Existing Vendor Code (given by MRPL)	
(iv) Complete Postal Address:	
(v) Pin code/ ZIP code:	
(vi) Telephone nos. (with country/area codes):	
(vii) Fax No.: (with country/area codes):	
(viii) Cell phone Nos.:	
(ix) Contact persons /Designation:	
(x) Email IDs:	
<u>2. Bank Account Particulars:</u>	
(i) Name of the Account holder:	
(ii) Complete Bank Account No. (for Electronic Funds Transfer):	
(iii) Account type :	
(iv) Bank Name :	



**PROCUREMENT OF VALVES FOR CONFIDENTIAL DEMO PLANT AT
MRPL, MANGALURU, KARNATAKA**

(v)	Bank Branch:	
(vi)	Bank Branch Contact Nos.:	
(vii)	11 Digit IFS Code (for Bank Branches in India)	
(viii)	Swift Code (for Bank Branches not in India)	

3. Tax Registration numbers: *(Please fill in the applicable fields and attach relevant proofs)

(i)	Income Tax PAN no.:	
(ii)	Vendor type as per GST Act (tick any one)	<input type="checkbox"/> Registered <input type="checkbox"/> Not Registered <input type="checkbox"/> Composite SEZ
(iii)	GST No.:	
(iv)	TAN No.:	
(v)	Registered address as per GST No.	
(vi)	Contact Names, Nos.& email IDs for GST matters (Please mention primary and secondary contacts):	
	Accounts Deptt.	1. 2.
	Material Dispatch Deptt./ Services Deptt.	1. 2.
(vii)	Are you registered under TReDS	No/Yes with RXIL/ A-TREDS/I9xchange 10 digit Reg No-

4. Organization information (MSMEs refer to Micro, Small and Medium Enterprises Development Act, 2006):

(i)	Company /Partnership Firm /Proprietary Concern / Society/Trust /NGO/Others (Please Specify):	
(ii)	Whether Proprietor/ Partner belongs to SC/ ST category. (Please specify names and percentage of shares held by SC/ST Partners):	
(iii)	Micro/Small / Medium Enterprise/ SSI/ Govt. Deptt./ PSU/ Others:	



**PROCUREMENT OF VALVES FOR CONFIDENTIAL DEMO PLANT AT
MRPL, MANGALURU, KARNATAKA**

(iv)	Name of MSME Registering Body (NSIC/ DIC/ KVIC/KVIB etc.):	
(v)	MSME Registration no. (with copy of registration)	
(vi)	Udyog Aadhaar Memorandum no.	
(vii)	MSME-Women Entrepreneur	No/Yes
(viii)	Start-Up recognized by DIPP, Ministry of Commerce, Govt of India	No/Yes, copy of certificate from DIPP attached
I/we hereby confirm that the particulars given above are correct and complete and also undertake to advise any future changes to the above details.		
 <hr/>		
Name, Seal & Signature of Authorized Signatory for the Vendor with date		
<u>TO BE FILLED BY AUTHORISED BANKER OF THE VENDOR:</u>		
Certified that the Particulars as in Sr. No. 2 above are correct as per our records		



**PROCUREMENT OF VALVES FOR CONFIDENTIAL DEMO PLANT AT
MRPL, MANGALURU, KARNATAKA**

ANNEXURE – C TO ITB

INTEGRITY PACT

between

Mangalore Refinery and Petrochemicals Ltd (MRPL) hereinafter referred to as "The Principal",

and

M/s..... hereinafter referred to as "The Bidder/Contractor"

Preamble

The Principal intends to award, under laid down organizational procedures, contract/s for procurement of products / services vide tender No. dtd The Principal values full compliance with all relevant laws of the land, rules, regulations, economic use of resources, and of fairness and transparency in its relations with its Bidder/s and Contractor/s.

In order to achieve these goals, the Principal will appoint an independent External Monitor (IEM) who will monitor the tender process and the execution of the contract for compliance with the principles mentioned above.

Section 1 - Commitments of the Principal

- (1) The Principal commits itself to take all measures necessary to prevent corruption and to observe the following principles:-
1. No employee of the Principal, personally or through family members, will in connection with the tender for, or the execution of a contract, demand, take a promise for or accept, for self or third person, any material or immaterial benefit which the person is not legally entitled to.
 2. The Principal will, during the tender process treat all Bidders with equity and reason. The principal will in particular, before and during the tender process, provide to all Bidders the same information and will not provide to any bidder confidential/additional information through which the Bidder could obtain an advantage in relation to the tender process or the contract execution.
 3. The Principal will exclude from the process all known prejudiced persons.
- (2) If the Principal obtains information on the conduct of any of its employees which is a criminal offence under the the IPC/PC Act, or if there be a substantive suspicion in this regard, the Principal will inform the Chief Vigilance officer and in addition can initiate disciplinary actions.

For "The Principal"

शिवसुब्रमणी. के SIVASUBRAMONI. K
मुख्य महा प्रबंधक (परियोजना - वाणिज्य)
CGM (Projects - Commercial)
मंगलूरु रिफाइनरी एंड पेट्रोकेमिकल्स लिमिटेड
Mangalore Refinery & Petrochemicals Ltd
मंगलूरु Mangaluru - 575 030

For "The Bidder/Contractor"

1/4

**PROCUREMENT OF VALVES FOR CONFIDENTIAL DEMO PLANT AT
MRPL, MANGALURU, KARNATAKA**

Section 2 – Commitments of the Bidder(s)/Contractor(s)

- (1) The Bidder(s) / Contractor(s) commit themselves to take all measures necessary to prevent corruption. The Bidder(s) / Contractor(s) commit themselves to observe the following principles during his participation in the tender process and during the contract execution.
1. The Bidder(s)/Contractor(s) will not, directly or through any other person or firm, offer, promise or give to any of the Principal's employees involved in the tender process or the execution of the contract or to any third person any material or immaterial benefit which he/she is not legally entitled to, in order to obtain in exchange any advantage of any kind whatsoever during the tender process or during the execution of the contract.
 2. The Bidder(s)/Contractor(s) will not enter with other Bidders into any undisclosed agreement or understanding, whether formal or informal. This applies in particular to prices, specifications, certifications, subsidiary contracts, submission or non-submission of bids or any other actions to restrict competitiveness or to introduce cartelization in the bidding process.
 3. The Bidder(s)/Contractor(s) will not commit any offence under the relevant IPC/PC Act, further the Bidder(s)/Contractor(s) will not use improperly, for purposes of competition or personal gain, or pass on to others any information or document provided by the Principal as part of the business relationship, regarding plans, technical proposals and business details, including information contained or transmitted electronically.
 4. The Bidders(s) / Contractor(s) of foreign origin shall disclose the name and address of the Agents/representatives in India, if any. Similarly the Bidder(s)/Contractor(s) of Indian Nationality shall furnish the name and address of the foreign principals, if any. Further details as mentioned in the "Guidelines on Indian Agents of Foreign Suppliers" shall be disclosed by the Bidder(s) / Contractor(s). Further, as mentioned in the Guidelines all the payments made to the Indian agent / representative have to be in Indian Rupees only.
 5. The Bidder(s) / Contractor(s) will, when presenting his bid, disclose any and all payments made, is committed to or intends to make to agents, brokers or any other intermediaries in connection with the award of the contract.
 6. Bidder(s) / Contractor(s) who have signed the Integrity Pact shall not approach the courts while representing the matter to IEMs and shall wait for the decision in the matter.
- (2) The Bidder / Contractor will not instigate third persons to commit offences outlined above or be an accessory to such offences.

Section 3 - Disqualification from tender process and exclusion from future contracts

If the Bidder(s) / Contractor(s), before award or during execution has committed a transgression through a violation of Section 2 or in any other form such as to put his reliability or credibility in question, the Principal is entitled to disqualify the Bidder(s) / Contractor(s) from the tender process or take action as per the procedure mentioned in the "Policy for Holiday Listing". Copy of the "Policy for Holiday Listing" is placed at MRPL Website.

Section 4 - Compensation for Damages

- (1) If the Principal has disqualified the Bidder(s) from the tender process prior to the award according to Section 3, the Principal is entitled to demand and recover from the Bidder liquidated damages equivalent to Earnest Money Deposit / Bid Security.
- (2) If the Principal has terminated the contract according to Section 3; or if the Principal is entitled to terminate the contract according to Section 3, the Principal shall be entitled to demand and recover from the Contractor liquidated damages of the contract value or the amount equivalent to Security Deposit / Performance Bank Guarantee.

Section 5 - Previous transgression

- (1) The Bidder declares that no previous transgressions occurred in the last 3 years with any other Company in any country conforming to the anti-corruption approach or with any other Public Sector Enterprise in India that could justify his exclusion from the tender process.
- (2) If the Bidder makes incorrect statement on this subject, he can be disqualified from the tender process or Action can be taken as per the procedure mentioned in "Policy for Holiday Listing".

For "The Principal"

For "The Bidder/Contractor"

शिवसुब्रमणी के SIVASUBRAMONI. K
मुख्य प्रबंधक (परिचालना - वाणिज्य)
CGM (Projects - Commercial)
मंगलूर रिफाइनरी एंड पेट्रोकेमिकल् लिमिटेड
Mangalore Refinery & Petrochemicals Ltd
Mangalore - 575 030

2/4

**PROCUREMENT OF VALVES FOR CONFIDENTIAL DEMO PLANT AT
MRPL, MANGALURU, KARNATAKA**

Section 6 - Equal treatment of all Bidders / Contractors / Subcontractors

- (1) In case of a joint venture, all the partners of the joint venture should sign the Integrity Pact. In case of sub-contracting, the Principal Contractor shall take the responsibility of the adoption of Integrity Pact by the Sub-Contractor. It is to be ensured that all sub-contractors also sign the Integrity Pact.
- (2) The Principal will enter into agreements with identical conditions as this one with all Bidders, Contractors & Subcontractors.
- (3) The Principal will disqualify from the tender process all bidders who do not sign this pact or violate its provisions.

Section 7 - Criminal charges against violating Bidders / Contractors / Subcontractors

If the Principal obtains knowledge of conduct of a Bidder, Contractor or Subcontractor, or of an employee or a representative or an associate of a Bidder, Contractor or Subcontractor which constitutes corruption, or if the Principal has substantive suspicion in this regard, the Principal will inform the same to the Chief Vigilance Officer.

Section 8 - Independent External Monitor

- (1) The Principal appoints competent and credible Independent External Monitor for this Pact after approval by Central Vigilance Commission. The task of the Monitor is to review independently and objectively, whether and to what extent the parties comply with the obligations under this agreement.
- (2) The Monitor is not subject to instructions by the representatives of the parties and performs his/her functions neutrally and independently. The Monitor would have access to all Contract documents, whenever required. It will be obligatory for him / her to treat the information and documents of the Bidders/Contractors as confidential. He / She reports to the Managing Director, MRPL.
- (3) The Bidder(s)/Contractor(s) accepts that the Monitor has the right to access without restriction to all project documentation of the Principal including that provided by the Contractor. The Contractor will also grant the Monitor, upon his/her request and demonstration of a valid interest, unrestricted and unconditional access to his project documentation. The same is applicable to Subcontractors.
- (4) The Monitor is under contractual obligation to treat the information and documents of the Bidder(s) / Contractor(s) / Subcontractor(s) with confidentiality. The Monitor has also signed declarations on Non-Disclosure of Confidential Information and of 'Absence of Conflict of Interest'. In case of any conflict of interest arising at a later date, the IEM shall inform Managing Director, MRPL and rescue himself / herself from that case.
- (5) The Principal will provide to the Monitor sufficient information about all meetings among the parties related to the Project provided such meetings could have an impact on the contractual relations between the principal and the Contractor. The parties offer to the Monitor the option to participate in such meetings.
- (6) As soon as the Monitor notices, or believes to notice, a violation of this agreement, he/she will so inform the Management of the Principal and request the Management to discontinue or take corrective action, or to take other relevant action. The monitor can in this regard submit non-binding recommendations. Beyond this, the Monitor has no right to demand from the parties that they act in a specific manner, refrain from action or tolerate action.
- (7) The Monitor will submit a written report to the Managing Director, MRPL within 8 to 10 weeks from the date of reference or intimation to him by the 'principal' and, should the occasion arise, submit proposals for correcting problematic situations.
- (8) If the Monitor has reported to the Managing Director MRPL, a substantiated suspicion of an offence under IPC/PC Act, and the Managing Director MRPL has not, within reasonable time taken visible action to proceed against such offence or reported it to the Chief Vigilance Officer, the Monitor may also transmit this information directly to the Central Vigilance Commissioner.
- (9) The word "Monitor" would include both singular and plural.

For "The Principal"

(निदेशावली के SIVASUBRAMONI, K
मुख्य महा अधिकारी (परियोजना - वाणिज्य)
CGM (Projects - Commercial)
बंगलूर रिफाइनरी एंड पेट्रोकेमिकल्स लिमिटेड
Bengaluru Refinery & Petrochemicals Ltd
मंगलूरु - 575 030

For "The Bidder/Contractor"



**PROCUREMENT OF VALVES FOR CONFIDENTIAL DEMO PLANT AT
MRPL, MANGALURU, KARNATAKA**

Section 9 – Pact Duration

This Pact begins when both parties have legally signed it. It expires for the Contractor 12 months after the last payment under the respective contract, and for all other Bidders 6 months after the contract has been awarded. Any violation of the same would entail disqualification of the bidders and exclusion from future business dealings.

If any claim is made/lodged during this time, the same shall be binding and continue to be valid despite the lapse of this pact as specified above, unless it is discharged / determined by Managing Director of MRPL.

Section 10 – Other Provisions

- (1) This agreement is subject to Indian Law, Place of performance and jurisdiction is the Registered Office of the Principal, i.e. Mangalore.
- (2) Changes and supplements as well as termination notices need to be made in writing. Side Agreements have not been made.
- (3) If the Contractor is a partnership or a consortium, this agreement must be signed by all partners or consortium members.
- (4) Should one or several provisions of this agreement turn out to be invalid, the remainder of this agreement remains valid. In this case, the parties will strive to come to an agreement to their original intentions.
- (5) Issues like Warranty / Guarantee etc. shall be outside the purview of IEMs.
- (6) In the event of any contradiction between the Integrity Pact and its Annexure, the clause in the Integrity Pact will prevail.

For "The Principal"

शिवसुब्रमणी के SIVASUBRAMONI K
मुख्य महा व्यवधक (परियोजना - वाणिज्य)
CGM (Projects - Commercial)
मंगलूर रिफाइनरी एंड पेट्रोकेमिकल्स लिमिटेड
Mangalore Refinery & Petrochemicals Ltd
मंगलूर Mangaluru - 575 030

Place: Mangalore

Date:.....

For "The Bidder/Contractor"
(Name & Signature with Seal)

Witness 1:.....

Witness 2:.....



**PROCUREMENT OF VALVES FOR CONFIDENTIAL DEMO PLANT AT
MRPL, MANGALURU, KARNATAKA**

FORMAT FOR FURNISHING AFFIDAVIT W.R.T. INTEGRITY PACT

FORMAT OF AFFIDAVIT

AFFIDAVIT OF..... S/o D/o , resident of

.....
EMPLOYED AS.....W
ITH

.....HAVING OFFICE AT.....
.....

.....PIN

I, the above named deponent do hereby solemnly affirm and state as under:-

1. That I am the authorized representative and signatory of M/s
2. Bidding entity M/s _____ is not involved in any case of transgression in terms of Integrity Pact. Submitted for TENDER No _____
3. I depose accordingly,

DEPONENT

VERIFICATION

I, the deponent above named, do hereby verify that the factual contents of this Affidavit are true and correct. No part of it is false and nothing material has been concealed there from.

Verified at on this day of..... 20

DEPONENT

(on non-judicial stamp paper of appropriate value & duly notarized)



**PROCUREMENT OF VALVES FOR CONFIDENTIAL DEMO PLANT AT
MRPL, MANGALURU, KARNATAKA**

ANNEXURE-D TO ITB

ANNUAL TURNOVER DETAILS

A. ANNUAL TURNOVER

Annual Turnover data for the last 3 financial years ending 31stMarch /
31stDecember

FINANCIAL YEAR (F.Y.)	ANNUAL TURNOVER (indicate currency) [As per Audited Financial Statement]	ANNUAL TURNOVER (In US\$, for Foreign Bidder)[As on Date of Audited Financial Statement]	Bidder's Currency to US\$ conversion factor
F.Y. _____			
F.Y. _____			
F.Y. _____			
AVERAGE TURNOVER			



**PROCUREMENT OF VALVES FOR CONFIDENTIAL DEMO PLANT AT
MRPL, MANGALURU, KARNATAKA**

ANNEXURE-E TO ITB

**PROFORMA FOR ACKNOWLEDGEMENT LETTER OF TENDER DOCUMENT
(TO BE SUBMITTED IN BIDDER'S OWN LETTERHEAD)**

Ref No.:

DATE:

To

Attn. :

SUBJECT:	TENDER FOR SUPPLY OF VALVES FOR CONFIDENTIAL DEMO PLANT AT MRPL, MANGALURU, KARNATAKA . Tender No. 3200000897
-----------------	--

Dear Sir,

We hereby acknowledge receipt of a complete set of TENDER Document along with all enclosures for the subject work as per the Master Index for preparation and submission of the Bid.

We undertake that the contents of the above TENDER Document shall be kept confidential and further that specifications and documents shall not be transferred and that the said documents are to be used only for the purpose for which they are intended.

A) We intend to bid as requested for the subject works and furnish following details with respect to our quoting office:

- (i) POSTAL ADDRESS : _____

- (ii) TELE PHONE NUMBER : _____
(with ISD code)
- (iii) MOBILE NO. : _____
- (iv) TELEFAX NUMBER : _____
- (v) CONTACT PERSON : _____
- (vi) DESIGNATION : _____
- (vii) EMAIL ADDRESS : _____
- (viii) REGISTERED OFFICE : _____



**PROCUREMENT OF VALVES FOR CONFIDENTIAL DEMO PLANT AT
MRPL, MANGALURU, KARNATAKA**

B) Contact person at Delhi, if any: _____

(i) POSTAL ADDRESS :

(ii) TELE PHONE NUMBER
(with ISD code) :

(iii) MOBILE NO. :

(iv) TELE FAX NUMBER :

(v) CONTACT PERSON :

(vi) DESIGNATION :

(vi) EMAIL ADDRESS :

C) We are unable to bid for the reasons given below and we are returning the entire set of TENDER Documents.

Reasons for non-submission of Bid:

BIDDER'SNAME : _____

SIGNATURE : _____

NAME : _____

DESIGNATION : _____

DATE : _____

NOTE: Bidder is requested to furnish the details mentioned at (A) and (B) or (C) within 7 days after receipt of TENDER Document.

(STAMP AND SIGNATURE OF BIDDER)



**PROCUREMENT OF VALVES FOR CONFIDENTIAL DEMO PLANT AT
MRPL, MANGALURU, KARNATAKA**

**ANNEXURE-F TO ITB
FORM NO. 10F, TRC
AND PERMANENT ESTABLISHMENT**



PROCUREMENT OF VALVES FOR CONFIDENTIAL DEMO PLANT AT
MRPL, MANGALURU, KARNATAKA

ON THE LETTER HEAD

[FORMAT FOR PERMANENT ESTABLISHMENT CERTIFICATE]

Dear Sir,

This is to certify that

- We M/s _____ are >> individual or sole proprietor or Partnership firm or limited company>> registered/incorporated under the laws of _____
- We are liable to tax in _____. Our tax registration number is _____
- We are tax resident of _____ within the meaning of Article 5 of DTAA entered in to between India and _____
- We are **entitled/not entitled** to the benefits of the DTAA entered into between India and _____
- We **have / do not have any** Permanent Establishment in India within the meaning of Article 5 of the DTAA.
- We **have / do not have any** office or establishment or fixed place of business in India.

Thanking you,

Yours faithfully,

(Stamp & Signature Required)



**PROCUREMENT OF VALVES FOR CONFIDENTIAL DEMO PLANT AT
MRPL, MANGALURU, KARNATAKA**

In case the vendor has any Permanent Establishment in India within the meaning of Article 5 of the DTAA,

OR

The vendor has any office or establishment or fixed place of business in India,

ON THE LETTER HEAD

Dear Sir,

This is to certify that

- (a) Whether M/shas any Permanent Establishment (PE) in India through which M/s is directly or indirectly carrying on activity of supply under PO No:placed by M/s Mangalore Refinery and Petrochemicals Limited on M/s.....
YES/NO
- (b) Whether the remittance vide PO No: placed by M/s Mangalore Refinery and Petrochemicals Limited on M/s is attributable to or connected with such Permanent Establishment(PE)
YES/NO
- (c) If the reply to Item no. (b) Above is "Yes" the amount of Income comprised in such remittance which is liable to tax in India Amount in INR.....
- (d) If the reply to Item no. (b) Above is "NO" the reasons in brief thereof.

Thanking you,

Yours truly,

(Stamp & Signature)



**PROCUREMENT OF VALVES FOR CONFIDENTIAL DEMO PLANT AT
MRPL, MANGALURU, KARNATAKA**

**In case the vendor does not have any Permanent Establishment in India
within the meaning of Article 5 of the DTAA,**

ON THE LETTER HEAD

Subject : No Permanent Establishment Certificate
Ref : PO No : _____ Dt: _____
Invoice No: _____ Dt: _____

Dear Sir,

This is to certify that M/s _____ is a tax resident of _____ and does not have any Permanent Establishment in India as per the provisions of Article 5 of The DTAA between India and _____ in respect of the services to be rendered Under the captioned Agreement entered into with your company.

We also clarify that we do not carry on any business through any agent by a Permanent Establishment in India with regard to the above.

Yours truly,
For M/s

(Stamp & Signature of Bidder)



**PROCUREMENT OF VALVES FOR CONFIDENTIAL DEMO PLANT AT
MRPL, MANGALURU, KARNATAKA**

[TRC CERTIFICATE]

TRC obtained by the Non-resident from Government of foreign country shall contain the following particulars:

- (i) Name of the assessee;
- (ii) Status (individual, company, firm etc.) of the assessee;
- (iii) Nationality (in case of individual);
- (iv) Country or specified territory of incorporation or registration (in case of others);
- (v) Assessee's tax identification number in the country or specified territory of residence or in case no such number, then, a unique number on the basis of which the person is identified by the Government of the country or the specified territory;
- (vi) Residential status for the purposes of tax;
- (vii) Period for which the certificate is applicable; and
- (viii) Address of the applicant for the period for which the certificate is applicable;



**PROCUREMENT OF VALVES FOR CONFIDENTIAL DEMO PLANT AT
MRPL, MANGALURU, KARNATAKA**

FORM-10F

ON THE LETTER HEAD

[See sub-rule (1) of rule 21AB]

Information to be provided under sub-section (5) of section 90 or sub-section (5) of section 90A of the Income-tax Act, 1961

I, *son/daughter of Shri..... in the capacity of(designation) do provide the following information, relevant to the previous year..... *in my case/in the case of..... for the purposes of sub-section

(5) of* section 90/section90A:—

SI No	Nature of Information	:	Details #
(i)	Status (individual; company, firm etc.) of the assessee	:	
(ii)	Permanent Account Number (PAN) of the assessee if allotted	:	
(iii)	Nationality (in the case of an individual) or Country or specified territory of incorporation or registration (in the case of others)	:	
(iv)	Assessee's tax identification number in the country or specified territory of residence and if there is no such number, then, a unique number on the basis of which the person is identified by the Government of the country or the specified territory of which the assessee claims to be a resident	:	
(v)	Period for which the residential status as mentioned in the certificate referred to in sub-section (4) of section 90 or sub-section (4) of section 90A is applicable	:	
(vi)	Address of the assessee in the country or territory outside India during the period for which the certificate, mentioned in (v) above, is applicable	:	

2. I have obtained a certificate to in sub-section (4) of section 90 of sub-section (4) of section 90A from the Government of (name of country or specified territory outside India)

F.NO.142/16/2013-TPL]/SO 2331(E)

Signature:

Name:

Address:

Permanent Account Number:

Verification

I, do hereby declare that to the best of my knowledge and belief what is stated above is correct complete and is truly stated.

Verified today the day of..... Signature of the person providing the information

Place:

Notes:

a. * Delete whichever is not applicable

b. # Write N.A. if the relevant information forms part of the certificate referred to in sub-section (4) of section 90 or sub-section (4) of section90A.



**PROCUREMENT OF VALVES FOR CONFIDENTIAL DEMO PLANT AT
MRPL, MANGALURU, KARNATAKA**

ANNEXURE –G TO ITB

COMPLIANCE TO REQUIREMENT TO TENDER DOCUMENT

TENDER No: 3200000897

**ITEM: PROCUREMENT OF VALVES FOR CONFIDENTIAL DEMO PLANT AT MRPL, MANGALURU,
KARNATAKA**

We * hereby agree to fully comply with, abide by and accept without variation, deviation or reservation all technical, commercial and other condition whatsoever of the TENDER Documents including all Addenda / Corrigenda / Clarifications issued.

Any and all deviations, variations, objections or reservations whatsoever hereto set out, given or indicated in our offer, clarifications, correspondence, communications, or otherwise stands null and void.

**

For & on behalf of

Authorised signatory

* Here fill in the name of bidder.

** The Compliance Letter must be signed by the person (s) authorised to sign the bid.



**PROCUREMENT OF VALVES FOR CONFIDENTIAL DEMO PLANT AT
MRPL, MANGALURU, KARNATAKA**

ANNEXURE – H TO ITB

**DECLARATION OF BLACKLISTING BY ANY GOVT DEPARTMENT / PSU
(ON LETTERHEAD OF BIDDER)**

TENDER No: 3200000897

**ITEM: PROCUREMENT OF VALVES FOR CONFIDENTIAL DEMO PLANT AT MRPL, MANGALURU,
KARNATAKA.**

I hereby declare that _____(Name of the bidder) is not banned or delisted or
blacklisted by any government department / Public Sector Undertaking on due date of submission of bid.

For & on behalf of
Authorised signatory of Bidder



**PROCUREMENT OF VALVES FOR CONFIDENTIAL DEMO PLANT AT
MRPL, MANGALURU, KARNATAKA**

ANNEXURE – I TO ITB

DECLARATION FOR LIQUIDATION/ COURT RECEIVERSHIP

TENDER No: 3200000897

**ITEM: PROCUREMENT OF VALVES FOR CONFIDENTIAL DEMO PLANT AT MRPL,
MANGALURU, KARNATAKA.**

We confirm that we are not under any liquidation, court receivership or similar proceedings.

BIDDER'S SIGNATURE

NAME:
DESIGNATION
DATE:
SEAL/STAMP

Note:

1. This certificate should be issued in the Letter Head of the Bidder.



**PROCUREMENT OF VALVES FOR CONFIDENTIAL DEMO PLANT AT
MRPL, MANGALURU, KARNATAKA**

ANNEXURE – J TO ITB

Proforma for Earnest Money Deposit

The irrevocable Bank Guarantee (BG) in the following prescribed format if submitted against Earnest Money Deposit shall be subject to verification from the issuing Bank, the email ID of bank for the same must be incorporated in the BG.

The BG issued by the issuing Bank on behalf of Bidder/Contractor/Supplier in favour of “Mangalore Refinery and Petrochemicals Limited” shall be in paper form and also be made available under the “Structured Financial Messaging System” (SFMS).

A separate advice of the BG will invariably be sent by the issuing bank to the beneficiary’s Bank through SFMS and SFMS transmission message reference number (currently 32digits code) is to be sent along with BG directly to MRPL through speed post/regd. Post.

The details of beneficiary for issue of BG under SFMS platform is furnished below: **(Procedure to submit the BG and MRPL Bank details are attached with Tender under Exhibit-10)**

Name of Beneficiary: Mangalore Refinery and Petrochemicals Limited

Beneficiary Bank, Branch and address: Union Bank of India (Erstwhile Corporation Bank),
MRPL Project Site, Kuthethoor Post Mangalore
575030, Karnataka

IFSC code: UBIN0905925

SWIFT Code: UBININBBMAP

MICR Code: 575026018

Any bank guarantee submitted in physical mode which cannot be verifiable through SFMS will not be accepted under any circumstances



**PROCUREMENT OF VALVES FOR CONFIDENTIAL DEMO PLANT AT
MRPL, MANGALURU, KARNATAKA**

PROFORMA OF BANK GUARANTEE

(FOR EARNEST MONEY DEPOSIT AS APPLICABLE)
(On non-judicial paper of appropriate value)

To

Mangalore Refinery and Petrochemicals Limited

Mangalore

Dear Sirs,

In consideration of Mangalore Refinery and Petrochemicals Limited , having its Registered Office at Kuthethoor P.O Via Katipalla , Mangalore - (hereinafter called "the Owner" which expression shall include its successors and assigns), having agreed inter alia to consider the tender of (Name of the Tenderer) having its Head Office/Registered Office at (Address of the Tenderer) (hereinafter called the "Tenderer" which expression shall include its successors and assigns), for the work of..... (Name of the Project/ Work) at..... to be awarded under Tender No..... Upon the Tenderer furnishing an undertaking from the Bank as hereinafter appearing in lieu of cash deposit of the Earnest Money.

We (Name of the Bank), a Bank Constituted/Registered under the Act, having our Head Office/Registered Office at (hereinafter called the "Bank" which expression shall include its successors and assigns), at the request of the Tenderer and with the intent to bind the Bank and its successors and assigns do hereby unconditionally and irrevocably undertake to pay the Owner at Mangalore forthwith on first demand without protest or demur or proof or satisfaction or condition and without reference to the Tenderer, all sums payable by the Tenderer as and by way of Earnest Money to the Owner, upto an aggregate limit of (Amount in figures and words).

AND THE BANK DOTH HEREBY FURTHER AGREES AS FOLLOWS:

1. This Guarantee/Undertaking shall be a continuing guarantee and shall remain in full force and effect for all claims or demands made by the Owner on the Bank until the Owner discharges this Guarantee/Undertaking subject, however, that the Owner shall have no claims under this Guarantee/Undertaking after the midnight of200..... or any written extension(s) thereof.
PROVIDED that if the aforesaid work tendered for or any part thereof shall be awarded to the Tenderer on or before the said date, whether on the basis of accompanying tender or any other basis, then the validity of this guarantee/undertaking shall stand automatically extended for all claims and demands made by the Owner for further three months.
The Owner shall have the fullest liberty without reference to the Bank and without affecting in any way the liability of the Bank under this Guarantee/Undertaking at any time and/or from time to time any wise to postpone and/or vary any of the powers, rights, and obligations exercisable by the Owner against the Tenderer and either to enforce or to forbear from



**PROCUREMENT OF VALVES FOR CONFIDENTIAL DEMO PLANT AT
MRPL, MANGALURU, KARNATAKA**

enforcing all or any of the terms and conditions of or governing the said Tender and/or any contract consequent upon any award of work or the said Earnest Money Deposit or the securities available to the Owner or any of them and the Bank shall not be released from its liability under these Presents and the Liability of the Bank

2. hereunder shall remain in full force and effect notwithstanding any exercise by the Owner of the liberty with reference to any or all the matters aforesaid or by reason of any other act, matter or thing whatsoever which under law relating to the sureties or otherwise which could, but for this provision have the effect of releasing the Bank from all or any of its obligations hereunder or any part thereof, and the Bank specifically waives any and all contrary rights whatsoever.
3. It shall not be necessary for the Owner to proceed against the Tenderer before proceeding against the Bank and the Guarantee/Undertaking herein contained shall be enforceable against the Bank as principal debtor notwithstanding the existence of any other undertaking or security for any indebtedness of the Tenderer to the Owner and notwithstanding that any such security shall at the time when claim is made against the Bank or proceedings taken against the Bank hereunder, be outstanding or unrealized.
4. The amount stated by the Owner in any demand, claim or notice made with reference to this guarantee shall as between the Bank and the Owner for the purpose of these Presents be conclusive of the amount payable by the Bank to the Owner hereunder.
5. The liability of the Bank to the Owner under this Guarantee/Undertaking shall remain in full force and effect notwithstanding the existence of any difference or dispute between the Tenderer and the Owner, the Tenderer and the Bank and/or the Bank and the Owner or otherwise howsoever touching these Presents or the liability of the Tenderer to the Owner, and notwithstanding the existence of any instructions or purported instructions by the Tenderer or any other person to the Bank not to pay or for any cause withhold or defer payment to the Owner under these Presents, with the intent that notwithstanding the existing of such difference, dispute or instructions, the Bank shall be and remain liable to make payment to the Owner in terms thereof.
6. This Guarantee/Undertaking shall not be determined or affected by the liquidation or winding up or dissolution or change of constitution or insolvency of the Tenderer or any change in the legal constitution of the Bank or the Owner.
7. Without prejudice to any other mode of service, a demand or claim or other communication may be transmitted by the Owner to the Bank either by post or by fax. If transmitted by fax, the transmission shall be complete as soon as acknowledged by the Bank.
8. Notwithstanding anything contained herein:
 - i) The Bank's liability under this guarantee/undertaking shall not exceed (Amount in figures & words);
 - ii) The guarantee/undertaking shall remain in force upto _____ and any extension(s) thereof; and
 - iii) The Bank shall be released and discharged from all liability under this guarantee/undertaking unless a written claim or demand is issued to the Bank on or before _____ or the date of expiry of any extension(s) thereof if this guarantee/undertaking has been extended.



**PROCUREMENT OF VALVES FOR CONFIDENTIAL DEMO PLANT AT
MRPL, MANGALURU, KARNATAKA**

The Bank doth hereby declare that Shri_____ (designation)_____ who is authorised to sign this Guarantee/Undertaking on behalf of the Bank and to bind the Bank thereby.

This _____ day of _____ 20 _____.

Yours faithfully

Signature: _____

Name & Designation: _____

Name of the branch: _____



**PROCUREMENT OF VALVES FOR CONFIDENTIAL DEMO PLANT AT
MRPL, MANGALURU, KARNATAKA**

ANNEXURE – K TO ITB

CORPORATE GUARANTEE

This Corporate Guarantee made on this ___ day of _____ month _____ year by M/s _____ (Parent Company/Group Company/affiliate), a Company organized and existing under the laws of _____ and having its registered office at _____ (hereinafter referred to as the "Guarantor" which expression shall unless repugnant to the subject or context deemed to include their successors and assignees) at the request and/or behest of _____, a Company organized and existing under the laws of _____ having its registered office at _____ (hereinafter referred to as "Bidder"), in favour of Mangalore Refinery and Petrochemical Limited, a Public Company organized under the laws of India having its Registered office at _____ (hereinafter referred to as "Beneficiary").

Whereas:

The Beneficiary floated a public TENDER dated _____ no. _____ for _____ (Purpose). The Bidder has submitted its quotation dated _____ and has represented to the Beneficiary that the Bidder is the wholly owned subsidiary/Group Company/affiliate of the Guarantor and that the Bidder has access to and the Guarantor shall make available necessary financial and technical support as required by the Bidder for successful execution of the contract, if awarded to the Bidder, for the Purpose. Accordingly, the Guarantor is ready and willing to give this Corporate Guarantee on the terms and conditions hereinafter contained

We, the Guarantor are hereby recording the terms and conditions governing our obligations under this Guarantee with the intent of being legally bound by the same and hereby agree, covenant and bind ourselves as follows:-

1. The Guarantor hereby irrevocably and unconditionally guarantees to the Beneficiary, the performance by the Bidder of its obligations under the terms and conditions of the TENDER and the contract, upon the contract being awarded to them. The Guarantor shall execute such other deeds and documents as may be desired by the Beneficiary in this regard.
2. The Guarantor unconditionally and irrevocably guarantees to the Beneficiary that it will make available or cause to be made available to the Bidder all financial, technical support and expertise, expert manpower and procurement assistance and project management and other resources required to ensure that the Bidder can carry out its obligations as per the TENDER terms and conditions and that the Bidder at all times fully and effectively discharge its obligations under the terms and conditions of TENDER, including by discharging the obligations within the time and cost so stipulated.
3. The Guarantor hereby agrees that if the Bidder shall in any respect commit any breach or fails to fulfill any of the terms of the contract/TENDER or complete it in all respects or if there is a failure to make any supplies or if any material, equipment or machinery under the contract so supplied is not of the required specifications or does not perform as envisaged under the contract, then the Guarantor undertakes to forthwith perform the same and fulfill all the obligations required under TENDER/contract terms & conditions (including payment of any liquidated damages) on behalf of the Bidder without any extra cost and time implications. The decision of the Beneficiary with respect to breach/failure by the Bidder shall be final and binding on the Guarantor.



**PROCUREMENT OF VALVES FOR CONFIDENTIAL DEMO PLANT AT
MRPL, MANGALURU, KARNATAKA**

4. The Guarantor further undertakes to indemnify and keep harmless the Beneficiary against all losses, damages, expenses, claims, costs (including legal costs and attorney fees) which may be suffered or incurred or threatened to be suffered or incurred by the Beneficiary due to the failure or breach on the part of the Bidder under the contract and/or the Guarantor under this Guarantee.

5. The Guarantor assures and undertakes that during the term of the contract or of any guarantee for performance as per the contract, the Bidder shall continue to be the wholly owned subsidiary/affiliate/group company of the Guarantor and the Guarantor's liability shall not be affected due to any incapacity or lack of power or legal personality or change in the status of the Bidder or the Guarantor.

6. The Guarantor's liabilities under this Guarantee shall not exceed the maximum limit liability (if any) of the Bidder under the TENDER/contract terms and conditions.

7. The obligation of the Guarantor shall take effect from the date of this Guarantee and shall be independent of any other security given under the contract and remain in full force until all the obligations of the Bidder under the TENDER/contract have been fully performed and discharged and/or all sums of money payable to Beneficiary have been fully paid.

8. The liabilities of the Guarantor shall not be discharged, diminished or otherwise affected by:-

- (a) Any change in the Articles of Association or Bye-Laws or constitution of the Bidder or the Guarantor.
- (b) Any amendment to the contract (including any extension of time) or any waiver granted to the Bidder.
- (c) The dissolution, amalgamation, reconstruction or reorganization of the Bidder or the Guarantor.

9. NOTICE:

Any notice, demand, declaration or other communication to be given by the Beneficiary or the Guarantor to the other shall be in writing, in English language and delivered in person or by Air Mail or by Courier Services or by Facsimile or by E-Mail to the address given below and shall be deemed to be validly served after two days from the date thereof:-

For Guarantor
Attention of
Mailing Address
Email Address
Fax No.

For Beneficiary
Attention of
Mailing Address
Email Address
Fax No.

10. No modification, alteration or amendment of this Guarantee or any of its terms or provisions shall be valid or legally binding unless the Beneficiary consents to the same in writing.

11. No failure to take any action with respect to a breach of this Guarantee or a default by any other party shall constitute a waiver of the Beneficiary's right to enforce any provision of this Guarantee or to take action with respect to such breach or default or any subsequent breach or default.



**PROCUREMENT OF VALVES FOR CONFIDENTIAL DEMO PLANT AT
MRPL, MANGALURU, KARNATAKA**

12. The Guarantor confirms that it has all the necessary powers and corporate authority to issue this Guarantee in favour of the Beneficiary and this Guarantee constitutes a valid legal and enforceable document under the law to which it is subject. The undersigned has full power to issue this Guarantee under the power of Attorney /Resolution of Board of Directors Dated----- granted to him by the Guarantor.

13. GOVERNING LAW AND JURISDICTION:

This Guarantee shall be exclusively governed by and construed in accordance with the laws of India without giving effect to the principles of conflict of laws therein. No party shall take a plea that any forum is inconvenient.

14. DISPUTE RESOLUTION:

Any dispute arising out of or in relation to this Guarantee shall be resolved by arbitration as per the provision set out in the TENDER document.

IN WITNESS WHEREOF the Guarantor has duly executed this Guarantee as at the date first above written.

For and on behalf of Guarantor,

(Signature) Name:

Corporate Seal Designation:

Date:

Witness

Signature :



**PROCUREMENT OF VALVES FOR CONFIDENTIAL DEMO PLANT AT
MRPL, MANGALURU, KARNATAKA**

TENDER No: 3200000897

**TENDER FOR PROCUREMENT OF VALVES FOR
CONFIDENTIAL DEMO PLANT AT MRPL, MANGALURU,
KARNATAKA.**

SECTION-4

SPECIAL PURCHASE CONDITIONS (SPC)



**PROCUREMENT OF VALVES FOR CONFIDENTIAL DEMO PLANT AT
MRPL, MANGALURU, KARNATAKA**

INDEX

1.0	PAYMENT TERMS
2.0	EVALUATION CRITERIA FOR COMPARISON OF BIDS
3.0	COMMERCIAL LOADING OF OFFERS IN CASE OF DEVIATIONS
4.0	IMPORTS AND CUSTOMS DUTIES
5.0	INDIAN TAXES/DUTIES
6.0	FIRM PRICES
7.0	SUO-MOTO CHANGES IN PRICES
8.0	SPARES
9.0	CURRENCY OF BID
10.0	CONVERSION TO SINGLE CURRENCY
11.0	SINGLE POINT RESPONSIBILITY OF THE SUPPLIER
12.0	NEGOTIATION
13.0	ONE BID PER BIDDER
14.0	TRANSPORTATION
15.0	COMPREHENSIVE MARINE-CUM-ERECTION INSURANCE
16.0	GUARANTEE PERIOD
17.0	CONTRACT CUM PERFORMANCE BANK GUARANTEE (CPBG)
18.0	PRICE REDUCTION SCHEDULE (PRS)/ DELAYED DELIVERY
19.0	LIMITATION OF LIABILITY
20.0	TRANSFER OF PROPERTY FROM THE SELLER TO THE PURCHASER
21.0	INSPECTION
22.0	REPEAT ORDER
23.0	PART ORDER CONDITION
24.0	ORDER OF PRECEDENCE OF COMMERCIAL DOCUMENTS
25.0	CONDITIONS FOR MICRO & SMALL ENTERPRISES (MSE'S)
26.0	CONDITIONS FOR START UP COMPANIES
27.0	PURCHASE PREFERENCE LINKED WITH LOCAL CONTENT (PP-LC 2017) AND ANNEXURE-1
28.0	TERMS AND CONDITIONS FOR BIDDERS FROM A COUNTRY SHARING LAND BORDERS WITH INDIA
29.0	TERMS & CONDITIONS OF SUPERVISION OF ERECTION, TESTING & COMMISSIONING (IF APPLICABLE AS PER TECHNICAL SPECIFICATION)
30.0	TERMS & CONDITIONS OF POST WARRANTY COMPREHENSIVE ANNUAL MAINTENANCE CONTRACT (PWCAMC) (IF APPLICABLE AS PER TECHNICAL SPECIFICATION)



**PROCUREMENT OF VALVES FOR CONFIDENTIAL DEMO PLANT AT
MRPL, MANGALURU, KARNATAKA**

- 31.0** TERMS & CONDITIONS OF TRAINING OF EMPLOYER'S PERSONNEL AT MANUFACTURER'S WORKS/ FACILITIES (IF APPLICABLE AS PER TECHNICAL SPECIFICATION)
- 32.0** TERMS & CONDITIONS FOR SITE WORK (IF APPLICABLE AS PER TECHNICAL SPECIFICATION)
- 33.0** Procedure for Final Documentation (SPC-000009) (Rev.-01)
- 34.0** Vulnerability Atlas of India

ANNEXURE – A
ANNEXURE – B
ANNEXURE – C
ANNEXURE – D
ANNEXURE – E
ANNEXURE – F



**PROCUREMENT OF VALVES FOR CONFIDENTIAL DEMO PLANT AT
MRPL, MANGALURU, KARNATAKA**

1.0 PAYMENT TERMS

100% payment within 30 days against receipt of all material at site along with documents as indicated below.

- a. Commercial Invoice / Tax Invoice
- b. Third party Inspection Certificate / Inspection Release Note
- c. Test certificates (MTC / Chemical Analysis / Physical properties)
- d. Packing list
- e. Delivery challan
- f. Lorry Receipt / Bill of Coastal goods (as applicable)
- g. E-way bill (as applicable)
- h. Warranty Certificate / Guarantee Certificate

2.0 EVALUATION CRITERIA FOR COMPARISON OF BIDS:

2.1 Following costs, taxes, duties etc., as applicable, shall be used for evaluation of bids:

- Basic ex-works cost (including special tools and tackles),
- Cost of mandatory and commissioning spares,
- Packing & Forwarding charges,
- Third party inspection charges,
- FOB charges and taxes, duties in bidder's country (in case of foreign vendors),
- All taxes and duties applicable in India: Net of CenVAT amount shall be considered
- Port / Port handling charges (for foreign vendors)
- Freight / Transportation Charges (including inland freight / Transportation charges in case of foreign bidders upto site),
- Testing charges,
- Site work charges,
- Site supervision services charges (for number of days as informed in the Tender document),
- 3-D Modelling, Hazop Study, AMC charges, if applicable
- Training charges, if applicable
- Technical and commercial loadings, as defined in the Tender document.
- Any other charges indicated by the bidder

Suo moto price discounts and discounts for prompt payments shall not be used for evaluation.



**PROCUREMENT OF VALVES FOR CONFIDENTIAL DEMO PLANT AT
MRPL, MANGALURU, KARNATAKA**

Prices for Post Warranty Comprehensive Annual Maintenance Contract (PWCAMC), if any mentioned in Tender, shall be considered for evaluation. However, Purchase order for PWCAMC shall be placed separately by MRPL.

Evaluation shall take into consideration Government of India guideline with respect to Purchase Preference applicable to Central PSUs, Micro and Small Enterprises (MSEs) as well as any applicable Government of India Guidelines.

Ministry of Micro, Small and Medium Enterprises, Government of India have notified the public procurement policy (PPP), 2012 for facilitating promotion and development of Micro and Small Enterprises, which shall be complied with for evaluation and ordering.

Ministry of Petroleum and Natural Gas, Government of India has notified the policy to provide Purchase preference (linked with local content) (PP-LC) to the manufacturers / service providers having the capability of meeting / exceeding the local content targets in Oil and Gas business activities, which shall be complied with for evaluation and ordering in applicable cases.

Third party Inspection charges for applicable equipment / materials / goods shall be excluded from supplier (s) quoted prices, Consultant shall arrange TPI from anyone of the following approved Third Party Inspection Agencies for the Projects:

- i. Certification Engineers International Ltd. (CEIL)
- ii. Lloyds Register of Industrial Services (LRIS)
- iii. Det Norske Veritas (DNV)
- iv. Bureau Veritas (BV)
- v. TUV

In case of Tie between two or more bidders at L-1 Position, all the L-1 bidders shall be asked to submit discount over previous quoted rate on NIC e-tendering Portal.

The process shall be repeated till final L-1 position is established.

2.2 Where only Indian Bids are under comparison

- 2.2.1 Bids shall be evaluated on the basis of landed cost at Site, including site work, if any, all duties, taxes, transportation charges.
- 2.2.2 Cost of mandatory spares, if identified in the Material Requisition, commissioning spares and special tools & tackles will be included for price evaluation of bids, but cost of Spares for two years operation shall be excluded.
- 2.2.3 Commercial Loading shall be done on FOT dispatch point price.
- 2.2.4 Technical loading, if any, shall be considered for evaluation of bids.
- 2.2.5 3-D Modelling, Hazop Study, AMC charges shall be considered for evaluation wherever 3-D Modelling, Hazop Study and AMC is required.
- 2.2.6 Supervision (man days as indicated in Technical Specification as well as TBA) and Training charges shall be considered for evaluation wherever supervision and training are required



**PROCUREMENT OF VALVES FOR CONFIDENTIAL DEMO PLANT AT
MRPL, MANGALURU, KARNATAKA**

3.0 COMMERCIAL LOADING OF OFFERS IN CASE OF DEVIATIONS

3.1 BASIS OF LOADING

Indian Bids shall be loaded on FOT Despatch Point prices.

3.2 PAYMENT TERMS

Any differential payment terms offered by an Indian supplier as against the terms specified in the Tender/ GPC shall be loaded at 12% (simple interest) for the applicable period as under:

Drawing approval : 80% of the delivery period

Sub-ordering of raw materials : 75% of the delivery period

Receipt of raw material at vendor's works : 50% of the delivery period

Final 10% also against dispatch documents: one month

Period of any other stage shall be suitably decided at the time of evaluation.

Advance along with LOA/ PO will not be allowed. If a supplier insists for advance payment along with LOA/PO, his offer shall be liable for rejection.

3.3 CONTRACT CUM PERFORMANCE BANK GUARANTEE (CPBG)-Not Applicable

Performance Bank Guarantee shall be required in all cases of supplies of value above Rs 10 Lakhs. In case a supplier offers to give a PBG for less than 5% of order value than what is provided in GPC/SPC, loading shall be done for the differential amount:

3.4 DELAYED DELIVERIES (CONSIDERING GPC CLAUSE OF 0.5% DELAYED ~ 5% TOTAL) – Not Applicable

In case a Supplier does not accept the delayed delivery clause and/or takes any deviation (including indicating penalty clause/Liquidated Damages in place of Price Reduction Schedule Clause) or takes exception to the percentage rate mentioned in GPC, the offer of such supplier(s) shall be loaded as under:

For Bulk Items

0.5% UDOV to 5%TOV : No loading

0.5% UDOV to 5% UDOV : 5%

0.5% UDOV to less than 5% TOV : Differential between the Offered % and 5%

Any other deviation/indicating Liquidated damages/indicating penalty or non-acceptance of price reduction schedule clause : 5%

For All Items Other than Bulk

0.5% TOV to 5%TOV : No loading

0.5% UDOV to 5% TOV : 5%

0.5% TOV to less than 5% TOV : Differential between the



**PROCUREMENT OF VALVES FOR CONFIDENTIAL DEMO PLANT AT
MRPL, MANGALURU, KARNATAKA**

~~Offered % and 5%~~

~~Any other deviation/indicating Liquidated
damages/indicating penalty or non-acceptance
of price reduction schedule clause : 5%~~

~~UDOV – Undelivered Order Value~~

~~TOV – Total Order Value~~

3.5 FREIGHT CHARGES:

- 3.5.1 During techno-commercial evaluation, if it is found that bidder have not quoted the freight charges or any other charges required to be quoted extra in the bid as per price schedule and forming the part of bid evaluation, bidder shall be asked to absorb these charges. If the bidder do not agrees for inclusion, bid of such bidder shall be liable for rejection.
- 3.5.2 Further, in case a bidder during techno-commercial evaluation confirms that they have quoted the freight charges or any other charges (forming the part of evaluation) in the priced bid, however after priced bid opening, it is found that these charges are not quoted in priced bid, then such charges shall be deemed to be included in the quoted prices. Evaluation & Ordering shall be carried out including these charges in quoted prices. No confirmation from the bidder shall be obtained on this aspect

3.6 INDIAN TAXES/DUTIES:

- 3.6.1 Taxes and duties will be loaded as quoted by the bidder. However, if a BIDDER states that taxes/duties are not applicable at present and will be charged as applicable at the time of delivery then his bid shall be loaded by the maximum rate of taxes/duties applicable at the time of evaluation of Bids.
- 3.7 Cost loading in respect of utilities etc. will be considered as per respective Technical specificatin stipulation.

4.0 IMPORTS AND CUSTOMS DUTIES

4.1 Import Duties, i.e., Basic Customs Duty, GST & Social Welfare Surcharge on imported materials

- 4.1.1 MRPL shall import all Capital Goods considering Merit rate of custom duty.

4.2 Direct imported supplies by Foreign suppliers

- 4.2.1 For imported materials sold & supplied directly by foreign suppliers to MRPL and consigned to MRPL, Import Duties, i.e., Basic Customs Duty, Social Welfare Surcharge, IGST applicable in India shall be directly paid by MRPL to tax authority.
- 4.2.2 The vendor must ascertain and confirm along with supporting documents in the bid,if any Customs Duty exemption / waiver is applicable to the products being supplied by him under any multi-lateral / bi-lateral trade agreement between India and bidder's country.
- 4.2.3 The bidder shall be liable to provide all documentation to ensure availment of the exemption / waiver. In case the bidder defaults on this due to any reason, whatsoever, he shall be liable to



**PROCUREMENT OF VALVES FOR CONFIDENTIAL DEMO PLANT AT
MRPL, MANGALURU, KARNATAKA**

bear the incremental Customs Duty applicable, if any.

- 4.2.4 Any Customs Duty applicability on account of any change in the bi-lateral / multilateral agreement shall be to bidder's account.
- 4.2.5 Documentation to be furnished for availing the exemption / waiver of customs duty shall be specifically listed in the Letter of Credit also as the pre-requisite for release of payment against shipping documents and this documentation shall necessarily form part of shipping documents.
- 4.2.6 Any additional levies/duties on Imports (viz. Anti-Dumping Duty, Safeguard Duty, etc.) as notified by Govt of India from time to time shall also be considered for evaluation.

4.3 Imported supplies by Indian suppliers as built-in import content

- 4.3.1 Quoted prices are inclusive of Basic Customs Duty, Social Welfare Surcharge, after considering the benefit of Input Tax Credit on GST portion (if applicable).
- 4.3.2 Supplier shall be responsible for the timely payment of the customs duties to the relevant Government Authorities
- 4.3.3 All harbour dues, pilotage fees, port fees, wharf fees, unloading costs incurred in India in respect of any imported goods shall be to supplier's account.
- 4.3.4 Prices shall be firm on account of variation in foreign exchange rate.
- 4.3.5 Prices for such import content shall also include any additional levies/duties on Imports (viz. Anti-Dumping Duty, Safeguard Duty, etc.) as notified by Govt of India from time to time, as applicable.
- 4.3.6 Owner shall not provide any import licence.
- 4.3.7 Prices shall be firm on account of any variation in Custom Duties.

4.4 Supplies of Imported finished goods directly supplied to site by Indian Supplier:

- 4.4.1 GST on imported capital goods sold & supplied to MRPL and consigned to MRPL against which Input Tax Credit shall be available to MRPL shall not be included in the quoted prices and shall not be considered for evaluation. Quoted prices shall be inclusive of Basic Customs Duty only.
- 4.4.2 The supplier shall provide MRPL with all documents necessary for MRPL to claim CENVAT benefit ((if applicable) on the GST paid on the imported materials covered by the Supplies, including but not limited to CENVAT Bill of Entry

5.0 INDIAN TAXES/ DUTIES

5.1 Goods and Services Tax (GST)

- 5.1.1 The price quoted in the TENDER shall be inclusive of all Taxes/duties/Cess/levies/fees etc except "Goods and Services Tax" (hereinafter called GST) (i.e. IGST or CGST and SGST/UTGST) as levied with respect to Contractors' scope of work/ scope of Supply, till the completion of the work and shall be born and paid by the contractor.
- 5.1.2 Applicable IGST/CGST/SGST as quoted shall be considered for evaluation as MRPL is not eligible for any setoff on account of Input Tax Credit.
- 5.1.3 Contractor/vendor shall be required to issue tax invoice in accordance with GST Rules so that input credit (if applicable) can be availed by CLIENT. In the event that the contractor / vendor fails to provide the invoice in the form and manner prescribed under the GST Act read with GST Invoicing Rules thereunder, CONSULTANT/ CLIENT shall not be liable to make any payment against such invoice.
- 5.1.4 Contractor/vendor shall forthwith upload the appropriate document at GSTN portal complying with all GST regulations including but not limited to payment of GST by contractor / vendor.



**PROCUREMENT OF VALVES FOR CONFIDENTIAL DEMO PLANT AT
MRPL, MANGALURU, KARNATAKA**

In case of non-receipt of tax invoice or nonpayment of GST by the contractor/vendor, CONSULTANT/ CLIENT shall withhold the payment.

- 5.1.5 GST payable under reverse charge, if any, shall not be paid to the contractor/vendor. If the same has already been reimbursed / paid to the Contractor for any reason whatsoever, the said amount shall be deducted / recovered / adjusted from the payment due to the Contractor.
- 5.1.6 Notwithstanding anything contained anywhere in the Agreement, in the event that the input tax credit (if applicable) of the GST charged by the Contractor / Vendor is denied by the tax authorities to CLIENT due to reasons attributable to Contractor/Vendor. CONSULTANT/ CLIENT shall be entitled to recover such amount from the Contractor / Vendor by way of adjustment from the next invoice or from Bank Guarantee. In addition to the amount of GST, CONSULTANT/ CLIENT shall also be entitled to recover interest and/or penalty, as the case may be, imposed by the tax authorities on CONSULTANT/ CLIENT.
- 5.1.7 TDS under GST, if applicable, shall be made from contractor's/vendor's bill at applicable rate and a certificate as per rules for tax so deducted shall be provided to the contractor/vendor.
- 5.1.8 No variation on account of taxes and duties, statutory or otherwise, shall be payable by CLIENT to contractor/vendor except for GST. However, any statutory variation for GST shall be payable up to date of completion against documentary evidence. Any reduction in Taxes / duties / cess / levies / fees shall be passed on to CLIENT.
- 5.1.9 Any new taxes / duties / cess / levies / fees notified or imposed after the submission of last / final price bid but before the date of completion of work shall be to CLIENT's Account.

5.2 Income Tax

5.2.1 Foreign (Expatriate) Supervisors

The supervision/ site work charges of foreign vendor shall be gross of income tax, i.e., inclusive of Income Tax at the applicable prevailing rate as per Indian Income Tax rules. Owner/Purchaser shall deduct at source the tax by Purchaser while making payments against each invoice for the services in India. Certificate for Tax Deducted at Source (TDS) shall be provided to the Supplier.

5.2.2 For Indian (Resident) supervisors

Supervision/ site work charges of Indian vendor shall be inclusive of income tax.

Tax shall be deducted at source by MRPL from all sums due to an Indian tax resident bidder in accordance with the provisions of the Income Tax Act, 1961, as in force at the relevant point of time.

MRPL shall issue a Tax deduction or withholding certificate to the bidder evidencing the Tax deducted or withheld and deposited by MRPL on payments made to the supplier to enable the bidder to claim the credit of the Tax deducted or withheld by MRPL.

5.3 General

- 5.3.1 In case GST is stated as not applicable on freight charges presently, and if they are applicable at the time of delivery due to any reasons other than statutory, the same will be borne by the Supplier.
- 5.3.2 The benefit of any Tax exemption, concessions, rebate or any other incentives available when the Supplier or its Sub supplier/ vendor are performing their obligations under the Purchase Order, shall be passed on to MRPL.



**PROCUREMENT OF VALVES FOR CONFIDENTIAL DEMO PLANT AT
MRPL, MANGALURU, KARNATAKA**

- 5.3.3 Any error of interpretation of applicability of taxes/ duties by the supplier shall be to supplier's account.
- 5.3.4 The classification of goods as per GST act should be correctly done by the supplier to ensure that Input Tax Credit benefit (if applicable) is not lost to MRPL on account of any error on the part of the supplier.
- 5.3.5 Bidder to ensure that the benefit of a reduction in the tax rate or the input tax credit availed by any registered taxable person has resulted in commensurate reduction in the price of goods/service supplied by such person. Failure on the part of bidder to ensure the same shall attract the provision of Anti Profiteering as notified by the Govt of India.
- 5.3.6 Bids shall be evaluated as per GST Rate quoted by bidders. Any changes to GST rate (due to wrong assessment of HSN code or any other reason not-attributable to MRPL/CONSULTANT) during the bidding stage shall be to the account of the Supplier. In case the GST rate invoiced at the time of supply is lower than that indicated during the bidding stage, the supplier shall be paid based on the invoices submitted at the lower rates. However, in case the GST rate invoiced at the time of supply is higher than that indicated during the bidding stage, MRPL shall pay only the rate indicated during the bidding stage and the remaining tax amount shall be to the Supplier's account

6.0 FIRM PRICES

- 6.1 The prices shall be firm and fixed and not subject to any variation, whatsoever.
- 6.2 For 2 years O&M spares, prices shall be kept valid for a period of 1 year from the date of order of main equipment.

7.0 SUO-MOTO CHANGES IN PRICES

- 7.1 Any unsolicited reduction in price offered by a bidder within the bid validity by way of discount or revised prices, subsequent to the bid due date, shall not be taken into account. However, such reduction in price shall be taken into account for ordering if such bidder happens to be recommended as per the originally quoted prices.
- 7.2 In the event of any unsolicited price increase sought by any bidder, subsequent to the bid due date, the bid of such a bidder shall be liable to be rejected. However, in case the unsolicited price increase is known only after price bid opening and the bidder's comparative ranking changes by withdrawal of the price increase, the bidder shall not be allowed to withdraw the price increase and the bid shall be rejected outright. But, if such a bidder is lowest with or without the price increase, the order shall not be placed with price increase and if the bidder does not agree, the enquiry shall be refloat.

Wherever, decision is taken to reject a bid.

8.0 SPARES

- 8.1 TENDER document/Technical Specification shall include list of mandatory spares, wherever required, clearly indicating quantity required. All such spares shall be included in the prices quoted by the bidder. The commissioning spares and special tools and tackles, if applicable, shall, also, be included by the bidder in his quoted prices. However, Bidder shall be fully responsible and no additional cost shall be paid in case mandatory / commissioning spares / special tools & tackles over & above those considered by bidder are required.
- 8.2 Bidders will be required to quote for their recommended two years operation and maintenance spares (with a price validity of 01 year from the date of award of main



**PROCUREMENT OF VALVES FOR CONFIDENTIAL DEMO PLANT AT
MRPL, MANGALURU, KARNATAKA**

equipment). But the same will not be considered for Price Evaluation.

9.0 CURRENCY OF BID

9.1 Indigenous SUPPLIERS are required to submit price in **Indian Rupees only**.

10.0 CONVERSION TO SINGLE CURRENCY

10.1 To facilitate evaluation, the Owner will convert Foreign bidders' bid considering RBI reference rate of quoted currency on the day of price bid opening. In case the rate is not available as on the day of price bid opening, the latest available rate prior to the day of price bid opening, shall be considered.

11.0 SINGLE POINT RESPONSIBILITY OF THE SUPPLIER

In case of TENDER containing supplies as well as site work/ services, a single order, covering the supply part as well site work/ services, shall be placed. Separate Orders for supply and site work may be considered on case to case basis.

12.0 NEGOTIATION

12.1 Negotiations will not be conducted with the bidders as a matter of routine. However, MRPL reserves the right to conduct negotiations.

13.0 ONE BID PER BIDDER

13.1 A Bidder shall submit only one bid in the same bidding process. A Bidder who submits or participates in more than one bid will cause all the proposals in which the bidder has participated to be disqualified.

13.2 Alternative price bids are not acceptable.

14.0 TRANSPORTATION

14.1 INDIGENOUS SUPPLIERS

14.1.1 Indigenous SUPPLIERS are required to dispatch the goods on door delivery basis through any of IBA Approved Transporters.

15.0 COMPREHENSIVE MARINE-CUM-ERECTION INSURANCE

Owner shall arrange comprehensive Marine Cum Erection insurance policy, Therefore insurance shall be excluded from the bidder's scope. However, in cases involving site works, bidder shall arrange for insurance of their tools & tackles, workmen compensation insurance and third party insurance

16.0 GUARANTEE PERIOD

The performance guarantee clause no 29 of GPC (Indigenous) & clause 27 of GPC (Imported) stands modified as below:

16.1 "The Seller shall guarantee that any and all materials used in execution of the Purchase Order shall be in strict compliance with characteristics, requirements and specifications and that the same shall be free from any defects. Checking of the Seller's drawings by the



**PROCUREMENT OF VALVES FOR CONFIDENTIAL DEMO PLANT AT
MRPL, MANGALURU, KARNATAKA**

Purchaser/Purchaser's representatives and their approval and permission to ship or despatch the equipment and materials granted by Inspectors shall not relieve the Seller from any part of his/its responsibilities of proper fulfilment of the requirements.

16.2 The Seller will guarantee that all materials and equipment's shall be repaired or replaced as the case may be, at his own expense, in case the same have been found to be defective in respect of material, workmanship or smooth and rated operation within a period 15 months after the equipment/ material have been put in service or 30 months from the date of shipment, whichever is earlier. Repaired or replaced equipment/ materials shall be similarly guaranteed by the SELLER for a period of fifteen (15) months from the date of replacement/ repair subject to a maximum of 30 months from the date, the main equipment/ material have been put in service. All expenses for such replacement/ repair of equipment/ material shall be to the account of the Seller including freight, if any.

16.3 Acceptance by the Purchaser or its Inspectors of any equipment and materials or its replacement will not relieve the Seller of its responsibility of supplying the equipment/materials strictly according to the specification and according to the guarantees agreed by the Seller".

17.0 CONTRACT CUM PERFORMANCE BANK GUARANTEE (CPBG)-Not Applicable

17.1 Within 30 days from the date of issue of Purchase Order, the Seller shall furnish Contracts cum performance guarantee in the form of Bank Guarantee as per the purchaser's proforma for an amount equivalent to 5% of the order value.

17.2 The proceeds of the CPBG shall be appropriated by the Purchaser as compensation for any loss resulting from the Seller's failure to complete his obligations under the Contract without prejudice to any of the rights or remedies the PURCHASER may be entitled to as per terms and conditions of CONTRACT.

17.3 This CPBG shall also govern the successful performance of Goods and Services during the entire period of Contractual Warrantee/Guarantee.

17.4 The CPBG shall be denominated in the currency of the CONTRACT.

17.5 The Contracts cum Performance Guarantee shall be valid for the duration of 2 months beyond the expiry of Warrantee/Guarantee period. The Bank Guarantee will be discharged by PURCHASER not later than 2 months from the date of expiration of the Seller's entire obligations, including any warrantee obligations, under the CONTRACT.

17.6 CPBG shall not be required for orders up to Rs.10 (Ten) Lakhs

17.7 Bank Guarantee(s) shall be issued through Indian Nationalized Bank/ Indian Scheduled bank (other than Co-operative Banks) / Indian branches of foreign banks registered with Reserve Bank of India as a scheduled foreign bank.

17.8 It will be the responsibility of the Seller to keep the Bank Guarantee fully subscribed. Any shortfall in the value of the Bank Guarantee as a result of Order Amendment due to change in order value / encashment by the Purchaser either in full or in part in terms of Seller's Performance shall be replenished by the Seller within two weeks thereof.

18.0 PRICE REDUCTION SCHEDULE (PRS) / DELAYED DELIVERY- Not Applicable

The Delayed Delivery clause no 18 of GPC (Indigenous) & Clause 17 of GPC stands modified as below:



**PROCUREMENT OF VALVES FOR CONFIDENTIAL DEMO PLANT AT
MRPL, MANGALURU, KARNATAKA**

- 18.1 The time and date of delivery of materials/ equipment / site work as stipulated in the Purchase Order shall be deemed to be the essence of the agreement. For any delay in delivery of equipment / materials / site work or part thereof beyond the delivery date stipulated, the Purchaser may:
- a) FOR BULK ITEMS: Accept delayed delivery at prices reduced by a sum equivalent to one half of one percent (1/2%) of the total value of delayed item/quantity for every week of delay or part thereof, limited to a maximum of five percent (5%) of the total order value.
- b) ~~FOR ITEMS OTHER THAN BULK ITEMS (WITH OR WITHOUT SITE WORK):~~
~~Accept delayed delivery at prices reduced by a sum equivalent to one half of one percent (1/2%) of the total order value for every week of delay or part thereof, limited to a maximum of five percent (5%) of the total order value.~~

- 18.2 Wherever the supply period and site work are indicated as two separate periods and notice of site readiness is required for site work, intervening period, if any, shall be excluded, while calculating the price reduction for delay.

In respect of orders involving supervision of installation & commissioning, PRS shall not be levied on supervision charges, irrespective of the delay in supplies.

Note: It shall be endeavor to split the period i.e. a separate period for supply and site work.

- 18.3 Price reduction shall be effected in the Invoice value before presenting for payment. The Purchaser reserves the right to cancel the Purchase Order for any delay exceeding the period of maximum reduction and the Seller shall be liable to all consequences thereof.
- 18.4 For the purpose of PRS, part of the week shall be considered as one week. Further, total order value means total order value (Supplies + Site Work, if applicable) on completion of supplies (including any amendments/ change order) / site work, if applicable, excluding cases of Short Closure/ cancellation.

19.0 LIMITATION OF LIABILITY

Notwithstanding anything contrary contained herein, the aggregate total liability of Supplier, excluding his liability towards infringement of patent, trade mark or industrial design rights, under the contract or otherwise shall be limited to 100% of Total Order value of Purchase order. However, neither party shall be liable to the other party for any indirect and consequential damages, loss of profits or loss of production.

20.0 TRANSFER OF PROPERTY FROM THE SELLER TO THE PURCHASER

The clause no 21 of GPC (Indigenous) "Transfer of Property from the Vendor to the Owner", stands modified as below:

- 20.1 The transfer of property shall be deemed to have taken place as follows subject to the provisions herein contained:

FOB/FCA/CFR Contracts: In the case of FOB/FCA, CFR & CIF Contracts, when the Goods have been put on board of ship, at the specified port of loading and a clean Bill of Lading / Airway Bill is obtained.



**PROCUREMENT OF VALVES FOR CONFIDENTIAL DEMO PLANT AT
MRPL, MANGALURU, KARNATAKA**

F.O.T. despatch point: On handing over the equipment to the carrier against receipt and such receipt having been passed over to the Purchaser.

F.O.T. Project Site: on receipt of material at Project site.

Equipment sent freight/ carriage paid to the Refinery site: On receipt of goods at site.

Equipment erected by the Seller: on acceptance at job site.

Equipment commissioned by the Seller: On taking over by the Purchaser for regular operation after test run at maximum capacity for specified period satisfactorily performed.

21.0 INSPECTION

Indigenous sourced material shall be inspected by TPIA out of BV/DNC/TRV/CEIL/LRS as mentioned in the TENDER. TPIA charges for the same are included in Bidders quoted prices and TPI shall be arranged by Bidder. Bidder shall ensure all test applicable as per attached QAP. Also following shall be specified:

- i) QAP will be approved by Inspection agency / MRPL incorporating requirements of Inspection and Test Plan, Technical specifications provided with Purchase Order / Contract document.
- ii) The Inspection release note issued by the Third Party Inspection agency shall clearly stipulate that materials/equipment have been inspected as per Code-1 approved drawings and approved QAP.
- iii) Certification of final documents, wherever applicable, for release of final payment, shall be carried out by Inspection Authority issuing the final inspection certificate

22.0 REPEAT ORDER: (APPLICABLE)

Repeat orders on same unit prices, terms & conditions will be applicable within a period of 6 months from the date of Purchase Order, provided the following conditions are met.

- a) The original order was placed on competitive basis.
- b) The prices have not shown any downward trend.
- c) The Order value & Quantity limited to 100% of the original order.

23.0 PART ORDER CONDITION: (NOT APPLICABLE)

23.1 Bidder hereby agrees to accept part order at Purchasers option without any limitation whatsoever.

23.2 Any charges quoted extra as lumpsum shall be applicable prorata on value basis in the event of part order.

24.0 ORDER OF PRECEDENCE OF COMMERCIAL DOCUMENTS

In case of an irreconcilable conflict between NIT, Special Purchase Conditions & General Purchase Conditions (GPC), the following shall prevail to the extent of such irreconcilable conflict in order of precedence:

- i) Notice Inviting Tender (NIT)



**PROCUREMENT OF VALVES FOR CONFIDENTIAL DEMO PLANT AT
MRPL, MANGALURU, KARNATAKA**

- ii) Instructions to Bidders (ITB)
- iii) Special Purchase Conditions (SPC)
- iv) General Purchase Conditions (GPC)

25.0 CONDITIONS FOR MICRO AND SMALL ENTERPRISES (MSEs)

- 1) As per Public Procurement policy (PPP) for Micro & Small Enterprises (MSEs) Order, 2012 issued vide Gazette Notification dated 23.03.2012 by Ministry of Micro, Small and Medium Enterprises of Govt. of India, MSEs must be registered with any of the following in order to avail the benefits / preference available vide Public Procurement Policy MSEs Order, 2012.
 - a) District Industries Centers (DIC)
 - b) Khadi and Village Industries Commission (KVIC)
 - c) Khadi and Village Industries Board
 - d) Coir Board
 - e) National Small Industries Corporation (NSIC)
 - f) Directorate of Handicraft and Handloom
 - g) Any other body specified by Ministry of MSME (MoMSME)
 - h) UdyogAadhaar Acknowledgment / UdyogAadhaar Memorandum issued by MoMSME.
 - i) Udyam Registration Portal

MSEs participating in the tenders must submit valid & authorized copy of certificate of registration with any one of the above agencies. In case of bidders submitting DIC registration certificate, he shall attach original notarized copy of the DIC certificate.

- 2) The MSEs registered with above mentioned agencies /bodies are exempted from EMD.
- 3) The definition for Micro & Small Enterprise shall be as per the guidelines issued by Ministry of MSME vide Gazette notification no. 1702(E) dated 01.06.2020 and 2119(E) dated 26.06.2020 which came into effect from 01.07.2020.
- 4) To be classified as Micro or Small Enterprises as per new definition, The companies need to register themselves on "Udyam Registration Portal" on or after 01.07.2020. This provision is for new establishments as well as for existing MSE companies registered with NSIC, UAM etc.
- 5) The existing MSE companies registered prior to 30.06.2020 shall continue to be valid only for a period up to 31.03.2021.
- 6) Bidder shall be Manufacturer for supply items
As per the MoMSME, the benefits of the PP Policy extended only to manufacturers registered under this and are not applicable to traders/ dealers/resellers/ distributors/authorized agents etc. Accordingly, the eligible MSE bidders shall be registered for the item tendered.

Bidder shall submit proof that he is a manufacturer of the item for which he is quoting and he shall highlight the details of his manufacturing status in the MSE certificate against the item he is proposing to bid in the tender. However, in cases where installation / commissioning and related activities along with Purchase of item(s) is/are involved and the bidder has relevant MSE certification, then he shall be eligible for claiming benefits of the



**PROCUREMENT OF VALVES FOR CONFIDENTIAL DEMO PLANT AT
MRPL, MANGALURU, KARNATAKA**

PP Policy.

- 7) The registration certificate issued must be valid as on Bid closing date of the tender. Bidder shall ensure validity of registration certificate in case bid closing date is extended.
- 8) The MSEs who have applied for registration or renewal of registration with any of the above agencies/bodies, but have not obtained the valid certificate as on close date of the tender, are not eligible to avail benefits under PP Policy. Where validity of such certificates such as NSIC certificate has lapsed, it shall be the responsibility of the bidder to seek renewal from the concerned Govt agency before such expiry. Documentary evidence seeking extension before the lapse of validity of such certificate and an authorization letter from the Govt agency having received application for renewal shall be submitted before the bid closing date.
- 9) MRPL being a critical refinery installation, vital to public safety and maintaining essential supplies to the society and other customers including Govt agencies, reserves right to grant relaxation in tender conditions under the Public Procurement Policy on procurement of goods and services from Micro and Small Enterprises (MSEs) order 2012/other Government guidelines as applicable from time to time.

10) PURCHASE PREFERENCE:

- a) Items which are reserved for exclusive purchase from Micro and Small Enterprises shall be procured from Micro and Small Enterprises as per Public Procurement Policy.
- b) Subject to meeting terms and conditions stated in the tender document, **twenty five** percent of the total quantity of the tender is earmarked for MSEs registered with above mentioned agencies/bodies for the tendered item/services.
- c) In case MSE bidder is L1 entire value of the tender is to be ordered on the L1 MSE bidder.
- d) In tender, participating Micro and Small Enterprises quoting price within price band of L1 + 15% shall also be allowed to supply a portion of requirement by bringing down their price to L1 price in a situation where L1 price is from someone other than a Micro and Small Enterprise and such Micro and Small Enterprise shall be allowed to supply upto **25 percent** of the total tendered value (where the tender quantity can be split).
- e) In case of more than one such MSEs are in the price band of L1 + 15% and matches the L1 price, the supply may be shared proportionately if the job can be split.
- f) In case the tendered quantity cannot be split, MSE shall be allowed to supply total tendered quantity provided their quoted price is within a price band of L1 + 15 percent and they match the L1 price.



**PROCUREMENT OF VALVES FOR CONFIDENTIAL DEMO PLANT AT
MRPL, MANGALURU, KARNATAKA**

- g) If the quantity cannot be split and there are more than one eligible MSE bidders (price band within L1+15%) then the opportunity to match the L1 rate of the tender shall be given first to MSE (who have quoted lowest rate among the MSEs within the price band of L1+15%) and the total quantity shall be awarded to him after matching the L1 price of the tender.
- h) If the MSE who have quoted lowest rate among the MSEs in the price band of L1 + 15% do not agree to match the rate of L1 of the tender, then the next ranked MSE bidder who has quoted within the price band of L1 + 15% in order shall be given chance to match the rate of L1 for award of the quantity/order.
- i) For more clarity in this regard, following table is furnished;

Type of Tender	Price quoted by MSE	Finalization of tender
Can be Split	L1	Full order on MSE
Can be Split	Not L1 but within L1+15%	25% order on MSE subject to matching L1 price
Cannot be Split	L1	Full Order on MSE
Cannot be Split	Not L1 but within L1+15%	Full Order on MSE subject to matching L1 price

- j) In case where the tender quantity can be split and MSE vendor is already getting order for more than 25% of the tendered quantity / value, no additional purchase preference is required to be given in the tender.
- k) In case MSE vendor is already getting order less than 25% of the tendered quantity / value, purchase preference to this and other vendors (together) shall be given only up to the differential quantity to make total as 25% to MSE vendor.
- l) In case where quantity against a line item cannot be split (i.e., minimum 25% to MSEs) or items with single quantity or in grouped item, the complete line item/group shall be awarded on MSE bidder within the price range of L1 bidder's evaluated price + 15% subject to their matching L1 bidder's price.
- m) The purchase preference to MSE is not applicable for works contracts where supply of goods not produced by MSEs is also involved.
- 11) Out of the **twenty five** percent target of annual procurement from micro and small enterprises **four percent** shall be earmarked for procurement from micro and small enterprises owner by Scheduled Caste & Scheduled Tribe entrepreneurs. In the event of failure of such MSEs to participate in the tender process or meet the tender requirements and L1 price five percent sub-target so earmarked shall be met from other MSEs.



**PROCUREMENT OF VALVES FOR CONFIDENTIAL DEMO PLANT AT
MRPL, MANGALURU, KARNATAKA**

- 12) Special provision for Micro and Small Enterprise owned by women. Out of the total annual procurement from Micro and Small Enterprises (MSEs), 3% from within the 25% target shall be earmarked for procurement from MSEs owned by women.
- 13) To qualify for entitlement as SC/ST owned MSE, the SC/ST certificate issued by District Authority in addition to certificate of registration with any one of the agencies mentioned in paragraph (1) above. Alternatively, the bidder shall be responsible to furnish necessary documentary evidence for enabling MRPL to ascertain that the MSE is owned by SC/ST/Women entrepreneurs. MSE owned by SC/ST/Women is defined as:
- a) In case of proprietary MSE, proprietor(s) shall be SC/ST/Women
 - b) In case of partnership MSE, The SC/ST/Women partners shall be holding at least 51% shares in the enterprise.
 - c) In case of Private Limited Companies, at least 51% share shall be held by SC/ST/Women promoters.
- 14) If the bidder does not provide appropriate document or any evidence to substantiate the above, then it will be presumed that he does not qualify for any preference admissible under the Public Procurement Policy, 2012.
- 15) **TReDS:** TReDS is an electronic institutional mechanism for facilitating the financing of trade receivables of MSMEs through multiple financiers. MRPL is already registered on the following TReDS platform:
- M/s Receivable Exchange of India (RXIL), Mumbai,
 - M/s Mynd Solutions Private Limited (Mynd), New Delhi
 - M/s A TREDS (Invoicemart), Mumbai

MSE vendors are required to register on the TReDS platform. The MSME vendors can avail the TReDS facility, if they want to.

Declaration Form for availing purchase preference

Sr.no	Paramter	Declaration	Remarks
1	Whether bidder is an MSE bidder?	Yes/ No	If Yes – Necessary documents to be attached with unpriced part of the bid
2	Whether bidder wants avail purchase preference under Public Procurement Policy-2012?(PPP-2012)	Yes/ No	If Yes- Bidder will not be entitled for Purchase Preference Linked with Local Content-2017. (PP-LC 2017)



**PROCUREMENT OF VALVES FOR CONFIDENTIAL DEMO PLANT AT
MRPL, MANGALURU, KARNATAKA**

3	Whether bidder wants avail Purchase Preference Linked with Local Content-2017? (PP-LC 2017)	Yes/ No	If Yes- 1. Bidder will not be entitled for purchase preference under Public procurement Policy 2012? (PPP-2012) 2. Bidder shall furnish the percentage of Local content with declaration that the percentage of Local content is calculated as per the calculation methodology given herewith. 3. The minimum requirement of Local content is 22% to avail Purchase Preference Linked with Local Content Policy-2017.
---	---	---------	--

Note:

While evaluating the bids, for price matching opportunities and distribution of quantities among bidders, the order of precedence shall be as under:

1. MSE bidder (PPLC-2012)
2. PP-LC complied bidder (PP-LC)

The bidder claiming the PP-LC benefit shall be required to furnish an undertaking on bidder's latter head confirming his meeting the Local Content and this undertaking shall be certified as under:

- Where the total quoted value is less than INR 5 Crore.
The LC content shall be self-assessed and certified by the authorized signatory of the bidder, signing the bid.
- Where the total quoted value is INR 5 Crore or above:
 - i. The Proprietor and an independent Chartered Accountant, not being an employee of the firm, in case of a proprietorship firm.
 - ii. Any one of the partners and an independent Chartered Accountant, not being an employee of the firm, in case of a partnership firm.
 - iii. Statutory auditors in case of a company. However, where statutory auditors are not mandatory as per laws of the country where bidder is registered, an independent chartered accountant, not being an Employee of the bidder's organization.

26.0 CONDITIONS FOR START-UP COMPANIES

1. Subject to meeting of Quality and Technical specifications, MRPL may consider allowing the participation of all "Start-up" companies (and not limited to manufacturing sector), who are capable of executing the order as per technical specifications/ perform the job as per scope of work specified in the tender and subject to meeting extant & relevant guidelines of Government of India. This should be confirmed and substantiated in the technical bid. The startup bidder shall be required to submit an undertaking along with the bid stating that they will comply with all quality requirement and technical specifications of the tender during execution.
2. To establish the quality and technical specification of the tendered items Technical Capability, following criteria to be ensured as applicable;



**PROCUREMENT OF VALVES FOR CONFIDENTIAL DEMO PLANT AT
MRPL, MANGALURU, KARNATAKA**

- a) The bidder who intends to participate as “Start-up” company should enclose the `Certificate of Recognition issued by Department of Industrial Policy and Promotion(DIPP), Ministry of Commerce & Industry, Govt. of India during submission of Technical bid.
- b) Nature of Business mentioned in application made to get Start-up accreditation. Nature of Business should be related to tender item.
- c) A detailed Business Plan covering complete implementation of work with following points needs to be submitted as applicable;
 - Methodology to execute tendered work
 - Resource allocation & planning
 - CV/Qualification of Key executives
 - Working Capital & Finance Management
 - Safety, Security & statutory aspect
 - Any other important points which would be helpful to prove quality & technical capability.
- d) Certificate of Incorporation.
- e) Audited Balance sheet (P&L statement) of all the financial year since incorporation.
- f) The Start-up companies, recognized by DIPP are exempted from Bid Security Declaration in lieu of EMD.
- g) Prequalification Criteria with respect to Prior Turnover and Prior Experience may be relaxed for Start-ups as per the GOI guidelines.
- h) However, there may be circumstances like procurement of items/services related to public safety, health, critical security operations and equipment, etc wherein MRPL reserves the right to not consider relaxation of Prior Turnover and Prior Experience for Start-up Companies as per GOI guidelines.
- i) Start-up Companies who are also registered as MSEs and wish to avail the benefits as applicable to MSE, shall submit relevant documents covered under Conditions for Micro and Small Enterprises elsewhere in this tender.
- j) Based upon above documents / details, if MRPL is not convinced on meeting quality and technical capability of the bidder on the tendered items is able to execute the subject tender, the bid may be rejected without any further notice / communication to the bidder.

Bid Evaluation in case of tie:

- In case of tie at the lowest bid (L1) position between two or more startup/non-startup bidders, the order will be placed on the bidder who has higher/highest turnover in last audited financial year.
- In case there is tie at the lowest bid (L1) position between only startup bidders and none of them has past turnover, the order will be placed on the startup who is registered earlier with Department of Industrial Promotion and Policy.

27.0 PURCHASE PREFERENCE LINKED WITH LOCAL CONTENT (PP-LC 2017) –

MOP&NG has notified the purchase preference(linked with local content)-PP-LC for the Procurement of goods and services under Oil & Gas Projects in India. Under this Policy, the



**PROCUREMENT OF VALVES FOR CONFIDENTIAL DEMO PLANT AT
MRPL, MANGALURU, KARNATAKA**

bidders are allowed to avail the purchase preference linked with attaining the stipulated Local content.

MRPL reserves the right to allow Manufacturers or Suppliers or Service providers, purchase preference as admissible under the prevailing policy, subject to their complying with the requirements/conditions defined herewith and submitting documents required to support the same. In order to avail the Purchase preference under this policy, bidder shall achieve minimum Local Content (LC) for enquiries floated year-wise (Date of Notice inviting tender) as per table given below.

Table of Local Content-Enclosure-1

Items	Local Content (%)		
	2017-18	2018-20	2020-22
Service Contracts	20%	22%	25%
Supply Contracts	20%	22%	25%
EPC Contracts (others)	30%	35%	40%

Notes

1. Above policy is not applicable for Domestically Manufactured Electronic Products (DMEP) and MSME as there being specific policies for products/services
2. The prescribed local content in above table shall be applicable on the date of Notice Inviting Tender.

A) Margin of Purchase Preference

The manufacturers/service providers having the capability of meeting/ exceeding the local content targets given above shall be eligible for 10% purchase preference under the policy. i.e where the quoted price of eligible LC manufacturers/LC service providers is within 10% of the lowest price, purchase preference may be granted at the lowest valid price bid.

B) Procedure for availing benefits under Purchase Preference (Make in India Policy)

The option in case of MSE bidders qualifying under both Policies, namely, Purchase Preference under the Public Procurement Policy – 2012 (PPP-2012) for MSE bidders and Purchase Preference Linked with Local Content (PP-LC 2017) shall be exercised as under:

- i. The MSE bidder can avail only one out of the two applicable purchase preference policies, i.e., PP-LC 2017 for PPP-2012 and therefore, bidder will be required to furnish the option under which he desires to avail purchase preference. This option must be declared within the offer and in case bidder fails to do so although he is eligible for both the Policies, MRPL shall evaluate his offer considering PPP- 2012 as the default chosen option.



**PROCUREMENT OF VALVES FOR CONFIDENTIAL DEMO PLANT AT
MRPL, MANGALURU, KARNATAKA**

- ii. In case a MSE bidder opts for preference under PPP-2012, he shall not be eligible to claim benefit under PP-LC 2017 (irrespective of the fact whether he furnishes the details of LC in his offer and this LC meets the stipulated LC criteria).
- iii. In case a MSE bidder opts for purchase preference based on PP-LC 2017, he shall not be entitled to claim benefit of purchase preference benefit as applicable for MSE bidders under PPP-2012. However the exemptions from furnishing Bid Security Declaration in lieu of EMD shall continue to be available to such a bidder.
- iv. In view of the above
 - a) The bidder's quoted prices against various items of enquiry shall remain valid even in case of splitting of quantities of the items, except in case of items where the quantity cannot be split since these are to be awarded in a Lot or as a package or Group.
 - b) While evaluating the bids, for price matching opportunities and distribution of quantities among bidders, the order of precedence shall be as under:
 - MSE bidder (PPP-2012)
 - PP-LC complied bidder (PP-LC)

In case the bidder has not declared his status as to whether he is an MSE Bidder or PP-LC Bidder during bid submission, then he will be considered as non PP-LC compliant bidder and evaluated accordingly. No further correspondence will be made in this regard.

Examples of Purchase Preference:

Non divisible item

L1 bidder is non MSE, non PP-LC bidder

L2 bidder is PP-LC (**within 10%**)

L3 bidder is MSE bidder (**within 15%**)

MSE bidder shall be given preference to match the L1 price. If L3 bidder matches the L1 price, Order shall be placed on him, otherwise, option for matching the L1 price shall be given to L2 bidder (PP-LC).

Divisible item

L1 bidder is non MSE, non PL-LC bidder

L2 bidder is PP-LC (within 10%)

L3 bidder is MSE bidder (within 15%)

MSE bidder shall be given preference to match the L1 price. If bidder matches the L1 price, order shall be placed on him for the quantity specified in the bidding document. For the balance quantity (i.e. 50% of tendered quantity/value) option for matching the L1 price shall be given to L2 bidder (PP-LC). Balance quantity shall be awarded to natural lowest bidder.



**PROCUREMENT OF VALVES FOR CONFIDENTIAL DEMO PLANT AT
MRPL, MANGALURU, KARNATAKA**

For further clarification, in case an item has quantity 4 nos. then 1 no. can be given to MSE bidder, 2 to PP-LC bidder and left out 01 no. to natural L1 bidder.

Note:

The above two examples are not applicable to the Works Contracts since the Purchase Preference under PPP-2012 is not applicable to works contracts.

- In case lowest bidder is a MSE bidder, the entire work shall be awarded to him without resorting to purchase preference to bidders complying with Local Content.
- In case lowest bidder is a PP-LC bidder, purchase preference shall be resorted to MSE bidder as per provisions specified in the enquiry document w.r.t. PPP-2012 only.

The PP-LC Policy shall be implemented in the following manner

Quantum of purchase preference for bidders qualifying under local content (for LC Bidder) meeting minimum local content, subject to accepting L1 Price and tender applicability criteria, referred to as eligible LC bidder as explained under previous sections are stated below.

A. For goods

- 1) If L-1 is LC bidder, entire quantity will be awarded to such LC bidder
- 2) If L-1 is non-LC bidder,
 - a) 50% of the quantity will be awarded to LC bidder and rest to non-LC bidder
 - b) If quantity cannot be split in the ratio of 50:50, the next higher quantity greater than 50% that is practically splittable shall be awarded to LC bidder and rest to non-LC bidder
 - c) If quantity is indivisible, 100% shall be awarded to LC bidder
 - d) If there are more than one LC bidders, 50% quantity shall be awarded to lowest LC bidder and rest to non LC bidder

B. For Services/ EPC contracts.

Normally the service / EPC contract are not splittable and therefore the eligible LC bidder shall be awarded 100% of the contract. However, in cases where the contract are splittable the LC bidder shall be awarded contract as explained under section A.2) above as in procurement of goods.

C) CERTIFICATION OF LOCAL CONTENT

Manufacturers of goods and/or providers of service, seeking Purchase preference under the policy, shall be obliged to certify the LC of goods, service or EPC contracts as under:

At bidding stage:

The bidder shall provide the percentage local content in the bid (Unpriced Bid)

The bidder must have LC in excess of the requirement specified in table given in Enclosure-1



**PROCUREMENT OF VALVES FOR CONFIDENTIAL DEMO PLANT AT
MRPL, MANGALURU, KARNATAKA**

- The bidder shall submit an undertaking from the authorized signatory of the bidder having **the power of attorney** along with the bid stating the bidder meets the mandatory minimum local content requirement, which shall become part of the contract.
- In cases of procurement for an estimated value in excess of Rs 10 Crores, the undertaking submitted by the bidder shall be supported by a certificate from the **statutory auditor or cost auditor** of the company (in case of companies) or from a **practicing cost accountant or practicing chartered accountant** (in respect of other than companies) **giving the percentage of local content**.
- However, in case of foreign bidder, certificate from the statutory auditor or cost auditor of their own office or subsidiary in India giving the percentage of LC is also acceptable. In case office or subsidiary in India does not exist or Indian office/subsidiary is no required to appoint statutory auditor or cost auditor, certificate from practicing cost accountant or practicing chartered accountant giving the percentage of LC is also acceptable.

After awarding of Contract/Purchase Order

The LC Certificate as per Table attached as per relevant Enclosures (II,III& IV) shall be submitted along with each Invoice as per following criteria

a) Where the total quoted value is less than INR 5 Crore:

In the case of procurement of goods and or services with the value less than Rs Five Crores, the local content shall be calculated (self-assessment) by the supplier of goods and/or the provider of services and certified by the Director/ Authorised representative of the company

b) Where the total quoted value is INR 5 Crore or above -The verification of the procurement of goods, services or EPC contracts with the value Rupees Five Crore and above shall be carried out as follows

- i. The Proprietor and an independent Chartered Accountant, not being an employee of the firm, in case of a proprietorship firm.
- ii. Any one of the partners and an independent Chartered Accountant, not being an employee of the firm, in case of a partnership firm.
- iii. Statutory auditors in case of a company. However, where statutory auditors are not mandatory as per laws of the country where bidder is registered, an independent chartered accountant, not being an Employee of the bidder's organization.

However, procuring company shall also have the authority to audit as well as witness production processes to certify the achievement of the requisite local content and/or to obtain the complete back up calculation before award of work failing which the bid shall be rejected and appropriate action may be initiated against the bidder.

D) CALCULATION AND DETERMINATION OF LOCAL CONTENT

Bidder claiming Local Content have to calculate the LC and indicate the same in the Unpriced Bid and substantiate the calculation while submitting each invoice



**PROCUREMENT OF VALVES FOR CONFIDENTIAL DEMO PLANT AT
MRPL, MANGALURU, KARNATAKA**

1. LC shall be calculated on the basis of verifiable data. In the case of data used in the calculation of LC being non verifiable, the value of LC of the said component shall be treated as nil.
2. Format for calculation of LC is enclosed as
 - a) Enclosures II, for procurements of
 - a) Supply of goods
 - i) Supply of goods along with installation and commissioning
 - ii) Supply of goods along with installation , commissioning & AMC
 - b) Enclosure III for calculation of LC for Services
 - c) Enclosure IV for calculation of LC for EPC
3. Determination of Local Content
 - a) For Goods/installation & commissioning/AMC as evaluated under Enclosure II
 - i. LC of goods shall be computed on the basis of the cost of domestic components in goods, compared to the whole cost of product. The whole cost of product shall be constituted of the cost spent for the production of goods, covering: direct component (material) cost; direct manpower cost, factory overhead cost and shall exclude profit, company overhead cost and taxes for the delivery of goods.
 - ii. The criteria for determination of local content cost shall be as following
 - In the case of direct component (material) based on country of Origin
 - In the case of manpower, based on INR component
 - In the case of working equipment/facility, based on the country of Origin
 - iii. The calculation of LC of the combination of several kinds of goods shall be based on the ratio of the sum of the multiplication of LC of each goods with the acquisition price of each goods to the acquisition price of the combination of goods
 - b) For services as evaluated under Enclosure III
 - I) LC of service shall be calculated on the basis of the ratio of service cost of domestic component in service to the total cost of service
 - II) The total cost of service shall be constituted of the cost spent for rendering of service covering
 - Cost of component (material) which is used
 - Manpower and consultant cost, cost of working equipment/facility and
 - General service cost excluding profit, company overhead cost , taxes and duties
 - III) The criteria for determination of cost of local content in the service shall be as follows
 - In the case of material being used to help the provision of service, based on country of origin
 - In the case of manpower and consultant based on INR component of the services contract
 - In the case of working equipment/facility, based on the country of Origin and



**PROCUREMENT OF VALVES FOR CONFIDENTIAL DEMO PLANT AT
MRPL, MANGALURU, KARNATAKA**

- In the case of general service cost, based on the criteria mentioned under 3.b)III above
 - Indian flag vessels in operation as on date
- c) LC of EPC contracts given under Enclosure IV
- I) LC of EPC contracts shall be ratio of the whole cost of domestic components in the combination of goods and services to the whole combined cost of goods and services
 - II) The whole combined cost of goods and services shall be the cost spent to produce the combination of goods and services, which is incurred on work site. LC of the combination of goods and services shall be counted in every activity of the combination work of goods and services
 - III) The spent cost as mentioned above(3.c.II) shall include production cost in the calculation of LC of goods as mentioned in 3.a.I and service cost in the calculation of LC of services as mentioned in clause 3.b.II
- d) Determination of LC of the working equipment/facility shall be based on the following provision. Working equipment produced in the country is valued as 100% local content and working equipment produced abroad is valued as Nil Local Content (0%)
- e) As regards cases where currency quoted by the bidder is other than INR, exchange rate prevailing on the date of Tender (NIT) shall be considered for the calculation of LC

The onus of submission of appropriately certified documents lies with the bidder and purchaser shall not have any liability to verify the contents & will not be responsible for same.

However, in case the procuring company has any reason to doubt the authenticity of the Local Content, it reserves the right to obtain the complete back up calculations before award of work failing which the bid shall be rejected.

E) Failure of bidder in complying with the local content post award:

In case a bidder, who has specified in his bid that the bid meets the minimum Local Content specified in the enquiry document fails to achieve the same the following actions shall be taken by the procuring company:

- a. Pre-determined penalty @ 10% of total contract value.
- b. Banning business with the supplier/contractor for a period of one year

To ensure the recovery of above pre-determined penalty, payment against dispatch/shipping document shall be modified to the extent that the 10% payment out of this milestone payment shall be released after completion of this milestone as well as submission of certification towards achievement of Local Content, as per provision of enquiry document. Alternatively, this payment can be released against submission of additional bank guarantee valid till completion Schedule Plus 3 months or as required by purchasing company.



**PROCUREMENT OF VALVES FOR CONFIDENTIAL DEMO PLANT AT
MRPL, MANGALURU, KARNATAKA**

Enclosure-II

CALCULATION OF LOCAL CONTENT – GOODS

Name of Manufacturer	Calculation by manufacturer			
	Cost per one unit of product			
Cost component	Cost (Domestic component) a	Cost (Imported component) b	Cost Total Rs/US\$ C=a+b	% Domestic component d=a/c
I. Direct material cost				
II. Direct labour Cost				
III. Factory overhead				
IV. Total production cost				

Note:

% LC Goods = $\frac{\text{Total cost (IV.c)} - \text{Total imported component cost (IV.b)}}{\text{Total Cost (IV.c)}} \times 100$

Total Cost (IV.c)

% LC Goods = $\frac{\text{Total domestic component cost (IV.a)}}{\text{Total Cost (IV.c)}} \times 100$

Total Cost (IV.c)



**PROCUREMENT OF VALVES FOR CONFIDENTIAL DEMO PLANT AT
MRPL, MANGALURU, KARNATAKA**

Enclosure-III

CALCULATION OF LOCAL CONTENT – SERVICE

NAME OF SUPPLIER OF GOODS/PROVIDER OF SERVICE							
			Cost Summary				
			Domestic	Imported Rs/US\$	Total	LC	
						%	Rs/US\$
b	c	d	e=b/d	f=d x e			
A	Cost component						
	I. Material used cost	Rs US\$					
	II. Personnel & Consultant cost	Rs US\$					
	III. Other services cost	Rs US\$					
	IV. Total cost (I to IV)	Rs US\$					
B	Taxes and Duties	Rs US\$					
C	Total quoted price	Rs US\$					

Note:

% LC Service = $\frac{\text{Total cost (A. IV. d)} - \text{Total imported component cost (A. IV. c)}}{\text{Total Cost (A. IV. d)}} \times 100$

Total Cost (A. IV. d)

% LC Service = $\frac{\text{Total domestic component cost (A. IV. b)}}{\text{Total Cost (A. IV. d)}} \times 100$

Total Cost (A. IV. d)



**PROCUREMENT OF VALVES FOR CONFIDENTIAL DEMO PLANT AT
MRPL, MANGALURU, KARNATAKA**

Enclosure-IV

CALCULATION OF LOCAL CONTENT –EPC (GOODS AND SERVICE)

A.	COST COMPONENT (Rs/US\$)	Cost Summary				
		Domestic	Imported Rs/US\$	Total	LC	
					%	Rs/US\$
		b	c	d	e=b/d	f=d x e
I	GOODS					
1.	Material used cost					
2.	Equipment cost					
3.	Sub Total I					
II	SERVICES					
1.	Personnel & Consultant cost					
2.	Equipment & WorkFacility Cost					
3.	Construction/Fabrication Cost					
4.	Other Services Cost etc					
5.	Sub Total II					
III.	TOTAL COST GOODS + SERVICES					
B.	Non Cost Component					
C.	TOTAL QUOTED PRICE					

Note:

% LC Combination =

$$\frac{\{\text{Total domestic component cost of goods (AI3b)} + \text{Total domestic component cost of service (AI5b)}\}}{\text{Total Cost (AIId)}} \times 100$$



**PROCUREMENT OF VALVES FOR CONFIDENTIAL DEMO PLANT AT
MRPL, MANGALURU, KARNATAKA**

1. Total Bill of Materials

- a) Sum of the costs of all the inputs which go into the product (including duties and taxes levied on procurement of inputs except those for which credit/setoff can be taken)
- b) Ex-factory price of product minus profit after tax, minus warranty costs
- c) Market price minus post production freight, insurance and other handling cost minus profit after tax minus warranty cost minus sales and marketing expenses.

The percentage domestic value addition shall be calculated as per the following formula,

$$\% \text{ Domestic Value addition} = \text{Domestic Bill of Material} / \text{Total Bill of Material}$$

Under “notification for electronics products under public procurement order 2017” **Public procurement (Preference to Make in India)-order 2017-Notification on Cellular Mobile Phones.**

In furtherance of above order, MeITy has added cellular Mobile Phones vide notification no 33(5)/2017-IPHW dated 1/08/2018 and can be downloaded from http://dipp.nic.in/sites/default/files/Meity_dated_01082018.pdf

Public Procurement (Preference to Make in India) Order 2018 for Cyber Security Products

MeITy has issued notification viz File No 1 (10)/2017-CLSES dated 2/7/2018 to give purchase preference to domestically manufactured /produced Cyber Security Products as per the above Order.

The definition of cyber security product, local supplier of domestically manufactured Cyber Security Products, exclusions, Verifications etc are available under <http://meity.gov.in/cyber-security>

The local supplier at the time of bidding shall provide self-certification that the item offered meets the definition of local supplier of domestically manufactured/ produced Cyber Security Products.

Certification authority for estimated values beyond Rs 10 Crores shall be statutory auditor or cost auditor of the company (in case of companies).

In case of false declarations, provisions under clause-24-Instructions to Bidders of Section-1 of Tender Document will apply. Complaints received against claims of a bidder regarding supply of domestically manufactured Cyber Security Product shall be referred to STQC under MeITy.

For certification of local content in electronic goods shall be as per the circular F.No.33(1)/2017-IPHW issued by Government of India Ministry of Electronics and Information Technology dated 14th September 2017, which may be downloaded from <http://meity.gov.in/esdm/ppo>

Purchase Preference in case where Negotiation is also required:

In case purchase preference is applicable, but negotiation is to be conducted with L1 bidder, negotiation shall be carried out MSE and/or LC-complied bidder shall be offered to match the negotiated prices (even if, post negotiation, they are higher by more than 10% as compared to L1



**PROCUREMENT OF VALVES FOR CONFIDENTIAL DEMO PLANT AT
MRPL, MANGALURU, KARNATAKA**

bidder provided they were within 10% of L1 bidder as per original quoted prices) and left out quantity, if any, as per provisions of enquiry document shall be awarded to that bidder.

Note:

Relevant policy guidelines issued including modifications made from time by the concerned Ministry in respect to Purchase Preference to Make in India, shall be applicable.

UNDERTAKING (To be submitted on Company's Letterhead)

(Where the total quoted value is less than INR 5 Crore)

I _____, Son/ Daughter of _____, do solemnly affirm and state as under:

1. That I am the _____ <<Designation of the authorized signatory>> of _____ and I am duly authorized to furnish this undertaking declaration on behalf of _____.
2. That _____ has submitted its bid no _____ dated _____ against bidding document no _____ dated _____ for _____ item / works for _____.
3. That the Company is fully aware of the provisions of Purchase Preference (Linked with Local Content) 2017 (PP-LC) Policy, enclosed in the above bidding document.
4. We hereby confirm that our offer is achieving the minimum local content target as per of PP-LC Policy.
5. I confirm that I am aware of the implication of the above undertaking and our liability on account of wrong declaration.

(Authorized signatory of Supplier)

Note : This undertaking shall be certified by the authorized signatory of the bidder, signing the bid.



**PROCUREMENT OF VALVES FOR CONFIDENTIAL DEMO PLANT AT
MRPL, MANGALURU, KARNATAKA**

UNDERTAKING (To be submitted on Company's Letterhead)

(Where the total quoted value is INR 5 Crore or above)

Certification by the bidder

I _____, Son/ Daughter of _____, do solemnly affirm and state as under:

1. I am the _____ <<Designation of the authorized signatory>>of _____ and I am duly authorized to furnish this undertaking declaration on behalf of _____.

2. That _____ has submitted its bid no _____ dated _____ against bidding document no _____ dated _____ for _____ item / works for _____.

3. That the Company is fully aware of the provisions of Purchase Preference (Linked with Local Content) 2017 (PP-LC) Policy, enclosed in the above bidding document.

4. We hereby confirm that our offer is achieving the minimum local content target as per of PP-LC Policy and the break-up of the same is provided in the Priced bid.

5. I confirm that I am aware of the implication of the above undertaking and our liability on account of wrong declaration.

(Authorized signatory of Supplier)

Certification by the statutory auditor / Chartered Accountant of the bidder

We, _____, a CA firm having our registered office address _____ and certificate number _____ certify that we are statutory auditor of the Company M/s _____, having its registered office at _____.

OR

We, _____, a CA firm having our registered office address _____ and certificate number _____ certify that statutory auditor is not mandatory for the company M/s _____, having its registered office at _____ as per prevailing law and we are practicing Chartered Accountant, not being an employee / Director and not having any interest in the company.

We have understood the provisions of Purchase Preference (Linked With Local Content) 2017 (PP-LC) Policy, enclosed in the above bidding document.

We hereby certify that offer is achieving the minimum local content target as per of PP-LC Policy.

(Statutory auditor / Chartered Accountant of the bidder)

Note : This undertaking shall be certified by:



**PROCUREMENT OF VALVES FOR CONFIDENTIAL DEMO PLANT AT
MRPL, MANGALURU, KARNATAKA**

The Proprietor and an independent Chartered Accountant, not being an employee of the firm, in case of a proprietorship firm.

ii. Any one of the partners and an independent Chartered Accountant, not being an employee of the firm, in case of a partnership firm.

iii. Statutory auditors in case of a company. However, where statutory auditors are not mandatory as per laws of the country where bidder is registered, an independent chartered accountant, not being an Employee of the bidder's organization.

LIST OF ITEMS / SERVICES TO BE PROCURED FROM INDIAN MANUFACTURERS/SERVICE

The list of items to be procured from Indian manufacturer /services are as follows:

- 1
- 2
- 3
- 4



**PROCUREMENT OF VALVES FOR CONFIDENTIAL DEMO PLANT AT
MRPL, MANGALURU, KARNATAKA**

Subject: Policy to provide Purchase preference (linked with local content) (PP – LC) in all Public Sector Undertakings under Ministry of Petroleum and Natural Gas- Amended

1 Preamble

- 1.1 In tune with Make in India (MII) campaign in oil and gas sector, the Government has decided to incentivise the growth in local content in goods and services while implementing oil and gas projects in India, and
- 1.2 Whereas the Public procurement policy rests upon the core principles of competitiveness, adhering to sound procurement practices and execution of orders for supply of goods or services in accordance with a system which is fair, equitable, transparent, competitive and cost effective, and
- 1.3 Whereas, the local content can be increased through partnerships, cooperation with local companies, establishing production units in India or Joint Ventures (JV) with Indian suppliers, increasing the participation of local employees in services and training them etc.
- 1.4 Whereas incentivising enhanced local content in the procurement of goods and/or services in oil and gas business activities would lead to increased local industry content;
- 1.5 Therefore, the Ministry of Petroleum and Natural Gas (MoPNG) has decided to stipulate the following policy for providing Purchase Preference to the manufacturers/ service providers having the capability of meeting/ exceeding the local content targets in oil and gas business activities;
- 1.6 This policy considers the Local Content (LC) as the added value brought to India through the activities of the oil and gas industry. This may be measured (by project, affiliate, and/or country aggregate) and undertaken through Workforce development and investments in supplier development through developing and procuring supplies and services locally.

2 Definitions

- 2.1 **Oil and Gas Business Activity** shall comprise of Upstream, Midstream and Downstream business activities.

Page 1 of 12



**PROCUREMENT OF VALVES FOR CONFIDENTIAL DEMO PLANT AT
MRPL, MANGALURU, KARNATAKA**

- 2.2 **Domestic products** shall be goods and/or service (including design and engineering), produced by companies, investing and producing in India.
- 2.3 **Local Content** hereinafter abbreviated to LC means the amount of value added in India which shall, unless otherwise prescribed by the Nodal Ministry, be the total value of the item procured (excluding net domestic indirect taxes) minus the value of imported content in the item (including all customs duties) as a proportion of the total value, in percent.
- 2.4 **Domestic Manufacturer** shall be business entity or individual having business activity established under Indian law and producing products domestically.
- 2.5 **Supplier** of goods and/or provider of service shall be a business entity having capability of providing goods and/or service in accordance with the business line and qualification thereof and classified as under:
- 'Class-I local supplier' means a supplier or service provider, whose goods, services or works offered for procurement, has local content equal to or more than 50% as defined under this Policy.
- 'Class-II local supplier' means a supplier or service provider, whose goods, services or works offered for procurement, has local content more than or equal to 20% but less than 50%, as defined under this Policy.
- 'Non-local supplier' means a supplier or service provider, whose goods, services or works offered for procurement, has local content less than 20%, as defined under this Policy.
- 2.6 **Steering Committee** means the committee to be constituted by MoPNG to provide effective guidance and to oversee the implementation of the Policy on a regular and continuing basis.
- 2.7 **Verification** shall be an activity to verify the accomplishment of LC by domestic manufacturers and/or suppliers of goods and/or providers of service with the data obtained or collected from respective business activities.
- 2.8 **Purchase preference:** Where the quoted price is within the margin of purchase preference of the lowest price, other things being equal, purchase preference may be granted to the bidder concerned, at the lowest valid price bid.



**PROCUREMENT OF VALVES FOR CONFIDENTIAL DEMO PLANT AT
MRPL, MANGALURU, KARNATAKA**

- 2.9 **Local Content (LC)** in Goods shall be the use of raw materials, design and engineering towards manufacturing, fabrication and finishing of work carried out within the country.
- 2.10 **Local Content (LC)** in Services shall be the use of services up to the final delivery by utilizing manpower (including specialist), working appliance (including software) and supporting facilities carried out within in the country.
- 2.11 **Local Content (LC)** in EPC contracts shall be the use of materials, design and engineering comprising of manufacturing, fabrication, assembly and finishing as well as the use of services by utilizing manpower (including specialist), working appliance (including software) and supporting facility up to the final delivery, carried out within the country.
- 2.12 **Factory overhead cost** shall be indirect costs of manpower, machine/working appliance/facility and the whole other fabrication costs needed to produce a unit of product with the cost not chargeable directly to specified product.
- 2.13 **Company overhead cost** shall be costs related to the marketing, administration and general affairs cost of the company.
- 2.14 **Indian Company** means a company formed and registered under the Companies Act, 2013.
- 2.15 **Foreign company** means any company or body corporate incorporated outside India which— (a) has a place of business in India whether by itself or through an agent, physically or through electronic mode; and (b) conducts any business activity in India in any other manner.
- 3. Scope**
- 3.1 The regulation shall be intended to:
- 3.1.1 Support and boost the growth of domestic manufacturing sector so as to be able to support oil and natural gas business activities and contribute added value to economy, absorb manpower as well as have national, regional and international competitiveness;



**PROCUREMENT OF VALVES FOR CONFIDENTIAL DEMO PLANT AT
MRPL, MANGALURU, KARNATAKA**

- 3.1.2 Support and boost the growth of innovation/technology of domestic manufacturing sector.
- 3.2 This policy shall apply to all the Public Sector Undertakings and their wholly owned subsidiaries under the Ministry of Petroleum and Natural Gas; Joint Ventures that have 51% or more equity by one or more Public Sector Undertakings under the Ministry of Petroleum and Natural Gas; attached and subordinate offices of MoPNG.
- 3.3 This policy shall not include goods/ services falling under Micro Small and Medium Enterprises (MSME) or Domestically Manufactured Electronic Products (DMEP), as those products/ services are already covered under specific policy. However, an option would be given in the tender for the bidder to declare preference for seeking benefit under PP-LC/MSME or DMEP.
- 3.4 The policy is not applicable for HP-HT operations for the time being. The Charter Hiring of offshore vessels shall continue to be governed by DG, Shipping Guidelines. Indian Flag Vessels shall be considered as having 100% LC.
- 3.5 The prescribed local content in the Policy shall be applicable on the date of Notice inviting Tender.
- 4. Procurement**
- 4.1 The procuring companies shall follow their own procurement procedures. Aggregation of annual requirements and such other procurement practices, which facilitate the implementation of this policy, may be adopted by procuring companies.
- 4.2 In respect of Global Tender Enquiry (GTE) the guidelines as issued by Government of India from time to time shall be applicable on the procuring entities.
- 4.3 **Margin of Purchase preference:** The margin of purchase preference shall be 20%.
- 4.4 (a) In respect of all goods, services or works in respect of which the Nodal Ministry/ Department under DPIIT's Public Procurement (Preference to Make in India) Order, 2017 has communicated that there is sufficient local capacity and local competition, only Class-I local supplier shall be eligible to bid irrespective of purchase value.
-



**PROCUREMENT OF VALVES FOR CONFIDENTIAL DEMO PLANT AT
MRPL, MANGALURU, KARNATAKA**

- 4.4 (b) For all other local tenders, Class-I local supplier and Class-II local supplier shall be eligible to bid irrespective of purchase value, but preference to be given as per PP-LC to the Class-I local supplier.
- 4.4 (c) Only Class-I local supplier and Class-II local supplier, as defined under the Order, shall be eligible to bid in procurements undertaken by procuring entities, except when Global tender enquiry has been issued. In global tender enquiries, Non-local suppliers shall also be eligible to bid along with Class-I local suppliers and Class-II local suppliers.
- 4.4 (d) Class-II local supplier will not get purchase preference in any procurement, undertaken by procuring entities.
- 4.5 In National Competitive Bid procurements of all items not covered by para 4.4 (a) and where the estimated value to be procured i.e. total value of enquiry/ tender, is less than Rs. 1 Crore shall be exempt from this Policy. In case of International Competitive Bids, the policy shall be applicable irrespective of the tender estimate. However, it shall be ensured by procuring entities that procurement is not split for the purpose of avoiding the provisions of this Policy.
- 4.6 The producers of goods and/or providers of services shall be obliged to fulfil the requirements of quality and delivery time in accordance with the provisions of the respective contracts of goods and services.
- 4.7 If the Ministry is satisfied that Indian suppliers of an item are not allowed to participate and/or compete in procurement by any foreign government, it may, if it deems appropriate, restrict or exclude bidders from that country from eligibility for procurement of that item and/or other items relating to the Ministry.
- 4.8 For the purpose of para 4.7 above, a supplier or bidder shall be considered to be from a country if (i) the entity is incorporated in that country, or (ii) a majority of its shareholding or effective control of the entity is exercised from that country, or (iii) more than 50% of the value of the item being supplied has been added in that country. Indian suppliers shall mean those entities which meets any of these tests with respect to India.
- 5. Purchase Preference- Linked with Local Content (LC)**
- 5.1 In procurement of all items not covered by para 4.4 (a), the following provisions may be considered for LC linked Purchase Preference:



**PROCUREMENT OF VALVES FOR CONFIDENTIAL DEMO PLANT AT
MRPL, MANGALURU, KARNATAKA**

- 5.1.1 The manufacturers/ service providers having the capability of meeting/ exceeding the local content targets shall be eligible for purchase preference under the policy, i.e. LC manufacturers/ LC service providers respectively as described below.
- 5.1.2 Wherever the goods/ services are procured under this policy, eligible (techno-commercially qualified) Class I Local supplier may be granted a purchase preference where the quoted price is within the margin of purchase preference of the lowest price, other things being equal, purchase preference may be granted to the eligible (techno-commercially qualified) Class I Local supplier concerned, at the lowest valid price bid.
- 5.1.3 **Goods:** The tender for procuring goods would specify that the contract for 50% of the procured quantity would be awarded to the lowest techno-commercially qualified Class I Local supplier, subject to matching with L1, if such bidders are available. The remaining will be awarded to L1.
- 5.1.3.1 However, if L1 bidder happens to be a Class I Local supplier, the entire procurement value shall be awarded to such bidder;
- 5.1.3.2 If in the opinion of the procuring company, the tenders (procured quantity) cannot be divided in the prescribed ratio of 50:50, then they shall have the right to award contract to the eligible Class I Local supplier for quantity not less than 50%, as may be divisible.
- 5.1.3.3 In continuation to 5.1.3.2 above, if the tendered item is non divisible, (to be included in the tender document by procuring company) the contract can be awarded to the eligible Class I Local supplier for the entire quantity.
- 5.1.4 **Services/ EPC Contracts:** The tender for oil and gas services/ EPC contracts shall not normally be split. For such procurement the tender would specify that the entire contract would be awarded to the lowest techno-commercially qualified Class I Local supplier, subject to matching with L1, if such bidders are available. However, tender for certain oil & gas services can normally be split, in such cases, splitting shall be allowed and specified in tender document. Such services shall follow the procedure outlined for goods as described in para 5.1.3. The procuring company should clearly specify in the tender document whether the tender shall be split or not.



**PROCUREMENT OF VALVES FOR CONFIDENTIAL DEMO PLANT AT
MRPL, MANGALURU, KARNATAKA**

- 5.1.5 For para 5.1.3 and 5.1.4 above, only those LC manufacturers/ service providers whose bids are within the margin of purchase preference would be allowed an opportunity to match L1 bid.
- 5.1.6 The tender conditions would ensure that local content in oil & gas products is encouraged. However, the procuring company may incorporate such stipulations as may be considered necessary to satisfy themselves of the production capability and product quality of the manufacturer.
- 5.1.7 The procedure for award under the policy is at **Enclosure-I**.

6. Determination of LC

6.1 LC of goods

- 6.1.1 LC of goods shall be computed on the basis of the cost of domestic components in goods, compared to the whole cost of product.
- 6.1.2 The criteria for determination of the local content cost in the goods shall be as follows:
- a) in the case of direct component (material), based on country of origin;
 - b) in the case of manpower, based on INR component.
- 6.1.3 The calculation of LC of the combination of several kinds of goods shall be based on the ratio of the sum of the multiplication of LC of each of the goods with the acquisition price of each goods to the acquisition price of the combination of goods.

6.2 LC of service

- 6.2.1 LC of Service shall be calculated on the basis of the ratio of service cost of domestic component in service to the total cost of service.
- 6.2.2 The total cost of service shall be constituted of the cost spent for rendering of service, covering:
- a) cost of component (material) which is used;
 - b) manpower and consultant cost; cost of working equipment/ facility; and
 - c) general service cost.



**PROCUREMENT OF VALVES FOR CONFIDENTIAL DEMO PLANT AT
MRPL, MANGALURU, KARNATAKA**

6.2.3 The criteria for determination of cost of local content in the service shall be as follows:

- a) in the case of material being used to help the provision of service, based on country of origin;
- b) in the case of manpower and consultant based on INR component of the services contract;
- c) in the case of working equipment/facility, based on country of origin; and
- d) in the case of general service cost, based on the criteria as mentioned in clauses a, b, and c above.
- e) Indian flag vessels in operation as on date.

6.3 LC of the EPC Contracts:

6.3.1 LC of EPC contracts shall be the ratio of the whole cost of domestic components in the combination of goods and services to the whole combined cost of goods and services.

6.3.2 The whole combined cost of goods and services shall be the cost spent to produce the combination of goods and services, which is incurred on work site. LC of the combination of goods and services shall be counted in every activity of the combination work of goods and services.

6.3.3 The spent cost as mentioned in paragraph 6.3.2 shall include production cost in the calculation of LC of goods as mentioned in clause 6.1.1 and service cost in the calculation of LC of services as mentioned in clause 6.2.2.

6.4 Calculation of LC and Reporting

LC shall be calculated on the basis of verifiable data. In the case of data used in the calculation of LC being not verifiable, the value of LC of the said component shall be treated as nil.

7 Certification and Verification

7.1 Class I/Class II Local suppliers are eligible to bid only if they meet the local content norms, therefore whether or not they want to avail PP-LC benefit, it will still be mandatory for them to give adequate documentation as follows to establish their status as class-I or class-II local supplier:

7.1.2 At bidding stage:

- a) Price Break-up:
 - The bidder shall provide the percentage of local content in the bid.



**PROCUREMENT OF VALVES FOR CONFIDENTIAL DEMO PLANT AT
MRPL, MANGALURU, KARNATAKA**

b)

- The bidder shall submit an undertaking from the authorised signatory of bidder having the power of Attorney alongwith the bid stating the bidder meets the mandatory minimum LC requirement and such undertaking shall become a part of the contract.
- In cases of procurement for a value in excess of Rs 10 crores, the undertaking submitted by the bidder shall be supported by a certificate from the statutory auditor or cost auditor of the company (in case of companies) or from a practicing cost accountant or practising chartered accountant (in respect of other than companies) giving the percentage of local content.
- However, in case of foreign bidder, certificate from the statutory auditor or cost auditor of their own office or subsidiary in India giving the percentage of local content is also acceptable. In case office or subsidiary in India does not exist or Indian office/ subsidiary is not required to appoint statutory auditor or cost auditor, certificate from practising cost accountant or practising chartered accountant giving the percentage of local content is also acceptable.

7.1.3 After Contract Award:

- The bidder shall submit an undertaking from the authorised signatory of bidder having the power of Attorney alongwith the bid stating the bidder meets the mandatory minimum LC requirement and such undertaking shall become a part of the contract.
 - In cases of procurement for a value in excess of Rs 10 crores, the undertaking submitted by the bidder shall be supported by a certificate from the statutory auditor or cost auditor of the company (in case of companies) or from a practicing cost accountant or practising chartered accountant (in respect of other than companies) giving the percentage of local content.
 - However, in case of foreign bidder, certificate from the statutory auditor or cost auditor of their own office or subsidiary in India giving the percentage of local content is also acceptable. In case office or subsidiary in India does not exist or Indian office/ subsidiary is not required to appoint statutory auditor or cost auditor, certificate from practising cost accountant or practising chartered accountant giving the percentage of local content is also acceptable.
-



**PROCUREMENT OF VALVES FOR CONFIDENTIAL DEMO PLANT AT
MRPL, MANGALURU, KARNATAKA**

- 7.2 Each supplier shall provide the necessary local-content documentation to the statutory auditor, which shall review and determine that local content requirements have been met, and issue a local content certificate to that effect on behalf of the bidder, stating the percentage of local content in the good or service measured. The Auditor shall keep all necessary information obtained from suppliers for measurement of Local Content confidential.
- 7.3 The Local Content certificate shall be submitted along with each invoice raised. However, the % of local content may vary with each invoice while maintaining the overall % of local content for the total work/purchase of the pro-rata local content requirement. In case, it is not satisfied cumulatively in the invoices raised up to that stage, the supplier shall indicate how the local content requirement would be met in the subsequent stages.
- 7.4 As regards cases where currency quoted by the bidder is other than Indian Rupee, exchange rate prevailing on the date of notice inviting tender (NIT) shall be considered for the calculation of Local Content.
- 7.5 The Procuring Company shall also have the authority to audit as well as witness production processes to certify the achievement of the requisite local content.
- 8 Governance and Supervision**
- 8.1 A Steering Committee will be constituted by MoPNG to provide effective guidance and to oversee the effective implementation of the Policy including review and amendments required therein. The Steering Committee may consider representations on target Local Content in goods, services and EPC and modify the policy accordingly.
- 8.2 The Steering Committee shall annually conduct a review of the policy implementation which shall specifically cover the issue of whether there has been adequate competition, and whether the policy has resulted in any reduction in competition/ exclusion of non-local bidders or any cost increase to the purchasing PSU, particularly in respect of services & works contracts.
- 9 Sanctions**
- 9.1 The Procuring companies shall impose sanction on manufacturers/ service providers not fulfilling LC of goods/ services in accordance with the value mentioned in certificate of LC.
-



**PROCUREMENT OF VALVES FOR CONFIDENTIAL DEMO PLANT AT
MRPL, MANGALURU, KARNATAKA**

- 9.2 The sanctions may be in the form of written warning, financial penalty and blacklisting.
- 9.3 In the event that a manufacturer or supplier of goods and/or provider of services does not fulfil his obligation after the expiration of the period specified in such warning, the procuring company can initiate action for blacklisting such manufacturer/supplier/service provider.
- 9.4 A manufacturer and/or supplier of goods and/or provider of services who has been awarded the contract after availing Purchase Preference is found to have violated the LC provision, in the execution of the procurement contract of goods and/or services shall be subject to financial penalty specified in clause 9.4.1.
- 9.4.1 The financial penalty shall be over and above the PBG value prescribed in the contract and shall not be more than an amount equal to 10% of the Contract Price.
10. **Clarification on Goods/ Services:** Any issue regarding the coverage of a particular good/ service under the proposed policy would be referred to the Steering Committee for clarification.
11. **Powers to grant exemption and to reduce minimum local content:** Wherever proper justification exists, Ministry of Petroleum and Natural Gas may by written order, for reasons to be recorded in writing,
a) Reduce the minimum local content below the prescribed level; or
b) Reduce the margin of purchase preference below 20%; or
c) Exempt any particular item or supplying entities from the operation of this Order or any part of the Order.
12. **Time Period:** The Policy shall be applicable for 5 years. Except for 2017-18, the Policy shall not be continued unless, the Steering Committee by September 30th of each year, concludes a review as per para 8.2 of the Policy and recommends continuation of the Purchase Preference.
-



**PROCUREMENT OF VALVES FOR CONFIDENTIAL DEMO PLANT AT
MRPL, MANGALURU, KARNATAKA**

Enclosure-I

PROCEDURE FOR AWARD OF CONTRACTS

Procedure for award of contracts under this policy shall be as follows:

1.1. In procurement of all items which are divisible in nature, the 'Class I local supplier' shall get purchase preference over 'Class II local supplier' as well as 'Non Local Supplier' as per following procedure:

- i. Among all qualified bids, the lowest bid will be termed as L1. If L1 is 'Class I local supplier', the contract for full quantity will be awarded to L1.
- ii. If L1 bid is not a 'Class I local supplier', 50% of the order quantity shall be awarded to L1. Thereafter, lowest bidder among the 'Class I Local supplier' will be invited to match the L1 price for the remaining 50% quantity subject to the Class I local supplier's quoted price falling within the margin of purchase preference, and contract for that quantity shall be awarded to such 'Class I local supplier' subject to matching the L1 price. In case such lowest eligible 'Class I local supplier' fails to match the L1 price or accepts less than the offered quantity, the next higher 'Class I local supplier' within the margin of purchase preference shall be invited to match the L1 price for remaining quantity and so on, and contract shall be awarded accordingly. In case some quantity is still left uncovered on Class I local suppliers, then such balance quantity may also be ordered on the L1 bidder.

1.2. In the procurement of all items which are not divisible in nature, and in procurement of services where the bid is evaluated on price alone, the 'Class-I local supplier' shall get purchase preference over 'Class-II local supplier' as well as 'Non-local supplier', as per following procedure:

- i. Among all qualified bids, the lowest bid will be termed as L1. If L1 is 'Class-I local supplier', the contract will be awarded to L1.
- ii. If L1 is not 'Class-I local supplier', the lowest bidder among the 'Class-I local supplier', will be invited to match the L1 price subject to Class-I local supplier's quoted price falling within the margin of purchase preference, and the contract shall be awarded to such 'Class-I local supplier' subject to matching the L1 price.
- iii. In case such lowest eligible 'Class-I local supplier' fails to match the L1 price, the 'Class-I local supplier' with the next higher bid within the margin of purchase preference shall be invited to match the L1 price and so on and contract shall be awarded accordingly. In case none of the 'Class-I local supplier' within the margin of purchase preference matches the L1 price, the contract may be awarded to the L1 bidder.



**PROCUREMENT OF VALVES FOR CONFIDENTIAL DEMO PLANT AT
MRPL, MANGALURU, KARNATAKA**

File No.:FP-20013/2/2017-FP-PNG-Part(1) (E-36682)

**Government of India
Ministry of Petroleum and Natural Gas
(Flagship Programme Cell)**

Shastri Bhawan, New Delhi
Date 11th July, 2023

To,

1. Chairman, IOCL
2. CMD, ONGC/ OIL/ BPCL/GAIL/ HPCL/ EIL/ Balmer Lawrie
3. Managing Director, MRPL/ NRL/ CPCL/ BCPL/ OVL
4. DG, DGH
5. DG, PPAC
6. Secretary, OIDB
7. ED, OISD
8. ED, CHT
9. Director, RGIPT/ IPE
10. Secretary, PNGRB
11. CEO & MD, ISPRL

Subject: Public Procurement (Preference to Make in India) Order, 2017: notifying revised Minimum Local Content (MLC) for getting purchase preference and Margin of Purchase Preference (PP) for high value oil and gas LSTK/ EPC contracts/projects- reg.

Reference: MoPNG letter no. FP-20013/2/2017-FP-PNG-Part (4) (E-41432) dated 26.04.2022.

Sir/ Madam,

I am directed to refer to this Ministry's above mentioned letter and to say that in order to increase competition and to incentivize progressive increase in Minimum Local Content in high value oil and gas LSTK/EPC contracts/projects, it has been decided under para 14 of the Public Procurement (Preference to Make in India) Order, 2017, to revise Minimum Local Content (MLC) for getting purchase preference and Margin of Purchase Preference (PP) for such contracts/projects on progressive basis with predictable trajectory.

2. The Minimum Local Content (MLC) for getting purchase preference and Margin of Purchase Preference (PP) for high value oil and gas LSTK/ EPC contracts/projects shall be as under:

Estimated cost		2023-24	2024-26	2026 onwards
Between USD 25 Million to USD 50 Millions	MLC	50%	50%	50%
	PP	10%		
Between USD 50 Millions to USD 100 Millions	MLC	30%	50%	50%
	PP	10%		

Handwritten signature
11/07/23



**PROCUREMENT OF VALVES FOR CONFIDENTIAL DEMO PLANT AT
MRPL, MANGALURU, KARNATAKA**

Estimated cost		2023-24	2024-26	2026 onwards
Between USD 100 Millions to USD 150 Millions	MLC	30%	35%	50%
	PP	10%		
More than USD 150 Millions	MLC	30%	30%	35%
	PP	10%		

3. This issues with the approval of Hon'ble Minister, P&NG.

Yours faithfully

(Kapil Kumar)

Under Secretary to the Govt. of India

Tel.:011-23383074

Copy to,

- a. PS to Hon'ble Minister, P&NG
- b. PS to Hon'ble MoS, P&NG
- c. PPS/PS to Secretary, P&NG
- d. PPS/PS to AS&FA/ AS, MoPNG
- e. PPS/PS to JS(E&BR)/ JS (M&OR)/ JS (IC)/ JS (G)/ JS (IFD)/ DDG, MoPNG
- f. Technical Director, NIC: with request to upload the letter on MoPNG website

Copy for information to,

Secretary, DPIIT



**PROCUREMENT OF VALVES FOR CONFIDENTIAL DEMO PLANT AT
MRPL, MANGALURU, KARNATAKA**

No.F.1/4/2021-PPD
Government of India
Ministry of Finance
Department of Expenditure
Public Procurement Division

264-C, North Block, New Delhi.
18.05.2023.

OFFICE MEMORANDUM

Subject: Concurrent application of Public Procurement Policy for Micro and Small Enterprises Order, 2012 and Public Procurement (Preference to Make in India) Order, 2017.

The undersigned is directed to refer two Preferential Procurement Orders mandated for the Public Procurement in India, namely:

- i. Public Procurement Policy for Micro and Small Enterprises (MSEs) Order dated 23.03.2012 (PPP-MSE Order) issued by Ministry of Micro, Small and Medium Enterprises (MoMSME) in exercise of the powers conferred in Section 11 of the MSME Development Act, 2006. (Last revised on 09.11.2018)
- ii. Public Procurement (Preference to Make in India) Order, 2017 (PPP-MII order), under Rule 153(iii) of the General Financial Rules (GFRs) 2017, approved by the Cabinet. Implementation of this PPP-MII order is monitored by Department for Promotion of Industry and Internal Trade (DPIIT). (Last revised on 16.09.2020.)

2. It has been brought to the notice of this Department that concurrent application of these two orders are creating confusion to the procuring entities and different procuring entities interpret them differently. In order to bring predictability both to the procuring entities as well as bidders, following guidelines are being issued.

Guidelines

3. The Class-I local suppliers, under PPP-MII Order, participating in any government tender, may or may not be MSEs, as defined under the MSME Act. Similarly, MSEs participating in any government tender, may or may not be Class-I local suppliers. Suppliers may be categorised in following four broad categories for consideration or applicability of purchase preference:

Category	Terminology
Supplier is both MSE & Class-I local supplier.	"MSE Class-I local supplier"
Supplier is MSE but not Class-I local supplier.	"MSE but non-Class-I local supplier"
Supplier is not MSE but is Class-I local supplier.	"Non-MSE but Class-I local supplier"
Supplier is neither MSE nor Class-I local.	"Non-MSE non-Class-I local supplier"



**PROCUREMENT OF VALVES FOR CONFIDENTIAL DEMO PLANT AT
MRPL, MANGALURU, KARNATAKA**

4. The applicability of PPP-MSE Order and PPP-MII Order in various scenarios, involving simultaneous purchase preference to MSEs and Class-I local suppliers under PPP-MSE Order and PPP-MII Order respectively, shall be as under:

- a) *Items covered under Para 3(a) of PPP- MII Order, 2017 for which Nodal Ministry has notified sufficient local capacity and competition:* For these items, only Class-I local suppliers are eligible to bid irrespective of purchase value. Hence, Class-II local suppliers or Non-local suppliers, including MSEs which are Class-II local suppliers/ Non-local suppliers, are not eligible to bid. Possible scenarios can be as under:
- (i) L-1 is "MSE Class-I local supplier" - 100% of the tendered quantity is to be awarded to L-1.
 - (ii) L-1 is "Non-MSE but Class-I local supplier" - Purchase preference is given to MSEs as per PPP-MSE Order. Balance quantity is to be awarded to the L-1 bidder.
- b) *Items reserved exclusively for procurement from MSEs as per PPP-MSE Order:* These items are reserved exclusively for purchase from MSEs. Hence, non-MSEs are not eligible to bid for these items. Possible scenarios can be as under:
- (i) L-1 is "MSE Class-I local supplier" - 100% of the tendered quantity is to be awarded to L-1.
 - (ii) L-1 is "MSE non-Class-I local supplier" - Purchase preference is to be given to Class-I local supplier as per PPP-MII Order. Balance quantity, is to be awarded to L-1 bidder.
- c) *If items are neither notified for sufficient local capacity nor reserved for MSEs, then the process will be as follows:*
- c (a) Items covered under Para 3A(b) of PPP-MII Order are divisible items and both MSEs as well as Class-I local suppliers are eligible for purchase preference. Possible scenarios can be as under:
- (i) L-1 is "MSE Class-I local supplier" - 100% of the tendered quantity is to be awarded to L-1.
 - (ii) L-1 is "Non-MSE but Class-I local supplier" - Purchase preference is to be given to MSEs, if eligible, as per PPP-MSE Order. Balance quantity is to be awarded to L-1 bidder.
 - (iii) L-1 is "MSE but non-Class-I local supplier" - Purchase preference is to be given to Class-I local suppliers, if eligible, as per PPP-MII Order. Balance quantity is to be awarded to L-1 bidder.
 - (iv) L-1 is "Non-MSE non-Class-I local supplier" - Purchase preference is to be given to MSEs as per PPP-MSE Order. Thereafter, purchase preference is to be given to Class-I local suppliers for "50% of the tendered quantity minus quantity allotted to MSEs



**PROCUREMENT OF VALVES FOR CONFIDENTIAL DEMO PLANT AT
MRPL, MANGALURU, KARNATAKA**

above" as per PPP- MII Order. For the balance quantity, contract is to be awarded to L-1 bidder. *(Kindly refer to the illustrative example in the annexure).*

c (b) Items covered under Para 3A(c) of PPP-MII Order, 2017 are non-divisible items and both MSEs as well as Class-I local suppliers are eligible for purchase preference. Possible scenarios can be as under:

- (i) L-1 is "MSE Class-I local supplier" - Contract is awarded to L-1.
- (ii) L-1 is not "MSE Class-I local supplier" but the "MSE Class-I local supplier" falls within 15% margin of purchase preference - Purchase preference is to be given to lowest quoting "MSE Class-I local supplier". If lowest quoting "MSE Class-I local supplier" does not accept the L-1 rates, the next higher "MSE Class-I local supplier" falling within 15% margin of purchase preference is to be given purchase preference and so on.
- (iii) If conditions mentioned in sub paras (i) and (ii) above are not met i.e. L-1 is neither "MSE Class-I local supplier" nor "MSE Class-I local supplier" is eligible to take benefit of purchase preference, the contract is to be awarded/ purchase preference to be given in different possible scenarios as under:

- A. L1 is "MSE but non-Class-I local supplier" or "Non-MSE but Class-I local supplier" – Contract is awarded to L1.
- B. L1 is "Non-MSE non-Class-I local supplier" - First purchase preference to be given to MSE as per PPP-MSE Order. If MSE not eligible/ does not accept - purchase preference to be given to Class- I Local supplier as per PPP-MII Order. If Class-I Local supplier also not eligible/ does not accept – contract to be awarded to L-1.

d) *Items reserved for both MSEs and Class-I local suppliers:* These items are reserved exclusively for purchase from MSEs as well as Class-I local suppliers. Hence, only "MSE Class-I local supplier" are eligible to bid for these items. Non-MSEs/Class-II local suppliers/ Non-local suppliers cannot bid for these items. Hence the question of purchase preference does not arise.

e) Non-local suppliers, including MSEs falling in the category of Non-local suppliers, shall be eligible to bid only against Global Tender Enquiry.

18/5/2023
(Kanwalpreet)
Director

Tel.: -223093811; email: - kanwal.irss@gov.in

To

1. Secretaries of all Central Government Ministries/ Departments.
2. Secretary Department of Public Enterprises with a request for issuing suitable instructions to all Central Public Sector Enterprises in this regard.

Page 3 of 4



**PROCUREMENT OF VALVES FOR CONFIDENTIAL DEMO PLANT AT
MRPL, MANGALURU, KARNATAKA**

Annexure

Example explaining applicability in scenario explained in para 4 c (a)(iv)

(Scenario: Divisible items, both MSEs as well as Class-I local suppliers eligible for purchase preference and L-1 is "Non-MSE non-Class-I local supplier")

Item – Desktop computer

Qty – 50 Nos.

Details of bids received

Sr. No.	Name of bidder	Rates quoted	Price Ranking	Status of bidder
1.	A	100	L1	"Non-MSE non- Class-I local supplier"
2.	B	110	L2	"Non-MSE but Class-I local supplier"
3.	C	112	L3	"MSE but non- Class-I local supplier"
4.	D	115	L4	"Non-MSE but Class-I local supplier"
5.	E	118	L5	"MSE but non- Class-I local supplier"
6.	F	120	L6	"MSE Class-I local supplier"

1. In this case, first purchase preference is to be given to MSEs as per PPP-MSE Order for 25% of tendered quantity of 50 Nos. i.e. 12.5 Nos. (rounded off to the next whole number say 13 Nos). Accordingly, invite L3 (bidder C), whose quoted rates falls within 15% margin of purchase preference to match L1 price i.e. Rs. 100/- for quantity of 13 Nos. Bidder "E" and "F", although MSEs, will not get purchase preference since their quoted rates don't fall within 15% margin of purchase preference. Bidder C will be considered for order of 13 Nos. on confirmation of reduction of price.
2. For 50% of balance quantity of 37 number (tendered quantity of 50 – 13 awarded to bidder C; assuming bidder C has confirmed to accept L1 rates), purchase preference will be given to lowest Class-I local supplier as per PPP-MII Order. Accordingly, bidder B will be invited to match L-1 price for 50% of 37 Nos i.e. 18.5 (say 19 Nos of computers). If bidder "B" does not accept the L1 price i.e. price of Rs. 100/- per unit, next higher Class-I local supplier falling within 20% margin of purchase preference, i.e. bidder "D", may be invited to match L-1 price for 19 Nos. of computers and so on.
3. For remaining quantity i.e. 18 Nos (50-13-19), the contract will be awarded to lowest quoting bidder i.e. Bidder "A", who is L-1 in the example.



**PROCUREMENT OF VALVES FOR CONFIDENTIAL DEMO PLANT AT
MRPL, MANGALURU, KARNATAKA**

28.0 TERMS AND CONDITIONS FOR BIDDERS FROM A COUNTRY SHARING LAND BORDERS WITH INDIA

- I. The Department of Expenditure (Ministry of Finance) of the Govt. Of India through OMs no. 6/18/2019- PPD dated 23rd July and 24th July'2020 has issued guidelines regarding procurement from bidders from a country or countries which share land boundary with India. The detail guidelines are available on the website of DoE (<https://doe.govin/>).
- II. Any bidder from a country which shares a land border with India will be eligible to bid in this tender only if the bidder is registered with the Competent Authority specified in Annexure I of the DoE OM dated 23.07.2020 (attached for reference). The Competent authority for the purpose of registration shall be the Registration Committee constituted by the Department of Promotion of industry & internal Trade (DPIIT) of Govt. of India.
- III. "Bidder" (including the term 'tenderer', 'consultant' or 'service provider' in certain contexts) means any person or firm or company, including any member of a consortium or joint venture (that is an association of several persons, or firms or companies), every artificial juridical person not falling in any of the descriptions of bidders stated hereinbefore, including any agency branch or office controlled by such person, participating in a procurement process.
- IV. "Bidder from a country which shares a land border with India" for the purpose of this Order means:-
 - a) An entity incorporated, established or registered in such a country; or
 - b) A subsidiary of an entity incorporated, established or registered in such a country; or
 - c) An entity substantially controlled through entities incorporated, established or registered in such a country; or
 - d) An entity whose beneficial owner is situated in such a country; or
 - e) An Indian (or other) agent of such an entity; or
 - f) A natural person who is a citizen of such a country; or
 - g) A consortium or joint venture where any member of the consortium or joint venture falls under any of the above
- V. The beneficial owner for the purpose of (iii) above will be as under:
 1. In case of a company or Limited Liability Partnership, the beneficial owner is the natural person(s), who, whether acting alone or together, or through one or more juridical person, has a controlling ownership interest or who exercises control through other means.



**PROCUREMENT OF VALVES FOR CONFIDENTIAL DEMO PLANT AT
MRPL, MANGALURU, KARNATAKA**

Explanation-

- a) "Controlling ownership interest" means ownership of or entitlement to more than twenty-five per cent. of shares or capital or profits of the company,
- b) "Control" shall include the right to appoint majority of the directors or to control the management or policy decisions including by virtue of their shareholding or management rights or shareholders agreements or votings agreements.

2. In case of a partnership firm, the beneficial owner is the natural person(s) who, whether acting alone or together, or through one or more juridical person, has ownership of entitlement to more than fifteen percent of capital or profits of the partnership.

3. In case of an unincorporated association or body of individuals, the beneficial owner is the natural person(s), who, whether acting alone or together, or through one or more juridical person, has ownership of or entitlement to more than fifteen percent of the property or capital or profits of such association or body of individuals;

4. Where no natural person is identified under (1) or (2) or (3) above, the beneficial owner is the relevant natural person who holds the position of senior managing official;

5. In case of a trust, the identification of beneficial owner(s) shall include identification of the author of the trust, the trustee, the beneficiaries with fifteen percent or more interest in the trust and any other natural person exercising ultimate effective control over the trust through a chain of control or ownership.

- V. An Agent is a person employed to do any act for another, or to represent another in dealings with third person.
- VI. In tenders for Works Contracts, including Turnkey contracts - The successful bidder shall not be allowed to sub-contract works to any contractor from a country which shares a land border with India unless such contractor is registered with the Competent Authority.
- VII. Bidder mandatorily requires to submit "Certificate of Compliance" in the enclosed Form : A. This certificate need to be submitted in the Company's Letter Head and should be sealed and signed by the authorized signatory on behalf of the bidder. None submission of Form A may lead to disqualification for Techno- Commercial evaluation of the submitted bid. (Refer Form B in case of Works Contract).

In case at any stage pre or post order placement it is found that that the certification furnished is false their bid shall be summarily rejected or order terminated as applicable. MRPL may at its discretion initiate penal action against such bidders which may include Black Listing Holiday Listing the party /encashment of EMD or PBG submitted as per contractual provision etc.

- VIII. Compulsory submission of Valid Registration Certificate from Competent Authority is required as and when a party claims to have registered themselves with the Competent Authority or else bid shall be rejected without evaluation.



**PROCUREMENT OF VALVES FOR CONFIDENTIAL DEMO PLANT AT
MRPL, MANGALURU, KARNATAKA**

IX. Wherever Tenders are floated Registration with Competent Authority should be valid at the time of submission of Bid and at the time of acceptance and evaluation of bids / LOA or Order Placement. In case where tender is not floated registration should be valid at the time of placement of Order. A Bidder who is validly registered at the time of acceptance / placement of order in such cases valid registration will not be a relevant consideration during contract execution.

Note I: For better clarity and to obtain information in detail bidders are requested to go thru the Govt Circular issued by the Department of Expenditure Govt of India to this effect.

Note II: For information on Exclusion from restriction under Rule 144 (xi) of the GFR, 2017 and Special Cases for exemption under the purview of this policy, bidders are requested to refer to the Govt Circular & Annexures therein accordingly.

Special Note: It is the responsibility of the Bidders to keep themselves updated over any revisions or changes in conditions mentioned in this circular. For all practical purpose the latest applicable circular will be considered for this tender as published by the Govt time to time.



**PROCUREMENT OF VALVES FOR CONFIDENTIAL DEMO PLANT AT
MRPL, MANGALURU, KARNATAKA**

FORM A

BIDDER's UNDERTAKING

(On Company's Letter Head)

To,
Mangalore Refinery & Petrochemicals Limited
Mangaluru, Karnataka.

Sub: Certificate of Compliance

Bidder's Details :

Name of the Tender : _____

Tender No : _____

We/ I have read carefully the clause regarding restrictions on procurement from a bidder of a country which shares land boundary with India attached with this Tender Document and hereby certify that M/s. _____ (Name of the Company/ Bidder) is :-

A. Not from such a country and is eligible to be considered for evaluation : YES / NO (*)

B. (i) If from such a country but is registered with the Competent Authority: YES/NO (*)

C. (ii) If from such a country valid Registration Certificate from Competent Authority is submitted with the bid : YES / NO (*)

I as the authorized signatory on behalf of the bidder certify that the company fulfils all the criteria stipulated in the Govt OM and is eligible to be considered for this tender.

(*) : Tick Yes / No whichever is applicable.

Place : Signature :

Date : Name :

Designation :

Seal of the Company :



**PROCUREMENT OF VALVES FOR CONFIDENTIAL DEMO PLANT AT
MRPL, MANGALURU, KARNATAKA**

FORM B

BIDDER'S UNDERTAKING IN CASE OF WORKS CONTRACT

(On Company's Letter Head)

To,
Mangalore Refinery & Petrochemicals Limited
Mangaluru, Karnataka.
Sub: Certificate of Compliance

Bidder's Details:

Name of the Tender : _____
Tender No : _____

We / I have read carefully the clause regarding restrictions on procurement from a bidder of a country which shares land boundary with India attached with this Tender Document and on sub-contracting to contractors from such countries and hereby certify that M/s. _____ (Name of the Company/ Bidder) is :-

- A. Not from such a country and is eligible to be considered for evaluation : YES / NO (*)
- B. (i) If from such a country but is registered with the Competent Authority : YES/NO (*)
- C. (ii) If from such a country valid Registration Certificate from Competent Authority is submitted with the bid : YES / NO (*)

M/s. _____ (Name of the Company) certify that we will not sub-contract any work to a party/ contractor from such countries unless they are registered with the Competent Authority.

I as the authorized signatory on behalf of the bidder certify that the company fulfils all the criteria stipulated in the Govt OM and is eligible to be considered for this tender.

(*) : Tick Yes / No whichever is applicable.

Place: _____ Signature : _____

Date: _____ Name : _____

Designation : _____

Seal of the Company : _____



**PROCUREMENT OF VALVES FOR CONFIDENTIAL DEMO PLANT AT
MRPL, MANGALURU, KARNATAKA**

FORM C
BIDDER's UNDERTAKING (For Transitional Cases)
(On Company's Letter Head)

To,
Mangalore Refinery & Petrochemicals Limited
Mangaluru, Karnataka.

Sub: Certificate of Compliance

Bidder's Details:

Name of the Tender : _____

Tender No : _____

We/I have read carefully the clause regarding restriction on procurement from a bidder of a country which shares land boundary with India attached with this tender document and hereby certify that M/s. _____ (Name of the Company) is not from such a country and is eligible to be considered.

We/I do solemnly resolve to submit valid registration certificate from Competent Authority as applicable in case any such requirement arises for evaluation and acceptance of bid purpose.

Place: _____ Signature : _____

Date: _____ Name : _____

Designation : _____

Seal of the Company : _____



**PROCUREMENT OF VALVES FOR CONFIDENTIAL DEMO PLANT AT
MRPL, MANGALURU, KARNATAKA**

- 29.0 **TERMS & CONDITIONS OF SUPERVISION OF ERECTION, TESTING & COMMISSIONING) (IF APPLICABLE AS PER TECHNICAL SPECIFICATION) Refer attached Annexure – A.**
- 30.0 **TERMS & CONDITIONS OF POST WARRANTY COMPREHENSIVE ANNUAL MAINTENANCE CONTRACT (PWCAMC) (IF APPLICABLE AS PER TECHNICAL SPECIFICATION)
Refer attached Annexure – B.**
- 31.0 **TERMS & CONDITIONS OF TRAINING OF EMPLOYER’S PERSONNEL AT MANUFACTURER’S WORKS/ FACILITIES (IF APPLICABLE AS PER TECHNICAL SPECIFICATION)
Refer attached Annexure – C.**
- 32.0 **TERMS & CONDITIONS FOR SITE WORK (IF APPLICABLE AS PER TECHNICAL SPECIFICATION)
Refer attached Annexure – D.**
- 33.0 **Procedure for Final Documentation (SPC-000009) (Rev.-01)
Refer attached Annexure - E**
- 34.0 **Vulnerability Atlas of India
Refer attached Annexure - F**



**PROCUREMENT OF VALVES FOR CONFIDENTIAL DEMO PLANT AT
MRPL, MANGALURU, KARNATAKA**

ANNEXURE – A TO SPC

**TERMS & CONDITIONS FOR SUPERVISION OF ERECTION, TESTING &
COMMISSIONING (If Applicable):**

1. Bidder shall quote per diem charges which shall include lodging, boarding, To & fro air fare upto Mangaluru, medical, local transportation, all insurances including Bidder's personnel and third party insurance, all other incidental charges and all taxes / duties / cess / levies / fees, etc. except GST (for bidders registered in India) which shall be quoted extra and shall be payable against submission of Invoice as per GST Invoicing rules.
2. Tax(s) as per Government policy shall be deducted at source by Purchaser while making payments against each invoice.
3. **Per diem charges shall be payable from the day bidder's person reaches site upto the day he leaves the site. No payment will be made for travel days/period.**
4. **In case bidder's representative is not called for during Intervening weekly off/Holidays, the same shall be payable at the normal rate of site services. However, in case Seller's representative is called at site during weekly off/Holiday, the same shall be paid @ overtime rate quoted extra by bidder.**
5. **In case bidder's representative takes leave, per diem charges for that day shall not be payable.**
6. **Working hours prevailing at site, normally 8 hours/day - Monday through Saturday and holidays as applicable to Purchaser's site personnel shall apply.**
7. **Selection of Foreign/ Indian supervisory personnel shall be left to Owner's/Purchaser's choice.**
8. **Vendor's supervisory personnel shall observe/abide by site working conditions prevailing at the existing site, safety codes, Indian laws and local laws.**
9. **A notice period of 15 days will be given for mobilization of supervisory personnel for supervision of erection.**
10. **Validity period of per diem rate shall be upto the end of guarantee period. Further, in case services for supervision are required after the guarantee period, suitable escalation shall be as per mutually agreed terms.**
11. **Payment: 100% against submission of monthly bills and time sheets certified by the Engineer-in-Charge.**
12. **Requirement of Employment Visa for Foreign Nationals**

All foreign nationals coming to India for execution of Projects / Orders will have to apply for Employment Visa only and that grant of Employment Visa would be subject to strict adherence of following norms:

- i) Employment Visa is granted only for the skilled and qualified professional or to a person who is being engaged or appointed by a company, organization, Industry or undertaking etc. in India on contract or employment basis at a senior level, skilled position such as technical expert, senior executive or in managerial position etc.
- ii) Request for employment Visa for jobs for which large number of qualified Indian are available, is not considered.



**PROCUREMENT OF VALVES FOR CONFIDENTIAL DEMO PLANT AT
MRPL, MANGALURU, KARNATAKA**

- iii) Under no circumstances an Employment Visa is granted for routine, ordinary secretarial / clerical jobs.

Bidders are advised in their own interest to check latest Visa rules from Indian Embassy/ High Commission in their country in case foreign nationals are required to be deputed to Indian during execution of the Order.

CHARGES FOR SUPERVISION OF ERECTION/TESTING/COMMISSIONING:

S. No.	Description	Vendor's Reply/Information (_____) Currency
1.	Per diem charges (per person) for 8 hours work on normal working days (Monday to Saturday)	To be Quoted in Price Schedule
2.	Overtime rate/ hour beyond normal 8 hours work on normal working days.	
3.	Overtime rate/hour for work on Sundays/ holidays (as applicable at Project site).	
4.	Applicable Rate of GST	

Notes:

1. In case bidder recommends more than one category level of supervisory personnel the information desired at Sr. Nos.1 to 4 above in the table shall be furnished separately for each category of supervisory personnel.
2. Quoted per diem rate shall be considered in the evaluation as per TENDER Document.

Bidder's Acceptance:

TENDER No. :

Signature with Name & Date and

Item :

Seal/Stamp of the Bidder

Offer No. :



**PROCUREMENT OF VALVES FOR CONFIDENTIAL DEMO PLANT AT
MRPL, MANGALURU, KARNATAKA**

ANNEXURE – B TO SPC

**TERMS & CONDITIONS FOR POST WARRANTY COMPREHENSIVE ANNUAL
MAINTENANCE CONTRACT (If Applicable):**

- a) Please quote for the Post Warranty Annual Maintenance Contract as per scope defined in Technical Specification. Please furnish the year wise Break-up in the Price Schedule.
- b) The AMC Charges quoted in Price Schedule Format shall be inclusive of all the charges for Transportation, Lodging, Boarding, all insurances including third party insurance, all Taxes / Duties / Cess / Levies / Fees and all other incidental charges etc. but excluding GST which shall be payable extra at actual on Submission of Invoice as per GST Invoicing rules. Owner will not have any liability, whatsoever, over and above the quoted prices.
- c) The payment terms for the AMC shall be on quarterly basis after completion of each quarter against submission of Bills duly certified by the Engineer-in-charge.
- d) The order for AMC will be placed before the expiry of contractual Warranty Period. The price of AMC services will remain firm & fixed for the complete execution of AMC contract. In case there is delay in start of AMC from the date of expiry of warranty period, the charges shall be paid on pro-rata basis for the duration curtailed from original specified AMC period.
- e) Within 2 weeks of placement of Order for AMC, Seller shall submit CPBG for 3% of the Maximum annual AMC amount which shall be valid for the entire AMC period plus 2 months claim period.
- f) Periodic and Preventive maintenance: Vendor shall depute their engineers to installation site as & when required for regular check-ups, as part of periodic maintenance. Vendor shall also depute their service engineers periodically for preventive maintenance, major repairs / replacement and reporting. Price shall also include emergency visits as necessary.
- g) Scope of AMC shall be as per Technical Specification. The quoted lump-sum rate shall include providing all manpower, machineries and materials, including any special tools & tackles required required to carry out the work as per scope of work of AMC defined in the Technical Specification.



**PROCUREMENT OF VALVES FOR CONFIDENTIAL DEMO PLANT AT
MRPL, MANGALURU, KARNATAKA**

ANNEXURE – C TO SPC

**TERMS & CONDITIONS FOR TRAINING OF EMPLOYER'S PERSONNEL
AT MANUFACTURER'S WORKS/ FACILITIES (IF APPLICABLE AS PER TECHNICAL SPECIFICATION)**

1. Bidder shall quote Training charges of OWNER's operation and Maintenance personnel at Bidder's works/ training facility on lump-sum basis for each trainee.
2. Economy class Air fare, accommodation & local conveyance shall be reimbursed at actuals, by owner
3. Quoted prices shall be inclusive of all taxes / duties / cess / levies / fees / etc. except GST which shall be payable extra at actuals against submission of documents as per GST Invoicing rules.
4. A notice period of 15 days will be given by Owner for prior arrangement.
5. PAYMENT TERMS: 100% on completion of services against submission of invoice, any other supporting documents, if required along with Certificate duly certified by Engineer-in-charge



**PROCUREMENT OF VALVES FOR CONFIDENTIAL DEMO PLANT AT
MRPL, MANGALURU, KARNATAKA**

ANNEXURE – D TO SPC

TERMS & CONDITIONS FOR SITE WORK (IF APPLICABLE):

1. The Vendor shall perform their jobs in eco-friendly manner and in consonance with the objectives of MRPL Refinery environment management system.
2. Construction / erection work for several other project facilities at various locations within refinery site will be progressing concurrently. It will be the responsibility of vendor to seek approvals from the Owner/Purchaser for working within & outside the refinery limits and also of taking all suitable safety measures as per regulations in force for the safety of existing-refinery.
3. The material shall be collected by the vendor from Purchaser's stores/Project Site/vendor's own stores (as the case may be) and transported to the erection site at Vendor's cost and risk.
4. All labour (both skilled and unskilled), tools, tackles and consumables etc. shall be arranged by Vendor at his own cost.
5. Vendor shall arrange for the necessary transport, accommodation, medical, canteen and other facilities for their employees / staff at their own cost and abide by all labour laws, safety codes and statutory regulations and keep Owner/ Purchaser indemnified in respect thereof.
6. Purchaser shall arrange the Marine cover Insurance and Erection All Risk (EAR) Cover Insurance for the project for permanent incorporation of material and services. Vendor shall arrange and pay for all other insurances as may be required under the law for their employees / materials / subcontractor(s). Vendor shall be working at Owner's site along with agencies that will be engaged in the other activities. For this purpose the third party risk shall also be covered by Vendor.
7. The Vendor is responsible for keeping his work place neat and clean and shall always avoid scattering of any materials around the work place. The Vendor shall clear the work site of all debris, materials, tools, tackles etc. immediately upon completion of the job. Any temporary pipeline / cables etc. laid for the purpose of execution of a particular job shall be immediately removed to an agreed location and the site cleared off all such materials.
8. The Vendor shall not throw out gaskets, used electrode pieces, hand gloves, cotton wastes, gunny bags, polythene bags etc. into open channel, any drains or pipe line system. These are to be collected together and deposited in bins/waste collectors earmarked for the purpose of disposal after consultation with Engineer-in-Charge.
9. **Water & Power**
 - 9.1 WATER
Construction water shall not be provided by Owner/Purchaser. However Water for Hydrotest & pre-commissioning/ commissioning shall be provided on free of charge basis, based on availability.
 - 9.2 POWER



**PROCUREMENT OF VALVES FOR CONFIDENTIAL DEMO PLANT AT
MRPL, MANGALURU, KARNATAKA**

Owner will provide power on chargeable basis, at one point from where Contractor shall make his own arrangement for temporary distribution. All the works will be done as per IEA regulation and checked & passed by Owner. The temporary line will be removed after the completion of work or if there is any hindrance caused to the other works due to alignment of these lines, Contractor shall re-route or remove the temporary lines at his own cost. Contractor at his own cost shall also provide suitable electric meters, fuses, switches etc. which should be in custody of Engineer-in-charge.

In case Owner/Purchaser is unable to provide the power, Contractor shall make his own arrangement.

9.3 If Owner / Purchaser is unable to provide water as mentioned above for any reasons whatsoever, the same have to be arranged by Contractor at their own cost. No time extension shall be payable on the above account. This shall not relieve Contractor of his responsibility for timely completion of the work as stipulated in the bidding document.

10. MRPL may permit the bidder, reasonably required land (subject to availability), free of any liability to establish a temporary site office, fabrication yard and storage area at the job site, at the discretion of Engineer-in-charge. MRPL shall not permit any land at site to be used for residential purposes nor shall otherwise provide or arrange any land for temporary accommodation of the bidder's personnel or labour.

The bidder shall at its own cost and initiative arrange land for residential accommodation for its staff and workers and the quoted price shall be deemed to include the same.

11. All Cranes, handling equipment etc. as required, shall be arranged by Vendor at his cost.

12. As per the applicable Factory Act the Labour License, if required, shall be taken by Vendor before starting the works.

13. All necessary compliances to various statutory requirements including Factories Act, Labour Welfare legislations etc. shall be vendor's responsibility.

14. It shall be vendor's responsibility to comply with all rules and regulations in force at construction site.

15. Surplus material, if any, after completion of site work, shall not be allowed to be taken out of Project Site, on case to case basis.

16. TAXES & DUTIES

16.1 Foreign vendor's quoted prices shall be inclusive of Indian Income Tax/ withholding Tax and Indian vendor's quoted prices shall be inclusive of Indian Income Tax.

16.2 Quoted prices shall be Exclusive of GST on Site Work, the same shall be paid extra at actuals against submission of Invoices as per GST Invoicing rules.

16.3 Necessary tax registration, if any, for site activity shall be done by vendor and cost shall be included in the quoted price.



**PROCUREMENT OF VALVES FOR CONFIDENTIAL DEMO PLANT AT
MRPL, MANGALURU, KARNATAKA**

17. REQUIREMENT OF EMPLOYMENT VISA FOR FOREIGN NATIONALS

All foreign nationals coming to India for execution of Projects / Orders will have to apply for Employment Visa only and that grant of Employment Visa would be subject to strict adherence of following norms:

- 17.1 Employment Visa is granted only for the skilled and qualified professional or to a person who is being engaged or appointed by a company, organization, Industry or undertaking etc. in India on contract or employment basis at a senior level, skilled position such as technical expert, senior executive or in managerial position etc.
- 17.2 Request for employment Visa for jobs for which large number of qualified Indian are available, is not considered.
- 17.3 Under no circumstances an Employment Visa is granted for routine, ordinary secretarial / clerical jobs.
- 17.4 Bidders are advised in their own interest to check latest Visa rules from Indian Embassy/ High Commission in their country in case foreign nationals are required to be deputed to Indian during execution of the Order.



**PROCUREMENT OF VALVES FOR CONFIDENTIAL DEMO PLANT AT
MRPL, MANGALURU, KARNATAKA**

ANNEXURE – E TO SPC

Procedure for Final Documentation (SPC-000009) (Rev.-01)



PROCUREMENT OF VALVES FOR CONFIDENTIAL DEMO PLANT AT
MRPL, MANGALURU, KARNATAKA

	MANGALORE REFINERY AND PETROCHEMICALS LIMITED
	PROCEDURE FOR FINAL DOCUMENTATION
	SPC00009 Rev.1



1	01/12/2020	Revised and Reissued			
0	01/09/2015	Revised, Renumbered and Reissued			
Rev No	Rev Date	Description	Prepared By	Checked By	Approved By

SPC00009	1	00000000000000000000000000000000	Page 1 of 3
Doc. No.	Ed.	SAP-DMS-DIR	PAGE



**PROCUREMENT OF VALVES FOR CONFIDENTIAL DEMO PLANT AT
MRPL, MANGALURU, KARNATAKA**

	MANGALORE REFINERY AND PETROCHEMICALS LIMITED
PROCEDURE FOR FINAL DOCUMENTATION	SPC00009 Rev.1

1. OBJECTIVE

- 1.1 This procedure provides general guidelines to compile and submit the Final Documents to MRPL by the agency is executing specific job against a W.O. or a P.O. issued by MRPL or by any agency on behalf of MRPL
- 1.2 Final Document as per these guidelines shall be prepared *in addition* to the documents issued during project execution (construction documents), which is normally released in parts while the job is in progress.
- 1.3 This is a general guideline for all projects of MRPL, however any addition or deletion of the clauses based on the specific project requirement shall be approved by PMC or the Engineer-in-charge of MRPL. An approved deviation note shall be furnished for this purpose.

2. COMPONENTS OF THE FINAL DOCUMENTS

2.1 BASIC DESIGN & EXTENDED BASIC DESIGN PACKAGES

Basic and extended design packages shall be compiled and the revision control shall be maintained by the respective PMC or the similar agency of the project. At the completion of the project complete and updated sets of design packages with all latest revisions shall be handed over to MRPL. Similarly Basic Engineering Design Basis for unit & facilities shall be handed over to MRPL.

2.2 MASTER INDEX FOR DOCUMENTS & DRAWINGS

- 2.2.1 These shall be treated as a key document for reviewing completeness of the documentation at any point of time. It shall show details of documents/ drawing applicable for any equipment / system / service. Master Drawing/Document Index shall have following columns :-

Unit	Job/PO No	Folder No.	Sr. No.	Drw./Doc. No.	Rev.	No of Sheets		Equip. No	Drawing /Doc Title	Remarks
						From	To			

Rev	Date	Prepared by	Checked by	Approved by PMC/Consultant	Approved by MRPL

- 2.2.2 A detailed list of PO/Contract to be furnished to MRPL Engineering Documentation Centre to ensure that documentation of equipment / contract is/are submitted in totality.

SPC00009	1	1000183908	Page 2 of 8
Doc. No.	Rev	SAP/DMS/DIR	PAGE



**PROCUREMENT OF VALVES FOR CONFIDENTIAL DEMO PLANT AT
MRPL, MANGALURU, KARNATAKA**

	MANGALORE REFINERY AND PETROCHEMICALS LIMITED	
	PROCEDURE FOR FINAL DOCUMENTATION	SPC00009 Rev.1

2.2.3 A complete list of drawings and documents including document control index to be submitted *in addition to clause 2.2.1.*

2.3 SECTIONS OF THE FINAL VENDOR/ENGINEERING DOCUMENT FOLDER

2.3.1 Section A : Contents

Shall have following columns:-

Sr. No.	Drawing No.	Rev.	No of Sheet	Equipment	Drawing Title	Digital file name (SOFTCOPY)

This content to be certified by the PMC/Consultant/Engineer-in-charge of MRPL for its completeness in all respects.

2.3.2 Section B : Technical Documents/Drawings

Followings are the various subsections

Sr no.	Documents
Vendor requirement	
1	Detailed technical with PR / Engineering Specification / Design Basis / Design Calculation/Sizing calculation
2	Equipment list.
3	As-Built Specification sheet / data sheet, Performance Curve
4	General arrangement drawing, Cross Sectional drawing, Part Drawing
5	Assembly drawing, Fabrication, structural & foundation drawing
6	Foundation Information Document for Foundation Design
7	Drawings / catalogues, for special items like spring/hangers/ expansion bellows etc
8	Instrument/Electrical system all documents
9	Details documents & drawings, Data sheet, Manual & Catalogues of Bought-out Component,
10	Guarentee certificate, Inspection release note in original
Engineering requirement	
11	Flow Sheet & summaries (System Drawing, P&IDS, Utility Flow Dia., Material flow diagram), Utility and Chemical Consumption Data
12	Layout Drawing, Piping, Civil, Structural general arrangement Drawing
13	Instrument/Electrical specifications, data sheets & drawings
14	Line schedule, Stress analysis documents.

SPC00009	1	1000183908	Page 3 of 8
Doc. No.	Rev	SAP/DMS/DIR	PAGE



**PROCUREMENT OF VALVES FOR CONFIDENTIAL DEMO PLANT AT
MRPL, MANGALURU, KARNATAKA**

	MANGALORE REFINERY AND PETROCHEMICALS LIMITED
PROCEDURE FOR FINAL DOCUMENTATION	SPC00009 Rev.1

15	Under ground piping, OWS & CRWS drawings along with standard & specification.
16	Piping material specification, Valve material specification
17	Pipe Support drawings / Standards, Lubricants List
18	Line wise bill of materials and summary
19	Process and mechanical Design / Strength calculations, Hazop report, Stress analysis report.
20	Any other documents like Fire fighting system, soil investigation, survey documents, Statutory documents etc.

2.3.3 Section C : Manual / Procedures

Sr no.	Documents
1	Fabrication Procedure / Sequence
2	Inspection and Test Procedure, Quality acceptance procedure, Job procedure & Procedures for Erection and Commissioning
3	Installation, Operation and maintenance Manual
4	Storage & Handling procedure, Protection and Preservation Procedures

2.3.4 Section D : Inspection and Test Records including IBR certificates & all reports.

2.3.5 Section E : Spare Parts and Tool List

2.3.6 Section F : As built drawings

In this section asbuilt drawings for all site fabricated items, engineering drawings like process, piping, civil, electrical, instrumentation, plot plan, fire fighting, line schedules, pipe supports index/register, piping isometrics, fire fighting etc. shall be compiled in an orderly manner.

1. The file format shall be labeled as mentioned in section 3
2. All as built drawings (Hard copy) shall be approved by authorised signatory/ Inspection agency with seal & sign
Items mentioned from 2.3.2 to 2.3.6 are indicative only, any deviation from this shall be approved by concern EIC of MRPL.

2.3.7 Section G : Digital Copy

1. Two sets of digital copies shall be submitted in CD/DVD with proper lable. If size of the total files of a PO/Equipment is crossing more than 10GB same to be submitted in external hard disk. Master index for all the files and file index for individual file must be available in searchable pdf/ Excel format.

SPC00009	1	1000183908	Page 4 of 8
Doc. No.	Rev	SAP/DMS/DIR	PAGE



**PROCUREMENT OF VALVES FOR CONFIDENTIAL DEMO PLANT AT
MRPL, MANGALURU, KARNATAKA**

	MANGALORE REFINERY AND PETROCHEMICALS LIMITED	
	PROCEDURE FOR FINAL DOCUMENTATION	SPC00009 Rev.1

2. All drawings shall be on the latest version of AutoCAD. If drawing is prepared in other format same need to be converted in to the latest AutoCAD version..
3. Engineering documents/drawings/design calculation/design specification prepared using any software shall be submitted in native format and same output is also to be provided in searchable pdf version.

Operating manuals and others documents shall be on MS Word / Excel or on searchable pdf. format. Soft copies should be segregated index wise as per clause no. 2.3.1 contents of the document folder. Total document folders must not be scanned in a single file.

4. Hand written/filled test reports to be submitted in pdf format.
5. Radiography films preferably to be submitted in digital format.

2.4 FIELD INSPECTION DOCUMENTATION

- 2.4.1 A detailed index to the content shall be available at the beginning of each file
- 2.4.2 Each inspection reports shall be indexed with the report number and number of pages
- 2.4.3 All Documents/Reports shall be approved in its totality by stamping & signing the Master Indexes as per section 2.2.1.
- 2.4.4 Radiography films shall be indexed and included with the final documentation package.
- 2.4.5 All radiographic films shall be put in an aluminum box/container with lock and key.
- 2.4.6 As built drawings if any shall be compiled as per section 2.3.6
- 2.4.7 Digital Copy : as per clause no. 2.3.7

3. FILE FORMAT OF DOCUMENTATION FOLDER

- 3.1 **Filing** : As far as possible separate folder has to be prepared for each equipment / system / service, however if documentation for a particular equipment / system /service are required to be filed in more than one files due to the volume, identical folder no. suffixing numbers of files e.g. 1/5, 5/5 etc shall be mentioned. On the other hand if the volume of documentation is less one folder may be used for more than one equipment of the same group, e.g. two or more pumps may be filed in one file, but not pumps, compressors, exchanger etc in one single file.

SPC00009	1	1000183908	Page 5 of 8
Doc. No.	Rev	SAP/DMS/DIR	PAGE



**PROCUREMENT OF VALVES FOR CONFIDENTIAL DEMO PLANT AT
MRPL, MANGALURU, KARNATAKA**

	MANGALORE REFINERY AND PETROCHEMICALS LIMITED	
	PROCEDURE FOR FINAL DOCUMENTATION	SPC00009 Rev.1

- 3.2 **Drawing Filing** : Each single drawing shall be put in separate transparent A/4 size drawing (non sticky) pouch and shall not be punched.
- 3.3 **File size** : All documents and drawings shall be compiled in A4 size file(s) (28cm x 31cm), with 2-clips. Width of the file can be, 6.0 cm or 7.5 cm or 9.0 cm. based on the volume of documents
- 3.4 **Document size** : The documents / drawings submitted in file shall be in its original size (A0/A1/A2/A3/A4), and to be folded in A4 size to accommodate in the A4 size drawing pouch as mentioned in 3.2.
- 3.5 **Digital Copies** : Each single CD/DVD shall have proper lables and to be filed in a separate distinct section of the document folder.
File label : Each file shall display following information on its spine.

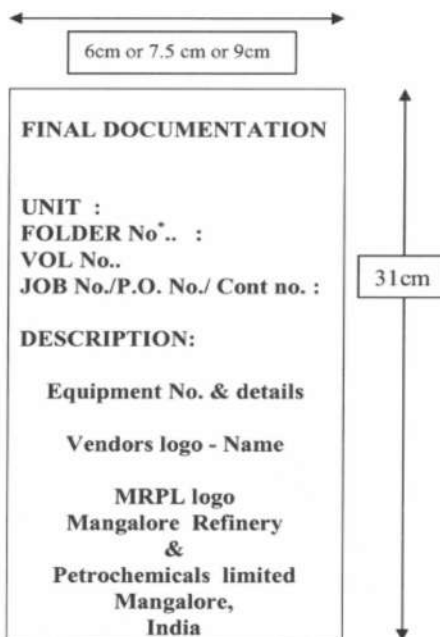

* To be provided in consultation with PMC / MRPL Engineering Documentation Centre.

SPC00009	1	1000183908	Page 6 of 8
Doc. No.	Rev	SAP/DMS/DIR	PAGE



**PROCUREMENT OF VALVES FOR CONFIDENTIAL DEMO PLANT AT
MRPL, MANGALURU, KARNATAKA**

	MANGALORE REFINERY AND PETROCHEMICALS LIMITED	
	PROCEDURE FOR FINAL DOCUMENTATION	SPC00009 Rev.1

4. SUBMISSION OF DOCUMENTS

4.1 All final documents duly compiled by this procedure alongwith deviation note as mentioned in section 1.3 shall be handed over to MRPL Engineering Documentation Centre through PMC / consultant / Engineer-in-charge of the project.

4.2 Completion Certificate from PMC/Consultant/Engineer-in charge, as per following format shall be attached in all document folder

COMPLETION CERTIFICATE OF FINAL DOCUMENTATION

Name of Supplier/ Contractor :
 Customer :
 Project :
 Project No. :
 Purchase Order No./ Contract No. :
 Purchase Requisition No./ Tender No. : Rev.No.:

Certified that the Engineering Documents / Manufacturing & Test Certificates submitted by the supplier are duly checked by us and found complete in all respect in accordance with the final documentation procedure No. SPC-000009 Rev 01.

Signature : Signature :
 Date : Date :
 Name : Name :
 Designation : Designation :
 Department : Department :

Supplier /Contractor

PMC/Overall contractor

4.3 Piecemeal submission shall be avoided.

SPC00009	1	1000183908	Page 7 of 8
Doc. No.	Rev	SAP/DMS/DIR	PAGE



**PROCUREMENT OF VALVES FOR CONFIDENTIAL DEMO PLANT AT
MRPL, MANGALURU, KARNATAKA**

	MANGALORE REFINERY AND PETROCHEMICALS LIMITED
PROCEDURE FOR FINAL DOCUMENTATION	SPC00009 Rev.1

- 4.4 If any document /drawing is required to be submitted in later date after submission of final folder, shall clearly appear in the content (section 2.3.1) with a note "LATER" duly approved by PMC / Consultant / Engineer-in charge
- 4.5 Work related Piping and Civil area drawings to be updated "Asbuilt" by PMC/Contractor with their respective changes at site.
- 4.6 Number of sets of Final Documents

Sr.No.	Document Group	# Copies	Digital File
1	Basic /Extended Design Packages	1	2
2	Vendor / Engineering Documentation / Drawings (As-Built Final)	1(original)	2
3	Final Field Inspection Reports, Documents & Drawings (Drawings As-Built certified)	1(original)	2
4	Radiography films	1	2

SPC00009	1	1000183908	Page 8 of 8
Doc. No.	Rev	SAP/DMS/DIR	PAGE



**PROCUREMENT OF VALVES FOR CONFIDENTIAL DEMO PLANT AT
MRPL, MANGALURU, KARNATAKA**

ANNEXURE – F TO SPC

Vulnerability Atlas of India

Vulnerability Atlas of India (VAI) is a comprehensive document which provides existing hazard scenario for the entire country and presents the digitized State/UT-wise hazard, maps with respect to earthquakes, winds and floods for district-wise identification of vulnerable areas. It also includes additional digitized maps for thunderstorms, cyclones and landslides. The main purpose of this Atlas is its use for disaster preparedness and mitigation at policy planning and project formulation stage.

This Atlas is one of its kind single point source for the various stakeholders including policy makers, administrators, municipal commissioners, urban managers, engineers, architects, planners, public etc. to ascertain proneness of any city/location/site to multi-hazard which includes earthquakes, winds, floods, thunderstorms, cyclones and landslides. While project formulation, approvals and implementation of various urban housing, buildings and infrastructures schemes, this Atlas provides necessary information for risk analysis and hazard assessment.

The Vulnerability Atlas of India has been prepared by Building Materials and Technology Promotion Council under Ministry of Housing and Urban Affairs, Government of India and available at their website www.bmtpc.org.

It is mandatory for the bidders to refer Vulnerability Atlas of India for multi-hazard risk assessment and include the relevant hazard proneness specific to project location while planning and designing the project in terms of:

- i) Seismic zone (II of V) for earthquakes
- ii) Wind velocity (Basic Wind Velocity:55, 50, 47, 44, 39 & 33 m/s)
- iii) Area liable to floods and Probable max. surge height
- iv) Thunderstorms history
- v) Number of cyclonic storms / severe cyclonic storms and max sustained wind specific to coastal region
- vi) Landslides incidences with Annual rainfall normal
- vii) District wise Probable Max. Precipitation.



**PROCUREMENT OF VALVES FOR CONFIDENTIAL DEMO PLANT AT
MRPL, MANGALURU, KARNATAKA**

SECTION- 5

GENERAL PURCHASE CONDITIONS (INDIGENOUS)

INDEX

1	DEFINITIONS	21	TRANSFER OF PROPERTY FROM THE VENDOR TO THE OWNER
2	REFERENCE FOR DOCUMENTATION	22	PRICE
3	CONFIRMATION OF ORDER	23	TERMS OF PAYMENT
4	SALES CONDITIONS	24	INVOICING AND NEGOTIATION OF DOCUMENTS
5	COMPLETE AGREEMENT	25	RECOVERY OF SUMS DUE
6	INSPECTION - CHECKING - TESTING	26	CHANGES
7	OFFICIAL INSTITUTIONAL TESTING	27	CANCELLATION
8	PROGRESS SCHEDULE & EXPEDITING	28	PATENTS AND ROYALTIES
9	WEIGHTS & MEASUREMENTS	29	PERFORMANCE GUARANTEE
10	DESPATCH INSTRUCTIONS	30	NON-WAIVER
11	OILS & LUBRICANTS	31	NON-ASSIGNMENT
12	SPARE PARTS	32	PART ORDER / REPEAT ORDER
13	PACKING AND MARKING	33	VENDOR'S DRAWINGS AND DATA REQUIREMENT
14	SHIPMENT AND SHIPMENT NOTICES	34	TECHNICAL INFORMATION
15	CONTROL REGULATIONS	35	SERVICES OF VENDOR'S PERSONNEL
16	TRANSIT RISK INSURANCE	36	VENDOR'S LIABILITIES
17	RESPECT FOR DELIVERY DATES	37	OWNER'S MATERIAL
18	DELAYED DELIVERY	38	HEADINGS
19	DELAYS DUE TO FORCE MAJEURE	39	ARBITRATION
20	REJECTION, REMOVAL OF REJECTED GOODS AND REPLACEMENT	40	JURISDICTION

1. DEFINITIONS:

The following expressions used in these General Purchase Conditions and the Purchase Order shall have the meaning indicated against each of them:



**PROCUREMENT OF VALVES FOR CONFIDENTIAL DEMO PLANT AT
MRPL, MANGALURU, KARNATAKA**

“OWNER/ CLIENT”: OWNER/ CLIENT means Mangalore Refinery and Petrochemicals Limited, a company incorporated in India having its registered office at Kuthethoor, P.O. Katipalla, Mangalore- 575 030, acting through CONSULTANT for the Project of Mangalore Refinery and Petrochemicals Ltd., at Mangalore and shall include its successors and assigns.

“GOODS/MATERIALS”: Goods and/or materials shall mean any of the articles, materials, Machinery, Equipment, Supplies, drawings, data and other property and all services including but not limited to design, delivery, installation, inspection, testing and commissioning specified to complete the order.

“VENDOR/ SELLER/ SUPPLIER”: Vendor/ SELLER/ Supplier shall mean the Person, firm or OWNER to whom this Purchase Order is issued.

“Contractual Delivery Date”: Contractual Delivery date is the date on or before which goods shall be delivered F.O.T despatching point/destination in accordance with the terms of the Purchase Order. The contractual delivery date/period is inclusive of all the lead time for engineering, procurement of raw materials, manufacturing, inspection, testing packing and any other activities whatsoever required to be accomplished for effecting the delivery at the agreed delivery point.

“Procurement co-ordinators/ Managers and Consultants”: Owner’s authorized representative appointed as procurement co-ordinators/ Manager and Consultants.

“INSPECTORS”: Inspectors deputed by Owner or procurement co-ordinator / managers and consultants.

PROJECT: Projects of Mangalore Refinery and Petrochemicals Limited at Kuthethoor, P.O. Katipalla, Mangalore- 575 030

“Purchase Order”: Purchase Order shall mean the Order placed on the Vendor for supply of material/services and shall include the general conditions, bidding conditions, specific conditions, material requisition/Purchase requisition, drawings, Price schedule and subsequent amendments mutually agreed upon. It may also be referred as order or contract.”

2. REFERENCE FOR DOCUMENTATION:

Purchase Order number must appear on order confirmation correspondence, drawings, invoices, shipping notes, packing and/ or any documents or paper connected with the Order.

3. CONFIRMATION OF ORDER:

The Vendor shall acknowledge the receipt of the Letter of Acceptance (LOA) / Fax of Acceptance (FOA) / Purchase Order within seven days following the date of the LOA / FOA / Purchase Order and shall there by confirm his acceptance of the FOA / Purchase Order without any exceptions. This acknowledgment will bear on FOA / Purchase Order and General Purchase Conditions

4. SALES CONDITIONS:

With Vendor’s acceptance of provisions of this Purchase Order, he waives and considers as cancelled any of his general sales conditions.



**PROCUREMENT OF VALVES FOR CONFIDENTIAL DEMO PLANT AT
MRPL, MANGALURU, KARNATAKA**

5. COMPLETE AGREEMENT:

The terms and conditions of this Purchase Order shall constitute the entire Agreement between the parties hereto. Changes will be binding only if the amendments are made in writing and signed by an authorised representative of the Owner.

6. INSPECTION-CHECKING-TESTING:

The equipment, materials and workmanship covered by the Purchase Order are subject to inspection and testing at any time prior to shipment and/or despatch and to final inspection within a reasonable time after arrival at the place of delivery. Inspectors shall have the right to carry out the inspection and testing which will include the raw materials at manufacturer's shop, at fabricator's shop and at the time of actual despatch before or after completion of packing.

All tests, mechanical and /or others and particularly those required by codes will be performed at Vendor's expenses and in accordance with Inspector's instructions. The Vendor will also bear the expenses concerning preparation and rendering of tests as may be required by Boiler Inspectorate or such other statutory testing agencies or by any other reputed Inspection agencies as may be nominated by the Owner for non-IBR items, inspecting authority shall be Owner/ CONSULTANT.

The salaries and fees of Inspectors and their travelling, lodging and boarding expenses will not be borne by the Vendor (unless inspection becomes infructuous due to any omission or commission on the part of the Vendor). Before shipping or despatch, the equipment and/or materials will have to be checked and stamped by Inspectors who are authorised also to forbid the use and despatch of any equipment and/or materials which during tests and inspection fail to comply with the specification, codes and testing requirements.

The Vendor shall:

- Inform Procurement Coordinator/Managers at least eight days in advance of the exact place, date and time of rendering the equipment or materials for required inspection.
- Provide free access to Inspectors during normal working hours to Vendor's or his/its sub-Vendor's works and place at their disposal all useful means of performing, checking, marking, testing, inspection and final stamping.

Even if the Inspections and tests are fully carried out, Vendor would not be absolved to any degree from his responsibilities to ensure that all equipments and materials supplied comply strictly with requirements as per agreement both during constructions, at the time of delivery, inspection, on arrival at site and after its erection or start-up and guarantee period as stipulated in Clause 29 herein.

The Vendor's responsibility will not be lessened to any degree due to any comments made by Procurement Coordinators/Managers and Inspectors on the Vendor's drawings or specifications or by inspectors witnessing any chemical or physical tests. In any case, the equipment must be in strict accordance with the Purchase Order and/or its attachments failing which the Owner shall have the right to reject the goods and hold the Vendor liable for non-performance of contract.



**PROCUREMENT OF VALVES FOR CONFIDENTIAL DEMO PLANT AT
MRPL, MANGALURU, KARNATAKA**

7. OFFICIAL INSTITUTIONAL TESTING:

In addition to testing and inspection by Inspectors mentioned above, Lloyds register Industrial services or similar institutional agencies like Boiler-Inspectorate may be assigned for official testing of all coded equipment. The Vendor shall ensure that all Procedures for preparation and Performance of test prescribed by such institution shall be completed scrupulously.

The Vendor is required to send to such institutions as may be designed by the Owner at least three sets of fabricated / manufactured drawings for each equipment and calculations. All manufacturer's mill test certificates and analytical reports from material laboratories in respect of all raw material and components employed shall have to be presented to such Institution's Inspectors in the number of copies required. Vendor shall be responsible for any delay in submission of necessary certificates. The Vendor shall maintain close liaison with Procurement Co-ordinators and Institution's Inspectors to maintain Schedule and delay, if any, in this process will not be taken into consideration as a cause of Force Majeure.

8. PROGRESS SCHEDULE & EXPEDITING

- 8.1 VENDOR within 2 weeks of award shall submit to OWNER, his Delivery schedule regarding the documentation, manufacture, testing, supply, erection and commissioning of the GOODS.
- 8.2 For items other than bulk, the Delivery schedule will be in the form of a network or a bar chart clearly indicating all main or key events regarding documentation, supply of raw materials, manufacturing, testing, delivery, erection and commissioning.
- 8.3 VENDOR shall update the template online on monthly basis to keep OWNER updated on the progress of the execution of Order and achievement of targets set out in time bar chart.
- 8.4 The Procurement Co-coordinator/ Managers shall have the right to inspect VENDOR's premises with a view to evaluating the actual progress of work on the basis of VENDOR's Delivery schedule.
- 8.5 The Procurement Co-coordinator/ Managers shall have free access to Seller's shop and/or sub-Supplier's shop at any time and they shall be provided all the necessary assistance and information to help them perform their job.
- 8.6 Irrespective of such inspection, in case of any delay, Owner cannot be held responsible. However, if delay is expected, at the earliest possible date, VENDOR shall advise Owner, of anticipated delay in the progress.
- 8.7 Notwithstanding the above, in case progress on the execution of order at various stages is not as per phased Delivery schedule and is not satisfactory in the opinion of the OWNER which shall be conclusive or VENDOR shall neglect to execute the order with due diligence and expedition or shall contravene the provisions of the order, OWNER shall be entitled to take action in accordance with the provisions of the Order.

9. WEIGHTS AND MEASUREMENTS:

All weights and measurements recorded by Procurement Coordinators/Managers on receipt of goods at the site will be treated as final.



**PROCUREMENT OF VALVES FOR CONFIDENTIAL DEMO PLANT AT
MRPL, MANGALURU, KARNATAKA**

Vendor's shipping documents and Invoices must contain the following data:

- I. Unit net weight
- II. Unit gross weight (packing included)
- III. Dimensions of packing

10. DESPATCH INSTRUCTIONS:

- 10.1 Unless Otherwise specifically advised in writing goods shall not be despatched without prior Inspection, testing and Release Order/Materials Acceptance Certificates issued by Inspectors.
- 10.2 Vendor shall exercise due care and ensure that the consignment shall be booked under appropriate railway classification, failing which any additional freight incurred by Owner due to Vendor's booking the material under a wrong classification shall be to Vendor's account.
- 10.3 The goods shall be consigned in the name of consignee viz.

GGM (Projects)
Project Department,
Mangalore Refinery and Petrochemicals Limited,,
Kuthethoor P.O, Via: Katipalla, Mangalore- 575030, Karnataka

By the most economical and expeditious mode of transport to the destination as applicable for respective mode of despatches as follows:

- (a) By Rail in wagon load consignment to :

Projects Department, Mangalore Refinery and Petrochemicals Limited, Mangalore, Karnataka

- (b) By road transport to :

Projects Department, Mangalore Refinery and Petrochemicals Limited, Mangalore, Karnataka

- 10.4 Owner/procurement coordinators/manager reserve the rights to advise any change in despatching point/destination and/or mode of transport as may be required. Any extra expenditure on this account supported by documentary evidence, will be reimbursed by the Owner.

11. OILS & LUBRICANTS:

The first filling of oils and lubricants, if any, required for every equipments shall be included in the price. The Vendor shall also recommend the quality / quantity of oils and lubricants required for one year continuous operation.

12. SPARE PARTS:

The Vendor must furnish itemwise and priced list of spare parts required for two years operation of the equipment and prime movers also.

The Vendor shall provide the necessary cross - sectional drawing to identify the spare parts numbers and their location as well as an inter changeability chart.



**PROCUREMENT OF VALVES FOR CONFIDENTIAL DEMO PLANT AT
MRPL, MANGALURU, KARNATAKA**

13. PACKING AND MARKING:

All fragile and exposed parts will be packed with care and the packages shall bear the words "WITH CARE" both in English and Hindi.

All nozzle, PIPING BULK 1(PIPES, FITTINGS, CS FLANGE, SS FLANGE)and all sheets shall be marked with strips bearing progressive numbers.

All nozzle holes and openings as also all delicate surfaces shall be carefully protected against bad weather. Flange faces of all nozzles shall be protected by blanks.

All threaded fittings shall be greased and provided with plastic caps.

All manufactured surfaces shall be painted with rust proof paint.

Equipment / materials shall be protected by suitable coat of paint and all bright parts protected from rust by application of anti rust coating as may be necessary. All machined surfaces shall be suitably protected.

All small pieces shall be packed in cases. All equipments / materials shall be suitably packed for rail, road or other appropriate transport. The packing shall be strong enough to ensure safe preservation up to the final point of destination.

The Vendor shall be held liable for all damages or breakage to the goods due to defective or insufficient packing as well as for corrosion due to insufficient protection.

On three sides of the packages the following marks shall appear clearly visible and in indelible paint at Vendor's care and expenses.

From : (Vendor)

To: Mangalore Refinery and Petrochemicals Limited.,
Projects Department,
Kuthethoor P.O., Via: Katipalla, Mangalore-575 030

Order No.:	Rev. No.:		
Item :		Net Weight:	Kgs.
Gross Weight		Kgs.	
Case No.	of Total cases:		
Dimensions			

For every order and every shipment, packages must be marked with serial progressive numbering. All packages that require special handling and transport should have their center of gravity and points at which they may be slung or gripped clearly indicated and marked "ATTENTION SPECIAL LOAD HANDLE WITH CARE" both in English and Hindi Language.

14. SHIPMENT AND SHIPMENT NOTICES:

The Vendor shall make shipment only after prior approval by inspectors whenever specifically mentioned. In the event of the Vendor having been advised to hold shipment(s) for any reason whatsoever the Vendor shall hold the materials in his/its ware house for at least 30 days without any compensation or without prejudice to any reduction in price already accrued on account of delays.



**PROCUREMENT OF VALVES FOR CONFIDENTIAL DEMO PLANT AT
MRPL, MANGALURU, KARNATAKA**

Immediately after shipment, Vendor shall inform despatch particulars to the Owner/procurement coordinators hereunder:

2 copies to the GM (Projects)
Mangalore Refinery and Petrochemicals Limited,
(Name of the Projects)
Kuthethoor P.O., Via: Katipalla, Mangalore- 575 030, Karnataka

15. CONTROL REGULATIONS :

The supply, despatch and delivery of goods shall be arranged by the Vendor in strict conformity with the statutory regulations including provision of Industries (Development and Regulation) Act, 1951 and any amendment thereof as applicable from time to time. The Owner disowns any responsibility for any irregularity or contravention of any of the statutory regulations in manufacture or supply of his stores covered by this order.

16. TRANSIT RISK INSURANCE:

Transit Risk Insurance shall be covered by the Owner against its Open General Policy. The Vendor shall advise the dispatch particulars to the Insurance Company as indicated in the Purchase order under advice to the Procurement Coordinators / Managers immediately after shipment.

17. RESPECT FOR DELIVERY DATES:

Time of delivery as mentioned in the Purchase Order shall be the essence of the agreement and no variation shall be permitted except with prior authorisation in writing from the Owner. Goods should be delivered securely packed and in good order and condition at the place and within the time specified in the Purchase Order for their delivery. Where no delivery period is expressly stated, it shall be construed as seven days from the date of placing the order. The Owner reserves the right to defer the period of delivery in writing.

18. DELAYED DELIVERY:

The time and date of delivery of stores/materials/ equipment as stipulated in the Order shall be deemed to be the essence of the contract. In case of delay in execution of the order beyond the date of delivery stipulated in the order or any extensions sanctioned, the Owner may at his option either:

- (i) Accept delayed delivery at prices reduced by a sum equivalent to half percent (1/2%) of the value of any goods not delivered for every week of delay or part thereof, limited to a maximum of 5% of the total order value.
- (ii) Cancel the order in part or full and purchase such cancelled quantities from elsewhere on account and at risk of the Vendor, without prejudice to its right under (i) above in respect to goods delivered.

19. DELAYS DUE TO FORCE MAJEURE:

- 19.1 In the event of causes of Force Majeure occurring within the agreed delivery terms, the delivery dates can be extended by the Purchaser on receipt of application from the VENDOR without imposition of price reduction. Only the following shall be considered as force majeure:



**PROCUREMENT OF VALVES FOR CONFIDENTIAL DEMO PLANT AT
MRPL, MANGALURU, KARNATAKA**

- a) Act of terrorism;
 - b) Riot, war, invasion, act of foreign enemies, hostilities (whether war be declared or not), civil war, rebellion, revolution, insurrection of military or usurped power;
 - c) Ionizing, radiation or contamination, radio activity from any nuclear fuel or from any nuclear waste from the combustion of nuclear fuel, radioactive toxic explosive or other hazardous properties of any explosive assembly or nuclear component;
 - d) Epidemics, earthquakes, flood, fire, hurricanes, typhoons or other physical natural disaster, but excluding weather conditions regardless of severity; and
 - e) Freight embargoes, strikes at national or state-wide level or industrial disputes at a national or state-wide level in any country where Works are performed, and which affect an essential portion of the Works but excluding any industrial dispute which is specific to the performance of the Purchase Order.
- 19.2 For the avoidance of doubt, inclement weather, third party breach, delay in supply of materials (other than due to a nationwide transporters' strike) or commercial hardship shall not constitute a Force Majeure event.
- 19.3 The VENDOR must advise the Purchaser by a registered letter duly certified by a statutory authorities, the beginning and the end of the delay immediately, but in no case later than 10 days of the beginning and end of each cause of Force Majeure condition as defined above.
- 19.4 The extension of time shall be the sole remedy of the VENDOR for any delay under this clause and the VENDOR shall not be entitled in addition to or in lieu of such extension to claim any damages or compensation on any account whatsoever whether under the law governing contracts or any other law in force, and the VENDOR hereby waives and disclaims any and all contrary rights.
- 19.5 In case force majeure conditions persists for period exceeding 02 (Two) Months, the Purchaser reserves the right to cancel the Purchase order or part of it.

20. REJECTION, REMOVAL OF REJECTED GOODS AND REPLACEMENT:

In case the testing and inspection at any stage by Inspectors reveal that the equipment, material and workmanship do not comply with the specification and requirements, the same shall be removed by the Vendor at his/its own expense and risk within the time allowed by the Owner. The Owner shall be at liberty to dispose of such rejected goods in such a manner as he may think appropriate. In the event the Vendor fails to remove the rejected goods within the period as aforesaid, all expenses incurred by the Owner for such disposal shall be to the account of the Vendor. The freight paid by the Owner, if any, on the inward journey of the rejected materials shall be reimbursed by the Vendor to the Owner before the rejected materials are removed by the Vendor.

The Vendor shall have to proceed with the replacement of that equipment or part of the equipment at MRPL stores / site, if so required by the Owner, without claiming any extra payment. The time taken for replacement in such event will not be added to the contractual delivery period. Any rejection, removal of rejected goods/material and replacement shall be applicable only up to guarantee period or extended guarantee period as applicable.



**PROCUREMENT OF VALVES FOR CONFIDENTIAL DEMO PLANT AT
MRPL, MANGALURU, KARNATAKA**

21. TRANSFER OF PROPERTY FROM THE VENDOR TO THE OWNER.

The transfer of property shall be deemed to have taken place as follows subject to the provisions herein contained:

- 21.1 F.O.T. dispatch point: On handing over the equipment to the carrier against receipt and such receipt having been passed over to the Owner.
- 21.2 F.O.T. Project site: On receipt of material at Project site.
- 21.3 Equipment sent freight/ carriage paid to the Refinery site: On receipt of goods at site.
- 21.4 Equipment erected by the Vendor; on acceptance at job site.
- 21.5 Equipment commissioned by the Vendor: On taking over by the Owner for regular operation after test run at maximum capacity for specified period satisfactorily performed.

22. PRICE:

Unless otherwise agreed to in the terms of the Purchase Order, the price shall be:

- a) Firm and not subject to escalation for any reasons whatsoever till the execution of entire order even though it might be necessary for the order execution to take longer than the delivery period specified in the order.
- b) Inclusive of adequate road/ rail worthy packing and forwarding charges upto effecting delivery at F.O.T. despatch point in all cases and railway freight whenever F.O.T/ F.O.R. destination delivery terms are agreed to but exclusive of transit insurance.
- c) Exclusive of Central/State Sales Tax, Excise Duty and or such imposts which are leviable by law on sales of finished goods to Owner and/or Octroi duty, if any, leviable at destination/ project site. The nature and extent of such levies shall be shown separately.

23 TERMS OF PAYMENT:

Payment against invoice shall normally be made within 30 days of receipt and acceptance of equipment/materials at site. However, Owner may consider payment of 90 percent against despatch documents balance 10 percent within 30 days of receipt and acceptance of equipment / materials at site, provided the value of Purchase Order exceed Rs. 50000/.

The Excise Duty, Service Tax, and Karnataka VAT shall not be included in the quoted prices and shall be payable at actuals. The amount of Excise Duty, Service Tax, and VAT shall only be payable against submission of Cenvatable/ Vatable invoices.

The Vendor shall as a precondition to any Payment exceeding 90% (Ninety percent) of the total contract value, furnish to the Owner in cash or in bank guarantee from a Scheduled/ Nationalised Bank in a form approved by the Owner for an amount of 10% of the contract value as security for the due performance of all the Vendor's liability in terms of and/or in connection with the contract. This security will be released after the expiry of the period of performance guarantee.

The financial settlement of Vendor's Invoice is liable to be withheld in the event the Vendor has not complied with submission of drawing, data and such documentation as called for in Purchase Order and/or as required otherwise.



**PROCUREMENT OF VALVES FOR CONFIDENTIAL DEMO PLANT AT
MRPL, MANGALURU, KARNATAKA**

24. INVOICING & NEGOTIATION OF DOCUMENTS

Invoices and other documents shall be sent as hereunder:

- i) - Original + 1 copy to GM (Finance),
Mangalore Refinery and Petrochemicals Limited,
(Name of the Project)
Kuthethoor P.O,
Via: Katipalla, Mangalore- 575 030, Karnataka
- ii) - 2 copies to GM (Projects),
Mangalore Refinery and Petrochemicals Limited,
(Name of the Project)
Kuthethoor P.O,
Via: Katipalla, Mangalore- 575 030, Karnataka, along with technical catalogues,
Inspection certificate

2 copies to (concerned Consultant)

In case the payment is against despatch documents through bank then:

Original invoice alongwith RR/GC note and Inspection certificate etc. should be sent to:

WILL BE INFORMED LATER

with a stipulation that the Bankers shall send prompt advice upon the receipt of documents to the

GM (Finance),
Mangalore Refinery and Petrochemicals Limited,
(Name of the Project),
Kuthethoor P.O., Via: Katipalla,
Mangalore- 575 030, Karnataka

- i) 1 copy shall be directly sent to GM (Finance) ,
Mangalore Refinery and Petrochemicals Limited,
(Name of the Project),
Kuthethur P.O, Katipalla, Mangalore- 575 030, Karnataka.
- ii) 2 copy to GM (Projects), Mangalore Refinery and Petrochemicals Limited,
(Name of the Project),
Kuthethur P.O, Katipalla, Mangalore- 575 030, Karnataka.
- iii) 2 copies to (concerned Consultant)

25. RECOVERY OF SUMS DUE:

Whenever any claim against the Vendor for payment of sum of money arises out of or under the contract, the Owner shall be entitled to recover such sums from any sum then due or which at any time thereafter may become due from the Vendor under this or any other contract with the Owner including right to en-cash the CPBG. In the event of encashment of CPBG the VENDOR shall restore the same to its original amount and should this sum be not sufficient to



**PROCUREMENT OF VALVES FOR CONFIDENTIAL DEMO PLANT AT
MRPL, MANGALURU, KARNATAKA**

cover the recoverable amount, the Vendor shall pay to the Owner on demand the balance remaining due.

26. CHANGES

The Owner has the option at any time to make changes in quantities ordered or in specifications and drawings. If such changes cause an increase or decrease in the price or in the time required for supply, an equitable, adjustment under this provision must be finalized within 10 days from the date when the change is ordered.

27. CANCELLATION:

27.1 CANCELLATION FOR DEFAULT

27.1.1 The Owner reserves the right to cancel the Purchase Order or any part thereof and shall be entitled to rescind the Purchase Order wholly or in part by a written notice of 10 days to the Vendor if:

- a) The Vendor fails to comply with the terms of the Purchase Order.
- b) The Vendor fails to adhere to delivery schedule of manufacturing and fails to deliver the goods on time and/or replace the rejected goods promptly.
- c) The Vendor becomes bankrupt or goes into liquidation.
- d) The Vendor makes a general assignment for the benefit of creditors.
- e) A receiver is appointed for any of the property owned by the Seller.

27.1.2 Upon receipt of the said cancellation notice, the Vendor shall discontinue all work on the Purchase Order and matters connected with it.

27.1.3 The Owner in that event will be entitled to procure the material in the open market and recover excess payment over the Vendor's agreed price, if any, from the Vendor reserving to itself the right to forfeit the /Contract Performance Bank Guarantee (CPBG), if any.

28. PATENTS AND ROYALTIES:

On acceptance of this order, the Vendor will be deemed to have entirely indemnified the Owner and Procurement Coordinators/Managers from any legal action or claims regarding compensation for breach of patent rights which the Vendor deems necessary to apply for manufacturing the ordered equipment and/or materials or which can in any way be connected in the manufacture.

29. PERFORMANCE GUARANTEE:

The Vendor shall guarantee that any and all materials used in execution of the Purchase Order shall be in strict compliance with characteristics, requirements and specifications agreed upon and that the same shall be free from any defects. Checking of the Vendor's drawings by Procurement Co-ordinators/Managers and their approval and permission to ship or despatch the equipment and materials guaranteed by Inspectors shall not relieve the Vendor from any part of his/its responsibilities of proper fulfillment of the requirement. The Vendor will guarantee that all materials and equipment shall be repaired or replaced as the case may be, at his own expense in case the same have been found to be defective in respect of materials,



**PROCUREMENT OF VALVES FOR CONFIDENTIAL DEMO PLANT AT
MRPL, MANGALURU, KARNATAKA**

workmanship or smooth and rated operation within a period of 12 months after the same have been put in service or 18 months from the date of shipment, whichever is earlier.

The guarantee period for the replaced parts shall be 12 months starting from the date on which the replacements are put in service. Acceptance by the Owner or Inspectors of any equipment and materials or their replacement will not relieve the Vendor of his/its responsibility concerning the above guarantee.

The Vendor shall furnish a Bank Guarantee (as per proforma attached as Appendix- 1 to GPC) to support Vendor's performance along with the payment documents for the first consignment. This bank guarantee shall remain in force for the entire period covered in Performance Guarantee plus three months. Any shortfall in the value of the BG as a result of encashment by the Owner either in full or in terms of Vendor's performance shall be made good by the Vendor within one week there of.

30. NON-WAIVER:

Failure of the Owner / Procurement Coordinators/ Managers to insist upon any of the terms or conditions incorporated in the Purchase Order or failure or delay to exercise any rights or remedies herein or by law or failure to properly notify Vendor in the event of breach, or the acceptance of or payment of any goods hereunder or approval of design shall not release the Vendor and shall not be deemed a waiver of any right of the Owner / Procurement Coordinators/Managers to insist upon the strict performance thereof or any of his or their rights or remedies as to any such goods regardless of when goods are shipped received or accepted nor shall any purported oral modification or revisions of the order by Owner/ Procurement Coordinators/Managers act as waiver of the terms hereof.

31. NON ASSIGNMENT:

The Purchase Order shall not be assigned to any other agency by the Vendor without obtaining prior written consent of the Owner.

32. PART ORDER/ REPEAT ORDER

Vendor hereby agrees to accept part order at Owner's option without any limitation whatsoever and also accept repeat order(s) within the period of Twelve months from the date of original purchase order on same unit prices, terms and conditions.

33. VENDOR'S DRAWING AND DATA REQUIREMENT:

The Vendor shall submit drawings, data and documentation in accordance with but not limited to what is specified in the requisition and/or in the Vendor drawings and data form attached to the Purchase Order and as called for in Clause 8, under the heading Expediting, above. Types, quantities and time limits of submitting this must be respected in its entirety failing which the Purchase Order shall not be deemed to have been executed for all purposes including settlement of payment since the said submission is an integral part of Purchase Order execution.



**PROCUREMENT OF VALVES FOR CONFIDENTIAL DEMO PLANT AT
MRPL, MANGALURU, KARNATAKA**

34. TECHNICAL INFORMATION:

Drawings, specifications and details shall be the property of the Owner and shall be returned by the Vendor on demand. The Vendor shall not make use of drawings and specifications for any purpose at any time save and except for the purpose of the Owner.

The Vendor shall not disclose the technical information furnished to or gained by the Vendor under or by virtue of or as a result of the implementation of the Purchase Order to any person, firm or body or Corporate authority and shall make all endeavors to ensure that the technical information is kept CONFIDENTIAL. The technical information imparted and supplied to the Vendor by the Owner shall at all times remain the absolute property of the Owner.

35. SERVICES OF VENDOR PERSONNEL:

Upon three week advance notice, the Vendor shall depute the necessary personnel to site for supervision of erection and start up of the equipment and train a few of the Owner's personnel for the operation and maintenance of the equipment, if required by the Owner. The terms and conditions for the services of the Vendor shall be mutually settled.

36. VENDOR'S LIABILITY

The Vendor's workmen or employees shall under no circumstances be deemed to be in Owner's employment and the Vendor shall hold himself responsible for any claims which they or their heirs, dependents or personal representatives may have or make for damages or compensation for anything done or committed to be done in the course of carrying out of the work covered by this Purchase Order, whether arising on Owner's premises or elsewhere and agrees to Indemnify the Owner against any such claim or claims if made against the Owner and all cost (as between attorney and client) of proceedings, suits or action which the Owner may incur or sustain in respect of the same. The Vendor shall also procure and keep in force at his own cost comprehensive automobile Liability insurance for adequate coverage in respect of all his vehicles visiting or plying in project premises. The Vendor shall also be responsible for compliance of existing laws in respect of their workmen and employees.

37. OWNER'S MATERIAL

- a) Owner's materials, if any, as per scope of work/ supply, shall be delivered to the Vendor after the Vendor submits the Bank Guarantee for Indemnifying the full value thereof strictly in the manner and as per proforma of Bank Guarantee approved by the Owner.
- b) Wherever possible, the material shall be consigned to Vendor's siding. In the event the Vendor does not have any siding or for any reasons, materials cannot be consigned to Vendor's siding, the same shall be consigned to the public siding/goods depot to be specifically confirmed by Vendor. Loading/Unloading and any handling from the siding/destination shall be arranged by the Vendor at his responsibility and cost.
- c) The Vendor shall give a firm and binding list of Owner's issue of materials and the desired schedule of its delivery to shop floor strictly in accordance with the sequence of fabrication vis-a vis the contractual delivery period.
- d) Unused materials or scrap from material supplied by the Owner to the Vendor shall be returned by the Vendor to the Owner or if the Owner so directs the Vendor may dispose of the same by sale or otherwise on such terms and conditions as the Owner may stipulate and the Vendor shall pay to the Owner the sale proceeds of the material so



**PROCUREMENT OF VALVES FOR CONFIDENTIAL DEMO PLANT AT
MRPL, MANGALURU, KARNATAKA**

disposed off by sale deducting there from expenses incurred by the Vendor on such sale, the quantum of such deduction to be mutually agreed upon in advance between the Owner and the Vendor.

38. HEADINGS:

The headings of the conditions hereof shall not affect construction thereof.

39. ARBITRATION:

ARBITRATION & CONCILIATION

39.1 ARBITRATION & CONCILIATION: Applicable for all the Tenders valuing above Rs.5 Lakhs:

Parties hereby agree as under:

If any difference or dispute (hereinafter referred as "Dispute") under the Contract arises, the party shall give a 60 days written notice ("Dispute Notice") to the identified officer of the other party mentioned in the Contract giving details of the Dispute. The Parties shall use all reasonable endeavours to resolve the Dispute mutually and amicably. All efforts by either party within these 60 days Dispute Notice Period shall be kept confidential by both the parties under Section 75 of the Arbitration and Conciliation Act, 1996. Parties shall not rely upon any views expressed or suggestions made by the other party, admissions made by the other party or the fact that the other party had indicated his willingness to enter into a settlement as evidence in any Forum / arbitration / court proceeding.

If Parties are unable to resolve the Dispute amicably within 60 days of receipt of the Dispute Notice, then after expiry of the 60 days' Dispute notice period, the aggrieved Party can refer the Dispute to conciliation and / or arbitration subject to terms and conditions contained herein below:

- 1) Parties further agree that following matters shall not be referred to Conciliation or Arbitration:
 - i) Any claim, difference or dispute relating to, connected with or arising out of MRPL decision to initiate any proceedings for suspension or banning, or decision to suspend or to ban business dealings with the Bidder / Contractor and/or with any other person involved or connected or dealing with bid / contract / bidder / contractor.
 - ii) Any claim, difference or dispute relating to, connected with or arising out of MRPL decision under the provisions of Integrity Pact executed between MRPL and the Bidder / Contractor.
- 2) Part-I: Conciliation (Not applicable in contracts valuing less than Rs. 10 lakhs)
- 3) Part-II: Arbitration (Not applicable in contracts valuing less than Rs. 5 lakhs) If the parties are not able to resolve the dispute through OEC or do not opt for conciliation through OEC, the party may invoke arbitration clause as provided in the contract.

39.2 PART - I: CONCILIATION: Resolution of disputes through conciliation by OEC (Not applicable in Contracts valuing less than Rs.10 lakhs):



**PROCUREMENT OF VALVES FOR CONFIDENTIAL DEMO PLANT AT
MRPL, MANGALURU, KARNATAKA**

If any dispute, difference, question or disagreement arises between the parties hereto or their respective representatives or assignees, in connection with construction, meaning, operation, effect, interpretation of the contract or breach thereof which parties are unable to settle mutually, the same may first be referred to conciliation through Outside Expert Committee ("OEC") to be constituted by MD, MRPL as provided hereunder:

Submission of proposal for OEC

Conciliation through OEC will be resorted in all cases involving disputed amount up to Rs 250 crores only. The disputed amount will be calculated by considering the amount of claim and counter-claim of the parties.

- i. Claimant shall give a 30 days' notice for conciliation. In cases where the contractor is claimant then the notice shall be given to the concerned MRPL office as per the contract, clearly bringing out the points of dispute and the amount claimed with documents in support of the claim and the party concerned shall not raise any new issue thereafter.

Constitution of OEC

- ii. MD, MRPL will have the sole discretion to constitute OEC. OEC will be formed from the panel of experts maintained by MRPL and will normally comprise of three members, one member from each category i.e., Technical, Finance, Commercial and Legal. However, there will be a single member OEC for disputes involving a claim and counter claim (if any) up to Rs 1 crore.
- iii. MD, MRPL will have authority to reconstitute an OEC to fill any vacancy or if any OEC member is not available to attend the OEC Meetings.
- iv. Upon constitution of the OEC, Head-Legal will issue the appointment letters to OEC members and inform same to the parties concerned.
- v. The OEC members shall give a declaration of independence and impartiality (in the format at **Annexure D**) to both the parties before the commencement of the OEC proceedings.

Proceedings before OEC

- vi. The claimant shall submit its statement of claims to OEC members, and to the party(s) prescribed in the appointment letter within 30 days of the issue of the appointment letter. The claims shall be raised as per the format at **Annexure E**.
- vii. The respondent shall file its reply and counter claim (if any) within 30 days of the receipt of the statement of claims. (As per aforesaid format at **Annexure E**).
- viii. Parties may file their rejoinder/additional documents, if any in support of their claim/counter claim within next 15 days. No documents shall be allowed thereafter.
- ix. OEC will commence its meetings only after completion of the pleadings.



**PROCUREMENT OF VALVES FOR CONFIDENTIAL DEMO PLANT AT
MRPL, MANGALURU, KARNATAKA**

- x. In case of 3 members OEC, 2 members will constitute a valid quorum and the meeting can take place to proceed in the matter after seeking consent from the member who is not available. If necessary video conferencing may be arranged. However, OEC Recommendations will be signed by all Members. Further, efforts must be made for unanimous recommendations.
- xi. The parties shall be represented by their in-house employees/executives. No party shall be allowed to bring any advocate or outside consultant/advisor/agent to contest on their behalf. Ex-officers of MRPL who have handled the dispute matter in any capacity are not allowed to attend and present the case before OEC on behalf of Contractor. However, ex-employees of parties may represent their respective organizations.
- xii. Solicitation or any attempt to bring influence of any kind on either OEC Members or MRPL is completely prohibited in conciliation proceedings and MRPL reserves the absolute right to close the conciliation proceedings at its sole discretion if it apprehends any kind of such attempt made by the Contractor or its representatives.
- xiii. Parties agree to rely only upon documentary evidence in support of their claims and not to bring any oral evidence in the OEC proceedings.
- xiv. OEC will give full opportunity of hearing to the parties before giving its recommendations.
- xv. OEC will conclude its proceedings in maximum 10 meetings, and give its recommendations within 90 days of its first meeting. OEC will give its recommendations to both the parties recommending possible terms of settlement MD, MRPL may extend the time/ number of meetings, in exceptional cases, if OEC requests for the same with sufficient reasons.
- xvi. OEC members will be paid fees (plus applicable tax) and provided facilities as detailed in clause xxix below, subject to revision by MRPL from time to time and subject to Government guidelines on austerity measures, if any. All the expenditure incurred in the OEC proceedings shall be shared by the parties in equal proportion. The parties shall maintain account of expenditure and present to the other for the purpose of sharing on conclusion of the OEC proceedings.
- xvii. Depending upon the location of the OEC members and the parties, the venue of the OEC meeting shall be either Delhi /Mangaluru / Bengaluru or any other location whichever is most economical from the point of view of travel and stay etc.
- xviii. Parties shall not claim any interest on claims/counterclaims from the date of notice invoking conciliation till execution of settlement agreement, if so arrived at. In case, parties are unable to reach a settlement, no interest shall be claimed by either party for the period from the date of notice invoking conciliation till the date of OEC recommendations and 30 days thereafter in any further proceeding.
- xix. Legally, parties are under no obligation to refer a dispute to conciliation or continue with conciliation proceedings. Parties are free to terminate the conciliation proceedings at any



**PROCUREMENT OF VALVES FOR CONFIDENTIAL DEMO PLANT AT
MRPL, MANGALURU, KARNATAKA**

stage as provided under the Arbitration and Conciliation Act, 1996 and subsequent amendments or re-enactment thereof.

Actions after OEC Recommendations

- xx. The recommendations of OEC are non-binding and the parties may decide to accept or not to accept the same. Parties are at liberty to accept the OEC recommendation with any modification they may deem fit.
- xxi. The contractor shall give its response to MRPL within 7 days of receiving OEC Recommendation.
- xxii. If the recommendations are acceptable to the contractor partly or fully, MRPL will consider and take a decision on OEC recommendations. MRPL shall communicate its decision to the contractor. If decision of MRPL is acceptable to the contractor, a settlement agreement under Section 73 of the Arbitration and Conciliation Act, 1996 will be signed within 15 days of contractor's acceptance and same shall be authenticated by all the OEC Members.
- xxiii. The timelines mentioned in the above guidelines are with an objective to achieve expeditious conclusion of OEC proceedings. However, it does not mean that any action beyond the timelines will be invalid. However, the party concerned will make all efforts to complete the actions within the stipulated time.
- xxiv. Parties shall keep confidential matters relating to the conciliation proceedings including minutes of OEC meeting and Recommendations of OEC. Parties shall not rely upon them as evidence in any Forum/arbitration/court proceeding, whether or not such proceedings relate to the dispute that is the subject of the conciliation proceedings,
 - a. Views expressed or suggestions made by the other party in respect of a possible settlement of the dispute.
 - b. Admissions made by the other party in the course of the OEC proceedings;
 - c. Proposals made by the OEC;
 - d. The fact that the other party had indicated his willingness to accept a proposal for settlement made by the OEC.
- xxv. Confidentiality extends also to the settlement agreement, except where its disclosure is necessary for purposes of implementation and enforcement. This stipulation will not apply to disclosure made by MRPL to Govt. of India, if required.
- xxvi. Subject to terms and conditions contained in the above paras, the provisions of the Part III of Arbitration and Conciliation Act, 1996 shall be acceptable to the conciliation proceedings and the parties and the OEC members shall be bound by the same.
- xxvii. If the parties are not able to resolve the dispute through OEC or do not opt for conciliation through OEC, the party may invoke arbitration clause as provided in the contract.
- xxviii. **Fees and Facility to the OEC Members :**
OEC members shall be entitled for the following fees plus applicable taxes per member and facilities:



**PROCUREMENT OF VALVES FOR CONFIDENTIAL DEMO PLANT AT
MRPL, MANGALURU, KARNATAKA**

Sl. No	Fees/Facility	Entitlement	To be paid by
1	Fees	Rs 20,000/- per meeting subject to maximum of Rs. 2,00,000/-* for the whole case. In addition, one OEC member chosen by OEC shall be paid an additional amount of Rs 10,000/- towards secretarial expenses in writing minutes/ OEC Recommendations.	Contractor
2.	Fee for attending meeting/s to authenticate the settlement agreement.	Rs 10,000/-	Contractor
3.	Transportation in the city of meeting	Car as per entitlement or Rs 2,000/- per day	Contractor
4.	Venue of the meeting	MRPL conference rooms/Hotels	MRPL
Facilities to be provided to the out-stationed member			
5.	Travel from the city of residence to the city of meeting	Business class air tickets/first class train tickets/ car/ reimbursement of actual fare. However, entitlement of air travel by Business class shall be subject to austerity measures, if any, ordered by Govt. of India.	Contractor
6.	Transport to and fro airport / railway station in the city of residence	Car as per entitlement or Rs 3,000/-	Contractor
7.	Stay for out stationed members	5 Star Hotel	MRPL
8.	Transport in the city of meeting	Car as per entitlement or Rs 2,000/- per day	Contractor

* except in exceptional cases, where the no. of meetings may extend beyond 10.

39.3 PART – II: ARBITRATION (Applicable in case of supply orders/Contracts with firms, other than Public Sector Enterprises) (Not applicable in contracts valuing less than ` 5 lakhs)

Except as otherwise provided elsewhere in the contract, if any dispute, difference, question or disagreement arises between the parties hereto or their respective representatives or assignees, in connection with construction, meaning, operation, effect, interpretation of the contract or breach thereof which parties are unable to settle mutually or through conciliation, the same shall be referred to Arbitration as provided hereunder:



**PROCUREMENT OF VALVES FOR CONFIDENTIAL DEMO PLANT AT
MRPL, MANGALURU, KARNATAKA**

- i) There shall be no arbitration for disputes involving claims up to ` 25 lakhs and more than ` 100 crores. The disputed amount will be calculated by considering the amount of claim and counter-claim of the parties. Unresolved disputes involving claims above ` 100 crores shall be adjudicated under the Commercial Courts, Commercial Division and Commercial Appellate Division of High Courts Act, 2015.
- ii) A party wishing to commence arbitration proceeding shall invoke Arbitration Clause by giving 60 days' notice to the other party. The notice invoking arbitration shall specify all the points of disputes with details of the amount claimed to be referred to arbitration at the time of invocation of arbitration and not thereafter. If the claim is in foreign currency, the claimant shall indicate its value in Indian Rupee for the purpose of constitution of the arbitral tribunal.
- iii) Arbitration can be invoked by giving Invocation Notice only after expiry of the 60 days' period as per Dispute Notice.
- iv) For a dispute involving claims above ` 25 lacs and upto ` 5 crores, in case other party is Claimant, MRPL will forward a list containing names of five jurists to the other party for selecting one from the list who will be appointed as sole arbitrator by MRPL. In case MRPL itself is the Claimant, it shall appoint the Sole Arbitrator by invoking the Arbitration clause and inform the Contractor. Such dispute shall be resolved on fast track procedure specified in Section 29B of the Arbitration and Conciliation Act, 1996.
- v) For a dispute involving claims above ` 5 crores and upto ` 100 crores, the claimant shall appoint an Arbitrator and communicate the same to the other Party in the Invocation Notice itself along with the copy of disclosure made by nominated Arbitrator in the form specified in Sixth Schedule of the Arbitration & Conciliation Act, 1996. For the purpose of Section 21, the Arbitration Proceeding shall commence only upon date of receipt of Invocation Notice complete in all respects mentioned above. The other Party shall then appoint the second Arbitrator within 15 days from the date of receipt of written notice. The two Arbitrators appointed by the Parties shall appoint the third Arbitrator, within 30 days, who shall be the Presiding Arbitrator. The parties agree that they shall appoint only those persons as arbitrators who accept the conditions of this arbitration clause. No person shall be appointed as arbitrator or presiding arbitrator who does not accept the conditions of this arbitration clause.
- vi) For the purpose of appointment of Arbitrator(s), claims amount shall be computed excluding claim for interest, if any.
- vii) The parties agree that they shall appoint only those persons as arbitrators who accept the conditions of this arbitration clause. No person shall be appointed as arbitrator or presiding arbitrator who does not accept the conditions of this arbitration clause.
- viii) Parties agree that there will be no objection if the Arbitrator appointed holds equity shares of MRPL and/or is a retired officer of MRPL / any PSU. However, neither party shall appoint its serving employee as arbitrator and shall have been retired before 3 years on the date of commencement of the Arbitration.



**PROCUREMENT OF VALVES FOR CONFIDENTIAL DEMO PLANT AT
MRPL, MANGALURU, KARNATAKA**

- ix) If any of the Arbitrators so appointed dies, resigns, becomes incapacitated or withdraws for any reason from the proceedings, it shall be lawful for the concerned party/arbitrators to appoint another person in his place in the same manner as aforesaid. Such person shall proceed with the reference from the stage where his predecessor had left if both parties consent for the same; otherwise, he shall proceed de novo.
- x) Parties agree that neither party shall be entitled for any pre-reference or pendente-lite interest on its claims, i.e. date of cause of action till date of Award by Arbitral Tribunal. Parties agree that claim for any such interest shall not be considered and shall be void. The Arbitrator / Tribunal shall have no right to award pre-reference or pendente-lite interest in the matter.
- xi) The arbitral tribunal shall make and publish the award within time stipulated as under:

Amount of Claims and Counter Claims (excluding interest)	Period for making and publishing of the award (counted from the date of first meeting of the arbitrators):
Upto Rs. 5 Crore	Within 8 months
Above Rs. 5 Crore	Within 12 months

The above time limit can be extended by the arbitrator, for reasons to be recorded in writing, with the consent of the parties.

- xii) The fees payable to each Arbitrator shall be as per rules framed by the High Court in whose territorial jurisdiction as per contract and seat of arbitration is situated. In case no rules have been framed, the fees prescribed may be as per Fourth Schedule of the Arbitration and Conciliation Act, 1996. However, Arbitrator may fix their fees keeping the aforesaid schedule as guiding factor.
- xiii) The parties may, after invocation of dispute, agree for sharing the cost of Arbitration equally on 50:50 basis.
- xiv) If after commencement of the Arbitration proceedings, the parties agree to settle the dispute mutually or refer the dispute to conciliation, the arbitrators shall put the proceedings in abeyance until such period as requested by the parties. Where the proceedings are put in abeyance or terminated on account of mutual settlement of dispute by the parties, the fees payable to the arbitrators shall be determined as under:
- (i) 20 % of the fees if the claimant has not submitted statement of claim.*
- (ii) 40 % of the fees if the pleadings are complete.*
- (iii) 60% of the fees if the hearing has commenced.*
- (iii) 80% of the fees if the hearing is concluded but the award is yet to be passed*
- xv) Each party shall pay its share of arbitrator's fees in stages as under:



**PROCUREMENT OF VALVES FOR CONFIDENTIAL DEMO PLANT AT
MRPL, MANGALURU, KARNATAKA**

- (i) 20% of the fees on filing of reply to the statement of claims.
- (ii) 40% of the fees on completion of pleadings.
- (iii) 20% of the fees on conclusion of the final hearing.
- (iv) 20% at the time when award is given to the parties.
- xvi) Each party shall be responsible to make arrangements for the travel and stay etc of the arbitrator appointed by it. Claimant shall also be responsible for making arrangements for travel / stay arrangements for the Presiding Arbitrator and the expenses incurred shall be shared equally by the parties. In case of sole arbitrator, MRPL shall make all necessary arrangements for his travel stay and the expenses incurred shall be shared equally by the parties.
- xvii) The Arbitration shall be held at the place from where the contract has been awarded. However, parties to the contract can agree for a different place for the convenience of all concerned.
- xviii) The Arbitrator(s) shall give reasoned and speaking award and it shall be final and binding on the parties.
- xix) Subject to aforesaid, provisions of the Arbitration and Conciliation Act, 1996 and any statutory modification or re-enactment thereof shall apply to the arbitration proceedings under this clause.
- xx) In so far as practicable, the Parties shall continue to implement the terms of the Contract notwithstanding the initiation of Arbitration proceedings.

39.4 Arbitration Clause applicable in case of Purchase Orders/ Contracts on Public Sector Enterprises

Ref: No.4 (1) /2011-DPE (PMA)-GL, Government of India, Department of Public Enterprises.
Dated 12th June 2013

In the event of any dispute or difference relating to, arising from or connected with the CONTRACT, such dispute or difference shall be referred by either party to the arbitration of one of the Arbitrators in the Department of Public Enterprises, to be nominated by the Secretary to the Government of India, In charge of the Bureau of Public Enterprises.

The Arbitration and Conciliation Act 1996 shall not be applicable to the Arbitration under this clause.

The award of the Arbitrator shall be binding upon the parties to the dispute, provided however; any party aggrieved by such award may make a further reference for setting aside or revision of the award to the Law Secretary, Deptt. of Legal Affairs, Ministry of Law and Justice, Government of India. Upon such reference, the dispute shall be decided by the Law Secretary or the Special Secretary / Additional Secretary, whose decision shall bind the parties finally and conclusively.



**PROCUREMENT OF VALVES FOR CONFIDENTIAL DEMO PLANT AT
MRPL, MANGALURU, KARNATAKA**

The parties in the dispute will share equally the cost of the arbitration as intimated by the Arbitrator.

39.5 JURISDICTION:

Contract / Purchase Order, including all matters connected with this Contract / Purchase Order shall be governed by the Indian law both substantive and procedural, for the time being in force and shall be subject to the exclusive jurisdiction of Indian Courts at Mangalore.

Foreign companies, operating in India or entering into Joint ventures in India, shall have to obey the law of the land and there shall be no compromise or excuse for the ignorance of the Indian legal system in any way.

Annexure D to Clause 39.2 - Conciliation

Declaration of independence and impartiality by OEC Member

To,

1. MRPL
2. Contractor.....

Subject: Declaration of independence and impartiality by OEC Member in the dispute between MRPLAnd.....under Contract No.....

I, the undersigned, hereby accept to act as Member of the Expert Committee and conciliate in the disputes under reference between the parties above named.

I confirm that I am aware of the requirements of law particularly of the Arbitration and Conciliation Act, 1996, to act as a conciliator. I am able to act as conciliator and I am available to act as Member of the Expert Committee.

I hereby declare that I am independent of each of the parties and have no ownership interest in any part of the contract under reference or any financial interest in the said contract. I have no interest in the outcome of the dispute or its settlement.

I hereby affirm that I shall act with honesty, integrity, diligence, and will remain independent and impartial while discharging my duties as conciliator/OEC Member. I will disclose any interest or relationship with the parties or the subject matter which might compromise in any manner my ability or capacity to remain impartial and independent in the matter.

The fees and other facilities offered to me and the terms and conditions contained in the appoint letter and guidelines issued by MRPL are acceptable to me. I will not demand for enhancement of the same.

(Signature)



**PROCUREMENT OF VALVES FOR CONFIDENTIAL DEMO PLANT AT
MRPL, MANGALURU, KARNATAKA**

Name:

Address:

Phone:

Email:

Date:

Annexure E to Clause 39.2 - Conciliation

STATEMENT OF CLAIM(S)/COUNTERCLAIM(S)

1. Chronology of the dispute
2. Brief of the contract
3. Brief history of the dispute:
4. Issues:
5. Details of claim(s)/Counter Claim(s):

SI NO	Description of claim(s)/Counter Claim	Amount (in INR/USD)	Relavnt Contarct Clause

1. Basis/Ground of claim(s)/counter claim(s) (along with relevant clause of contract)

Statement of claims may kindly be restricted to maximum limit of 20 pages. Relevant documents may be compiled and submitted along with the statement of claims. The statement of claims is to be submitted to all OEC members, to other party and to the office of Head Legal Services-MRPL, by post as well as mail.

Authorized Signatory of the Claimant

Place:

Contact No. :



**PROCUREMENT OF VALVES FOR CONFIDENTIAL DEMO PLANT AT
MRPL, MANGALURU, KARNATAKA**

Date:

Email:

40. JURISDICTION

The Vendor hereby agrees that the Court situated at Mangalore alone shall have the jurisdiction to hear and determine all action and proceedings arising out of this contract.

APPENDIX-1 TO GPC

**PROFORMA OF BANK GUARANTEE
(PERFORMANCE)**

(On non-judicial stamp paper of appropriate value)

To

Mangalore Refinery and Petrochemicals Limited,
(Name of the Project)
Kuthethoor P.O., Via: Katipalla, Mangalore- 575 030,
Karnataka, India

Dear Sirs,

In consideration of the Mangalore Refinery and Petrochemicals Limited, (Name of the Project) Kuthethoor P.O., Via: Katipalla, Mangalore- 575 030, Karnataka (India) (hereinafter called — “ The OWNER” which expression shall include its successors and assigns having awarded _____ work to

M/s(Name) _____ (Constitution) _____ (Address) _____

_____ (hereinafter referred to as “the Supplier” which expression shall wherever the subject or context so permits include its successors and assigns) a supply contract in terms inter alia, of the OWNER(s) letter No..... dated and the General Purchase Conditions of the OWNER and upon the condition of Supplier’s furnishing security for the Performance of the Supplier’s obligations and/or discharge of the Supplier’s liability under and/or in connection with the said supply contract upto a sum of Rs..... only amounting to 3% (three percent) of the total contract value.

We _____ (name) a body corporate registered/ constituted under the laws of _____ (hereinafter called “the Bank” which expression shall include its successors and assigns) with the intent to bind the Bank and its successors and assigns, hereby undertake to pay the OWNER at _____ (place) on first demand in writing without protest or demur or proof or condition any and all amounts from time to time demanded by the OWNER from the Bank with reference to this Guarantee/Undertaking upto an aggregate limit of Rs _____ (Rupees _____ only) AND the Bank doth hereby further agree as follows:

1. This Guarantee/Undertaking shall be a continuing Guarantee/ Undertaking and shall remain valid and irrevocable for all claims of the OWNER and liabilities of the Supplier arising upto and until midnight of..... provided that the Bank shall upon the written request of the OWNER made within 6 (six) months of the said date extend this Guarantee/Undertaking by a further 6 (six) months from the said date, within which the OWNER may make a demand hereunder.



**PROCUREMENT OF VALVES FOR CONFIDENTIAL DEMO PLANT AT
MRPL, MANGALURU, KARNATAKA**

2. This Guarantee/Undertaking shall be in addition to any other guarantee or security whatsoever that the OWNER may now or at any time anyway have in relation to the Supplier's obligations liabilities under and/or in connection with the said supply contract and the OWNER shall have full authority to take recourse to or reinforce this security in preference to the other security(ies) at its sole discretion, and no failure on the part of the OWNER in enforcing or requiring enforcement of any other security shall have the effect of releasing the Bank from its full liability hereunder.
3. The OWNER shall be at liberty without reference to the Bank and without affecting the full liability of the Bank hereunder to take an other security in respect of the Supplier's obligation and/or liabilities under or in connection with the said supply contract and to vary the terms vis-a-vis the Supplier of the said supply contract or to grant time and/or indulgence to the Supplier or to reduce or to increase or otherwise vary the prices of the total contract value or to release or to forebear from enforcement of all or any of the obligations of the Supplier under the said supply contract and/or the remedies of the OWNER under any other Security(ies) now or hereafter held by the OWNER and no such dealing(s), variation(s), reduction(s) or other indulgence(s) or arrangement(s) with the Supplier or release or forbearance whatsoever shall have the effect of releasing the Bank from its full liability to the OWNER hereunder or prejudicing rights of the OWNER against the Bank.
4. This Guarantee/Undertaking shall not be determined or affected by the liquidation or winding up, dissolution, or change of constitution or insolvency of the Supplier.
5. Bank hereby waives all rights at any time inconsistent with the terms of this Guarantee/Undertaking and the obligations of the Bank in terms hereof shall not be anyway affected or suspended by reasons of any dispute or disputes having been raised by the Supplier (whether or not pending before any Arbitrator, Officer, Tribunal or Court) or any denial of liability by the Supplier or any other order or Communication whatsoever by the Supplier stopping or preventing or purporting to stop or prevent any payment by the Bank to the OWNER in terms hereof.
6. Notwithstanding anything contained herein:
 - (a) The Bank's liability under this Guarantee/Undertaking shall not exceed Rs.
(Rupees only),
 - (b) This Guarantee/Undertaking shall remain in force upto and any extension(s) thereof; and
 - (c) The Bank shall be released and discharged from all liability under this Guarantee/Undertaking unless a written claim or demand is issued to the Bank on or before or the date of expiry of any extension(s) thereof if this Guarantee/Undertaking has been extended.
7. The Bank doth hereby declares that Shri _____(name & designation of the person authorised to sign on behalf of the Bank) is authorised to sign this Guarantee/Undertaking on behalf of the Bank and to bind the Bank thereby.

Yours faithfully,



**PROCUREMENT OF VALVES FOR CONFIDENTIAL DEMO PLANT AT
MRPL, MANGALURU, KARNATAKA**

(Signature)

NAME & DESIGNATION
NAME OF THE BANK

NOTE

1. This Guarantee/Undertaking is not to be witnessed.
2. This Guarantee is required to be stamped as an agreement according to the stamp duty act.
3. This Guarantee is required to be sent by Vendor's Bankers directly to the Owner.

APPENDIX-2 TO GPC

PROFORMA OF BANK GUARANTEE
(ADVANCE)

(On non-judicial paper of appropriate value)

B.G. No.

DATED:

TO

Mangalore Refinery and Petrochemicals Limited,
(Name of the Project)
Kuthethoor P.O., Via: Katipalla, Mangalore- 575 030,
Karnataka, India

THIS GUARANTEE executed at(Place of execution) this ____ day of 2009 by _____(Bank), _____(Address), and having its Head Office at.....(hereinafter referred to as "BANK") which expression shall, unless repugnant to the context or contrary to the meaning thereof, include its successors and assigns for the benefit of and in favour of Mangalore Refinery And Petrochemicals Limited, a Company incorporated in India and having its Registered Office at Kuthethoor P.O., Via Katipalla, Moodapadav, Mangalore-575 030, Karnataka, India (hereinafter referred to as " the Purchaser"), which expression shall, unless repugnant to the context or contrary to the meaning thereof, include its successors and assigns

WHEREAS the Purchaser has placed a Purchase Order No. _____ dated _____(hereinafter called "the Purchase Order") for a total value of _____(_____ Only) for supply of _____(Material),with _____(Seller), having its Registered/Corporate Office at _____(hereinafter referred to as "the Seller) which expression shall, unless repugnant to the context or contrary to the meaning thereof, includes its successors and assigns.



**PROCUREMENT OF VALVES FOR CONFIDENTIAL DEMO PLANT AT
MRPL, MANGALURU, KARNATAKA**

AND WHEREAS one of the conditions of the Purchase Order placed with the Seller is that the Purchaser should make an advance payment of _____ (_____ Only) being _____ % (_____ percent) of the Purchase Order value against an indemnity in the form of a BANK Guarantee from a BANK and in a form acceptable to the Purchaser.

AND WHEREAS the Seller has requested Bank to issue such guarantee for _____ (_____ Only) for a period upto.....(Date of expiry) in favour of the Purchaser.

NOW THIS GUARANTEE that in consideration of the Purchase having at the request of the Seller, agreed to accept a Guarantee from BANK in respect of _____ (_____ Only) required by the Seller from the Purchaser towards -----(---- percent) of the Purchase Order value as advance payment against supply of _____ (Material) as per the terms and conditions of the Purchase Order. BANK hereby undertake to make payment to the Purchaser without protest or demur and without recourse to the Seller and/or other Authorities upto and not exceeding altogether a sum of _____ (_____ Only) being the amount of _____ % (_____ Percent) of the Purchase Order value.

The decision of the Purchaser as to whether the terms and conditions of the Purchase Order have been observed or not shall be final and binding on the BANK.

The Purchaser may, without affecting BANK's liabilities and obligations hereunder, grant time or enter into other indulgence or compound with the Seller or enter into any agreement or agree to forbear or to enforce any of the terms and conditions of the Purchase Order against the Seller or agree to vary any of the terms and conditions of the Purchase Order.

This Guarantee shall not be affected by any change in the constitution of the Purchaser or the Bank or the Seller and shall remain in full force and effect until the liabilities of the Bank are discharged by the Purchaser.

For the purpose of giving effect to this guarantee, the Purchaser is entitled to act as if BANK were the Principal Debtor and BANK hereby waives all and any of its rights to surety-ship.

This Guarantee shall continue to be in force notwithstanding the discharge of the Seller by operation of law and shall cease only on payment of the full amount hereby secured by BANK to the Purchaser and also the claim of the Purchaser against the Seller in respect of the Purchase Order is fully satisfied.

The validity of the guarantee shall be extended upon request from the Seller from time to time.

This Guarantee issued by BANK shall be in addition to and not in substitution of any other guarantee or Security given or to be given by the Seller to the Purchaser in respect of the Purchase Order.



**PROCUREMENT OF VALVES FOR CONFIDENTIAL DEMO PLANT AT
MRPL, MANGALURU, KARNATAKA**

Demand or claim hereunder shall be deemed effective when served by hand or sent by Registered post to BANK, addressed as aforesaid.

The BANK's liability under this Guarantee is restricted to _____ (_____ Only).

Unless previously cancelled by the Purchaser, this guarantee shall remain in force upto _____ (Date of expiry) and shall stand cancelled on the expiry of the said period unless extended at the instance of the Seller.

Unless a demand or claim under this guarantee is made on BANK in writing within three months from the date of expiry of this guarantee, all the rights of the Purchaser against BANK shall be forfeited and BANK shall be relieved and discharged from all its liabilities hereunder.

These presents shall be governed by and construed in accordance with the Indian Law.

BANK hereby declares that it has the power to issue this Guarantee and the undersigned is / are fully authorised to sign and execute the same vide Power of Attorney datedissued to me/us by the Bank.

Notwithstanding anything contained hereinabove -

- a) Our liability under this guarantee is restricted to _____ (_____ Only)
- b) This guarantee shall be valid upto _____ (Date of expiry) and
- c) We are liable to pay the guaranteed amount or any part thereof under this guarantee only and only if you file / serve upon us a written claim or demand on or before _____ (3 months from the date of expiry)

SIGNED AND DELIVERED /(Persons duly authorised by banks)

PLACE:

DATE:

WITNESS

1. (Signature)

..... (Name and Address)

2. (Signature)

..... (Name and Address)



**PROCUREMENT OF VALVES FOR CONFIDENTIAL DEMO PLANT AT
MRPL, MANGALURU, KARNATAKA**

NOTE

1. This Guarantee is required to be stamped as an agreement according to the stamp duty act.
2. Bank shall provide details viz Contact Person, Phone No., Fax No., E-mail-ID, Address of regional/ controlling office of issuing bank for verifications of authenticity of bank guarantee.
3. The Advance Bank Guarantee shall be strictly as per above proforma and shall be through branches of Indian Public Sector Banks operating in vendor's country or the same shall be counter guaranteed by a branch of any Indian Bank in vendor's country.
4. Bank Guarantee from Indian branches of foreign (vendor's) banks will be accepted only if the Indian branch of the Bank is recognised as Scheduled Bank by Reserve Bank of India. However, Bank Guarantee from foreign branch will be accepted only if the same is countersigned by their Indian branch or by any Scheduled Indian Bank.
5. This Bank Guarantee shall be sent by the bank directly to:

GM(Projects)

Mangalore Refinery and Petrochemicals Limited,

(Name of the Project)

Kuthethoor P.O., Via: Katipalla, Mangalore- 575 030,

Karnataka, India



PROCUREMENT OF VALVES FOR CONFIDENTIAL DEMO PLANT AT
MRPL, MANGALURU, KARNATAKA

TENDER No: 3200000897

**FOR PROCUREMENT OF VALVES FOR CONFIDENTIAL DEMO
PLANT AT MRPL, MANGALURU, KARNATAKA.**

SECTION- 6

PRICE SCHEDULE



**PROCUREMENT OF VALVES FOR CONFIDENTIAL DEMO PLANT AT
MRPL, MANGALURU, KARNATAKA**

PREAMBLE TO PRICE SCHEDULE

1	Scope of supply including testing, inspection, documentation etc., shall be strictly as per Technical Specifications and other documents which are part of Tender.
2	Bidder shall furnish prices/details as above, in accordance with Technical Specifications
3	No stipulation, deviation, terms & conditions, presumption, basis etc. shall be stipulated in Price Part of the bid. Any condition if stipulated shall be treated as null and void and shall render the bid liable for rejection.
4	Bidder quoted prices shall be inclusive of Third Party Inspection Agency Charges. List of TPIA is provided in the SPC. TPI shall be arranged by Bidder.
5	Quoted Price shall be inclusive of all taxes/duties, P&F, Loading and Un-loading etc but exclusive of GST.
6	I) Adherence to scope of supply, Bidder can quote for both group-1 and group-2 or Only group-1/ group-2. Whichever material group bidder is quoting for, shall quote for all items in that group. II) Bidder shall agree to supply of material as per delivery schedule. III) Techno-commercially acceptable bid shall be evaluated on overall L1 basis separately for group-1 and Group-2.
7.	Bidder to Quote all the Line items of the Group. Otherwise if not Quoted any of the line item of the Group then it falls under rejection of the Group.
8.	For Check Valve & Gate Valve Group 1 For Butterfly Valve Group 2



PROCUREMENT OF VALVES FOR CONFIDENTIAL DEMO PLANT AT MRPL, MANGALURU, KARNATAKA

GROUP-1

Tender No:	3200000897
Tender Description :	PROCUREMENT OF VALVES FOR CONFIDENTIAL DEMO PLANT AT MRPL, MANGALURU, KARNATAKA

Name of Bidder : [Redacted]

						SUPPLY PRICE IN INR WITHOUT GST BUT INCLUDING P&F, LOADING, UN-LOADING, TPI, ALL TAXES & DUTIES ON FOT DESPATCH POINT BASIS	FREIGHT CHARGES UPTO MRPL MANGALORE SITE (IN INR)
--	--	--	--	--	--	--	--

Group 1 (FITTINGS)

Sl. No.	SIZE INCH	Description	MATERIAL	Qt y.	UOM	HSN Code	GST %	Unit rate in INR (Excludin g GST)	Price in INR (Excludin g GST)	Price in INR with GST	GST %	Freight rate in INR (Excludin g GST)	Total Freight in INR (Excludin g GST)	Total Freight in INR with GST
1	2	CHECK VALVE, FLANGED, CL 300 LB, RF/125 AARH, BS 1868, ASME B16.5	Body A 216 GR.WCB, Trim- 13% CR Steel	5	Nos.	To be Quoted in EPS	To be Quoted in EPS	To be Quoted in EPS	0.00	0.00	To be Quoted in EPS	To be Quoted in EPS	0.00	0.00
2	2	CHECK VALVE, FLANGED, CL 150 LB, RF/125 AARH, BS 1868, ASME B16.5	Body A216 GR.WCB, Trim 13% Crome Steel	8	Nos.	To be Quoted in EPS	To be Quoted in EPS	To be Quoted in EPS	0.00	0.00	To be Quoted in EPS	To be Quoted in EPS	0.00	0.00
3	2	GATE VALVE, FLANGED, CL 150 LB, RF/125 AARH, API 600/ISO 10434, ASME	Body A 216 GR.WCB, Trim- 13%Crome Steel	22	Nos.	To be Quoted in EPS	To be Quoted in EPS	To be Quoted	0.00	0.00	To be Quoted	To be Quoted	0.00	0.00



PROCUREMENT OF VALVES FOR CONFIDENTIAL DEMO PLANT AT MRPL, MANGALURU, KARNATAKA

		B16.5						in EPS			in EPS	in EPS		
4	2	GATE VALVE, FLANGED, CL 300 LB, RF/125 AARH, API 600/ISO 10434, ASME B16.5	Body A 216 GR.WCB, Trim-13% CR Steel	9	Nos.	To be Quoted in EPS	To be Quoted in EPS	To be Quoted in EPS	0.00	0.00	To be Quoted in EPS	To be Quoted in EPS	0.00	0.00
5	0.75	GATE VALVE, SCRF, CL 800, API 602/ISO 15761, ASME B 16.11	Body-A 105, 13% crome Steel	2	Nos.	To be Quoted in EPS	To be Quoted in EPS	To be Quoted in EPS	0.00	0.00	To be Quoted in EPS	To be Quoted in EPS	0.00	0.00
6	0.75	GATE VALVE, SW, CL 800, API 602/ISO 15761, ASME B 16.11	Body-A 105, Trim-Stellited, Stem-13%Crome	21	Nos.	To be Quoted in EPS	To be Quoted in EPS	To be Quoted in EPS	0.00	0.00	To be Quoted in EPS	To be Quoted in EPS	0.00	0.00
		Group-1 (Check Valve & Gate Valve) Total Amount								0.00	0.00		0.00	0.00
		LANDED COST IN INR AT MRPL SITE (Group-1)								0.00				
Note s:	1) P&F – The above price are inclusive of Packing & Forwarding, Loading etc.													
	2) In case the Actual Freight charges are higher than the freight charges quoted in the price bid, the difference in Freight charges shall be debited from the Vendors account at the time of bill Payment along with corresponding taxes applicable. In the case the actual freight charges are lower than the quoted price then owner will pay the actual freight charges.													
	3)													



PROCUREMENT OF VALVES FOR CONFIDENTIAL DEMO PLANT AT MRPL, MANGALURU, KARNATAKA

- | | |
|--|--|
| | <p>I) Adherence to scope of supply, Bidder can quote for both group-1 and group-2 or Only group-1/ group-2. Whichever material group bidder is quoting for, shall quote for all items in that group.</p> <p>II) Bidder shall agree to supply of material as per delivery schedule.</p> <p>III) Techno-commercially acceptable bid shall be evaluated on overall L1 basis separately for group-1 and Group-2.</p> |
|--|--|



PROCUREMENT OF VALVES FOR CONFIDENTIAL DEMO PLANT AT MRPL, MANGALURU, KARNATAKA

GROUP-2

Tender No:		3200000897											
Tender Description :		PROCUREMENT OF VALVES FOR CONFIDENTIAL DEMO PLANT AT MRPL, MANGALURU, KARNATAKA											
Name of Bidder :													

						SUPPLY PRICE IN INR WITHOUT GST BUT INCLUDING P&F, LOADING, UN-LOADING, TPI, ALL TAXES & DUTIES ON FOT DESPATCH POINT BASIS					FREIGHT CHARGES UPTO MRPL MANGALORE SITE (IN INR)			
Group 2 (Butterfly Valves)														
Sl. No.	SIZE INCH	Description	MATERIAL	Qty.	UOM	HSN Code	GST %	Unit rate in INR (Excluding GST)	Price in INR (Excluding GST)	Price in INR with GST	GST %	Freight rate in INR (Excluding GST)	Total Freight in INR (Excluding GST)	Total Freight in INR with GST
1	4	BUTTERFLY VALVE, FLANGED, CL 150 , WAF/125 AAR, BS EN 593, ASME B16.5	Body A 216 GR.WCB, Trim 13% Chrome Steel	2	Nos.	To be Quoted in EPS	To be Quoted in EPS	To be Quoted in EPS	0.00	0.00	To be Quoted in EPS	To be Quoted in EPS	0.00	0.00
Group-2 (Butterfly Valve) Total Amount										0.00	0.00		0.00	0.00
LANDED COST IN INR AT MRPL SITE (Group-2)						0.00								



PROCUREMENT OF VALVES FOR CONFIDENTIAL DEMO PLANT AT MRPL, MANGALURU, KARNATAKA

Notes:	1) P&F – The above price are inclusive of Packing & Forwarding, Loading etc.
	2) In case the Actual Freight charges are higher than the freight charges quoted in the price bid, the difference in Freight charges shall be debited from the Vendors account at the time of bill Payment along with corresponding taxes applicable. In the case the actual freight charges are lower than the quoted price then owner will pay the actual freight charges.
	3) I) Adherence to scope of supply, Bidder can quote for both group-1 and group-2 or Only group-1/ group-2. Whichever material group bidder is quoting for, shall quote for all items in that group. II) Bidder shall agree to supply of material as per delivery schedule. III) Techno-commercially acceptable bid shall be evaluated on overall L1 basis separately for group-1 and Group-2.



TENDER No.: 3200000897

**PROCUREMENT OF VALVES FOR CONFIDENTIAL DEMO
PLANT AT MRPL, MANGALURU, KARNATAKA**

CONTENTS

VOLUME II OF II

TECHNICAL SECTION

S. NO.	DESCRIPTION	Page No.
1	Technical Notes for Valves	181-200
2	QAP	201-207



**PROCUREMENT OF VALVES FOR CONFIDENTIAL DEMO PLANT AT MRPL,
MANGALURU, KARNATAKA**







**TECHNICAL NOTES
FOR VALVES**

STANDARD SPECIFICATION No.
6-44-0052 Rev. 7
Page 1 of 12

वाल्वों के लिए तकनीकी टिप्पणियाँ

TECHNICAL NOTES FOR VALVES

7	13.07.17	REVISED AND ISSUED AS STANDARD SPECIFICATION	 PK	 SH	 MI	 RN
6	04.08.10	REVISED AND ISSUED AS STANDARD SPECIFICATION	RN	ATD	SC	DM ND
5	04.07.08	REVISED AND ISSUED AS STANDARD SPECIFICATION	RN	SC	DM	VC
4	15.11.00	REVISED AND ISSUED AS STANDARD SPECIFICATION	RN	BRB	NS	MI
3	04.04.94	ISSUED IN LINE WITH GENERAL REVISION	AKG	NS	GRR	AS
Rev. No	Date	Purpose	Prepared by	Checked by	Standards Committee Convenor	Standards Bureau Chairman
Approved by						

Format No. 8-00-0001-F1 Rev. 0

Copyright EIL – All rights reserved

PROCUREMENT OF VALVES FOR CONFIDENTIAL DEMO PLANT AT MRPL,
MANGALURU, KARNATAKA

Abbreviations:

AARH	: Arithmetic Average Roughness Height
ANSI	: American National Standards Institute
API	: American Petroleum Institute
ASME	: American Society of Mechanical Engineers
ASTM	: American Society for Testing & Materials
BGO	: Bevel Gear Operator
BHN	: Brinell Hardness Number
BIS	: Bureau of Indian Standards
BS	: British Standard
BVIS	: Bureau Veritas Industrial Services
BW	: Butt Weld
CAT	: Category
CEIL	: Certification Engineers International Limited
CS	: Carbon Steel
DFT	: Dry Film Thickness
DNV	: Det Norske Veritas
DP	: Dye-Penetrant
eDMS	: Electronic Document Management System
IBR	: Indian Boiler Regulations
IGC	: Inter Granular Corrosion
IS	: Indian Standard
LT	: Low Temperature
LTCS	: Low Temperature Carbon Steel
MOV	: Motor Operated Valve
MP	: Magnetic Particle
MR	: Material Requisition
NDT	: Non Destructive Testing
PMI	: Positive Material Identification
PO	: Purchase Order
PR	: Purchase Requisition
RFQ	: Request for Quotation
SCRD	: Screwed
SS	: Stainless Steel
SW	: Socket Weld

Piping Standards Committee

Convenor : Mr M. Ismaeel

Members : Mr. Amrendra Kumar
Mr. G. Balaji
Mr. Udayan Chakravarty
Mr. K.J. Harinarayanan (S&ME)
Mr. S. Ghoshal (Process-2)
Mr. G.K. Iyer (Projects)
Mr. Pankaj Kumar Rai (Construction)



**PROCUREMENT OF VALVES FOR CONFIDENTIAL DEMO PLANT AT MRPL,
MANGALURU, KARNATAKA**

TENDER No.: 3200000897

**PROCUREMENT OF VALVES FOR CONFIDENTIAL DEMO
PLANT AT MRPL, MANGALURU, KARNATAKA**

SI No.	Contents	Page No.
1	General	184
2	Documentation	184-185
3	Design and Construction	185-188
4	Operation	189
5	Inspection and Testing	189-190
6	Radiography of Cast Valve	190-191
7	IBR Certification	191
8	Marking	191
9	Despatch	191
10	Attachments	192
11	References	192

PROCUREMENT OF VALVES FOR CONFIDENTIAL DEMO PLANT AT MRPL,
MANGALURU, KARNATAKA

1.0 GENERAL

1.1 Vendor shall supply valves in accordance with the valve specification sheets along with auxiliaries, if any, such as gear operator, bypasses, drains, locking arrangements etc. wherever specified in the specification sheets, subject notes and other enclosures to the material requisition (MR).

1.2 Vendor shall quote in strict accordance with the valve data / specification sheets, subject technical notes and all other enclosures to the MR. For 'Cat-I valves', no deviations whatsoever shall be accepted. Post Order Waiver/ Deviation format 5-0000-0180-F1 as mentioned in Cl. 5.17 of specification for Quality Management System Requirements from Bidder (6-78-0001) is not applicable for Cat-I valves. For Cat-II Valves, if exceptions/ deviations become absolutely must, the same shall be requested as explained in clause 2.3.6 giving reasons for seeking such exceptions/ deviations.

1.3 All codes and standards for manufacture, testing, inspection etc. shall be of latest editions as on issue date of RFQ.

2.0 DOCUMENTATION

2.1 All document submissions to EIL shall be through EIL eDMS.

2.2 For 'Cat-I' valves, no documents shall be submitted with the offer.

2.3 For 'Cat-II' valves, vendor shall submit the following documents with the offer:

2.3.1 Manufacturer's complete descriptive and illustrative catalogue / literature.

2.3.2 Detailed dimensioned cross section drawing with parts / material lists, weight etc.

2.3.3 Drawings for valves with accessories like gear operator, hydraulic / pneumatic operator, motor, extension bonnet, extended stems with stands, bypass etc. giving major salient dimensions.

2.3.4 One copy of the valve specification sheets signed as "Accepted" by the manufacturer. Deviations, if any shall be marked as applicable on the valve specification sheet.

2.3.5 If the valve is regretted or has no deviation, the manufacturer shall write clearly on valve specification sheets as "Regret" or "No Deviation".

2.3.6 For 'CAT-II' valves, if there is any deviation, the same shall be listed clausewise.

2.3.7 On failure to submit documents as specified in clauses 2.1.1 to 2.1.6 above, the offer is likely to be rejected.

2.4 The following documents shall be submitted through eDMS of EIL after placement of the order:

2.4.1 For Cat-I valves to manufacturers' standard specified in MR/valve specification sheet, detailed dimensioned cross section drawing with parts, materials, weight, etc. shall be submitted for records/information.

**PROCUREMENT OF VALVES FOR CONFIDENTIAL DEMO PLANT AT MRPL,
MANGALURU, KARNATAKA**

- 2.4.2 For 'Cat-II' valves, Vendor shall submit for review drawings mentioned in clauses 2.1.2 & 2.1.3 before start of manufacture. No other drawings shall be submitted for review.
- 2.4.3 Test report shall be supplied for all mandatory tests as per the applicable code. Test reports shall also be furnished for any supplementary tests as specified in clauses 3.13, 3.14 & 3.15.
- 2.4.4 Material test certificates (physical properties, chemical composition & heat treatment report) of the pressure containing parts shall be furnished for the valves supplied. Material test certificates for the other parts shall also be furnished for verification during inspection.
- 2.5 In addition to submissions through EIL eDMS, Catalogues/Drawings shall be in submitted in hard copies (6 sets) and soft copies (2 CDs/DVDs) along with delivery for Purchaser's record for all categories/types of valves.

3.0 DESIGN AND CONSTRUCTION

- 3.1 Valve shall be designed, manufactured, tested, inspected and marked as per the manufacturing standards, design codes and standards indicated in the respective valve specification sheets. Any conflict between the requisition, enclosures, specification sheets and referred standards/codes shall be brought to the notice of the purchaser for clarifications and resolution, before proceeding with the manufacture. The purchaser's decision shall be final and binding to the vendor. The drawings submitted for review shall not include any deviations except as communicated in writing in Deviation permits. The Drawings shall be reviewed only for design and construction features.
- 3.2 All flanged valves shall have flanges integral (except forged valves) with the valve body. Flange face finish shall be normally specified in the valve specification sheet as 125 AARH etc. The interpretation for range of face finish shall be as follows:

Stock Finish	: 1000 μ in AARH max.
125 AARH	: Serrations with 125 to 250 μ in AARH
63 AARH	: 32 to 63 μ in AARH

- 3.3 For all weld end valves with bevel end as per ASME B16.25, the contour of bevel shall be as follows:

Material	Wall Thickness	Weld Contour
Carbon Steel (Except Low Temp. Carbon Steel)	Upto 22 mm	Figure 2 Type A
	> 22 mm	Figure 3 Type A
Alloy Steel, Stainless Steel & Low Temp. Carbon Steel	Upto 10 mm	Figure 4
	> 10 mm & Upto 25 mm	Figure 5 Type A
	> 25 mm	Figure 6 Type A

Valve ends shall match thickness of the connecting pipe. Sloping of inside contour of valves shall be done wherever necessary to achieve this.

**PROCUREMENT OF VALVES FOR CONFIDENTIAL DEMO PLANT AT MRPL,
MANGALURU, KARNATAKA**

3.4 For flanged valves with ring joint flanges the hardness shall be as follows:

Flange Material	Min. Hardness of Groove (BHN)
Carbon Steel	140
1% Cr to 5% Cr, 9% Cr	150
Type 304, 316, 321, 347	160
Type 304L, 316L	140

3.5 Following requirements for check valves shall be met over and above the valve specification sheet requirements:

3.5.1 Unless specified otherwise in the data sheet all check valves 3" & above (except in 900#, 1500# & 2500# rating) shall have a drain boss at location "G" (Refer Fig.No.1 of ASME B16.34) where pocket is formed in valve body. A tapped drain hole with plug shall be provided as per ASME B16.34. Threads shall be as per ASME B1.20.1 (Taper) NPT.

3.5.2 For heavy check valves, provisions shall be available for lifting by way of lugs, eye bolts and other such standard devices.

3.6 If an overlay weld-deposit is used for the body seat ring seating surface, the corrosion resistance of the seat ring base material shall be at least equal to the corrosion resistance of the material of the shell.

3.7 Following valve bypass requirements shall be met:

3.7.1 By-pass requirement for Gate valves shall be as follows unless otherwise mentioned.

ASME 150 Class	On sizes 26" and above
ASME 300 Class	On sizes 16" and above
ASME 600 Class	On sizes 6" and above
ASME 900 Class	On sizes 4" and above
ASME 1500 Class	On sizes 4" and above
ASME 2500 Class	On sizes 3" and above

3.7.2 The by-pass piping arrangement shall be such that clearance between main valve body and by-pass assembly shall be the minimum possible for layout reasons. Vendor shall follow the sketch enclosed in Specification No. 6-44-0052-A1.

3.7.3 By-pass valve shall be a globe valve. The sizes shall be as under:

On main valve ≤ 4"	:	1/2"
On main valve 6" to 8"	:	3/4"
On main valve 10" & above	:	1"

By-pass piping shall be of same metallurgy as main valve. The by-pass piping, fittings and valve tag numbers shall be as specified in Specification No. 6-44-0052-A2. In case details of by-pass arrangement for any Valve tag number is missing, Vendor shall bring the same to notice of EIL and provide by-pass as per details specified.

3.7.4 Vendor shall supply the by-pass valve duly tested and fitted to the main valve. Valves with by-pass shall have the direction of flow marked on the main valve. By-pass attachment to the

PROCUREMENT OF VALVES FOR CONFIDENTIAL DEMO PLANT AT MRPL,
MANGALURU, KARNATAKA

main valve body shall not be screwed. All fillet welds for by-pass installation shall be 100% examined by DP/MP test and Butt-weld joints shall be 100% examined by radiography.

- 3.8 Valve body / bonnet shall be forged / cast as specified. Forgings are acceptable in place of casting but not vice-versa.
- 3.9 Stem shall be forged or machined from forged / rolled bar. No casting is permitted. However, integral stem of cast material is acceptable for Plug valves.
- 3.10 Stellite / hardfacing by deposition, shall be minimum 1.6 mm.
- 3.11 Renewable seat rings shall be seal welded for valves of size 3" and above to prevent loosening in service.
- 3.12 For Low Temperature & Cryogenic valve requirements, refer Specification.No.6-44-0052-A3 unless otherwise specified.
- 3.13 For Hydrogen service valve requirements, refer Specification.No.6-44-0052-A4 unless otherwise specified.
- 3.14 Valves under 'NACE' category shall meet the requirements specified in MR-0103 unless otherwise specified.
- 3.15 For all austenitic stainless steel valves Inter Granular Corrosion (IGC) test shall be conducted as per the following:
- 3.15.1 ASTM A262 Practice 'B' with acceptance criteria of '60 mils/year (max.)' for all materials - forged, rolled, wrought and casting.
- Or
- ASTM A262 Practice 'E' with acceptance criteria of 'No cracks as observed from 20X magnification' for all materials other than castings. 'Microscopic structure to be observed from 250X magnification' in addition.
- 3.15.2 When specifically asked for in MR for high temperature application of some grades of austenitic stainless steel (eg. SS309, 310, 316, 316H etc.) ASTM A262 Practice 'C' with acceptance criteria of '15 mils/year (max.)' shall be conducted.
- 3.15.3 For the IGC test as described in Clauses 3.15.1 & 3.15.2, two sets of samples shall be drawn from each solution annealing lot. One set shall correspond to the highest Carbon content and the other to the highest pressure rating. When testing is conducted as per practice 'E', photograph of the microscopic structure shall be submitted for record.
- 3.16 All types of 321 or 347 stainless steel valves shall be in a stabilised heat treated condition. Stabilising heat treatment shall be carried out subsequent to the normal solution annealing. Soaking temperature and holding time for stabilising heat treatment shall be 900°C and 4 hours respectively.
- 3.17 Spiral wound bonnet gaskets are to be provided with inner/outer ring except when encapsulated gaskets type body-bonnet joints are employed. Outer ring may be avoided in case of non-circular spiral wound gasket used in 150# valve provided the outermost layer of spiral touches the bolts ascertaining the centering.
- 3.18 All Stainless Steel Castings shall be solution heat treated.

PROCUREMENT OF VALVES FOR CONFIDENTIAL DEMO PLANT AT MRPL,
MANGALURU, KARNATAKA

3.19 Only normalized and tempered material shall be used in the following specifications :

Castings : A217 Gr.WC1, A217 Gr.WC4, A217 Gr.WC5, A217 Gr.WC6, A217 Gr.WC9, A217 Gr.C5, A217 Gr.C12

Forgings : A182 Gr.F11 Cl.2, A182 Gr.F12 Cl.2

3.20 Ball / Plug / Butterfly Valves

3.20.1 As a prequalification, fire safe test as per API 607 / API 6FA / BS EN ISO 10497 (Supersedes BS 6755 Part II) shall be carried out on soft seated ball, plug & butterfly valves and also on lubricated plug valves. The test shall be witnessed and certified by a third party inspection agency like Lloyds, BVIS, DNV or EIL/ CEIL unless otherwise specified. The vendor has to submit test certificate for the particular design of the valve offered, if fire safe design is required as per the Valve Material Specification sheet.

3.20.2 Each valve shall be supplied with a lever / wrench except for gear operated / motor operated valves.

3.20.3 Soft-seated ball, plug & butterfly valves shall be supplied with antistatic devices.

3.20.4 BW / SW end ball valves shall have a 100 mm long seamless pipe nipple welded to each end of the valve. Nipples are to be welded prior to assembling Teflon seats / seals. Specifications of the nipples shall be as indicated in the MR.

3.20.5 The face-to-face dimensions of all ball valves shall be same as those of gate valves of the corresponding ANSI class (except 10" onwards in Class 150 where the face-to-face dimensions shall be as per API 6D long pattern).

3.20.6 The ball of ball valve shall not protrude outside the end flanges of valve.

3.20.7 Ball valves shall be of floating ball/trunnion mounted type as per following:

150#	8" & below	Floating ball
	10" & above	Trunnion mounted
300#	4" & below	Floating ball
	6" & above	Trunnion mounted
600#	1.5" & below	Floating ball
	& above 2" & above	Trunnion mounted

3.20.8 Unless otherwise specified in the data sheets, bore of all reduced bore ball valves shall be limited to one size lower than the nominal bore.

3.21 The MOVs are to be installed in an open area and the actuators shall be suitable for all weather conditions. The testing of complete assemblies of MOVs along with the actuators shall be done by the supplier at his works.

3.22 Ends of flanged valves of 22" size shall match corresponding flanges to MSS-SP44 unless otherwise specified.

3.23 Yoke material shall be same as bonnet material where maximum temperature specified is more than 427°C.

4.0 OPERATION

4.1 Gear operation shall be provided as under:

Valve Type	Class	Size Requiring Gear-Operator
Gate Valve, Globe Valve & Diaphragm Valve	150 Class	12" and larger
	300 Class	12" and larger
	600 Class	10" and larger
	900 Class	6" and larger
	1500 Class	3" and larger
	2500 Class	3" and larger
Ball Valve / Plug Valve (Other than pressure balance plug valves)	150 Class	6" and larger
	300 Class	6" and larger
	600 Class	4" and larger
	900 Class	3" and larger
	1500 Class	3" and larger
Butterfly Valve	150, 300 Class	6" and larger

For sizes lower than these ranges, hand wheel / lever / wrench shall be provided. For pressure balance plug valves manufacturer's recommendation shall be acceptable provided the requirements specified in clause 4.6 are met.

- 4.2 Gear operator shall be provided, with position indicators for open / close positions and with limit stops. (Limit stops are not applicable for gate and globe valves)
- 4.3 Where gear operator is not called for as per Clause 4.1 but vendor recommends a gear operator, the same shall be highlighted.
- 4.4 Gear operator shall be so designed as to operate effectively with the differential pressure across the closed valve equal to the cold non-shock pressure rating.
- 4.5 Ball, plug and butterfly valves, shall have "Open" position indicators with limit stops.
- 4.6 Hand wheel diameter shall not exceed 750mm and lever length shall not exceed 500mm on either side. Effort to operate shall not exceed 35 Kg at handwheel periphery. However, failing to meet the above requirements, vendor shall offer gear operated valve and quote as per clause 4.3.

5.0 INSPECTION AND TESTING

- 5.1 Every valve shall be subjected to all the mandatory tests and checks called in the respective codes / data sheet by EIL inspection or any third party as approved by the purchaser. For IBR valves refer clause 7.0.
- 5.2 Every valve, its components and auxiliaries must be subjected to all the mandatory tests and checks called for in the respective codes, data sheets etc. by the manufacturer.
- 5.3 Though the extent of inspection shall be as under, exact extent with hold points shall be decided by EIL regional inspection office and recorded in the form of inspection plan. In case of third party inspection, the inspection plan shall be approved by the purchaser.

**PROCUREMENT OF VALVES FOR CONFIDENTIAL DEMO PLANT AT MRPL,
MANGALURU, KARNATAKA**

Forged Valves:

1. Visual and dimensional inspection.
2. Review of material test certificates.
3. Any mandatory or supplementary test.
4. Hydrostatic test on 10% valves selected on random basis.
5. Strip check is required for 1% of total ordered quantity of Gate & Globe valves (min. 1 No.) for each Valve sheet no., however, strip check is not required for CS/ Brass/ Bronze material valves with 13% Cr/ Brass/ Bronze trims.

Cast Steel Valves:

1. Visual and dimensional inspection.
2. Review of material test certificates.
3. Review of radiographs/radiographic reports or any other NDT tests wherever applicable as per data sheet.
4. Any mandatory or supplementary test.
5. Hydrostatic test 100% for body, 10% other test.
6. Strip check is required for 1% of total ordered quantity of Gate & Globe valves (min. 1 No.) for each Valve sheet no., however, strip check is not required for CS/ Brass/ Bronze material valves with 13% Cr/ Brass/ Bronze trims.

Samples for strip check shall be selected at random and shall generally be in the highest size in the lot.

- 5.4** In case of motor operated or actuator operated valves, functional / operational checks as per the requirements of the specifications shall be made on each valve.

6.0 RADIOGRAPHY OF CAST VALVES

- 6.1** Valve castings shall undergo radiographic examination as specified below.

Material	Rating	Size Range	Radiography
All	150#	24" and below	NIL**
		26" and above*	100%
	300#	16" and below	NIL**
		18" and above	100%
600# & above	All sizes	100%	

* No radiography is required for valves of size 26" and above in cooling water service.

**For sizes 24" & below in 150# and 16" & below in 300#, radiography percentage if specifically mentioned in individual valve material spec sheet shall govern.

Radiography specified as random 10% or 20% etc. in the respective valve data sheet implies 10% or 20% etc. of number of valves ordered against each item number with a minimum of one valve against each item.

**PROCUREMENT OF VALVES FOR CONFIDENTIAL DEMO PLANT AT MRPL,
MANGALURU, KARNATAKA**

- 6.2 Radiography procedure, areas of casting to be radiographed shall be as per ASME B16.34 and acceptance criteria shall be as per ASME B16.34 Annexure-B. However for areas of casting to be radiographed for types of valves not covered in ASME B16.34, vendor shall radiograph castings in line with ASME B16.34.
- 6.3 For random radiography wherever specified in individual data sheets, the sampling shall be per size of the quantity ordered for each foundry.
- 6.4 Radiography wherever specified in the data sheets or as per clause 6.1 shall be done by X-ray / γ -ray to get the required sensitivity.

7.0 IBR CERTIFICATION

- 7.1 For valves described "IBR", valves shall be in accordance with the latest IBR (Indian Boiler Regulation) including the requirements specified in the specification.
- 7.2 For SW / BW end carbon steel valves under IBR, the chemical composition shall conform to the following:

Carbon (Max)	:	0.25%
Others (S, P, Mn)	:	As per IBR

- 7.3 Valves coming under the purview of "IBR"(Indian Boiler Regulations) shall each be individually accompanied by IBR certificate original in Form III-C duly approved by IBR authority / local authority empowered by the Central Boiler Board of India. Photocopy of original certificate duly attested by the local boiler inspector where the supplier is located is the minimum requirement for acceptance.
- 7.4 All "IBR" valves shall be painted red in body-bonnet / body-cover joint.

8.0 MARKING

- 8.1 Valve markings, symbols, abbreviations etc. shall be in accordance with MSS-SP-25 or the standard referred in specification sheet as applicable. Vendor's name, valve rating, material designation, nominal size, direction of flow (if any) etc. shall be integral on the body.
- 8.2 Each valve shall have a corrosion resistant tag giving size, valve tag / code no., securely attached to the valve body.
- 8.3 Paint or ink for marking shall not contain any harmful metal or metal salts such as zinc, lead or copper which cause corrosive attack on heating.
- 8.4 Carbon Steel / Alloy Steel valves shall be painted with one coat of inorganic zinc silicate (minimum DFT 65 to 75 microns).

9.0 DESPATCH

- 9.1 Valve shall be dry, clean and free from moisture, dirt and loose foreign materials of any kind.
- 9.2 Valves shall be protected from rust, corrosion and any mechanical damage during transportation, shipment and storage.



PROCUREMENT OF VALVES FOR CONFIDENTIAL DEMO PLANT AT MRPL,
MANGALURU, KARNATAKA



TECHNICAL NOTES
FOR VALVES

STANDARD SPECIFICATION No.

6-44-0052 Rev.7

Page 12 of 12

- 9.3 Rust preventive on machined surfaces to be welded shall be easily removable with a petroleum solvent or shall not be harmful to welding.
- 9.4 Each end of valve shall be protected with the following materials:
- | | | |
|-----------------|---|-----------------------|
| Flange Face | : | Wood or Plastic Cover |
| Bevelled End | : | Wood or Plastic Cover |
| SW & SCR.D. End | : | Plastic Cap |
- 9.5 End protectors of wood / plastic to be used on flange faces shall be attached by at least three bolts and shall not be smaller than the outside diameter of the flange. However, plastic caps for SW & SCR.D. end valves shall be press fit type.
- 9.6 End protectors to be used on bevelled end shall be securely and tightly attached.
- 9.7 For special service valves additional requirement for despatch shall be as prescribed in data sheet.
- 10.0 ATTACHMENTS**
- | | | |
|--------------|---|---|
| 6-44-0052-A1 | : | Bypass Piping Arrangement |
| 6-44-0052-A2 | : | Specifications for Bypass Piping, Fittings and Valves |
| 6-44-0052-A3 | : | Special Requirements for Low Temperature and Cryogenic Valves |
| 6-44-0052-A4 | : | Special Requirements for Hydrogen Service Valves |
- 11.0 REFERENCES**
- | | | |
|-----------|---|--|
| 6-78-0001 | : | Specification for Quality management system requirements from bidders |
| 6-78-0003 | : | Specification for documentation requirements from suppliers |
| 6-81-0001 | : | Specification for Positive Material Identification (PMI) at Supplier's Works |
| 6-81-0004 | : | Inspection and Test plan for Valves |

BYPASS PIPING ARRANGEMENT

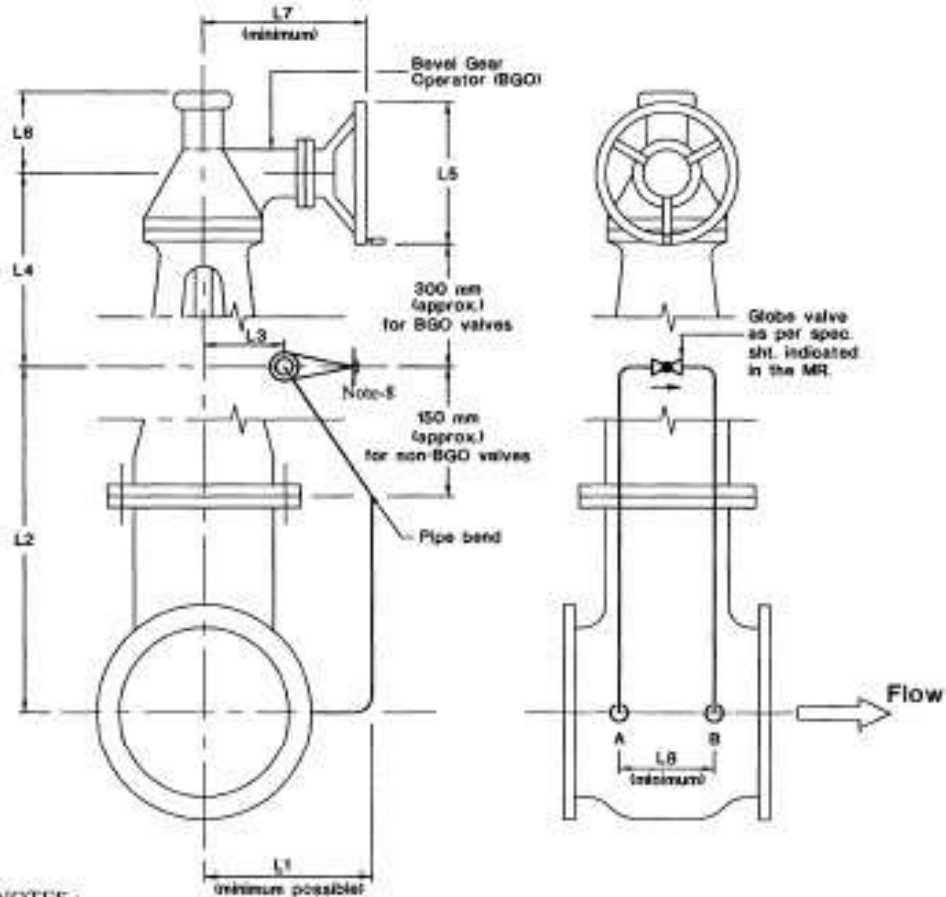

NOTES :

1. The orientation & location of handwheel of bevel gear operator & the bypass arrangement shall be strictly as per this sketch.
2. The bypass connection ends shall be socket welded upto 600# and butt welded for 900# and above rating.
3. The bypass arrangement shall be properly clamped to & supported by the body of the main valve.
4. Basic design of bypass shall be to MSS-SP-45.
5. Material of bypass pipe & 90° elbows shall be same or equivalent to the body material as indicated in Specification No. 6-44-0052-A2.
6. This sketch is applicable for both BGO & NON-BGO Valves.
7. Vendor shall furnish dimensions L1 to L8.
8. Stem shall not be horizontal in the case of CRYO Valves.

**PROCUREMENT OF VALVES FOR CONFIDENTIAL DEMO PLANT AT MRPL,
MANGALURU, KARNATAKA**

SPECIFICATIONS FOR BYPASS PIPING, FITTINGS AND VALVES

Class (Main Valve Sht.no.)	Pipe	Fittings	Bypass Valve Sht.no.
A1A(51301), A3A(51321), A9A(51301), A10A(51301), A11A(51301), A33A(51301), B1A(51401), B9A(51401), D1A(51501), D9A (51501)	ASTM A106 Gr.B (SMLS) 0.5"-0.75": S160 1.0"-1.5" : XS	ASTM A105 0.5"-0.75": SW 6000# 1.0"-1.5" : SW 3000#	52001
A6A(51301), B6A(51401)	ASTM A106 Gr.B (SMLS) 0.5"-0.5" : XXS 0.75"-1.5": S160	ASTM A105 0.5"-0.5" : SW 9000# 0.75"-1.5": SW 6000#	52001
A13A(51301), B13A(51401)	ASTM A106 Gr.B (SMLS) 0.5"-1.5" : XXS	ASTM A105 0.5"-1.5" : SW 9000#	52001
A2A(51302), B2A(51402), D2A (51502)	ASTM A106 Gr.B (SMLS)- IBR 0.5"-0.75": S160 1.0"-1.5" : XS	ASTM A105 - IBR 0.5"-0.75": SW 6000# 1.0"-1.5" : SW 3000#	52002
A4A (51303), B4A (51403), D4A (51503)	ASTM A333 Gr.6 (SMLS)- LT 0.5"-0.75": S160 1.0"-1.5" : XS	ASTM A350Gr.LF2- LT 0.5"-0.75": SW 6000# 1.0"-1.5" : SW 3000#	52003
A5A (51304), B5A (51404), D5A (51504)	ASTM A106 Gr.B (SMLS)-H2 0.5"-0.75": S160 1.0"-1.5": XS	ASTM A105 - H2 0.5"-0.75": SW 6000# 1.0"-1.5" : SW 3000#	52004
A7A (51307)	ASTM A106 Gr.B (SMLS) 0.5"-0.75": S160 1.0"-1.5": XS	ASTM A105 0.5"-0.75": SW 6000# 1.0"-1.5" : SW 3000#	52007
A16A (51311), B16A (51411), D16A (51511)	ASTM A106 Gr.B (SMLS) - NACE 0.5"-0.5" : XXS 0.75"-1.5": S160	ASTM A105 - NACE 0.5"-0.5" : SW 9000# 0.75"-1.5": SW 6000#	52011
A19A (51313), B19A (51413), D19A (51513)	ASTM A106 Gr.B (SMLS) 0.5"-0.75": S160 1.0"-1.5": XS	ASTM A105 0.5"-0.75": SW 6000# 1.0"-1.5" : SW 3000#	52013
E1A (51601), F1A (51701)	ASTM A106 Gr.B (SMLS) 0.5"-1.5" : S160	ASTM A234 Gr.WPB/ ASTM A105 0.5"-1.5" : BW, S160	52101
E2A (51602), F2A (51702)	ASTM A106 Gr.B (SMLS) - IBR 0.5"-1.5" : S160	ASTM A234 Gr.WPB/ ASTM A105 - IBR 0.5"-1.5" : BW, S160	52102
E5A (51604), F5A (51704)	ASTM A106 Gr.B (SMLS) - H2 0.5"-1.5" : S160	ASTM A234 Gr.WPB/ ASTM A105 - H2 0.5"-1.5" : BW, S160	52104
E9A (51605), F9A (51705)	ASTM A106 Gr.B (SMLS) 0.5"-1.5" : SCH XXS	ASTM A234 Gr.WPB/ ASTM A105 0.5"-1.5" : BW, SCH XXS	52105
E19A (51613), F19A (51713)	ASTM A106 Gr.B (SMLS) 0.5"-1.5" : SCH XXS	ASTM A234 Gr.WPB/ ASTM A105 0.5"-1.5" : BW, SCH XXS	52113

**PROCUREMENT OF VALVES FOR CONFIDENTIAL DEMO PLANT AT MRPL,
MANGALURU, KARNATAKA**

Class (Main Valve Sht.no.)	Pipe	Fittings	Bypass Valve Sht.no.
A5Y (51384), A33Y (51384)	ASTM A106 Gr.B (SMLS) 0.5"-1.5" : S160	ASTM A105 0.5"-1.5" : SW 6000#	52085
A1D (51330), B1D (51430), D1D (51530)	ASTM A335Gr.P11(SMLS) 0.5"-0.75" : S160 1.0"-1.5" : XS	ASTM A182 Gr.F11Cl.2 0.5"-0.75" : SW 6000# 1.0"-1.5" : SW 3000#	52030
D2D (51531)	ASTM A335Gr.P11 (SMLS) - IBR 0.5"-0.75" : S160 1.0"-1.5" : XS	ASTM A182 Gr.F11Cl.2 - IBR 0.5"-0.75" : SW 6000# 1.0"-1.5" : SW 3000#	52031
B5D (51432), D5D (51532)	ASTM 335Gr.P11(SMLS)- H2 0.5"-0.75" : S160 1.0"-1.5" : XS	ASTM A182 Gr.F11Cl.2 - H2 0.5"-0.75" : SW 6000# 1.0"-1.5" : SW 3000#	52032
B1E (51433)	ASTM A335Gr.P22(SMLS) 0.5"- 0.75" : S160 1.0"-1.5" : XS	ASTM A182 Gr.F22Cl.3 0.5"-0.75" : SW 6000# 1.0"-1.5" : SW 3000#	52033
D5E (51534)	ASTM A335Gr.P22(SMLS) - H2 0.5"-0.75" : S160 1.0"-1.5" : XS	ASTM A182 Gr.F22Cl.3 - H2 0.5"-0.75" : SW 6000# 1.0"-1.5" : SW 3000#	52034
A4F (51336), B4F (51436)	ASTM A335 Gr.P5(SMLS) 0.5"-0.75" : S160 1.0"-1.5" : XS	ASTM A182 Gr.F5 0.5"-0.75" : SW 6000# 1.0"-1.5" : SW 3000#	52036
B3F (51436)	ASTM A335 Gr.P5(SMLS) 0.5"-1.5" : XXS	ASTM A182 Gr.F5 0.5"-1.5" : SW 9000#	52036
A4G (51339), B4G (51439)	ASTM A335 Gr.P9(SMLS) 0.5"-0.75" : S160 1.0"-1.5" : XS	ASTM A182 Gr.F9 0.5"-0.75" : SW 6000# 1.0"-1.5" : SW 3000#	52039
F2D (51731)	ASTM A335 Gr.P11 (SMLS) - IBR 0.5"-1.5" : S160	ASTM A234Gr.WP11Cl.1/ A182 Gr.F11Cl.2 - IBR 0.5"-1.5" : BW, S160	52131
E5E (51634)	ASTM A335 Gr.P22(SMLS) - H2 0.5"-0.75" : S160 1.0"-1.5" : XS	ASTM A234Gr.WP22Cl.1/ A182 Gr.F22Cl.3 - H2 0.5"-0.75" : BW, S160 1.0"-1.5" : BW, XS	52134
A1K (51345), A3K (51345), B1K (51445), D1K (51545)	ASTM A312 TP304(SMLS) 0.5"-0.75" : 80S 1.0"-1.5" : 40S	ASTM A182 Gr.F304 0.5"-1.5" : SW 3000#	52045
A2K (51346), B2K (51446), D2K (51546)	ASTM A312 TP304(SMLS) - CRYO 0.5"-0.75" : 80S 1.0"-1.5" : 40S	ASTM A182 Gr.F304 - CRYO 0.5"-1.5" : SW 3000#	52046
B4K (51448), B5K (51448)	ASTM A312 TP304H (SMLS) 0.5"-1.5" : 80S	ASTM A182 Gr.F304H 0.5"-1.5" : SW 3000#	52048



PROCUREMENT OF VALVES FOR CONFIDENTIAL DEMO PLANT AT MRPL,
MANGALURU, KARNATAKA



SPECIFICATIONS FOR BYPASS
PIPING, FITTINGS AND VALVES

STANDARD SPECIFICATION No.
6-44-0052-A2 Rev.7
Page 3 of 3

Class (Main Valve Sht.no.)	Pipe	Fittings	Bypass Valve Sht.no.
A6K (51350), B6K (51450)	ASTM A312 TP304L (SMLS) 0.5"-0.75" : 80S 1.0"-1.5" : 40S	ASTM A182 Gr.F304L 0.5"-1.5" : SW 3000#	52050
A1M (51361), B1M (51461)	ASTM A312 TP316(SMLS) 0.5"-0.75" : 80S 1.0"-1.5" : 40S	ASTM A182 Gr.F316 0.5"-1.5" : SW 3000#	52061
B5M (51462)	ASTM A312 TP316H (SMLS) - H2 0.5"-0.75" : 80S 1.0"-1.5" : 40S	ASTM A182 Gr.F316H - H2 0.5"-1.5" : SW 3000#	52062
B3M (51463)	ASTM A312 TP321(SMLS) 0.5"-0.75" : 80S 1.0"-1.5" : 40S	ASTM A182 Gr.F321 0.5"-1.5" : SW 3000#	52063
A1N (51366), B1N (51466)	ASTM A312 TP 316L (SMLS) 0.5"-0.75" : 80S 1.0"-1.5" : 40S	ASTM A182 Gr.F316L 0.5"-1.5" : SW 3000#	52066
B6N (51471)	ASTM A312 TP316L (SMLS) 0.5"-0.75" : 80S 1.0"-1.5" : 40S	ASTM A182 Gr.F316L 0.5"0.5"-1.5" : SW 3000#	52071

**PROCUREMENT OF VALVES FOR CONFIDENTIAL DEMO PLANT AT MRPL,
MANGALURU, KARNATAKA**

SPECIAL REQUIREMENTS FOR LOW TEMPERATURE & CRYOGENIC VALVES

1.0 SCOPE

All valves of Low Temperature Carbon Steel (LTCS) and all grades of austenitic SS (CRYO) material are categorized as cryogenic valves. All these valves shall have extended bonnet as per BS 6364 except check valves.

Following qualification criteria shall be met by the valve vendors to quote valves for cryogenic services:

2.0 QUALIFICATION CRITERIA

- i) Both cryogenic test (clause 2.1) and reference list (clause 2.2) together shall be considered for vendor qualification and vendor shall furnish the same, along with his offer.
- ii) Vendors who do not have cryogenic test reports and reference list covering valves of all sizes, materials and ratings required by MR, should confirm / furnish the following for consideration of their offer:
 - a. Evidence of having conducted successfully at least one cryogenic test as per BS 6364. Test certificate shall be furnished with the offer.
 - b. Vendor shall confirm to conduct cryogenic test per clauses 2.1 & 2.3 for the remaining valves not later than 12 weeks from the date of purchase order.
 - c. Vendor shall also furnish reference list for valves supplied for non-cryo service if reference list referred in 2.2.1 does not cover all the sizes of MR.

Offers of vendors who do not comply with above requirements would be rejected.

2.1 Cryogenic Test

Vendors to furnish copies of cryogenic test certificate for tests conducted as per details given below:

- 2.1.1 Test shall be as per BS 6364.
- 2.1.2 Test temperature, unless specifically called for otherwise in the individual MR, shall be -45°C for LTCS and -196°C for all grades of austenitic stainless steel.
- 2.1.3. Tests carried out on a particular size of one type of valve, pressure rating and material shall qualify all sizes equal to and below the test valve size for the same type, pressure rating and material. In case of austenitic SS any one grade would qualify for all other grades of austenitic SS.
- 2.1.4. Tests should have been witnessed and certified by any one of the following third party inspection agencies; M/s Lloyd, BV, DNV, TUV or EIL/ CEIL.
- 2.1.5. Cryogenic test need not be conducted for every order. Test conducted previously and witnessed by inspection agencies listed above shall be considered acceptable and need not be repeated.



PROCUREMENT OF VALVES FOR CONFIDENTIAL DEMO PLANT AT MRPL,
MANGALURU, KARNATAKA



SPECIAL REQUIREMENTS FOR
LOW TEMPERATURE &
CRYOGENIC VALVES

STANDARD SPECIFICATION No.

6-44-0052-A3 Rev.7

Page 2 of 2

2.2 Reference List

Vendor shall furnish reference list for valves supplied for cryogenic service indicating the name of client, year of supply, size, material, pressure rating, type of valve and quantity.

2.3 Post Order Testing Procedure

2.3.1. Before conducting post order testing, vendor shall submit the following for approval:

- Test procedure (as per BS 6364).
- Cross-section drawing of the valve with material of construction.
- Schematic of test rig (as per BS 6364) with complete details.

2.3.2. Test has to be conducted irrespective of the service on largest size for each type of valve and for each material and class rating. Vendor shall offer one, two or three valves for selection of test valve by inspector depending upon whether quantity of largest valve in the order is one, two or three and more than three respectively.

In the event of failure of the test valve to meet the specification requirements, the vendor shall conduct test on two more valves. These two valves which pass test successfully, are of lower size, then the qualification will be valid only to sizes upto which test has been conducted successfully.

2.3.3. In case of non-conductance of cryogenic test(s) within 12 weeks or failure in the test(s) conducted after receipt of order, the owner reserves the right to invoke any of the provisions of the purchase order including cancellation of the purchase order at the risk and cost of vendor.

3.0 Bonnet extension, wherever specified in the valve sheet to BS 6364 shall be for "non cold box application" unless otherwise specified in the MR. Even if not called for in valve sheet, valves indicated as "LT" or "CRYO" shall be supplied with bonnet extension.

4.0 Bonnet and Gland extension joints shall be of butt welded/integrally cast construction.

5.0 Repair welding procedure for austenitic stainless steel valves in "CRYO" service shall have to be qualified for impact test as per ASME B31.3. Minimum acceptable impact energy shall be 20 J or lateral expansion of 0.38 mm at temperature of -196°C.

6.0 Wherever impact test of SS studs / nuts is called for in the data sheet, the impact value shall be 27 J at the intended service temperature specified in the data sheets.

**PROCUREMENT OF VALVES FOR CONFIDENTIAL DEMO PLANT AT MRPL,
MANGALURU, KARNATAKA**

SPECIAL REQUIREMENTS FOR HYDROGEN SERVICE

1.0 GENERAL

1.1 These requirements are applicable for valves used in Hydrogen service. These are in addition to the requirements described in "Technical Notes for Valves" Spec. No. 6-44-0052, and shall be read in conjunction with this specification.

1.2 All cast valve flanges & bodies with flange rating of Class 900 or greater shall be examined in accordance with paragraphs 7.2 through 7.5 of Appendix-VII of ASME SEC-VIII, DIV.1, regardless of casting quality factor.

1.3 Body / bonnet / cover joints & stuffing box of all valves shall have low emission. One valve per metallurgy, per rating, per size shall be helium leak tested as per ASME Sec.V, Subsection A, Article 10 (Detector Probe Technique), Appendix IV at a minimum of 25% of the allowable (rated) cold working pressure. Selection of valves for helium leak test shall be at random. Test duration shall be as follows:

Test Duration in Minutes					
Nominal Size	Pressure Class				
	Upto 300	600	800 & 900	1500	2500
Upto 2"	3	6	9	12	12
3" to 6"	6	9	12	15	18
8" to 16"	9	9	12	15	18
18" to 24"	9	12	15	18	21

The valve shall show no leakage. No leakage is defined as a total leakage rate of less than 0.0001 ml/s of helium.

2.0 Only normalized and tempered material shall be used in the following specifications:

Castings : A217 Gr.WC1, A217 Gr.WC4, A217 Gr.WC5, A217 Gr.WC6, A217 Gr.WC9, A217 Gr.C5, A217 Gr.C12

Forgings : A182 Gr.F11 Cl.2

3.0 CS & AS VALVES

3.1 Bend test and Magnetic Particle inspection of the entire surface of body and bonnet casting shall be in accordance with ASTM A217. Supplementary requirement S3 & S4 evaluation of magnetic particle, inspection shall be in accordance with MSS-SP-53 except that no linear discontinuities shall be allowed.

3.2 The Brinell hardness of heat treated casting shall not exceed 200 BHN for carbon steel & 225 for alloy steel.

3.3 Repair to defective casting shall be outlined in writing to the purchaser before repair starts. Repair method to be approved prior to welding.

3.4 Casting shall be preheated to a minimum of 400°F prior to welding and all Chromium-Molybdenum alloys shall be postweld heat treated after welding is complete. Stress relieving is essential for welds.



PROCUREMENT OF VALVES FOR CONFIDENTIAL DEMO PLANT AT MRPL,
MANGALURU, KARNATAKA



SPECIAL REQUIREMENTS FOR
HYDROGEN SERVICE VALVES

STANDARD SPECIFICATION No.

6-44-0052-A4 Rev.7

Page 2 of 2

- 3.5 Carbon steel shall be normalised and alloy steels shall be normalised & tempered.
- 3.6 Dye Penetrant test of welds shall be in accordance with ASTM B165 Procedure B-2. Interpretation as per Appendix-8 of ASME-VIII Div.1.
- 3.7 The tensile stress for AS shall be less than 100,000 psi.
- 3.8 Charpy V-notch impact testing is to be done for valve material (average 20 ft-lb for set of 3 [minimum value 15 ft-lb] at 30°F).
- 3.9 For radiography and acceptance criteria for valve castings, refer Cl. 4.2.
- 4.0 **SS VALVES**
- 4.1 Valve casting shall be in solution heat treated and pickled condition.
- 4.2 Critical body and bonnet casing section typically defined by ASME B16.34 shall be radiographed and shall meet ASTM E446 (upto 2" thick) Category A, B & CA Level 2, Category CB, OC & CD Level 3, Category D, B & F Level 0. For wall thickness 2" to 4.5" comparable plates of ASTM E186 shall be used. ASTM E94 and ASTM E142 shall be used for recommended practice & controlling quality of radiography as guide. The entire surface of all castings shall be dye-penetrant inspected after pickling.
- 4.3 Welds shall be 100% radiographed and evaluated in accordance with paragraph 344.5 of ASME B31.3 with a minimum casting quality factor of 0.95. Dye Penetration test shall be as per ASTM E165 Procedure B-2, Interpretation as per Appendix-8 of ASME-VIII Div.1.

STANDARD SPECIFICATION NO
6-81-0004 Rev. 6
Page 1 of 7

INSPECTION AND TEST PLAN
FOR
VALVES

इंजीनियर्स
इंडिया लिमिटेड
ENGINEERS
INDIA LIMITED
(A Govt. of India Undertaking)

वाल्वों के लिये
निरीक्षण व परीक्षण योजना

INSPECTION AND TEST PLAN
FOR
VALVES

6	14 11 2018	REVISED AND RE-ISSUED	KC	NMI	KS	RKT
5	17 06 2013	REVISED AND RE-ISSUED	TKK	RKS	SCG	DM
4	15 07 2011	REVISED AND RE-ISSUED	TKK	SCG	AKC	DM
3	30 06 2010	REVISED AND RE-ISSUED	RKB	VKJ	SKP	ND
2	31 01 2008	REVISED AND RE-ISSUED	CS	SS	MVKK	VC
Rev No	Date	Purpose	Prepared by	Checked by	Standards Committee Convener	Standards Bureau Chairman
						Approved by

Copyright EIL - All rights reserved

Format No 8-00-0001-F7 Rev 0

INSPECTION AND TEST PLAN
FOR
VALVES

Abbreviations:

CEIL	:	Certification Engineers International Limited	MRT	:	Mechanical Run Test
CIMFR	:	Central Institute of Mining & Fuel Research	NDT	:	Non Destructive Testing
CE	:	Carbon Equivalent	NPSH	:	Net Positive Suction Head
DFT	:	Dry Film Thickness	PO	:	Purchase Order
DPT	:	Dye Penetrant Testing	PESO	:	Petroleum Explosive Safety Organization
DHT	:	De-hydrogen Heat Treatment	PQR	:	Procedure Qualification Record
ERTL	:	Electronics Regional Test Laboratory	PR	:	Purchase Requisition
FCRI	:	Fluid Control Research Institute	PMI	:	Positive Material Identification
HT	:	Heat Treatment	RT	:	Radiography Testing
HIC	:	Hydrogen Induced Cracking	SSCC	:	Sulphide Stress Corrosion Cracking
ITP	:	Inspection and Test Plan	TC	:	Test Certificate
IP	:	Ingress Protection	TPI or TPIA	:	Third Party Inspection Agency
IHT	:	Intermediate Heat Treatment	UT	:	Ultrasonic Testing
IC	:	Inspection Certificate	VDR	:	Vendor Data Requirement
IGC	:	Inter Granular Corrosion	WPS	:	Welding Procedure Specification
MPT/MT	:	Magnetic Particle Testing	WPQ	:	Welders Performance Qualification
MTC	:	Material Test Certificate			

Inspection Standards Committee

Convenor : Mr. R. K. Singh

Members:

Mr. Rajeev Kumar
Mr. T Kamalakannan

Mr. Neeraj Mathur
Mr. Mahendra Mittal

Mr. Himangshu Pal
Mr Deepak Gupta (Projects)

Mr R Muthu Ramalingam (RPO Rep.)

1.0 SCOPE

This Inspection and Test Plan covers the minimum testing requirements of Valves.

2.0 REFERENCE DOCUMENTS

PO/PR/Standards referred therein/ Job specifications /Approved documents.

3.0 INSPECTION AND TEST REQUIREMENTS

SL NO	STAGE / ACTIVITY	CHARACTERISTICS	QUANTUM OF CHECK	RECORD	SCOPE OF INSPECTION		
					SUB SUPPLIER	SUPPLIER	EIL/TPIA
1.0	Procedure						
1.1	Hydrostatic Test, Heat Treatment, NDT, Helium Leak Test and Other Procedures	Documented Procedures	100%	Procedure Documents	-	H	R
1.2	WPS, PQR & WPQ	Welding Parameters & Qualification Record	100%	WPS, PQR & WPQ	-	H	W- New R- Existing
1.3	Pre-Qualification Tests	Fire safe, Cryogenic & Other Test as applicable	As per PR / Purchase Specification	Acceptance Report	-	H	H (If new)

PROCUREMENT OF VALVES FOR CONFIDENTIAL DEMO PLANT AT MRPL,
MANGALURU, KARNATAKA

STANDARD SPECIFICATION NO.
6-81-0004 Rev. 6
Page 4 of 7

INSPECTION AND TEST PLAN
FOR
VALVES

श्री अरुण इंजीनियर्स
श्री अरुण इंडिया लिमिटेड
(A Govt. of India Undertaking)

SL NO	STAGE / ACTIVITY	CHARACTERISTICS	QUANTUM OF CHECK	RECORD	SCOPE OF INSPECTION		
					SUB SUPPLIER	SUPPLIER	EIL/TPIA
2.0	Material Inspection						
2.1	Castings & Forgings (Body, Bonnet, Disc, Stem, Body ring)	Chemical, Mechanical, Heat Treatment, NDT, IGC & Other Properties as applicable	100%	Test Certificates	H	R	R
2.2	Castings & Forgings (Body, Bonnet, Disc, Stem, Body ring)	Visual & Dimension	100%	Inspection Report	H	H	-
2.3	Body and Bonnet Castings	Radiography Examination	As per PR / Purchase Specification	Films and report	H	R	R
2.4	Bars for Trim material	Chemical Analysis	Each Heat	Test Certificates & Lab Report	H	R	-
2.5	Gaskets, Gear units, Fasteners, Gland, Packings, etc.	Physical / Chemical Properties	100%	Test Certificates & Lab Report	H	R	-
2.6	Actuators as applicable	Performance, Statutory Certificates as applicable	100%	Test Certificates, Inspection report	H	H	R

Format No 8-00-0001-F7 Rev 0

Copyright EIL – All rights reserved

PROCUREMENT OF VALVES FOR CONFIDENTIAL DEMO PLANT AT MRPL,
MANGALURU, KARNATAKA

STANDARD SPECIFICATION NO
6-81-0004 Rev. 6
Page 5 of 7

INSPECTION AND TEST PLAN
FOR
VALVES

इंजीनियर्स इंडिया लिमिटेड
ENGINEERS INDIA LIMITED
A Govt. of India Undertaking

SL NO	STAGE / ACTIVITY	CHARACTERISTICS	QUANTUM OF CHECK	RECORD	SCOPE OF INSPECTION		
					SUB SUPPLIER	SUPPLIER	EIL/TP/A
3.0	In Process Inspection						
3.1	Welding	Welding Parameters as per WPS / PQR	100%	Inspection Reports	-	H	-
3.2	Machining of components	Visual / Dimension	100%	Inspection Reports	-	H	-
4.0	Final Inspection						
4.1	Hydrostatic / Pneumatic Test and Helium Leak test as applicable	Leak Check	As per PR / Purchase Specification	Test Report	-	H	RW (Note 1)
4.2	Visual / Dimension	Surface & Dimension Check	100%	Test Report	-	H	RW (Note 1)
4.3	Functional Test for Actuator Operated Valves	Satisfactory Performance	100%	Test Report	-	H	RW

Copyright EIL - All rights reserved

Format No 8-00-0001-F7 Rev 0

PROCUREMENT OF VALVES FOR CONFIDENTIAL DEMO PLANT AT MRPL,
MANGALURU, KARNATAKA

STANDARD SPECIFICATION NO.
6-81-0004 Rev. 6
Page 6 of 7

INSPECTION AND TEST PLAN
FOR
VALVES

SL NO	STAGE / ACTIVITY	CHARACTERISTICS	QUANTUM OF CHECK	RECORD	SCOPE OF INSPECTION		
					SUB SUPPLIER	SUPPLIER	EIL/TPIA
4.4	PMI Check	Chemical	As per EIL Spec. 6-81-0001	Inspection Report	-	H	RW
4.5	Strip Check (As applicable)	Verify Components & Differential hardness if applicable	As per PR / Purchase Specification	Inspection Report	-	H	RW (Note-1)
4.6	Final Stamping	Stamping of Accepted Valves	Stamping of Valves which are witnessed by EIL/TPIA.	Inspection Report	-	H	H (Note-1)
5.0	Painting						
5.1	Painting and Color coding as applicable	Visual / DFT Check	100%	Inspection Report	-	H	-
6.0	Documentation & IC						
6.1	Documentation & Inspection Certificate (IC)	Review of Stage Inspection Reports / Test Reports & Issue of IC	100%	Supplier TC & IC	-	H	H

Legend: H- Hold (Do not proceed without approval), P-Perform, RW - Random Witness (As specified or 10% (min.1 no. of each size and type of Bulk item)), R- Review, W-Witness (Give due notice, work may proceed after scheduled date).

NOTES (As applicable):

1. Non NACE & Non Hydrogen service Carbon Steel Cast Valves up to size 12"-300ANSI Class and Carbon Steel Forged Valves up to size 1.5"- 800 ANSI Class will be accepted on review of Supplier Test Certificates. Supplier Test Certificate along with back up reports to be reviewed by EIL/TPIA
2. This document describes the generic test requirements. Any additional test or Inspection scope if specified in contract documents shall also be applicable. (Unless otherwise agreed upon)
3. Acceptance Norms for all the activities shall be as per PO/PR/STANDARDS referred therein /Job Specification /Approved Documents.