	<b>MRPL Marketing Terminal Project at Devangonhi, Bangalore Marketing Infrastructure Projects, MRPL.</b>	
<b>LSTK-A PACKAGE : TANKAGE AND ASSOCIATED CIVIL, MECHANICAL, PIPING, ELECTRICAL, INSTRUMENTATION &amp; FIRE FIGHTING WORKS ADDENDUM 04</b>		

## ADDENDUM 04

To

### MRPL Tender No. 3200000495 dated 26.03.2021

**TENDER FOR: TANKAGE AND ASSOCIATED CIVIL, MECHANICAL, PIPING, ELECTRICAL, INSTRUMENTATION & FIRE FIGHTING WORKS  
(LSTK-A PACKAGE) MRPL MARKETING TERMINAL PROJECT  
AT DEVANGONTHI, BANGALORE MARKETING INFRASTRUCTURE PROJECTS, MRPL**

**With reference to the above tender and subsequent Addendum 1 Addendum 2 and Addendum 3 Bidders are requested to note the following:**



The items, conditions, specification and stipulations of the Bidding Documents are modified to the extent indicated as follows

- a. **Annexure 01 – Commercial Addendum.**
- b. **Annexure 02 – Technical Addendum.**
- c. **Annexure 03 – Technical Clarification.**

The implications of the same, elsewhere in the tender shall be taken care of appropriately by the bidders. All other terms and conditions, stipulations and specifications of tender shall remain unaltered.

**Note:**

Bidders shall upload the copy of these documents along with the technical- commercial bid, **Digitally Signed**, as a token of having read and understood the same.

 <b>ONGC</b> एम आर पी एल <b>MRPL</b>	<b>MRPL Marketing Terminal Project at Devangonhi, Bangalore</b> <b>Marketing Infrastructure Projects, MRPL.</b>	 <b>nauvata</b> ENGINEERING CONSULTANTS
	<b>LSTK-A PACKAGE : TANKAGE AND ASSOCIATED CIVIL, MECHANICAL,          PIPING, ELECTRICAL, INSTRUMENTATION &amp; FIRE FIGHTING WORKS</b> <b>ADDENDUM 04</b>	

**ANNEXURE 01 – COMMERCIAL ADDENDUM**

Sl. No.	Volume	Section No./Clause No.	Page No.	Existing Tender Clause	Addition / Deletion / Modification
1.	Volume_I Commercial _Section	Part I – Techno-Commercial Part NOTICE INVITING TENDER (NIT) 2.0 BRIEF SCOPE OF WORK OF LSTK- A PACKAGE CONTRACTOR	17 of 3638	The Scope of Work shall be on Lumpsum Turnkey (LSTK) basis involving but not limited to Design, Engineering, Procurement, Supply, Fabrication, Construction, Installation/Erection, Insulation, Calibration, Painting, Hook-up, Inspection, Testing, Mechanical completion, Pre-commissioning, Commissioning and Start-Up assistance, performance Guarantees, Hydraulic Guarantees, etc of Storage Tanks along with Civil, Piping, Mechanical, Electrical, Instrumentation, fire-fighting, other packages and miscellaneous jobs as detailed in the Bidding Document.	<b><u>Modification</u></b> The Scope of Work shall be on Lumpsum Turnkey (LSTK) basis involving but not limited to Design, detailed Engineering, Procurement, Supply, Inspection., Fabrication, Construction, Installation/Erection, Insulation, Calibration, Painting, Hook-up, Inspection, Testing, Mechanical completion, Pre-commissioning, Commissioning and Start-Up assistance, performance Guarantees, Hydraulic Guarantees, etc of Storage Tanks, <b>Pipeline from PMHB unit to PLT Exchange Manifold, and associated terminal facilities</b> along with related Civil, Piping, Mechanical, Electrical, Instrumentation, fire-fighting, all allied and associated works.
2.	Volume_I Commercial _Section	Part I – Techno-Commercial Part, INSTRUCTIONS TO BIDDERS (ITB) 1.0 GENERAL	40 of 3638	Every bidder must submit bid strictly in accordance with the conditions and specifications prescribed by PMC/OWNER. Special conditions (if any) submitted along with the bid documents by the bidder will not be applicable to this Tender, in case they are in conflict with any of our terms and conditions.	<b><u>Modification</u></b> Every bidder must submit bid strictly in accordance with the conditions and specifications prescribed by PMC/OWNER. <b>Bidders own terms and conditions</b> Or Special conditions (if any) submitted along with the bid documents by the bidder will not be acceptable to this Tender, in case they are in conflict with any of our terms and conditions.





**MRPL Marketing Terminal Project at Devangonhi, Bangalore  
Marketing Infrastructure Projects, MRPL.**

**LSTK-A PACKAGE : TANKAGE AND ASSOCIATED CIVIL, MECHANICAL,  
PIPING, ELECTRICAL, INSTRUMENTATION & FIRE FIGHTING WORKS**



**ADDENDUM 04**





Sl. No.	Volume	Section No./Clause No.	Page No.	Existing Tender Clause	Addition / Deletion / Modification
3.	Volume_I Commercial _Section	Part I – Techno-Commercial Part, 9.1 PROJECT EXECUTION PHILOSOPHY / 3 PROJECT IMPLEMENTATION / 3.1 Kick off Meeting	668 of 3638	Meeting shall be held with fifteen (15) calendar days after the CONTRACT AWARD. LSTK CONTRACTOR shall submit first issue of the procedures, which shall include: 1) Project Procedures 2) Project Organization Chart and Project Schedule 3) Engineering, Procurement, Construction and Commissioning Execution Plan. Refer to details under section "Project Planning, Scheduling and Monitoring procedure "in the TENDER PACKAGE.	<b><u>Modification</u></b> Meeting shall be held with fifteen (15) calendar days after the CONTRACT AWARD, which shall include: 1) Project Description 2) Project Organization Chart 3) Project Planning Package 4) Project Schedule 5) Communication Protocol 6) Engineering, Procurement, Construction, Installation and Commissioning including execution plan. 7)Project Procedures  LSTK CONTRACTOR shall submit first issue of the procedures at the time of Kick off meeting, Refer to details under section "Project Planning, Scheduling and Monitoring procedure "in the TENDER PACKAGE
4.	Volume_I Commercial _Section	Part I – Techno-Commercial Part, 9.1 PROJECT EXECUTION PHILOSOPHY / 4 ENGINEERING DESIGN/ 4.2 Engineering	670 of 3638	It is expected that LSTK CONTRACTOR shall be carrying out all engineering work in house. However, incase LSTK CONTRACTOR does not have in house resources for any specialized activity, the same may be carried out through third party agency. LSTK CONTRACTOR shall ensure that the agency is reputed and has adequate relevant experience. LSTK	<b><u>Modification</u></b> It is expected that LSTK CONTRACTOR shall be carrying out all engineering work in house. However, in case LSTK CONTRACTOR does not have in house resources for any specialized activity, the same may be carried out through third party agency. LSTK CONTRACTOR shall ensure that the agency is reputed and has adequate <b>&amp; proven</b> relevant experience. LSTK CONTRACTOR shall obtain prior



 एम आर पी एल MRPL	<b>MRPL Marketing Terminal Project at Devangonhi, Bangalore</b> <b>Marketing Infrastructure Projects, MRPL.</b>	 nauvata ENGINEERING PROJECTS & SERVICES
	<b>LSTK-A PACKAGE : TANKAGE AND ASSOCIATED CIVIL, MECHANICAL,          PIPING, ELECTRICAL, INSTRUMENTATION &amp; FIRE FIGHTING WORKS</b> <b>ADDENDUM 04</b>	

Sl. No.	Volume	Section No./Clause No.	Page No.	Existing Tender Clause	Addition / Deletion / Modification
				CONTRACTOR shall obtain prior approval from PMC/OWNER before engaging such agency. LSTK CONTRACTOR shall take full responsibility for the work carried out by the agency. LSTK CONTRACTOR shall submit the Document Control Index (DCI) for PMC review and annotation.	approval from MRPL/PMC before engaging such agency. <b>The decision of MRPL/PMC in this regard shall be final.</b> LSTK CONTRACTOR shall take full responsibility for the work carried out by the agency. LSTK CONTRACTOR shall submit the Document Control Index (DCI) for PMC review and annotation.
5.	Volume_I Commercial _Section	Part I – Techno-Commercial Part, 9.1 PROJECT EXECUTION PHILOSOPHY / 6 CONSTRUCTION / 6.1 General	670 of 3638	LSTK CONTRACTOR shall provide all labour, construction equipment, tools and tackles, materials, consumables, temporary facilities, construction utilities and so on, and support services for the construction work.	<b>Modification</b> LSTK CONTRACTOR shall provide all labour, <b>construction equipment and aids but not limited to cranes of adequate capacity, hydraulics, Fork - lifts</b> , tools and tackles, materials, consumables, temporary facilities, construction utilities and so on, and support services for the construction work. LSTK contractor shall hire a well-qualified agency for carrying out RT, UT, etc., during construction
6.	Volume_I Commercial _Section	Part I – Techno-Commercial Part, 9.1 PROJECT EXECUTION PHILOSOPHY / 6 CONSTRUCTION / 6.2 Temporary Facilities	671 of 3638	LSTK CONTRACTOR shall make his own arrangements for the supply of construction and potable water	<b>Modification</b> LSTK CONTRACTOR shall make his own arrangements for the supply of <b>construction water, water for hydro-test and potable water as per the quality specified in the tender.</b>



		<b>MRPL Marketing Terminal Project at Devangonhi, Bangalore</b> <b>Marketing Infrastructure Projects, MRPL.</b>				
<b>LSTK-A PACKAGE : TANKAGE AND ASSOCIATED CIVIL, MECHANICAL,          PIPING, ELECTRICAL, INSTRUMENTATION &amp; FIRE FIGHTING WORKS</b> <b>ADDENDUM 04</b>						
Sl. No.	Volume	Section No./Clause No.	Page No.	Existing Tender Clause	Addition / Deletion / Modification	
7.	Volume_I Commercial _Section	Part I – Techno-Commercial Part, 9.1 PROJECT EXECUTION PHILOSOPHY / 7 PRE-COMMISSIONING AND COMMISSIONING	671 of 3638	LSTK CONTRACTOR shall perform pre-commissioning and commissioning work for the facilities in accordance with requirements of the TENDER PACKAGE.	<b>Modification</b> LSTK CONTRACTOR shall perform pre-commissioning and commissioning work for the facilities including pipeline cleaning, chemical cleaning (if required), hydro test, drying etc in accordance with requirements of the TENDER PACKAGE.	
8.	Volume_I Commercial _Section	Part I – Techno-Commercial Part, 9.1 PROJECT EXECUTION PHILOSOPHY / 9 SAFETY	672 of 3638	SAFETY	<b>Modification</b> SAFETY shall be read as HSE.	
9.	Volume_I Commercial _Section	Part I – Techno-Commercial Part, 9.1 PROJECT EXECUTION PHILOSOPHY / 11 TRAINING	672 of 3638	LSTK CONTRACTOR shall provide training for OWNER's personnel both at SITE and outside India, including training at supplier's shops, and LSTK CONTRACTOR's offices.	<b>Modification</b> LSTK CONTRACTOR shall provide training for MRPL's personnel at SITE, training at supplier's/OEM shops, and LSTK CONTRACTOR's offices.	
10.	Volume_I Commercial _Section	Part I – Techno-Commercial Part, 9.1 PROJECT EXECUTION PHILOSOPHY / Annexure – 1/ Interface matrix	679 of 3638	‘Tank Farm contractor’	<b>Modification</b> ‘Tank Farm contractor’ shall be read as ‘LSTK contractor’ in this section	
11.	Volume_I Commercial _Section	Part I – Techno-Commercial Part, 9.1 PROJECT EXECUTION	681 of 3638	Design, supply, installation, testing and commissioning of firewater storage tanks, firewater pumps, jockey pumps, foam storage tanks,	<b>Modification</b> Design, supply, installation, testing ,pre-commissioning and commissioning of	

 <b>ONGC</b> एन आर पी एल <b>MRPL</b>	<b>MRPL Marketing Terminal Project at Devangonhi, Bangalore</b> <b>Marketing Infrastructure Projects, MRPL.</b>	 <b>nauvata</b> ENGINEERING PROJECTS & SERVICES
	<b>LSTK-A PACKAGE : TANKAGE AND ASSOCIATED CIVIL, MECHANICAL,          PIPING, ELECTRICAL, INSTRUMENTATION &amp; FIRE FIGHTING WORKS</b> <b>ADDENDUM 04</b>	



Sl. No.	Volume	Section No./Clause No.	Page No.	Existing Tender Clause	Addition / Deletion / Modification
		PHILOSOPHY / Annexure – 1/ Interface matrix/SR No 3		foam/firewater spray/sprinklers system, foam pumps, HVLR monitors package, fire hydrants, firewater/foam monitors, Remote Operated HVLR water-foam monitors, complete firewater/foam networks, associated piping, instruments and controls.	<b>complete Fire water and Foam system including</b> firewater storage tanks, firewater pumps, jockey pumps, foam storage tanks, foam/firewater spray/sprinklers system, foam pumps, HVLR monitors package, fire hydrants, firewater/foam monitors, Remote operated HVLR water- foam monitors, complete firewater/foam networks, associated piping, instruments and controls.
12.	Volume_I Commercial _Section	Part I – Techno- Commercial Part, SPECIAL CONDITIONS OF CONTRACT (SCC) 21.0 HEALTH, SAFETY AND ENVIRONMENT (HSE) MANAGEMENT	490 of 3638	NEW ADDITION	<u><b>Addition</b></u> <ul style="list-style-type: none"> <li>• The CONTRACTOR will be responsible for Health, Safety and Environment (HSE) Management at construction site for the construction activities to be carried out by the CONTRACTOR/their approved SUBCONTRACTORS.</li> <li>• CONTRACTOR shall have a documented HSE policy to cover commitment of their organization to ensure Health, Safety and Environment aspects in their line operation.</li> <li>• It is the responsibility of the CONTRACTOR to ensure that safe construction procedures are complied with.</li> <li>• CONTRACTOR to ensure that following safety measures are compiled:</li> </ul>

 <b>ONGC</b> एन आर पी एल <b>MRPL</b>	<b>MRPL Marketing Terminal Project at Devangonhi, Bangalore</b> <b>Marketing Infrastructure Projects, MRPL.</b>	 <b>nauvata</b> <small>ENGINEERING PROJECTS &amp; SERVICES</small>
	<b>LSTK-A PACKAGE : TANKAGE AND ASSOCIATED CIVIL, MECHANICAL,          PIPING, ELECTRICAL, INSTRUMENTATION &amp; FIRE FIGHTING WORKS</b> <b>ADDENDUM 04</b>	

Sl. No.	Volume	Section No./Clause No.	Page No.	Existing Tender Clause	Addition / Deletion / Modification
					<ul style="list-style-type: none"> <li>➤ The use of safety gadgets, viz. safety goggles, helmets, safety shoes, safety belts, provision of safety net for construction at higher elevations and provision of toe boards in scaffolding platforms, etc.</li> <li>➤ All hot works must be performed by ensuring compliance to the requirements as specified by MRPL from time to time.</li> <li>➤ Barricading of crane movement areas / Radiography areas</li> <li>➤ Proper earthing of equipment.</li> <li>➤ Proper shoring / strutting of Excavated Areas.</li> <li>➤ Cylinders of inflammable gases to be stacked upright</li> <li>• To assist in the development of an effective safety program, a safety check list for various jobs shall be developed by the CONTRACTOR and the same shall be adhered to by the CONTRACTOR's RCM / Site-In-charge. The responsibilities of the CONTRACTOR will include but not limited to::</li> </ul>



		<b>MRPL Marketing Terminal Project at Devangonhi, Bangalore Marketing Infrastructure Projects, MRPL.</b>			
		<b>LSTK-A PACKAGE : TANKAGE AND ASSOCIATED CIVIL, MECHANICAL, PIPING, ELECTRICAL, INSTRUMENTATION &amp; FIRE FIGHTING WORKS</b>			
		<b>ADDENDUM 04</b>			
Sl. No.	Volume	Section No./Clause No.	Page No.	Existing Tender Clause	Addition / Deletion / Modification
					<ul style="list-style-type: none"> <li>➤ Coordination and supervision of the details of the job safety program</li> <li>➤ Initiation of accident reporting, investigation and follow-up actions. Preparation of periodic accident summaries.</li> <li>➤ Periodic Accident Analysis Reports</li> <li>➤ Periodic HSE Audits</li> <li>➤ Tallying safety inspection of the job and submission of summary inspection report to PMC/OWNER.</li> <li>➤ Obtaining work permits for Hot/Cold Jobs from the MRPL.</li> <li>➤ Check the fitness of cranes and other hoisting equipment on periodic basis/before all major lifts and submit to PMC/OWNER valid/latest test certificates of tackles used for lifting</li> <li>➤ Submission of any other report required by MRPL/ PMC.</li> </ul>



	<b>MRPL Marketing Terminal Project at Devangonhi, Bangalore</b> <b>Marketing Infrastructure Projects, MRPL.</b>	
	<b>LSTK-A PACKAGE : TANKAGE AND ASSOCIATED CIVIL, MECHANICAL,          PIPING, ELECTRICAL, INSTRUMENTATION &amp; FIRE FIGHTING WORKS</b> <b>ADDENDUM 04</b>	

**ANNEXURE 02 – TECHNICAL ADDENDUM**

Sl. No.	Volume	Section No./Clause No.	Page No.	Existing Tender Clause	Addition / Deletion / Modification
1.	Volume_II_Technical_Section_Part_1	Part II – Technical Part, PACKAGE SCOPE OF WORK / 19. SCOPE OF WORK FOR FEED PIPELINE (FROM PMHBL MANIFOLD TO MRPL PLT MANIFOLD)	1417 to 1435 OF 3638	-	<b><u>Modification.</u></b>  The referred page numbers are replaced with attached page from Sheet 36 to 56 of Addendum 4.
2.	Volume II, Technical Section Part 30	D.34	3263 of 3638	20005-GEN-L-DW-3001 Rev 1	Replaced with Rev 2 <b>20005-GEN-L-DW-3001 Rev 3</b>
3.	Volume II, Technical Section Part 30	D.38	3267 of 3638	20005-GEN-P-PID-1005 Rev 1.	Replaced with Rev. 1 <b>20005-GEN-P-PID-1005 Rev 2.</b>
4.	Volume II, Technical Section Part 30	D.61	3290 of 3638	20005-GEN-P-PID-1016 Rev 1.	Replaced with Rev. 1 <b>20005-GEN-P-PID-1016 Rev 2.</b>
5.	-	-	-	-	<b>Addition</b> “20005-GEN-I-SP-6017: Specification for DBBV Rev. 0” issued.
6.	Addendum 02/ Annexure 02/	D.35	178 of 181	20005-GEN-PL-SK-0001 Rev 1	Replaced with Rev 2 <b>20005-GEN-PL-SK-0001 Rev 2</b>
7.	Volume II, Technical	-	-	-	<b>Addition</b>

	<b>MRPL Marketing Terminal Project at Devangonhi, Bangalore</b> <b>Marketing Infrastructure Projects, MRPL.</b>	
	<b>LSTK-A PACKAGE : TANKAGE AND ASSOCIATED CIVIL, MECHANICAL,          PIPING, ELECTRICAL, INSTRUMENTATION &amp; FIRE FIGHTING WORKS</b> <b>ADDENDUM 04</b>	

Sl. No.	Volume	Section No./Clause No.	Page No.	Existing Tender Clause	Addition / Deletion / Modification
	Section Part 30				<b>“20005-GEN-PL-SK-0001, SCHEMATIC OF MRPL WORKS IN PMHBL MANIFOLD AREA, SHEET 1 OF 2. Rev 0.</b>
8.	Volume II, Technical Section Part 28	C.3.41	3145-3148	20005-GEN-M-DS-4026 Rev 0.	Replaced with Rev. 1 <b>20005-GEN-M-DS-4026 Rev 1</b>
9.	Volume II, Technical Section Part 28	C.3.42	3149-3152	20005-GEN-M-DS-4027 Rev 0.	Replaced with Rev. 1 <b>20005-GEN-M-DS-4027 Rev 1.</b>
10.	Volume II, Technical Section Part 28	C.3.43	3153-3156	20005-GEN-M-DS-4028 Rev 0.	Replaced with Rev. 1 <b>20005-GEN-M-DS-4028 Rev 1.</b>
11.	Volume II, Technical Section Part 28	C.3.44	3157-3160	20005-GEN-M-DS-4029 Rev 0.	Replaced with Rev. 1 <b>20005-GEN-M-DS-4029 Rev 1.</b>
12.	Volume II, Technical Section Part 28	C.3.45	3161-3164 of 3638	20005-GEN-M-DS-4030 Rev 0.	Replaced with Rev. 1 <b>20005-GEN-M-DS-4030 Rev 1.</b>
13.	Volume II, Technical Section Part 28	C.3.24	3019-3021 of 3638	20005-GEN-PL-DS-7013 Rev 0.	Replaced with Rev. 1 <b>20005-GEN-PL-DS-7013 Rev 1.</b>
14.	Volume II, Technical	D.23	3252 of 3638	20005-GEN-M-DW-4100 Rev 0.	Replaced with Rev. 1 <b>20005-GEN-M-DW-4100 Rev 1.</b>





**MRPL Marketing Terminal Project at Devangonhi, Bangalore  
Marketing Infrastructure Projects, MRPL.**

**LSTK-A PACKAGE : TANKAGE AND ASSOCIATED CIVIL, MECHANICAL,  
PIPING, ELECTRICAL, INSTRUMENTATION & FIRE FIGHTING WORKS**



**ADDENDUM 04**





Sl. No.	Volume	Section No./Clause No.	Page No.	Existing Tender Clause	Addition / Deletion / Modification
	Section Part 30				
15.	Volume II, Technical Section Part 30	D.24	3253 of 3638	20005-GEN-M-DW-4101 Rev 0.	Replaced with Rev. 1 <b>20005-GEN-M-DW-4101 Rev 1.</b>
16.	Volume II, Technical Section Part 30	D.25	3254 of 3638	20005-GEN-M-DW-4102 Rev 0.	Replaced with Rev. 1 <b>20005-GEN-M-DW-4102 Rev 1.</b>
17.	Volume II, Technical Section Part 30	D.26	3255 of 3638	20005-GEN-M-DW-4103 Rev 0.	Replaced with Rev. 1 <b>20005-GEN-M-DW-4103 Rev 1.</b>
18.	Volume II, Technical Section Part 30	D.27	3256 of 3638	20005-GEN-M-DW-4104 Rev 0.	Replaced with Rev. 1 <b>20005-GEN-M-DW-4104 Rev 1.</b>
19.	Volume II, Technical Section Part 30	D.28	3257 of 3638	20005-GEN-M-DW-4105 Rev 0.	Replaced with Rev. 1 <b>20005-GEN-M-DW-4105 Rev 1.</b>
20.	Volume II, Technical Section Part 30	D.29	3258 of 3638	20005-GEN-M-DW-4106 Rev 0.	Replaced with Rev. 1 <b>20005-GEN-M-DW-4106 Rev 1.</b>
21.	Volume II, Technical Section Part 30	D.30	3259 of 3638	20005-GEN-M-DW-4107 Rev 0.	Replaced with Rev. 1 <b>20005-GEN-M-DW-4107 Rev 1.</b>



 <b>ONGC</b> एन ओर पी एल <b>MRPL</b>	<b>MRPL Marketing Terminal Project at Devangonhi, Bangalore</b> <b>Marketing Infrastructure Projects, MRPL.</b>	 <b>nauvata</b> ENGINEERING CONSULTANTS
	<b>LSTK-A PACKAGE : TANKAGE AND ASSOCIATED CIVIL, MECHANICAL,          PIPING, ELECTRICAL, INSTRUMENTATION &amp; FIRE FIGHTING WORKS</b> <b>ADDENDUM 04</b>	

Sl. No.	Volume	Section No./Clause No.	Page No.	Existing Tender Clause	Addition / Deletion / Modification
22.	Volume II, Technical Section Part 27	C.3.10	2777-2819 of 3638	20005-GEN-M-SPE-4005 Rev 0	Replaced with Rev 1. <b>20005-GEN-M-SPE-4005 Rev 1</b>
23.	Volume_II_Technical_Section_Part_31	E.1.4	3395-3406 of 3638	20005-GEN-E-SPE-5011 Rev 0	Replaced with Rev 1. <b>20005- GEN-E-SPE-5011 Rev 1</b>
24.	-	-	-	-	<u>Addition.</u> <b>“20005-GEN-E-SPE-5003 – STANDARD SPECIFICATION FOR OIL FILLED DISTRIBUTION TRANSFORMER”.</b>
25.	-	-	-	-	<u>Addition</u> <b>“20005-GEN-E-SPE-5020 - STANDARD SPECIFICATION FOR IMPRESSED CURRENT CATHODOIC PROTECTION SYSTEM FOR PIPELINES”.</b>
26.	Volume_II_Technical_Section_Part_1	Part A/ Section A-2	994-1042 of 3638	20005-GEN-G-DOC-9105 Rev 0	Replaced with Rev 1. <b>20005-GEN-G-DOC-9105 Rev 1</b>
27.	Volume_II_Technical_Section_Part_1	Part II – Technical Part, CONSTRUCTION SUPERVISION AND MANAGEMENT / 1 GENERAL CONTROL AND ADMINISTRATION / 1.1 SCOPE OF		NEW ADDITION	<u>Addition</u> CONTRACTOR shall plan, execute, manage and control all the construction activities for the Facilities complying fully to the applicable codes and standards, applicable laws and regulations, conditions of labour, local conditions, the SITE conditions, environmental aspects and shall comply with the requirements thereof as part of this Contract.



 <b>ONGC</b> एन आर पी एल <b>MRPL</b>	<b>MRPL Marketing Terminal Project at Devangonhi, Bangalore</b> <b>Marketing Infrastructure Projects, MRPL.</b>	 <b>nauvata</b> ENGINEERING CONSULTANTS
	<b>LSTK-A PACKAGE : TANKAGE AND ASSOCIATED CIVIL, MECHANICAL,          PIPING, ELECTRICAL, INSTRUMENTATION &amp; FIRE FIGHTING WORKS</b> <b>ADDENDUM 04</b>	

Sl. No.	Volume	Section No./Clause No.	Page No.	Existing Tender Clause	Addition / Deletion / Modification
		CONSTRUCTION WORK			As part of construction scope, all frontline construction supervision is to be provided by CONTRACTOR and this cannot be construed to be part of MRPL/ PMC.
28.	Volume_II_Technical_Section_Part_1	Part II – Technical Part, CONSTRUCTION SUPERVISION AND MANAGEMENT / 1 GENERAL CONTROL AND ADMINISTRATION / 1.2 CONSTRUCTION EXECUTION PLAN (CEP)	885 of 3638	NEW ADDITION	<p><b>Addition</b>            CONTRACTOR’S overall manpower and man-hour histogram, discipline wise manpower deployment schedule on monthly basis with distribution of Local Personnel.</p> <p>CEP shall also include Major equipment mobilization plan on monthly basis with short description.            CONTRACTOR to develop this plan with due consideration to maximize the mechanization of construction activities.</p> <p>• Other plans of CONTRACTOR and procedures to be submitted at least four (4) weeks prior to start of respective activity at site, which shall include the following as a minimum</p> <ul style="list-style-type: none"> <li>• Temporary facilities, etc.</li> <li>• Scaffolding plan</li> <li>• Heavy / ODC transport and heavy lifting plan (Rigging Plan)</li> <li>• Pre-fabrication plan</li> <li>• Hydro-test plan</li> <li>• Other activity plans e.g. piping, equipment and steel structure erection plan etc.</li> <li>• Instrument loop check plan</li> <li>• Monsoon counter measures and preparation</li> <li>• Emergency Evacuation Procedure</li> <li>• Storm Management Plan</li> </ul>

		<b>MRPL Marketing Terminal Project at Devangonhi, Bangalore</b> <b>Marketing Infrastructure Projects, MRPL.</b>				
<b>LSTK-A PACKAGE : TANKAGE AND ASSOCIATED CIVIL, MECHANICAL,          PIPING, ELECTRICAL, INSTRUMENTATION &amp; FIRE FIGHTING WORKS</b> <b>ADDENDUM 04</b>						
Sl. No.	Volume	Section No./Clause No.	Page No.	Existing Tender Clause	Addition / Deletion / Modification	
					<ul style="list-style-type: none"> <li>• Deployment schedule of Construction equipment, Tools &amp; Tackle proposed for execution of Work</li> <li>• Deployment schedule of Construction Manpower (Staff &amp; Worker)</li> <li>• Detailed Construction Schedule</li> <li>• Site Organization Plan</li> <li>• Detailed Execution Philosophy</li> <li>• Field Quality assurance &amp; control procedure</li> <li>• Subcontracting Plan</li> </ul>	
29.	Volume_II_Technical_Section_Part_1	Part II – Technical Part, CONSTRUCTION SUPERVISION AND MANAGEMENT / 4 CONSTRUCTION CONTRACTS/ 4.1 SUBCONTRACTS	891 of 3638	NEW ADDITION	<p><b>Addition</b>            If CONTRACTOR proposes to engage SUBCONTRACTOR(s) for the execution of some activities at site, the credentials of proposed SUBCONTRACTOR(s) will be submitted by the CONTRACTOR to PMC and copied to MRPL, on award of work which will be evaluated by PMC for acceptance before the award of the work to the sub-contractor. CONTRACTOR shall not be permitted to change the SUBCONTRACTOR during the execution of such works without prior approval of PMC.</p>	
30.	Volume_II_Technical_Section_Part_1	Part II – Technical Part, CONSTRUCTION SUPERVISION AND MANAGEMENT / 4 CONSTRUCTION CONTRACTS/ 4.1 SUBCONTRACTS	891 of 3638	NEW ADDITION	<p><b>Addition</b>            CONTRACTOR's Construction Execution Plan shall include the following :</p> <ul style="list-style-type: none"> <li>• SUBCONTRACT philosophy and plan</li> <li>• List and scope of work of each subcontract</li> <li>• Subcontract administration plan</li> </ul> Organization chart of each SUBCONTRACTOR. The list and major scope of each subcontract shall not be changed	



 <b>ONGC</b> एन आर पी एल <b>MRPL</b>	<b>MRPL Marketing Terminal Project at Devangonhi, Bangalore</b> <b>Marketing Infrastructure Projects, MRPL.</b>	 <b>nauvata</b> ENGINEERING PROJECTS & SERVICES
	<b>LSTK-A PACKAGE : TANKAGE AND ASSOCIATED CIVIL, MECHANICAL,          PIPING, ELECTRICAL, INSTRUMENTATION &amp; FIRE FIGHTING WORKS</b> <b>ADDENDUM 04</b>	

Sl. No.	Volume	Section No./Clause No.	Page No.	Existing Tender Clause	Addition / Deletion / Modification
					from those of the CONTRACTOR'S plan unless specially approved by MRPL.
31.	Volume_II_Technical_Section_Part_1	Part II – Technical Part, CONSTRUCTION SUPERVISION AND MANAGEMENT / 5 MATERIALS MANAGEMENT	891 of 3638	NEW ADDITION	<p><b><u>Addition</u></b>  <b>WAREHOUSE MANAGEMENT &amp; MATERIAL CONTROL</b>          The CONTRACTOR will be responsible for carrying out the Warehouse Management and Material Control in accordance with the approved warehousing procedure and material control procedure, which is to be submitted by the CONTRACTOR within one month of kick-off meeting. The activities shall include but not limited to:</p> <ul style="list-style-type: none"> <li>• Transport Liaison, both for imported materials as well as materials procured in India, from the time of dispatch up to receipt at site.</li> <li>• Transportation Plan (a) from source to site (b) site to erection location.</li> <li>• Receipt, Handling, Identification, Inspection (including confirmation by an PMI Analyser for Alloy Steel, Stainless Steel and other Exotic Materials) and Acceptance, Storage and Preservation of Materials, Codification of all materials including free issue materials (If any).</li> <li>• Filing of insurance Claims and follow up. Documentation for control and accounting of materials.</li> <li>• Generation and upkeep of Traceability Records for materials.</li> <li>• Materials Control &amp; Issue. Inventory Checks.</li> </ul>



 <b>ONGC</b> एन आर पी एल <b>MRPL</b>	<b>MRPL Marketing Terminal Project at Devangonhi, Bangalore</b> <b>Marketing Infrastructure Projects, MRPL.</b>	 <b>nauvata</b> ENGINEERING PROJECTS & SERVICES
	<b>LSTK-A PACKAGE : TANKAGE AND ASSOCIATED CIVIL, MECHANICAL,          PIPING, ELECTRICAL, INSTRUMENTATION &amp; FIRE FIGHTING WORKS</b> <b>ADDENDUM 04</b>	

Sl. No.	Volume	Section No./Clause No.	Page No.	Existing Tender Clause	Addition / Deletion / Modification
					<ul style="list-style-type: none"> <li>• Field Requisition and Purchase.</li> <li>• Supply and handing over of mandatory Spares and tools and tackles to the MRPL as per the terms of the contract.</li> <li>• Material Appropriation and Handing Over of all items along with material test certificates to MRPL as per the terms of contract</li> <li>• Security of Material</li> <li>• Coordination with suppliers on short supplied items and placing replacement orders for lost/damaged items</li> <li>• Intimating to CONTRACTOR's HO regarding short/lost/damaged items received at site and further replacement actions to make good on noticed items.</li> </ul>
32.	Volume_II_Technical_Section_Part_1	Part II – Technical Part, CONSTRUCTION SUPERVISION AND MANAGEMENT / 7 SITE FACILITIES AND LOGISTICS / 7.1.1 SECURITY	899 of 3638	Temporary and permanent access points which service the new construction area.	<u><b>Modification</b></u> Temporary and permanent access points which service the new construction area <b>shall be taken care by the client. However, all other securities regarding their site office, storage, all materials, tools, tackles etc. shall be the responsibility of LSTK contractor.</b>
33.	Volume_II_Technical_Section_Part_1	Part II – Technical Part, CONSTRUCTION SUPERVISION AND MANAGEMENT / 8 FIELD EXECUTION/ 8.9 SITE INSPECTION	912 of 3638	Contractor shall provide all the necessary testing and calibration equipment, including an appropriate instrument test workshop at the Site. Contractor shall	<u><b>Modification</b></u> Contractor shall provide all the necessary testing and calibration equipment, including an appropriate instrument test workshop at the Site. Contractor shall retain all records of calibration testing, including origin of the calibration. <b>The records shall also be maintained for</b>





	<b>MRPL Marketing Terminal Project at Devangonhi, Bangalore</b> <b>Marketing Infrastructure Projects, MRPL.</b>	
	<b>LSTK-A PACKAGE : TANKAGE AND ASSOCIATED CIVIL, MECHANICAL,          PIPING, ELECTRICAL, INSTRUMENTATION &amp; FIRE FIGHTING WORKS</b> <b>ADDENDUM 04</b>	



Sl. No.	Volume	Section No./Clause No.	Page No.	Existing Tender Clause	Addition / Deletion / Modification
		OF INSTRUMENT EQUIPMENT		retain all records of calibration testing, including origin of the calibration.	<b>the validity of calibration certificate for each testing/measuring instruments.</b>
34.	Volume_II_Technical_Section_Part_1	Part II – Technical Part, CONSTRUCTION QUALITY MANAGEMENT AND QUALITY CONTROL	918 of 3638	NEW ADDITION	<p><b>Addition</b></p> <p>The CONTRACTOR will be responsible for ensuring quality of construction carried out by the CONTRACTOR/ their approved SUBCONTRACTORS in accordance with the approved QA/QC procedures and management of material testing laboratory.</p> <ul style="list-style-type: none"> <li>• CONTRACTOR will carry out Inspection, Non-destructive Tests and analyze and certify acceptability of all welds, materials and works in accordance with specified technical standards/International standards and carryout inspection and testing of incoming materials as per approved ITP and all relevant procedures.</li> <li>• CONTRACTOR is required to prepare and submit documents as evidence of the tests performed and quality of works to PMC/OWNER as per the contract.</li> <li>• All Inspections and QA/QC Test Records are to be kept up to date including approved status from PMC / MRPL and in first rate condition by the CONTRACTOR and shall be made available to PMC/OWNER whenever requested. These documents shall be handed over to MRPL by the CONTRACTOR on completion of the Commissioning.</li> <li>• All work/services to be performed by the CONTRACTOR under this contract shall be of specified / approved quality and the CONTRACTOR shall have a QUALITY ASSURANCE/QUALITY CONTROL</li> </ul>

 <b>ONGC</b> एन आर पी एल <b>MRPL</b>	<b>MRPL Marketing Terminal Project at Devangonhi, Bangalore</b> <b>Marketing Infrastructure Projects, MRPL.</b>	 <b>nauvata</b> ENGINEERING PROJECTS & SERVICES
	<b>LSTK-A PACKAGE : TANKAGE AND ASSOCIATED CIVIL, MECHANICAL,          PIPING, ELECTRICAL, INSTRUMENTATION &amp; FIRE FIGHTING WORKS</b> <b>ADDENDUM 04</b>	

Sl. No.	Volume	Section No./Clause No.	Page No.	Existing Tender Clause	Addition / Deletion / Modification
					(QA/QC) system during the performance of various activities at Construction Site. • Review/approval of the activities by PMC / MRPL shall not dilute the responsibility of the CONTRACTOR for maintaining quality.
35.	Volume_II_Technical_Section_Part_1	Part II – Technical Part, CONSTRUCTION QUALITY MANAGEMENT AND QUALITY CONTROL / 6.5 USE / 6.5.1	921 of 3638	The material shall be stacked in such a way that the lot, which is procured, first will be consumed first. No material beyond its expiry date shall be used. If any material expiry date has elapsed or its properties have changed, it shall be removed from site or wherever there is any doubt, with the consent of PMC/OWNER it shall be sent to a reputed approved laboratory for testing and acceptance.	<b>Modification</b> The material shall be stacked in such a way that the lot, which is procured, first will be consumed first. No material beyond its expiry date/shelf life shall be used. If any material expiry date/shelf life has elapsed or its properties have changed, it shall be removed from site or wherever there is any doubt, with the consent of PMC/OWNER it shall be sent to a reputed approved laboratory for testing and acceptance. If Test results are found unsatisfactory, then the LSTK Contractor shall replace all such materials in an expedited manner to meet project completion performance including new approved stacking methodology of newly supplied items to maintain required shelf life.
36.	Volume_II_Technical_Section_Part_1	Part II – Technical Part, CONSTRUCTION QUALITY MANAGEMENT AND QUALITY CONTROL / 3 RESPONSIBILITY	919 of 3638	NEW ADDITION	<b>Addition</b> ITP covered in this document indicate the minimum requirements of testing and inspection. If any other inspection test requirement is found necessary during the execution of works, it shall be the LSTK contractor's responsibility to implement the same without any

	<b>MRPL Marketing Terminal Project at Devangonhi, Bangalore</b> <b>Marketing Infrastructure Projects, MRPL.</b>	
	<b>LSTK-A PACKAGE : TANKAGE AND ASSOCIATED CIVIL, MECHANICAL,          PIPING, ELECTRICAL, INSTRUMENTATION &amp; FIRE FIGHTING WORKS</b> <b>ADDENDUM 04</b>	

Sl. No.	Volume	Section No./Clause No.	Page No.	Existing Tender Clause	Addition / Deletion / Modification
					implication. The decision of PMC/OWNER in this regards shall be final.
37.	Volume_II_Technical_Section_Part_1	Part II – Technical Part, CONSTRUCTION QUALITY MANAGEMENT AND QUALITY CONTROL / 5 PROCUREMENT OF MATERIALS REQUIRED FOR EXECUTION OF WORKS	919 of 3638	The vendor list shall be in line with the contract document. In case vendor list is not available in the contract for a particular item, the CONTRACTOR can propose list of vendors.	<b><u>Modification</u></b> The vendor list shall be in line with the contract document. In case vendor list is not available in the contract for a particular item, the CONTRACTOR can propose list of vendors along with a meeting for newly proposed vendors. <b>Decision of MRPL/PMC (Engineer-in-charge) shall be final.</b>
38.	Volume_II_Technical_Section_Part_1	Part II – Technical Part, CONSTRUCTION QUALITY MANAGEMENT AND QUALITY CONTROL / 6 EXECUTION OF WORKS / 6.1	920 of 3638	Any deviation to the specification shall be brought to the notice of PMC/OWNER in proper formats by CONTRACTOR for approval.	<b><u>Modification</u></b> Any deviation to the specification shall be brought to the notice of PMC/OWNER in proper formats by CONTRACTOR for approval. <b>Decision of PMC/OWNER shall be final.</b>
39.	Volume_II_Technical_Section_Part_1	Part II – Technical Part, CONSTRUCTION QUALITY	920 of 3638	In case for the bought out items where approved vendors are	<b><u>Modification</u></b> In case for the bought out items where approved vendors are not given and which are readily available in market, reputed vendors/brand/product shall be identified by

 <b>ONGC</b> एन आर पी एल <b>MRPL</b>	<b>MRPL Marketing Terminal Project at Devangonhi, Bangalore</b> <b>Marketing Infrastructure Projects, MRPL.</b>	 <b>nauvata</b> ENGINEERING CONSULTANTS
	<b>LSTK-A PACKAGE : TANKAGE AND ASSOCIATED CIVIL, MECHANICAL,          PIPING, ELECTRICAL, INSTRUMENTATION &amp; FIRE FIGHTING WORKS</b> <b>ADDENDUM 04</b>	

Sl. No.	Volume	Section No./Clause No.	Page No.	Existing Tender Clause	Addition / Deletion / Modification
		MANAGEMENT AND QUALITY CONTROL / 6 EXECUTION OF WORKS / 6.3 SOURCE SELECTION /VENDOR APPROVAL / 6.3.2		not given and which are readily available in market, reputed vendors/brand/product shall be identified by CONTRACTOR and approval for the same shall be taken before hand from PMC/OWNER. Wherever the case demands samples of manufacturer's products shall also be produced for inspection and approval by PMC/OWNER.	CONTRACTOR and approval for the same shall be taken before hand from PMC/OWNER. Wherever the case demands samples of manufacturer's products shall also be produced for inspection and approval by PMC/OWNER. <b>Decision of PMC/OWNER shall be final.</b>
40.	Volume_II_Technical_Section_Part_1	Part II – Technical Part, CONSTRUCTION QUALITY MANAGEMENT AND QUALITY CONTROL / 6 EXECUTION OF WORKS / 6.6 INSPECTION/ 6.6.7	922 of 3638	All the bought out items, which are accompanied with manufacturer's test certificate (MTC), PMC/OWNER shall check at any time for the co-relation of lot/ heat/ Identification No. as shown in the MTC and as marked over the materials.	<b><u>Modification</u></b>  All the bought-out items ( <b>as necessary</b> ), shall be <b>procured along with their material test certificates (MTC)</b> . PMC/OWNER shall check at any time for the co-relation of lot/ heat/ Identification No. as shown in the MTC and as marked over the materials





**MRPL Marketing Terminal Project at Devangonhi, Bangalore  
Marketing Infrastructure Projects, MRPL.**



**LSTK-A PACKAGE : TANKAGE AND ASSOCIATED CIVIL, MECHANICAL,  
PIPING, ELECTRICAL, INSTRUMENTATION & FIRE FIGHTING WORKS  
ADDENDUM 04**





Sl. No.	Volume	Section No./Clause No.	Page No.	Existing Tender Clause	Addition / Deletion / Modification
41.	Volume_II_Technical_Section_Part_1	Part II – Technical Part, CONSTRUCTION QUALITY MANAGEMENT AND QUALITY CONTROL / 9. GENERAL NOTE AND LEGEND 9.2 LEGEND	922 of 3638	Prime responsibility for execution of the inspection is with the CONTRACTOR. (PMC/OWNER only)	<b><u>Modification</u></b>  Prime responsibility for execution of the inspection is with the CONTRACTOR.
42.	Volume_II_Technical_Section_Part_1	Part II – Technical Part, DOCUMENTS/ DRAWINGS FOR OWNER’S/ PMC’S REVIEW / 3.3. INSTRUCTION TO CONTRACTOR/ 3.3.15	1071 of 3638	Sequence of submission of drawings is essential for proper review of documents and timely completion of the project and the same is to be adhered to. In case sequence is not maintained, the documents submitted shall not be approved / reviewed by Owner / PMC and the responsibility of timely execution of the plant shall remain to Contractor’s accounts.	<b><u>Modification</u></b>  Sequence of submission of drawings is essential for proper review of documents and timely completion of the project and the same is to be adhered to. In case sequence is not maintained, <b>the documents approval/reviewed by Owner / PMC</b> may get delayed and the responsibility of timely execution of the plant shall remain to Contractor’s accounts.
43.	Volume_II_Technical_Section_Part_1	Part II – Technical Part, DOCUMENTS/ DRAWINGS FOR OWNER’S/ PMC’S REVIEW / 3.3.	1072 of 3638	Documents required to be submitted by Contractor to Statutory Regulation Authorities indicated in	<b><u>Modification</u></b>  Documents required to be submitted by Contractor to

	<b>MRPL Marketing Terminal Project at Devangonhi, Bangalore</b> <b>Marketing Infrastructure Projects, MRPL.</b>	
	<b>LSTK-A PACKAGE : TANKAGE AND ASSOCIATED CIVIL, MECHANICAL,          PIPING, ELECTRICAL, INSTRUMENTATION &amp; FIRE FIGHTING WORKS</b> <b>ADDENDUM 04</b>	



Sl. No.	Volume	Section No./Clause No.	Page No.	Existing Tender Clause	Addition / Deletion / Modification
		INSTRUCTION TO CONTRACTOR/ 3.3.20		PREAMBLE shall have to be furnished beforehand to Owner / PMC.	Statutory Regulation Authorities like <b>PESO</b> shall have to be furnished beforehand to Owner / PMC
44.	Volume_II_Technical_Section_Part_1	Part II – Technical Part, DOCUMENTS/ DRAWINGS FOR OWNER’S/ PMC’S REVIEW / 3.3. INSTRUCTION TO CONTRACTOR/ 3.3.31	1073 of 3638	Only HTRI latest software’s to be used for thermal design of shell and tube heat exchangers and air-cooled exchangers. Design output shall be made available on CDs in HTRI versions	<u><b>Modification</b></u> Only HTRI latest software to be used for thermal design of shell and tube heat exchangers and air-cooled exchangers. Design output shall be made available on <b>any removable media like Pen-drive etc., in HTRI versions.</b>
45.	Volume_II_Technical_Section_Part_1	Part II – Technical Part, DOCUMENTS/ DRAWINGS FOR OWNER’S/ PMC’S REVIEW / 3.3. INSTRUCTION TO CONTRACTOR/ 3.4.2	1073 of 3638	Contractor shall submit a comprehensive bid evaluation report and recommendation for procurement of major equipment to Owner / PMC prior to award of purchase order. The report shall incorporate, but is not limited to; Names and addresses of the companies invited to quote or bid. Recommended supplier Evaluation of Vendor quality system Scheduled award date	<u><b>Modification</b></u> Contractor shall submit a comprehensive bid evaluation report and recommendation for procurement of major equipment to Owner / PMC prior to award of purchase order. The report shall incorporate, but is not limited to; <ol style="list-style-type: none"> <li>a) Names and addresses of the companies invited to quote or bid.</li> <li>b) Compliance to technical and commercial requirements specified in the bid.</li> <li>c) Reason for acceptance of any deviation taken by any bidder.</li> <li>d) Recommended supplier</li> <li>e) Evaluation of Vendor quality system</li> <li>f) Scheduled award date</li> <li>g) Quoted delivery date</li> </ol>

 <b>ONGC</b> एन आर पी एल <b>MRPL</b>	<b>MRPL Marketing Terminal Project at Devangonhi, Bangalore</b> <b>Marketing Infrastructure Projects, MRPL.</b>	 <b>nauvata</b> ENGINEERING CONSULTANTS
	<b>LSTK-A PACKAGE : TANKAGE AND ASSOCIATED CIVIL, MECHANICAL,          PIPING, ELECTRICAL, INSTRUMENTATION &amp; FIRE FIGHTING WORKS</b> <b>ADDENDUM 04</b>	

Sl. No.	Volume	Section No./Clause No.	Page No.	Existing Tender Clause	Addition / Deletion / Modification
				Quoted delivery date Reason(s) for rejecting unsuccessful bidders whether it is technical, commercial, delivery etc. Reason for recommendation.	h) Reason(s) for rejecting unsuccessful bidders whether it is technical, commercial, delivery etc. i) Reason for recommendation.
46.	Volume_II_Technical_Section_Part_1	Part II – Technical Part, DOCUMENTS/ DRAWINGS FOR OWNER’S/ PMC’S REVIEW / 4. Documents / Drawings for Approval, Review by Owner / PMC 4.1. DOCUMENTS FOR APPROVAL / REVIEW	1076 of 3638	The documents listed below required to be submitted to OWNER / CONSULTANT directly or arranged from Cost plus contractor which is applicable for the purpose of either approval or review/comments as mentioned against each item.	<b>Modification</b>  The documents listed below required to be submitted to <b>PMC and copied to Owner</b> for the purpose of either approval or review/comments as mentioned against each item.
47.	Volume_II_Technical_Section_Part_1	Part II – Technical Part, DOCUMENTS/ DRAWINGS FOR OWNER’S/ PMC’S REVIEW / 4. Documents / Drawings for Approval, Review by Owner / PMC 4.3. FINAL DOCUMENTS	1078 of 3638	Final copies of P&IDs, plot plan, 3D model and all piping drawings, design calculation, stress analysis report & CD (Auto CAD version no. 14 or latest)	<b>Modification</b>  Final copies of P&IDs, plot plan, 3D model ( <b>in E3D</b> ) and all piping drawings, design calculation, stress analysis report (Auto CAD version no. 14 or latest).

		<b>MRPL Marketing Terminal Project at Devangonhi, Bangalore</b> <b>Marketing Infrastructure Projects, MRPL.</b>				
<b>LSTK-A PACKAGE : TANKAGE AND ASSOCIATED CIVIL, MECHANICAL, PIPING, ELECTRICAL, INSTRUMENTATION &amp; FIRE FIGHTING WORKS</b> <b>ADDENDUM 04</b>						
Sl. No.	Volume	Section No./Clause No.	Page No.	Existing Tender Clause	Addition / Deletion / Modification	
48.	Volume_II_Technical_Section_Part_1	Part II – Technical Part, MARKETING TERMINAL DESIGN BASIS MECHANICAL/ 7.12. INSTRUMENT AIR COMPRESSOR AND DRYER PACKAGE	1221 of 3638	Pressure dew point shall be selected suitable for Instrumentation Valves.	<b><u>Modification</u></b> Pressure dew point shall be <b>as per ISO 8573-1:2010 and should also</b> be suitable for Instrumentation items.	
49.	Volume_II_Technical_Section_Part_1	Part II – Technical Part, PACKAGE SCOPE OF WORK / 15. SCOPE OF WORKS FOR DESIGN OF TERMINAL 15.2. DETAILED SCOPE OF WORKS / 15.2.2	1362 of 3638	3D model: Overall in charge, Developing, integration of inputs from OTHER CONTRACTORS, stage wise review, recommendation based on mitigation, incorporation in design and at site.	<b><u>Modification</u></b> 3D model: Overall in charge, Developing, integration of inputs from OTHER CONTRACTORS <b>including with package suppliers</b> , stage wise review, and recommendation based on mitigation, incorporation in design and at site.	
50.	Volume_II_Technical_Section_Part_1	Part II – Technical Part, PACKAGE SCOPE OF WORK / 15. SCOPE OF WORKS FOR DESIGN OF TERMINAL 15.2. DETAILED SCOPE OF WORKS / 15.2.19	1363 of 3638	CONTRACTOR shall verify detail-sizing calculations given in the Bid. If sizes of any instrument, line or equipment provided in the bid are found to be inadequate, the same shall be revised to calculated sizes. However, minimum requirement with respect	CONTRACTOR shall verify detail-sizing calculations given in the Bid. If sizes of any instrument, line or equipment provided in the bid are found to be inadequate, the same shall be revised to calculated sizes. However, minimum requirement with respect to sizes mentioned in the bid shall be retained. Sizes, sizing calculations or related information supplied by the bidder in their bid shall be retained for information. CONTRACTOR shall resubmit the detail-sizing calculations for owner's review.	



 एन आर पी एल MRPL	<b>MRPL Marketing Terminal Project at Devangonhi, Bangalore</b> <b>Marketing Infrastructure Projects, MRPL.</b>	 nauvata ENGINEERING CONSULTANTS
	<b>LSTK-A PACKAGE : TANKAGE AND ASSOCIATED CIVIL, MECHANICAL,          PIPING, ELECTRICAL, INSTRUMENTATION &amp; FIRE FIGHTING WORKS</b> <b>ADDENDUM 04</b>	

Sl. No.	Volume	Section No./Clause No.	Page No.	Existing Tender Clause	Addition / Deletion / Modification
				to sizes mentioned in the bid shall be retained.	
51.	Volume_II_Technical_Section_Part_1	Part II – Technical Part, PACKAGE SCOPE OF WORK / 16. SCOPE OF WORK FOR MECHANICAL (TANK, PACKAGE AND PUMPS) / 16.1.5.16.	1370 of 3638	Design, supply and installation of all Instruments on tanks as required in data sheets, specifications and codes & standards (by other Contractor).	<b>Modification</b> Design, supply and installation of all Instruments on tanks as required in data sheets, specifications and codes & standards (by other Contractor). <b>However contractor shall provide nozzles, Stilwell and supports for the instruments as necessary.</b>
52.	Volume_II_Technical_Section_Part_1	Part II – Technical Part, PACKAGE SCOPE OF WORK / 16. SCOPE OF WORK FOR MECHANICAL (TANK, PACKAGE AND PUMPS) / 16.1.5.42	1372 of 3638	All welding electrodes, filler wires, flux etc.(as per approved vendors)	<b>Modification</b> All welding electrodes, filler wires, flux etc., as per approved vendors or as approved by PMC/OWNER or engineer in- charge
53.	Volume_II_Technical_Section_Part_1	Part II – Technical Part, PACKAGE SCOPE OF WORK / 16. SCOPE OF WORK FOR MECHANICAL (TANK, PACKAGE AND PUMPS) / 16.2. SCOPE OF WORK - MECHANICAL EQUIPMENT & PACKAGES / 16.2.1.7.	1378 of 3638	b) All equipment and its accessories, installed in the terminal shall be designed and selected / certified for electrical area classification defined in data sheets / design basis forming part of bid package.	<b>Modification</b> b) All equipment and its accessories, installed in the terminal shall be designed, selected, <b>certified and supplied as per</b> electrical area classification defined in data sheets / design basis forming part of bid package.



**MRPL Marketing Terminal Project at Devangonhi, Bangalore  
Marketing Infrastructure Projects, MRPL.**

**LSTK-A PACKAGE : TANKAGE AND ASSOCIATED CIVIL, MECHANICAL,  
PIPING, ELECTRICAL, INSTRUMENTATION & FIRE FIGHTING WORKS**

**ADDENDUM 04**



Sl. No.	Volume	Section No./Clause No.	Page No.	Existing Tender Clause	Addition / Deletion / Modification
54.	Volume_II_Technical_Section_Part_1	Part II – Technical Part, PACKAGE SCOPE OF WORK / 16. SCOPE OF WORK FOR MECHANICAL (TANK, PACKAGE AND PUMPS) / 16.2. SCOPE OF WORK - MECHANICAL EQUIPMENT & PACKAGES / 16.2.1.9	1379 of 3638	NEW ADDITION	<b>Addition</b> CONTRACTOR's scope of work shall include but not limited to: l) Supply of all type of spares including mandatory spares m) Any item or equipment as a result of HAZOP report.
55.	Volume_II_Technical_Section_Part_1	Part II – Technical Part, PACKAGE SCOPE OF WORK / 16. SCOPE OF WORK FOR MECHANICAL (TANK, PACKAGE AND PUMPS) / 16.2. SCOPE OF WORK - MECHANICAL EQUIPMENT & PACKAGES / 16.2.2. DETAILED SCOPE OF WORK FOR MECHANICAL EQUIPMENT & PACKAGES: / 16.2.2.3.	1379 of 3638	CONTRACTOR shall carry out the following activities for Design, Procurement, inspection, testing, and transportation, storage at site, Construction, erection, installation, Commissioning and site Testing of Equipment / Packages:	<b>Modification</b> CONTRACTOR shall carry out the following activities for Design, <b>Engineering</b> , Procurement, inspection, testing, and transportation, storage at site, Construction, erection, installation, Commissioning and site Testing of Equipment / Packages:
56.	Volume_II_Technical_Section_Part_1	Part II – Technical Part, PACKAGE SCOPE OF WORK / 16. SCOPE OF WORK FOR	1380 of 3638	List of deviations & all approved vendor drawings / documents by CONTRACTOR shall	<b>Modification</b> List of acceptable deviations & all approved vendor drawings / documents by CONTRACTOR shall be part of





**MRPL Marketing Terminal Project at Devangonhi, Bangalore  
Marketing Infrastructure Projects, MRPL.**

**LSTK-A PACKAGE : TANKAGE AND ASSOCIATED CIVIL, MECHANICAL,  
PIPING, ELECTRICAL, INSTRUMENTATION & FIRE FIGHTING WORKS**



**ADDENDUM 04**



Sl. No.	Volume	Section No./Clause No.	Page No.	Existing Tender Clause	Addition / Deletion / Modification
		MECHANICAL (TANK, PACKAGE AND PUMPS) / 16.2. SCOPE OF WORK - MECHANICAL EQUIPMENT & PACKAGES / 16.2.2. DETAILED SCOPE OF WORK FOR MECHANICAL EQUIPMENT & PACKAGES: / 16.2.2.4. DESIGN ENGINEERING AND PROCUREMENT / 16.2.2.4.10.		be part of the purchase specification submitted for PMC review and approval.	the purchase specification submitted for PMC review and approval.
57.	Volume_II_Technical_Section_Part_1	Part II – Technical Part, PACKAGE SCOPE OF WORK / 17. SCOPE OF WORK FOR TANK FOUNDATION & DYKE AREA (Civil / Structural) / 17.2.16. INSPECTION AND TEST PLAN /17.2.16.1	1401 of 3638	CONTRACTOR shall provide inspection test plans for carrying out the works for all tankage support & facilities.	<b><u>Modification</u></b> CONTRACTOR shall provide inspection test plans for carrying out the works for all tankage support & facilities <b>for PMC/OWNER approval. Contractor shall not proceed further without the approval of PMC/OWNER.</b>
58.	Volume_II_Technical_Section_Part_1	Part II – Technical Part, PACKAGE SCOPE OF WORK / 23. CONTRACTOR RESPONSIBILITIES	1453 of 3638	NEW ADDITION	<b><u>Addition</u></b> 1. Procurement, inspection and supply of items /equipment specified 2. Pipelines from PMHB Facility at Devangonhi terminal supply and laying

	<b>MRPL Marketing Terminal Project at Devangonhi, Bangalore</b> <b>Marketing Infrastructure Projects, MRPL.</b>	
	<b>LSTK-A PACKAGE : TANKAGE AND ASSOCIATED CIVIL, MECHANICAL,          PIPING, ELECTRICAL, INSTRUMENTATION &amp; FIRE FIGHTING WORKS</b> <b>ADDENDUM 04</b>	

Sl. No.	Volume	Section No./Clause No.	Page No.	Existing Tender Clause	Addition / Deletion / Modification
59.	Volume_II_Technical_Section_Part_1	Part II – Technical Part, PACKAGE SCOPE OF WORK / 19. SCOPE OF WORK FOR FEED PIPELINE (FROM PMHBL MANIFOLD TO MRPL PLT MANIFOLD)/ 19.20.10	1432 OF 3638	Supply and providing 300-micron epoxy on the external surface of all 6” CS conduits meant for OFC	<b><u>Deleted</u></b>

 <b>ONGC</b> एन आर पी एल <b>MRPL</b>	<b>MRPL Marketing Terminal Project at Devangonhi, Bangalore</b> <b>Marketing Infrastructure Projects, MRPL.</b>	 <b>nauvata</b> ENGINEERING CONSULTANTS
	<b>LSTK-A PACKAGE : TANKAGE AND ASSOCIATED CIVIL, MECHANICAL,          PIPING, ELECTRICAL, INSTRUMENTATION &amp; FIRE FIGHTING WORKS</b> <b>ADDENDUM 04</b>	

Sl. No.	Volume	Section No./Clause No.	Page No.	Existing Tender Clause	Addition / Deletion / Modification
60.	Volume_II_Technical_Section_Part_1	Part II – Technical Part, PACKAGE SCOPE OF WORK /Clause number 21.4.9	1444 of 3638	PMC/OWNER shall provide suitable rated 415V, 3-phase; 4 wire AC supply up to the field Sub Power Distribution Board (SPDB) / MOV DBs supplied by CONTRACTOR. If any other supply other than 415V AC, CONTRACTOR shall derived internally by providing Step up/down transformer, DB etc. Further distribution from SPDB / MOV DB's to individual MOVs/DBBVs including supply & laying of cable, cable tray & supports etc. by CONTRACTOR	<p><b><u>Modification</u></b></p> <p>PMC/OWNER shall provide suitable rated 415V, 3-phase; 4 wire AC supply up to the field Sub Power Distribution Board (SPDB) / MOV DBs supplied by CONTRACTOR. If any other supply other than 415V AC, CONTRACTOR shall derived internally by providing Step up/down transformer, DB etc. Further distribution from SPDB / MOV DB's to individual MOVs/DBBVs including supply &amp; laying of cable, cable tray &amp; supports etc. by CONTRACTOR. Whereas At PMHBL side, CONTRACTOR to supply &amp; install cable and cable tray &amp; its supports from existing spare feeder to field DBs and field DBs to MOVs/DBBVs.</p>





**MRPL Marketing Terminal Project at Devangonhi, Bangalore  
Marketing Infrastructure Projects, MRPL.**



**LSTK-A PACKAGE : TANKAGE AND ASSOCIATED CIVIL, MECHANICAL,  
PIPING, ELECTRICAL, INSTRUMENTATION & FIRE FIGHTING WORKS**

**ADDENDUM 04**





Sl. No.	Volume	Section No./Clause No.	Page No.	Existing Tender Clause	Addition / Deletion / Modification
61.	Volume_II_Technical_Section_Part_1	Part II – Technical Part, PACKAGE SCOPE OF WORK /Clause number 24.22	1455 of 3638	Supply & laying of power cables (except within package units and field SPDB/MOV DBs to individual MOVs/DBBVs supplied by CONTRACTOR.	<p><b><u>Modification</u></b></p> <p>Supply &amp; laying of power cables (except within package units and field SPDB/MOV DBs to individual MOVs/DBBVs supplied by CONTRACTOR and PMHBL side MOVs/DBBVs)</p>
62.	Volume_II_Technical_Section_Part_1	Part II – Technical Part, PACKAGE SCOPE OF WORK/ 21. Scope of Electrical	-	-	<p><b><u>Addition</u></b></p> <p><b><u>FACILITIES AT PMHBL PREMISES</u></b></p> <p>For feed pipeline at PMHBL side, CONTRACTOR shall supply and install MOVs/DBBVs at PMHBL premises. For details of PMHBL side MOVs / DBBVs, please refer the P&amp;ID enclosed as part of tender. FCU card (Modbus RTU type) with repeater shall be supplied for the MOVs /DBBVs Actuators which are marked in P&amp;IDs.</p> <p>Power supply for these MOVs / DBBVs PMC / OWNER shall arrange one (1) no. of spare feeder in the existing panel / DB of PMHBL switchgear room. Further CONTRACTOR to supply required no. of field DBs to connect these MOVs /DBBVs.</p> <p>CONTRACTOR to supply &amp; install cable and cable tray &amp; its supports from existing spare feeder to field DBs and field DBs to MOVs/DBBVs. The installation &amp; construction of all electrical equipment including cable tray (underground/above ground) shall be as per existing</p>



		<b>MRPL Marketing Terminal Project at Devangonhi, Bangalore</b> <b>Marketing Infrastructure Projects, MRPL.</b>				
		<b>LSTK-A PACKAGE : TANKAGE AND ASSOCIATED CIVIL, MECHANICAL,          PIPING, ELECTRICAL, INSTRUMENTATION &amp; FIRE FIGHTING WORKS</b>			<b>ADDENDUM 04</b>	
Sl. No.	Volume	Section No./Clause No.	Page No.	Existing Tender Clause	Addition / Deletion / Modification	
					<p>philosophy of PMHBL and same shall be finalised during in the course of execution of the project.</p> <p>CONTRACTOR shall check any space available in the existing cable tray to route the cable else provide new cable tray &amp; supports to lay the cable from existing spare feeder to Field DBs and filed DBs to MOVs /DBBVs.</p> <p>During execution of work if any underground or above ground existing facilities are encountered, the contractor shall ensure that the new facilities do not interfere with existing facilities.</p> <p>CONTRACTOR SCOPE of work shall include design, supply, installation, testing, commissioning of MOVs / DBBVs, cable &amp; its termination (including PMHBL side), cable tray &amp; its supports, buried cable trench (if required) and complete the work in all respects.</p>	
63.	Volume_II_Technical_Section_Part_1	Part II – Technical Part, PACKAGE SCOPE OF WORK / 18. Scope of work of Piping/	1413 of 3638	-	<p><b>Addition</b></p> <p>18.5.62 For all the works related to hook-up with the existing facilities at PMHBL, following activities are in Contractor scope</p> <ol style="list-style-type: none"> <li>i. Emptying of the residual content of the pipes/system, cleaning/flushing and inertizing with nitrogen before hot work.</li> <li>ii. Obtaining daily Hot work permit (as and when required to complete the job).</li> </ol>	

		<b>MRPL Marketing Terminal Project at Devangonhi, Bangalore Marketing Infrastructure Projects, MRPL.</b>				
		<b>LSTK-A PACKAGE : TANKAGE AND ASSOCIATED CIVIL, MECHANICAL, PIPING, ELECTRICAL, INSTRUMENTATION &amp; FIRE FIGHTING WORKS</b>			<b>ADDENDUM 04</b>	
Sl. No.	Volume	Section No./Clause No.	Page No.	Existing Tender Clause	Addition / Deletion / Modification	
					iii. Planning and scheduling of hot works to be communicated to PMC/PMHBL in advance. iv. Barricading the surrounding areas for hot works. v. Providing water curtain wherever required. vi. Developing the procedure for barricading and get its approval from PMC/PMHBL.	
64.	Volume_II_Technical_Section_Part_1	Part II – Technical Part, PACKAGE SCOPE OF WORK / 16. SCOPE OF WORK FOR MECHANICAL (TANK, PACKAGE AND PUMPS)/ 16.2.4.10	1391 OF 3638	-	<b><u>Modification,</u></b>  The referred page number are replaced with attached page from Sheet 57 of Addendum 4.	
65.	Volume_II_Technical_Section_Part_1	Part II – Technical Part, PACKAGE SCOPE OF WORK / 21. SCOPE OF WORK FOR ELECTRICAL/ 21.1.14	1440 of 3638	-	<b><u>Addition</u></b>  v) Complete Cathodic Protection (CP) system for the pipelines	
66.	Volume_II_Technical_Section_Part_1	Part II – Technical Part, PACKAGE SCOPE OF WORK / 21. SCOPE OF WORK FOR ELECTRICAL/ 21.2.1	1442 of 3638	-	<b><u>Addition</u></b>  xxxiii) ICCP Cathodic protection system design by certified CP contractor for buried pipelines (underground vessels/structures if required). Supply of all necessary materials for both temporary and permanent cathodic protection. CONTRACTOR to submit all drawings related to CP system like calculations, GAD, drawings etc.	





 <b>ONGC</b> एन आर पी एल <b>MRPL</b>	<b>MRPL Marketing Terminal Project at Devangonhi, Bangalore</b> <b>Marketing Infrastructure Projects, MRPL.</b>	 <b>nauvata</b> ENGINEERING CONSULTANTS
	<b>LSTK-A PACKAGE : TANKAGE AND ASSOCIATED CIVIL, MECHANICAL,          PIPING, ELECTRICAL, INSTRUMENTATION &amp; FIRE FIGHTING WORKS</b> <b>ADDENDUM 04</b>	

Sl. No.	Volume	Section No./Clause No.	Page No.	Existing Tender Clause	Addition / Deletion / Modification
67.	Volume_II_Technical_Section_Part_1	Part II – Technical Part, PACKAGE SCOPE OF WORK / 21. SCOPE OF WORK FOR ELECTRICAL/ 21.3.1	1443 of 3638	-	<u><b>Addition</b></u>  xvii) Cathodic protection materials necessary for both temporary and permanent cathodic protection mainly impressed current Transformer Rectifier unit, Permanent and sacrificial anodes, junction boxes, cabling and other accessories
68.	Volume_II_Technical_Section_Part_1	Part II – Technical Part, PACKAGE SCOPE OF WORK / 21. SCOPE OF WORK FOR ELECTRICAL/ 21.4.8	1444 of 3638	Buried pipeline, which required CP system shall be supplied by CONTRACTOR and provide the required information to PMC/OWNER to design complete CP system for these pipelines.	<u><b>Modification</b></u>  Presently, assumed that the CP transformer rectifier unit shall be locating at substation room. However, the exact location of these transformer rectifier unit shall be finalized during detail engineering by the BIDDER. OWNER shall provide AC power supply 415V, 50HZ and incoming cable up to the transformer rectifier unit only. Further complete CP system design including supply and installation of transformer rectifier unit, TCP & ICCP, cables / special cables, cable trays, cable trench/ buried cable trench etc. by LSTK- A CONTRACTOR.
69.	Volume_II_Technical_Section_Part_1	Part II – Technical Part, PACKAGE SCOPE OF WORK / 24. MAJOR EXCLUSIONS FOR CONTRACTOR / 24.26	1456 of 3638	Design & Supply of Cathodic Protection system (By OTHER CONTRACTOR) for buried pipelines, supplied by CONTRACTOR.	<u><b>Deleted</b></u>



	<b>MRPL Marketing Terminal Project at Devangonhi, Bangalore</b> <b>Marketing Infrastructure Projects, MRPL.</b>	
	<b>LSTK-A PACKAGE : TANKAGE AND ASSOCIATED CIVIL, MECHANICAL,          PIPING, ELECTRICAL, INSTRUMENTATION &amp; FIRE FIGHTING WORKS</b> <b>ADDENDUM 04</b>	

**Annexure 03 – Technical Clarification.**

Sl. No.	BIDDING DOCUMENT		SUBJECT	BIDDER'S QUERY	PMC/OWNER'S REPLY
	PAGE No.	CLAUSE No.			
1		Piping and Instrumentation Diagram for Fire Fighting System (20005-GEN-P-PID-1013_2	Fire Fighting network and equipment layout (hydrant, Monitor, HVLRM etc) need to be considered only in the tank farm area as shown in the attached tender Schematic.	From the schematic Bidder understand that hydrant layout across TT Parking area, Tank Truck loading bay, TLF Pump House etc are not in LSTK -A. Please confirm. However bidder propose that the entire firefighting should have been with LSTK A as overall Fire water demand is in their (LSTK A) responsibility as part of detail engineering. Please confirm.	Bidder understanding is incorrect, Firewater network including hydrants and monitors for all the areas of the terminal including TT Parking area, Tank Truck loading bay, TLF Pump House etc. are in LSTK_A bidder scope, Refer to scope demarcation in the P&ID 20005-GEN-P-PID-1013_2 and scope of work document. We confirm that the entire firefighting scope except the firewater hydrants inside the buildings like Admin/office, control room, canteen and clean agent system for control room are in LSTK-A bidder scope,
2		Fire Fighting - for Transformer	-	Tender document doesn't mention the type / tech data sheet of transformer in the proposed terminal. Kindly provide the type of Transformer / the technical data sheet of or the Oil storage Capacity enabling to consider the Fire Fighting system accordingly	Bidder to note the details transformer details. a) Transformer rating: 1MVA (2nos.) b) Type: Oil filled type c) Voltage: 11kV/415V Also please find the attached 20005-GEN-E-SPE-5003 Standard specification for oil filled transformer along with Addendum 4 for your reference. Supply of

 <b>ONGC</b> एन ओर पी एल <b>MRPL</b>	<b>MRPL Marketing Terminal Project at Devangonhi, Bangalore</b> <b>Marketing Infrastructure Projects, MRPL.</b>	 <b>nauvata</b> ENGINEERING PROJECTS & SERVICES
	<b>LSTK-A PACKAGE : TANKAGE AND ASSOCIATED CIVIL, MECHANICAL,          PIPING, ELECTRICAL, INSTRUMENTATION &amp; FIRE FIGHTING WORKS</b> <b>ADDENDUM 04</b>	

Sl. No.	BIDDING DOCUMENT		SUBJECT	BIDDER'S QUERY	PMC/OWNER'S REPLY
	PAGE No.	CLAUSE No.			
					Transformed is not in the scope of Bidder.
3		Fire Fighting System - Deluge Valves		Medium velocity water spray across product tanks will be actuated by Linear heat sensing cables only. Hence no quartzite bulb detectors are required. Also the spray will be initialized by manual operation only. Hence automatic pneumatic/wet type deluge valve system need not to be considered. Please confirm.	Bidder understanding is correct. However, bidder shall ensure that the design and construction of fire protection shall meet the requirements of latest OISD and PNGRB guidelines, as applicable.
4		Building Fire Protection		Bidder also understand that inside building fire protection, landing valve, Hose Reel, Portable Fire Extinguisher, Clean agent extinguishing system etc are not under LSTK -A vendor scope. Please confirm.	Bidder understanding is correct, However bidder to note that firefighting system for TLF sheds/Pump house, TT parking area, VRU, Coalescer package units, OWS unit, STP/ETP, WTP unit and all other areas are in LSTK-A bidder scope .(The firefighting system inside RCC buildings like Admin/office, canteen, Control room are not in LSTK-A bidder scope).

	<b>MRPL Marketing Terminal Project at Devangonhi, Bangalore</b> <b>Marketing Infrastructure Projects, MRPL</b>					
	Part – C	<b>PACKAGE</b> <b>SCOPE OF WORK</b>			Tender No :	3200000495
	Section – C-1				Document No:	20005-GEN-S-SOW-2015
Subsection – -	Rev :		1			

## 19. SCOPE OF WORK FOR FEED PIPELINE (FROM PMHBL MANIFOLD TO MRPL PLT MANIFOLD)

### 19.1. GENERAL

19.1.1. Work tendered in this bid package consists Detail Engineering, Procurement, Supply, Installation, Testing, Pre-commissioning and Commissioning of 14” Pipeline at MRPL Marketing Terminal, Devangonhi, Bengaluru.

19.1.2. Proposed Pipeline scope of work involved shall be as below

- a. Design, Supply and **Laying of 3 Nos. of 14” HSD, ATF and MS product** Pipelines from Manifold located inside PMHB Facility at Devangonhi to PLT manifold inside MRPL Marketing Terminal.
- b. 2 number of OFC shall be laid **along with the proposed 3 Nos. of pipelines** from Manifold located inside PMHB Facility at Devangonhi to PLT manifold inside MRPL Marketing Terminal.
- c. Carrying out all topographical and geo-technical surveys, as required, preparation of crossing drawing, procedures and submitting the same for PMC / MRPL’s approval. Installation works shall start only after getting PMC / MRPL approval of design document.
- d. All works related to hydro testing and pre-commissioning & Overall Commissioning of the pipeline.
- e. Crossings of road, utilities and Existing underground pipelines crossings by Open cut, HDD and boring.
- f. Any other work not mentioned but required for successful completion of work.



### 19.2. BRIEF DESCRIPTION OF WORK



19.2.1. The CONTRACTOR’s scope for the work tendered shall consist of, but not limited to, surveys, procurement engineering, Detailed Design engineering & installation engineering, testing, pre-commissioning of complete pipelines system including piping works at both Manifolds; hook-up with existing and proposed facilities and commissioning assistance with all associated mechanical, civil, structural, electrical, instrumentation works and all such works which though specifically not indicated here but will otherwise require to complete the work in all respect. This shall be read in conjunction with the pipeline design basis No. 20005-GEN-PL-EDB-7010.

19.2.2. As part of proposed **3 Nos. of 14” pipelines design for HSD, ATF and MS products**, following design activities have to be performed,



- a. Wall thickness calculation;
- b. Pipe stresses computation from PMHB Manifold to PLT Manifold (after U/G to A/G transition)
- c. Pipe floatation check;
- d. Road crossing design check;
- e. Upheaval buckling check, and,
- f. Allowable static free span for construction phase

19.2.3. Pipeline design parameters are outlined in the Pipeline Design Basis, 20005-GEN-PL-EDB-7010. Pipeline shall be designed for Maximum Design Temperature and Design Pressure.

	<b>MRPL Marketing Terminal Project at Devangonhi, Bangalore</b> <b>Marketing Infrastructure Projects, MRPL</b>				
	<b>Part – C</b>	<b>PACKAGE</b> <b>SCOPE OF WORK</b>	Tender No :		3200000495
	<b>Section – C-1</b>		Document No:		20005-GEN-S-SOW-2015
<b>Subsection – -</b>	Rev :		1		

19.2.4. The pipe wall thickness calculations shall be performed in accordance with ASME B31.4 [Ref.8] for pressure containment criteria. Design factor / Corrosion allowance for operating condition shall be as per the Design Basis / and also as per Code specified in the Design basis (20005- GEN-PL-EDB-7010).

19.2.5. Pipe stresses shall be computed using CEASAR II / Auto pipe software for the section of Pipeline including the manifold arrangements. CONTRACTOR to ensure that the Stress Analysis shall be performed from the existing PHMBL Manifold to proposed MRPL PLT Manifold. All the details beyond the battery limit / Spec break shall be as per the detailed P&IDs which will be generated by CONTRACTOR during Detailed engineering phase **and the same shall be issued for PMC / MRPLs approval.**

Battery Limit / spec break referred in the P&IDs (20005-GEN-P-PID-1005) are tentative. LSTK shall prepare the detailed P&IDs during detailed engineering phase and the same shall be considered for performing the analysis. Stress analysis report shall be issued to PMC for review and approval.

CONTRACTOR to ensure that details at the existing manifold shall be obtained by PMHBL before performing the analysis.

Pipe stresses due to temperature, pressure and seismic loading shall be computed in accordance with ASME B31.4 for restrained and unrestrained pipeline sections for hydro test and operating conditions.



19.2.6. The proposed pipeline route has crossings with existing U/G infrastructure (pipelines, cables etc.). **The details and burial depth of the existing pipelines shall be obtained by the contractor during survey and the same shall be issued to PMC for approval.** At existing crossing locations of PMHB pipeline, proposed pipeline profile shall follow the burial depth of PMHB pipeline otherwise pipeline profile to be designed such that minimum clearance of 500mm is achieved between the new pipeline and existing U/G infrastructure. Vertical clearance (as per Code OISD 141) shall be achieved either by providing bends or by adopting an appropriate trench profile to suite the adjacent pipeline profile.

19.2.7. The proposed pipeline route also crosses several roads / Compound Wall / Fencing. These roads are mostly **with or without heavy vehicular traffic. The details shall be obtained by contractor before engineering and the same shall be adopted during their Detailed engineering phase.** The pipe stresses at road and plant road crossings shall be assessed in accordance with API RP 1102 based on cased / uncased crossing design and the results along with Mechanical Design Report shall be provided to MRPL / PMC for approval.

19.2.8. Proposed Pipeline shall be trenched and buried as per the Codes and Standards and shall be checked for Upheaval buckling considering operating conditions for trench imperfection heights ranging from 0.2m to 0.6m.

19.2.9. The proposed pipelines shall be protected against external corrosion by means of impressed current cathodic protection system (ICCP) and shall be documented in a separate dedicated report.

19.2.10. Other proposed facilities and piping beyond the designated Battery Limit Point as indicated in the Sketch (20005-GEN-PL-SK001) at both Manifold ends (Existing PMHB Manifold and proposed PLT Manifold at MRPL terminal), is indicated in "Piping Project Scope of work" Doc No. 20005-GEN-L-SOW-3104A. **Sketch 20005-GEN-PL-SK001 is tentative. The same shall**

	<b>MRPL Marketing Terminal Project at Devangonhi, Bangalore</b>		
	<b>Marketing Infrastructure Projects, MRPL</b>		
	<b>Part – C</b>	<b>PACKAGE SCOPE OF WORK</b>	
<b>Section – C-1</b>	Document No: 20005-GEN-S-SOW-2015		
<b>Subsection – -</b>		Rev : 1	



be revised and modified accordingly based on the completion of survey and all the complete details regarding the existing facilities obtained from PMHB

19.2.11. This section is not intended to be all-inclusive and shall be read in conjunction with specifications/ drawings and other requirements of the Bid Package. The use of the guidelines set forth in the Bid Package does not relieve the LSTK CONTRACTOR of his responsibility in performing the work for its intended purpose. The CONTRACTOR, however, shall obtain written approval from PMC for any deviation from the requirements of the Bid Package.

19.2.12. CONTRACTOR to consider following points as a minimum for installation of Pipeline

1. Pipeline routes (for 3 Nos.) indicated is tentative, LSTK CONTRACTOR to finalize the pipeline route during detailed engineering.
2. LSTK CONTRACTOR to ensure the proposed 3 Nos. of 14" pipelines for MS, HSD and ATF is laid with clear distance of 500mm between the proposed pipelines and 3m from existing PMHB pipeline.
3. 3 numbers of borehole data shall be collected along the pipeline route. However, borehole locations indicated are tentative and shall be finalized during detailed engineering, by LSTK contractor. (Please refer the sketch attached – 20005-GEN-PL-SK001)
4. Existing facilities, if any interfering with the proposed 3 Nos. of 14" pipelines shall be removed and reinstated to its original position and condition without any additional time and cost by LSTK contractor.
5. LSTK CONTRACTOR to ensure the proposed 3 Nos. of 14" pipelines is laid to match burial depth of existing PMHB pipeline at crossing location and proposed pipeline laid below the existing PMHB pipelines wherever required. The same is shown in Sketch No. 20005-GEN-PL-SK001. However, Contractor to note that the sketch provided is tentative. The Crossing shall be designed and engineered by LSTK CONTRACTOR based on actual survey. CONTRACTOR shall obtain the necessary approval / permissions by the OMCs during this activity.
6. LSTK CONTRACTOR to obtain prior approval from PMC/MRPL, if increase in Pipeline length and number of crossings occurs during detailed engineering. CONTRACTOR shall not claim for additional cost and time.
7. Wherever usage of cold field bends (as per CODE OISD141) are not feasible during pipeline laying, 5D bends shall be used.
8. CONTRACTOR shall firm up configuration of 3 Nos of proposed pipelines from PMHBL manifold tie-in point inside the PMHB pipeline's ROW during detailed engineering phase or mark a new ROW along the pipeline route (for 3 Nos. of Proposed Pipelines) based on the survey. Based on the new ROW considered, contractor shall do the soil investigation and survey report to be issued to PMC / MRPL approval. New ROW drawings shall be also issued to PMC / MRPL approval. Tentative ROW is shown in the sketch No. 20005-GEN-PL-SK001. The same shall be finalized during detailed engineering phase. CONTRACTOR shall obtain necessary approval by PMHB authorities for the same.
9. Design, Supply, installation, testing and commissioning of all required materials including, Pipes, Pipefitting like Flanges, Bends, reducers ,etc. installations like MOVs with power cable till control room (in PMHBL premises), or any other type of valves as per detailed design, OFCs, their laying, CP system, etc.





	<b>MRPL Marketing Terminal Project at Devangonhi, Bangalore</b> <b>Marketing Infrastructure Projects, MRPL</b>			
	<b>Part – C</b>	<b>PACKAGE</b> <b>SCOPE OF WORK</b>		Tender No : 3200000495
	<b>Section – C-1</b>			Document No: 20005-GEN-S-SOW-2015
<b>Subsection – -</b>	Rev : 1			

**19.2.13. Contractor shall note following points while Laying 3 pipelines through the existing Village road after exiting from PMHBL premises.**

1. 3 Nos. of proposed pipelines (14" for HSD, MS and ATF products) will be installed starting from PHMB Manifold laid via alongside of the bitumen topped village road road and will be tied in at the MRPL PLT as indicated in 20005-GEN-PL-SK001 SHT 2 OF 2. For tie-in at PMHBL manifold, contractor to refer the drawing 20005-GEN-PL-SK001 SHT 1 OF 2. The schematics are indicative and contractor to refer respective P&IDs for actual tie-in at PMHB manifold and MRPL PLT Manifold attached elsewhere in the Tender document.
2. In locations, where pipeline has to be laid in the body / alongside of the village bitumen road, contractor to obtain necessary permissions / approval from village panchayat / other government agencies to open cut the bitumen road. Wherever the pipeline Right of Use (ROU) runs alongside of the road, contractor shall grade the width of the ROU necessary for digging the pipeline trench and constructing / laying of pipeline. In the said places Contractor shall carry out the works in such a way that the damage resulting from the pipeline construction is kept minimum. The length of the pipeline to be laid alongside the road shall be obtained during per-engineering survey. The same shall be issued to PMC / MRPL for review and approval.
3. Contractor to note that the bitumen topped village road / paving dug for proposed 3 Nos of pipeline installation throughout shall be restored to its original condition after the pipeline is installed. The restoration of entire width of the road (approximately 7m) with Bitumen topping as per the specification will also be under the scope of Contractor. Width of the road shall be verified / obtained during pre-engineering survey and shall be issued for issued for PMC / MRPL review. The same shall be carried by the Contractor without any time and cost implications.
4. During the course of the job, contractor shall ensure that the normal transportation on the road shall not get affected. For this the contractor shall provide alternative road temporarily by widening the existing village road to the other side or contractor shall take approval from concerned authorities and shall arrange for alternate route to normalize the transportation. Necessary detour sign boards and barricades shall be arranged by the contractor for the same purpose.
5. Restoration of the road shall be done in the following procedure.
  - a. The contractor shall compact the subgrade soil as per the standard specification.
  - b. 02 layer of graded WMM shall be laid on the prepared surface, 150mm each (total thickness 300 mm) with proper grading and compaction .
  - c. One coat of 75mm thick Bituminous Macadam shall be laid on prepared surface of WMM with bitumen of VG30 grade @ 4.0% (Percentage by weight of total mix) including tack coat. Followed by 50 mm Premix Carpet surfacing, including a tack coat with hot straight run bitumen, compaction with road roller of 9 tonne capacity with paving Asphalt grade VG - 10. heated and then mixed with solvent at the rate of 70 grams per kg of asphalt.
  - d. Seal coat shall be provided over prepared surface of premix carpet with bitumen/ heated bitumen fitted with the spray set spraying using 98 kg bitumen of grade of 80/100 binding surface for 100 Sqr-Mtr of road with proper graded material including rolling and finishing with road roller.
  - e. Road shoulder shall be filled with proper soil/ WMM ensuring the safety of the side of the road.





	<b>MRPL Marketing Terminal Project at Devangonhi, Bangalore</b> <b>Marketing Infrastructure Projects, MRPL</b>			
	<b>Part – C</b>	<b>PACKAGE</b> <b>SCOPE OF WORK</b>	Tender No : 3200000495	
	<b>Section – C-1</b>		Document No: 20005-GEN-S-SOW-2015	
<b>Subsection – -</b>	Rev : 1			

- 19.2.14. Appraisal and taking cognizance of site-conditions, Indian Government/ State government rules and regulations, bye-laws, applicable codes and standards, requirements of authorities having jurisdiction over the work site(s), environmental and pollution concerns including conditions / stipulations laid down by the concerned authorities etc. is pre-requisite. CONTRACTOR is deemed to have recognized any restrictive features of the site(s) and / or specific requirements of the work and made due allowance for it in the work to be performed by him.
- 19.2.15. Obtaining all necessary approvals and work permits, gate passes from concerned authorities having jurisdiction, as applicable for performing the works including excavation, all types of cold, hot and height works, shifting/ relocation of existing facilities and other utilities etc., as required by local authorities and as directed by PMC / MRPL.
- 19.2.16. CONTRACTOR at all times shall ensure that all necessary permission/ clearances/ work permits are obtained and are up to date as required during survey, construction, testing and other phases of work.
- 19.2.17. CONTRACTOR shall inform all local authorities in advance and obtain all necessary approvals and work permits from concerned authorities having jurisdiction for crossing underground utilities/pipelines wherever encountered along the pipeline route. PIPELINE CONTRACTOR shall be required to carry out all the works as mentioned in the work permit. The scope of CONTRACTOR would include implementation of all the conditions of statutory approval.
- 19.2.18. CONTRACTOR shall prepare and submit all calculation books including specifications & data sheets, vendor data books, all survey reports, inspection and testing reports etc. as part of as-built dossiers for the complete pipeline system including Manifold Details at PMHBL Terminal and proposed MRPL PLT Terminal respectively.
- 19.2.19. Providing & mobilizing all construction spreads & equipment as required for receipt, lifting and laying, inspection and testing of onshore pipelines, associated piping works at existing PMHBL and proposed MRPL PLT Manifold.
- 19.2.20. All construction spreads shall be fully equipped and fully manned with required tools and tackles, support facilities and consumables etc. needed for successful execution of the works.
- 19.2.21. CONTRACTOR shall provide assistance for successful commissioning of complete pipeline system including Manifold stations.

### 19.3. SITE VISIT

- 19.3.1. Bidders are advised to make site visits along the pipeline route prior to quoting to familiarize themselves with all the salient features of terrain, availability of ROU and infrastructure along the pipeline route.
- 19.3.2. CONTRACTOR shall be deemed to have considered all constraints and eventualities on account of site conditions along pipeline route while formulating his bid.



	<b>MRPL Marketing Terminal Project at Devangonhi, Bangalore</b>			
	<b>Marketing Infrastructure Projects, MRPL</b>			
	<b>Part – C</b>	<b>PACKAGE SCOPE OF WORK</b>	Tender No :	
<b>Section – C-1</b>	Document No:		20005-GEN-S-SOW-2015	
<b>Subsection – -</b>		Rev :	1	

19.3.3. CONTRACTOR shall not be eligible for any compensation in terms of cost and/or time, on account of site conditions along pipeline route varying to any extent from whatever is described in the bid package.

#### 19.4. SOIL INVESTIGATION

19.4.1. It shall be CONTRACTOR's responsibility to familiarize himself with sub-soil conditions along the pipeline route, and workout the lengths of pipeline to be laid in different subsoil conditions including the quantum of asphalt/ concrete road cutting / excavation that would be necessary. Price quoted by Bidder shall also be inclusive of all excavation. No extra compensation shall be payable to CONTRACTOR later on.

#### 19.5. GENERAL PIPELINE DESIGN DATA

##### 19.5.1. DESIGN LIFE

Pipeline Design life is same as the design life of the production facilities which is 25 years

##### 19.5.2. COORDINATE SYSTEM

Coordinate system shall be as per the Topographical and Geotechnical survey by others.

##### 19.5.3. MATERIAL DATA

The proposed pipeline details are as indicated below:



Sl. No.	Onshore Pipeline Details			Nominal diameter (inch / mm)	Grade	Minimum Nominal wall thickness	Service
	Designation	From	To				
1	Pipeline # 1	PMHB Manifold	PLT Manifold at MRPL Terminal	14" (355.6mm)	API 5L Gr.B	14.3mm	Pipeline for MS
2	Pipeline # 2	PMHB Manifold	PLT Manifold at MRPL Terminal	14" (355.6mm)	API 5L Gr.B	14.3mm	Pipeline for HSD
3	Pipeline # 3	PMHB Manifold	PLT Manifold at MRPL Terminal	14" (355.6mm)	API 5L Gr.B	14.3mm	Pipeline for ATF
4	2 Nos. of OFC	Based on the Vendor design					

##### Note:

- CONTRACTOR to finalize the Wall thickness during Detailed Engineering Phase.
- Mother pipes for factory made induction bends and cold field bends shall be finalized as per the LR Bend Spec No. 200005-PL-SPE-7002

##### 19.5.4. MATERIAL PROPERTIES

The pipeline material properties are presented in table below:

	<b>MRPL Marketing Terminal Project at Devangonhi, Bangalore</b> <b>Marketing Infrastructure Projects, MRPL</b>				
	<b>Part – C</b>	<b>PACKAGE</b> <b>SCOPE OF WORK</b>	Tender No :		3200000495
	<b>Section – C-1</b>		Document No:		20005-GEN-S-SOW-2015
<b>Subsection – -</b>	Rev :		1		

Parameter	Unit	Description / Value
Line Pipe Material	-	Carbon Steel (CS)
Line Pipe Material Designation		API 5L Gr.B, PSL 2
Product		For MS, HSD, and ATF
Steel Density	kg/m <sup>3</sup>	7850
Young's Modulus of Elasticity	MPa	2.07x10 <sup>5</sup>
Poisson's Ratio		0.3
Coefficient of Expansion	/°C	1.17x10 <sup>-5</sup>
Specified Minimum Yield Strength (SMYS)	MPa	450
Specified Minimum Tensile Strength (SMTS)	MPa	535

#### 19.5.5. CORROSION ALLOWANCE

19.5.5.1. The internal corrosion allowance for pipelines shall be 3mm.

#### 19.5.6. ANTI-CORROSION COATING

19.5.6.1. The required external anti-corrosion coating for the onshore pipeline system is indicated in below table:

Description	Coating type	Min thickness	Density (kg/m <sup>3</sup> )*
Pipeline 3 Nos. of 14" MS, HSD and ATF pipelines from PMHB Manifold to MRPL PLT	3LPE	3.0mm	920
Bends	3LPE		
Monolithic Isolation Joint (MIJ)	Solvent free high build liquid epoxy coating		

\*Density value is approximate and shall be finalized by the CONTRACTOR during detailed engineering phase

#### 19.5.7. FIELD JOINT COATING

19.5.7.1. The field joint coating [FJC] for the pipeline shall be as per the Spec 20005-GEN-PL-SPE-7004 and shall be suitable to cater for pipeline operating conditions.



#### 19.5.8. OPERATIONAL DATA

19.5.8.1. The operational data applicable for pipeline design is outlined in the Design Basis (20005-GEN-PL-EDB-7010).

#### 19.5.9. CROSSING DETAILS

19.5.9.1. Number of crossings and type of crossing shall be obtained by carrying out pre-engineering survey during detailed engineering and the same shall be submitted to PMC for review/approval.

#### 19.5.10. LOCATION CLASS AND DESIGN FACTOR

	<b>MRPL Marketing Terminal Project at Devangonhi, Bangalore</b> <b>Marketing Infrastructure Projects, MRPL</b>			
	<b>Part – C</b>	<b>PACKAGE</b> <b>SCOPE OF WORK</b>	Tender No : 3200000495	
	<b>Section – C-1</b>		Document No: 20005-GEN-S-SOW-2015	
<b>Subsection – -</b>	Rev : 1			

19.5.10.1. Location class and design factor shall be as per applicable Codes and Standards (OISD 141 and OISD 226)

19.5.11. DESIGN FACTORS FOR STRESS ANALYSIS

- a. Design factors shall be considered in accordance with Table 403.3.1-1 of ASME B31.4
- b. Allowable Expansion stress shall be computed as per Section 403.3.2 of ASME B31.4

19.5.12. DESIGN CONDITION

Design Conditions	Pressure	Temperature	Content density	Corrosion Allowance
Operation case	Design	Design	Maximum	3mm
Hydro test case	Hydro test	Ambient	Water density	0mm

Maximum product density as a conservative case shall be considered for analysis

## 19.6. PIPELINE DESIGN

### 19.6.1. SURVEYS

19.6.1.1. CONTRACTOR to note that proposed 3 Nos. of 14" MS, HSD & ATF pipeline shall be laid in the existing PMHB pipeline corridor for some portion and new corridor to be considered as indicated in the sketch no. sketch No. 20005-GEN-PL-SK001. This sketch is only indicative. All the related documents shall be issued to PMC / MRPL approval as outlined in the other clauses.





19.6.1.2. CONTRACTOR shall collect relevant details regarding PMHB pipeline as indicated below and submit the same for PMC review and approval :

1. Existing corridor details.
2. Existing pipeline burial depth throughout the route.
3. Existing soil investigation report.
4. Existing pipeline burial depth at crossings.

19.6.1.3. CONTRACTOR to perform the survey and scope of work for surveys shall include but not be limited to following: -

- i. Carrying out pre-engineering survey of **the proposed 3 Nos. of pipelines route**/ corridor along with the existing PMHBL manifold and proposed MRPL PLT Manifold as per indicative drawings enclosed with the bid.
- ii. CONTRACTOR shall commence pre-engineering surveys immediately after award of the work and shall submit AutoCAD files of surveyed Alignment sheet containing contours, route profile, soil analysis results, existing pipeline, other features etc.
- iii. Pre-engineering survey shall also include carrying out topographical survey and geo-tech investigation survey for the entire pipeline route along with vibro-core samples as per indicative drawings enclosed with the bid.



	<b>MRPL Marketing Terminal Project at Devangonhi, Bangalore</b> <b>Marketing Infrastructure Projects, MRPL</b>				
	<b>Part – C</b>	<b>PACKAGE</b> <b>SCOPE OF WORK</b>	Tender No :		3200000495
	<b>Section – C-1</b>		Document No:		20005-GEN-S-SOW-2015
<b>Subsection – -</b>	Rev :		1		



- iv. Topographic surveys required to entire pipeline route & local detours during execution of the project shall be carried out by the CONTRACTOR prior to execution of job. However, laying and construction of entire pipeline including detoured portion shall be within the scope of CONTRACTOR and governed by scope of tender without any cost implication. CONTRACTOR shall be deemed to have considered such eventualities while formulating his bid. Pipeline route map/ alignment sheet showing the pipeline route shall be submitted to PMC for approval prior to execution of the works.
- v. This document shall be read in conjunction with 20005-GEN-PL-SPE-7006 (Specification for Pipeline construction)
- vi. Indicative plot plan drawing and tentative pipeline route along with tap-off is provided for reference purpose. Indicative drawing for underground pipeline design and construction is also included in the Bid package. These drawings are indicative only and shall be finalized during detailed engineering phase from LSTK Contractor. Final drawings marked “Issued for Construction” (IFC) shall be furnished by the CONTRACTOR at project execution stage. The IFC drawings may vary to some extent from the drawings included in Bid package. CONTRACTOR shall carry out all works in accordance with the IFC drawings.
- vii. Carrying out pre-construction surveys along proposed pipeline route for verification of pipeline route, data to obtain additional data and geotechnical investigations required for installation engineering and field installation of proposed facilities.
- viii. The CONTRACTOR shall be responsible for setting up correct positioning system and obtaining correct locations of proposed facilities, identification of existing pipelines/ cables/ utilities, if any, structures, CP interface (if any) and any other obstructions to the installation of pipelines, cables and finalization of pipeline route in the onshore section.
- ix. Carrying out post installation/ as-built surveys after successful hydrostatic testing of proposed pipeline system and generate information for preparation of as-built drawings and documents.

#### 19.6.2. WALL THICKNESS SELECTION

- 19.6.2.1. The required minimum wall thickness shall be computed for internal pressure containment (hoop stress) failure mode in accordance with ASME B31.4, whichever applies. Applicable internal corrosion allowance will be accounted for the wall thickness selection.
- 19.6.2.2. The required nominal pipe wall thickness shall be determined on the basis of pressure containment (i.e. hoop stress limitation).
- 19.6.2.3. Minimum line pipe wall thickness is provided in Clause 3.3. However, CONTRACTOR shall finalize the same during detail engineering phase.

#### 19.6.3. PIPE STRESSES

- 19.6.3.1. The selected wall thickness shall ensure pipe stresses to be within ASME B31.4 specified allowable limits during all design conditions over project design life.
- 19.6.3.2. Pipeline Stress Methodology, floatation Methodology and Upheaval buckling Methodology shall be performed and the Analysis reports shall be issued for MRPL/PMC’s approval.

	<b>MRPL Marketing Terminal Project at Devangonhi, Bangalore</b> <b>Marketing Infrastructure Projects, MRPL</b>					
	<b>Part – C</b>	<b>PACKAGE</b> <b>SCOPE OF WORK</b>			Tender No :	3200000495
	<b>Section – C-1</b>				Document No:	20005-GEN-S-SOW-2015
<b>Subsection – -</b>	Rev :		1			

19.6.3.3. CONTRACTOR to perform stress analysis from Existing PMHBL Manifold end to Proposed PLT Manifold end.

#### 19.6.4. CROSSING DESIGN

19.6.4.1. Crossing with Existing Facilities and Road Crossing shall be performed as outlined in Pipeline Design Basis (20005-GEN-PL-EDB-7010).

#### 19.6.5. UPHEAVAL BUCKLING

19.6.5.1. CONTRACTOR to perform the Upheaval buckling calculations and the same shall be provided for PMC review and approval.

#### 19.6.6. ALLOWABLE STATIC FREE SPAN LENGTH

19.6.6.1. The maximum allowable static span shall be calculated in pipe during empty condition for temporary situation like pipe stringing operation prior to lowering the pipeline into the trench.

19.6.6.2. Allowable Static free span length shall be calculated as per the Codes and standards the report /analysis shall be provided for PMC Approval.

#### 19.6.7. TRENCH SLOPE

19.6.7.1. The Complete pipeline route shall be trenched as per the codes and standards with reference to the site soil conditions. The angle of friction shall be considered as per the site soil conditions. Backfilling shall be done as per the specifications provided.

19.6.7.2. CONTRACTOR shall perform all the calculation required for design, installation and construction of onshore pipeline, not limited to the above specified requirement, and results along with the report shall be submitted to PMC approval.

#### 19.6.8. PIPE SUPPORTS

19.6.8.1. CONTRACTOR to design pipe supports for above ground pipeline/piping and design documents shall be issued for PMC approval.



19.6.8.2. Survey to be carried out by the CONTRACTOR to obtain actual height of Existing Manifold, height of existing above ground pipeline / piping at site or near plant area. Height of proposed Manifold shall be finalized during detail engineering.

19.6.8.3. CONTRACTOR to design pipe supports for above ground pipeline/piping at both terminals accordingly.

### 19.7. SUPPLY & PROCUREMENT

#### 19.7.1. SCOPE OF SUPPLY

19.7.1.1. All materials required for pipeline construction and associated facilities shall be supplied by CONTRACTOR. The procurement and supply, in sequence and at appropriate time and place, including inspection and expediting of all materials and consumables required for construction of pipeline as defined in the bid document shall be entirely the CONTRACTOR's responsibility.



	<b>MRPL Marketing Terminal Project at Devangonhi, Bangalore</b> <b>Marketing Infrastructure Projects, MRPL</b>				
	<b>Part – C</b>	<b>PACKAGE</b> <b>SCOPE OF WORK</b>	Tender No :		3200000495
	<b>Section – C-1</b>		Document No:		20005-GEN-S-SOW-2015
<b>Subsection – -</b>	Rev :		1		

All materials supplied by the CONTRACTOR shall be strictly in accordance with the requirements of relevant COMPANY's material specifications enclosed with the Contract document.



- 19.7.1.2. All equipment, materials, components etc. shall be new and specially purchased for this job from Company approved vendors, duly inspected by a Third Party Inspection Agency (TPIA) and cost for the TPIA charges shall be included in the quoted price. Quality control, inspection and expediting of all procured items at Vendor's shop or at fabrication yard shall be in CONTRACTOR's Scope of Work.
- 19.7.1.3. The Scope of Material Supply by CONTRACTOR for pipeline installation shall be read in conjunction with all relevant specifications and sub sections of Bid Package. All escalation/ extra material procured by the CONTRACTOR for contingencies shall be CONTRACTOR's property & no payment shall be made for such material.
- 19.7.1.4. Proven track record of all the Vendors for past 5 years shall be furnished for all the bought out items (including valves, fittings and flanges, pipes etc.). The Vendors who have supplied such items (of sizes as covered under present Bid Document) in the past shall only be proposed by CONTRACTOR.
- 19.7.2. CONTRACTOR shall procure and supply all materials what-so ever, required for permanent installation of subject pipelines, in sequence and at appropriate time for successful completion of complete pipeline system.
- 19.7.3. All equipment, materials, consumables, components etc. shall be new and suitable for the intended service. Necessary details i.e. data sheets & specifications, as required, are enclosed with the bid package. In case, for some items data sheets and/ or specifications are not available in the bid package, LSTK CONTRACTOR shall develop the same and submit to PMC for review & approval.
- 19.7.4. CONTRACTOR shall also procure and supply special tools and tackles and also to provide list of spare parts for normal operation, mandatory spares and spares required for pre-commissioning and commissioning/ start-up as recommended for all items supplied by him and as per specifications provided in the bid package.
- 19.7.5. CONTRACTOR shall finalize the item quantities for procurement with suitable escalations, as deemed necessary considering all contingencies so that at no point of time during execution of the pipeline system construction activities there shall be no shortage of any item to meet the project schedule.
- 19.7.6. CONTRACTOR shall note that the pipeline length provided in the Bid document is only for Estimation Purpose. Actual quantities of items required for Complete System of Pipeline Installation shall be procured by the CONTRACTOR.
- 19.7.7. CONTRACTOR to note that there is no free issue material envisaged in this project.

## **19.8. FABRICATION, INSTALLATION & TESTING**

- 19.8.1. CONTRACTOR's scope of work for fabrication, installation and testing shall include but not limited to the following.

	<b>MRPL Marketing Terminal Project at Devangonhi, Bangalore</b> <b>Marketing Infrastructure Projects, MRPL</b>				
	<b>Part – C</b>	<b>PACKAGE</b> <b>SCOPE OF WORK</b>	Tender No :		3200000495
	<b>Section – C-1</b>		Document No:		20005-GEN-S-SOW-2015
<b>Subsection – -</b>	Rev :		1		

- a. Fabrication of Bends including anti-corrosion coating or painting, as required. Bend angles shall be finalized and fabricated based on actual routing of pipeline from the existing PMHBL manifold to proposed PLT manifold.
- b. Transportation, load-out including packaging of all equipment, materials, components, consumables etc. from the fabrication yard to work site(s) shall be carried out by CONTRACTOR. CONTRACTOR shall also obtain statutory clearances from concerned government authorities on arrival at work site(s) of all the materials, equipment, components, consumables etc. required for permanent incorporation in pipeline system. Storage of materials and equipment etc. at work site(s) and during transit shall be the responsibility of the CONTRACTOR.
- c. Line pipe bends and other materials as per Scope of Supply, including loading, unloading, handling, arranging road/ rail/ including hauling of line pipes from the CONTRACTOR's own dump site(s)/ work site(s)/ workshop(s) to pipeline right-of-way, including arranging all pipe trailers, etc., arranging all necessary intermediate storage area(s) thereof till the pipes are installed in permanent installation. After award of works, CONTRACTOR shall visit the site to make the necessary arrangement and to propose the location of the DUMP SITE / Storage yards, for the items meant for permanent installation.
- d. Mobilizing and providing all equipment, construction spreads, manpower (skilled and unskilled), consumables and other resources etc., as required for the execution of complete work and thereafter demobilizing the same upon completion of work.
- e. Installation of pipeline from PMHBL distribution manifold to proposed MRPL PLT Terminal "including edge preparation, fit-up, beveling the line pipe to suit welding process, stringing, aligning, welding & NDT, including fabrication & installation of any cross overs etc. and application of paints and primers suitable for highly corrosive environment on above ground pipeline section along with all other fittings & accessories, supply of all materials & consumables; fabrication and installation of bends, tie-in/ hook-up with pipeline/ piping installed by others including cutting of temporary test headers, if any, ROU restoration and cleaning, pigging, gauging & hydrostatic testing, installation of pipeline at road crossing, installation of all types of markers, warning signs etc. as per contract requirements, standards and drawings and also as per applicable codes and standards.
- f. Obtaining all necessary approvals and work permits from COMPANY including hot work permit as applicable for performing the work in existing onshore facilities. Arranging of adequate firefighting equipment viz. Fire brigade, fire extinguisher, shielding from existing facilities, oxygen mask etc. for carrying out the work safely in existing terminals to the satisfaction of the COMPANY.
- g. Obtaining all necessary approvals and work permits from concerned authorities having jurisdiction, as applicable for performing the work including shifting/ relocation and restoration of telephone/ electrical poles and underground pipes and other utilities etc., as required by local authorities and as directed by PMC / MRPL. CONTRACTOR shall also obtain all necessary approvals and work permits from concerned authorities having jurisdiction for crossing underground utilities/ pipelines wherever encountered along the pipeline route. CONTRACTOR shall pre-inform the authority well in advance before execution of works.

	<b>MRPL Marketing Terminal Project at Devangonhi, Bangalore</b> <b>Marketing Infrastructure Projects, MRPL</b>				
	<b>Part – C</b>	<b>PACKAGE</b> <b>SCOPE OF WORK</b>	Tender No :		3200000495
	<b>Section – C-1</b>		Document No:		20005-GEN-S-SOW-2015
<b>Subsection – -</b>	Rev :		1		



- h. Pipeline / Piping Tie-in activities between existing PMHBL Manifold and proposed MRPL's PLT manifold including all supply (as included in CONTRACTOR's Scope of Supply), fabrication, installation & hydro testing of all pipeline / piping works, complete with insulating joints, valves, piping, fittings, flanges, inline instruments, CP requirements etc.; painting of above ground piping facilities as per specifications
- i. All civil & structural works including pedestal supports / foundations (If required) etc., electrical and instrumentation works, trenching, all hook-ups with pipeline & existing PMHBL manifold, all works up to designated Battery limits as per the detailed engineering documents by Contractor.
- j. Cathodic protection system for the proposed pipeline facilities is in the scope of contractor. Interface matrix is attached for reference. CP installation shall be carried out along with laying of pipeline. CP Vendor shall present / coordinate during the laying activities of the pipeline.
- k. Carrying out all hook-ups with proposed and existing facilities at PMHBL manifold and proposed MRPL PLT manifold respectively.
- l. Carrying out flushing, cleaning, gauging and hydrostatic pressure testing of pipelines and associated facilities in accordance with the specification enclosed with the Contract. The water used for Hydrostatic testing shall be treated water. The pipeline shall be tested from respective manifolds. Any activities/ equipment / material if any, required for hydro testing shall be supplied by the CONTRACTOR.
- m. Locating and repairs of leaks/bursts or any other defects observed during testing and retesting after repair of defects till successful hydrostatic testing is achieved.
- n. Preservation of pipeline, if required, shall be carried out in accordance with the requirements of bid package. Idle time preservation of the pipeline shall be carried out by filling with corrosion inhibited water. This clause shall be optional and applicable only when pipeline section is required to be preserved.
- o. The CONTRACTOR shall remove all materials, equipment, wastes/ scrap material etc. that do not form part of permanent systems. CONTRACTOR shall be responsible for clearing & restoration of all sites as per requirement of authorities having jurisdiction over the same and to the satisfaction of PMC / MRPL as part of his scope of work.
- p. Clean-up and restoration of ROW/ ROU and other conveniences like temporary approach roads/ temporary works, barren land, road, boundary walls, earthen bunds etc. to original condition as per specification and drawings to the entire satisfaction of PMC / MRPL and/or authorities having jurisdiction over the same.
- q. Any other works not specifically listed herein, but are required, for successful completion of entire works in all respects.



## 19.9. Optic Fiber Cables (OFC)

### 19.9.1. SCOPE FOR SUPPLY



	<b>MRPL Marketing Terminal Project at Devangonhi, Bangalore</b> <b>Marketing Infrastructure Projects, MRPL</b>				
	<b>Part – C</b>	<b>PACKAGE</b> <b>SCOPE OF WORK</b>	Tender No :		3200000495
	<b>Section – C-1</b>		Document No:		20005-GEN-S-SOW-2015
<b>Subsection – -</b>	Rev :		1		

19.9.1.1. Two OFCs shall be laid along with the 3 Nos. of proposed 14" pipelines MS, HSD and ATF products. For details refer Clause 20.2.4 of this document.



## 19.9.2. INSTALLATION

19.9.2.1. CONTRACTOR shall carry-out installation of two runs of Optic fibre Cable by laying of the two OFC cables in the trench along with proposed 3 Nos. of 14" pipelines. Cable shall run in the cable trench along with proposed 3 nos. of 14" buried Pipelines from Manifold at PMHB facility to PLT manifold at MRPL marketing terminal control panel.



19.9.2.2. Carrying out trenching/ dredging & backfilling and all other associated works for installation of Optic Fibre cable.

19.9.2.3. CONTRACTOR shall ensure that during the installation activities the bending radius of the OFCs will always be greater than the minimum bending radius specified by the OFC manufacturer.

19.9.2.4. Refer to the Interface matrix attached in this document.

## 19.10. INSULATING JOINTS

19.10.1. A monolithic insulating joint is needed for electrical isolation of over ground portion of the pipeline from buried portion. Insulating joints shall be monolithic type. Insulating joints shall be installed in above ground portion of the pipeline, immediately after the buried / aboveground transition at the tie-in stations.

19.10.2. Pipeline insulating joints shall be suitable for use in pipeline transporting MS, HSD and ATF and should be designed in accordance with ASME Section VIII Div. I and welding in accordance with ASME B31.4 and API 1104/ASME Section IX. Insulating joint end pup piece shall have same wall thickness and shall be of equivalent grade and material as connecting pipeline.

19.10.3. The temperature and pressure range of insulating joint shall be in accordance with the indicated values on the relevant pipeline design condition. Wherever pressure / temperature transmitters are used on cathodically protected pipeline the same shall be electrically isolated by providing insulating fittings / flanges.

## 19.11. OTHER REQUIREMENTS



19.11.1. The CONTRACTOR is cautioned to exercise extreme care and take necessary precautions to prevent damage to the existing pipeline(s), facilities, electrical and other cables etc. during execution of works. CONTRACTOR at all times shall ensure that all necessary permissions / clearances are obtained and are up-to date as required during survey, fabrication, construction, installation, testing, pre-commissioning and commissioning and other phases of work.

## 19.12. TIE-IN REQUIREMENTS

19.12.1. Following type of tie-in connections are envisaged under the scope of CONTRACTOR to make the entire system ready for pre commissioning and commissioning activities.

- i. Welded tie-ins at U/G and A/G pipeline (near both existing PMHBL manifold and proposed MRPL PLT manifold) for proposed 3 Nos. of Pipelines for MS, HSD and ATF products.



	<b>MRPL Marketing Terminal Project at Devangonhi, Bangalore</b> <b>Marketing Infrastructure Projects, MRPL</b>				
	<b>Part – C</b>	<b>PACKAGE</b> <b>SCOPE OF WORK</b>	Tender No :		3200000495
	<b>Section – C-1</b>		Document No:		20005-GEN-S-SOW-2015
<b>Subsection – -</b>	Rev :		1		

- ii. Hook-ups / tie-ins with existing/ proposed facilities near manifolds shall be as per PMC approved P&IDs.

### 19.13. HYDROTESTING



- 19.13.1. Before hydro testing, the pipeline shall be cleaned by flushing, cleaning, gauging, filling and testing procedure which shall be subjected to PMC approval. Test pressure and duration of test shall be as per applicable specification enclosed in Bid Document. Suitable type and doses of corrosion inhibitors shall be added to the hydro test water in accordance with bid specifications. Hydro testing of each pipeline section and associated facilities shall be witnessed by COMPANY.
- 19.13.2. Leaks or faults found during testing operations shall be located and repaired till a successful hydrostatic test of the complete pipeline system is achieved. The CONTRACTOR shall prepare testing procedures and submit the same for PMC/ COMPANY's review & approval.
- 19.13.3. Wherever inline instrumentation elements is present, pipelines shall be hydro tested as required by providing caps / plugs / blinds with stubs of required size.
- 19.13.4. During hydrotest, along the pipeline wherever inline instrumentation hook-ups are present, same shall be provided with stubs and isolation valve of required size.

### 19.14. DESIGN REVIEW

- 19.14.1. The CONTRACTOR shall submit a detailed document schedule indicating clearly the sequence and submission of documents for review/ approval by PMC.
- 19.14.2. CONTRACTOR shall submit analysis reports/ drawings/ procedures etc., as applicable, as per PMC approved document submission schedule, and prior to commencement of any phase of fabrication or installation. The fabrication/ installation work shall begin only after PMC / COMPANY approval has been obtained.
- 19.14.3. Complete Installation engineering for onshore pipelines including trenching, pipeline laying and engineering for procurement performed by the CONTRACTOR shall be subject to review and approval by the PMC.
- 19.14.4. All procedures shall be in compliance to requirements of the Bid package and construction techniques proposed by the CONTRACTOR after getting reviewed and approval from PMC.
- 19.14.5. The report(s) shall contain relevant design calculations / analysis results, interpretation and conclusions drawn from calculations/ analysis, recommendations material specifications, drawings and details of construction equipment, procedures, etc. as applicable. The details presented in the report(s) shall be sufficient to confirm compliance to applicable design codes, standards & practices and Bid Package requirements and to prove the validity of CONTRACTOR's design or proposed construction methods

### 19.15. Following are the Analysis Reports and procedures to be submitted, but not limited to,

- a. Pre-construction surveys
- b. Pipelines laying including welding, NDT & Field Joint Coating
- c. Pipelines trenching and burial

	<b>MRPL Marketing Terminal Project at Devangonhi, Bangalore</b> <b>Marketing Infrastructure Projects, MRPL</b>				
	<b>Part – C</b>	<b>PACKAGE</b> <b>SCOPE OF WORK</b>	Tender No :		3200000495
	<b>Section – C-1</b>		Document No:		20005-GEN-S-SOW-2015
<b>Subsection – -</b>	Rev :		1		

- d. Pipeline lifting, and lowering
- e. Cathodic Protection Design Report
- f. Pre-testing of fabricated components
- g. Hydrostatic testing including flushing, cleaning, gauging, filling and pressurizing.
- h. Post test procedures including final tie-ins, setting of valves, cleaning / clearing of worksites etc.
- i. Post-construction/ as-built/ as-laid surveys
- j. Vendor Data Book.
- k. All purchase documents such as purchase requisition, material inspection and test reports, vendor drawings etc. for all bought-out items individually or as a unit.
- l. Details of pipeline fabrication.
- m. As-built Documentation Procedures duly supported but not limited to with calculations/ analysis, as required, to confirm the adequacy of proposed equipment and installation methodology, for the above activities.

#### 19.16. Miscellaneous Documents

- a. Pipelines operation & maintenance manual
- b. Purchase Specifications related to material and equipment
- c. All material testing and inspection reports duly authenticated by independent third party inspection agency.
- d. As-built dossier including as-built / as-laid drawings, pipe book, field inspection and test reports etc.

#### 19.17. AS-BUILT DOCUMENT



- 19.17.1. On completion of all works, the CONTRACTOR shall prepare As-built drawings / reports for pipeline system as specified in Scope of Work. CONTRACTOR shall, as a minimum, provide documents in an As-built dossier. CONTRACTOR to prepare the As-built dossier for PMC review and approval.

#### 19.18. CLEAN-UP

- 19.18.1. Any stakes or temporary obstructions placed along the pipeline right-of-way on land, shall be removed and workspaces cleaned of all scrap and debris and restored to their original condition.
- 19.18.2. CONTRACTOR shall also remove all surplus materials from the workspaces after getting approval from PMC / MRPL.

#### 19.19. CONSTRUCTION



- 19.19.1. All construction works shall be carried out as per “Approved for Construction” drawings, procedures, specifications and applicable codes and standards. Any changes at site shall also need prior approval from the PMC / MRPL and revision of drawings.
- 19.19.2. CONTRACTOR shall assist PMC / MRPL in obtaining the clearances, no objection certificates (NOC) for laying pipeline from concerned authorities. CONTRACTOR shall obtain permits/clearance from concerned authorities before actual commencement of the job at site including preparation and establishment of safety procedures for laying pipeline.

	<b>MRPL Marketing Terminal Project at Devangonhi, Bangalore</b> <b>Marketing Infrastructure Projects, MRPL</b>			
	<b>Part – C</b>	<b>PACKAGE</b> <b>SCOPE OF WORK</b>	Tender No : 3200000495	
	<b>Section – C-1</b>		Document No: 20005-GEN-S-SOW-2015	
<b>Subsection – -</b>	Rev : 1			

- 19.19.3. Immediately after award of individual work, CONTRACTOR shall make a visit to the route to establish the route and familiarize with the working conditions so as to plan for deployment of man and machinery.
- 19.19.4. Some portion of the proposed 3 Nos. of 14" Pipelines shall be laid inside the PMHBL ROU and contractor shall consider the new ROU for the remaining portion of the proposed 3 Nos. of Pipelines laying upto MRPL PLT. Contractor shall take necessary approvals from PMHBL for the laying of proposed 3 Nos. of Pipelines in their restricted ROU. All the approval and related documents shall be issued to PMC / MRPL for approval. Excavated trench & pits in area near traffic and other areas of movement, shall not be left open without barricading. CONTRACTOR shall consider all these eventualities while bidding.
- 19.19.5. CONTRACTOR may plan to work in the Night shift to avoid traffic while crossing roads & utilities. But CONTRACTOR has to plan and take approval from PMC / MRPL and Concerned Authorities before start of construction. CONTRACTOR to arrange all lighting and safety precaution for the same.
- 19.19.6. In some areas if mechanized excavation is found to be not possible, CONTRACTOR shall have to do manual Excavation. CONTRACTOR shall consider all these eventualities while Bidding.
- 19.19.7. Providing schedules, progress reporting, organization chart at construction site, quality assurance plan and developing quality control procedures, as per requirements of the bid package.
- 19.19.8. CONTRACTOR shall be responsible for claims if any arising out of damage/ obstruction to public utilities like OFC lines of DOT, water pipelines etc. where the claims will cover the restoration costs as well as loss of revenue due to down time.
- 19.19.9. Coordination and supervising the work of sub-Contractors. Transportation of appropriate materials to worksite, intermediate storage points, maintaining and operating an adequate material control procedure at worksite.
- 19.19.10. CONTRACTOR shall depute independent third party inspector for carrying out radiographic inspection and interpretation of radiograph of welds. Third party inspector shall be approved by PMC / MRPL.
- 19.19.11. Provide, maintain and operate all temporary facilities required for the construction related works and remove after completion of work.
- 19.19.12. Hook up/tie-in of pipeline and piping system with terminal facilities.
- 19.19.13. All works related to testing, dewatering, swabbing, pre-commissioning and commissioning of the work tendered.
- 19.19.14. Idle time preservation of pipeline as provided in the bid specification.



## 19.20. PIPELINE LAYING WORKS

- 19.20.1. Loading, transportation, unloading, handling, stacking, storing at workshop/work site of all materials other than corrosion coated and bare line pipes that shall be used for the construction of pipeline
- 19.20.2. Carrying out all additional topographic, Geo-technical survey and/or soil investigations required for local detours, crossings and elsewhere during execution including preparing plan and profile drawings as directed by PMC / OWNER.
- 19.20.3. Mobilizing and providing all equipment, manpower (skilled and unskilled), consumables and other resources etc. as required for the execution of complete work.
- 19.20.4. Obtaining all necessary approvals from concerned local authorities having jurisdiction for performing the work including shifting/ relocation and restoration of telephone/ electrical poles and underground pipes and other crossings & utilities etc., as required by local authorities and as directed by PMC / MRPL.

	<b>MRPL Marketing Terminal Project at Devangonhi, Bangalore</b> <b>Marketing Infrastructure Projects, MRPL</b>				
	<b>Part – C</b>	<b>PACKAGE</b> <b>SCOPE OF WORK</b>	Tender No :		3200000495
	<b>Section – C-1</b>		Document No:		20005-GEN-S-SOW-2015
<b>Subsection – -</b>	Rev :		1		

- 19.20.5. Staking, clearing, grading, fencing of Right of Use as required, trenching to all depths in all types of soils including soft/hard rock, by special techniques, chiseling or otherwise cutting etc. as per relevant standards, drawings, specifications etc., transportation of coated pipes to ROU along the route, stringing, aligning, bending, welding, NDT including radiographic inspection, field weld joint coating, sand padding including supply of sand/ soft soil, laying and lowering of the pipeline, back filling including supply of select backfill wherever required, slope breakers as required in slope areas where slope is more than 1 in 10, clean-up, flushing, gauging, hydrostatic testing with the quantity of inhibitor as required, dewatering with the addition of approved chemicals to neutralize the effect of inhibitor added, at required dosage, swabbing, pre-commissioning and all associated works for complete pipeline system as per relevant specifications, standards and approved drawings.  
Thorough internal cleaning of all pipes to remove debris, shots, grit etc. to the satisfaction of PMC.
- 19.20.6. Installation of all in-line/ on-line instruments, valves, insulating joints, appurtenances, etc. if any.
- 19.20.7. Welding of all tie-in joints including tie-in joints and bends on either side of crossings / with adjoining pipeline / other facilities as required.
- 19.20.8. Field weld joint coating shall be by heat shrink sleeve of approved make.
- 19.20.9. Supply and installation of all types of pipeline markers including their painting suitable for and Normal corrosive environment as specified in Standard Specification and all associated civil works. Location of markers shall be as per specification/ standards and as directed by PMC / MRPL.
- 19.20.10. Deleted.
- 19.20.11. Sand/ soft soil padding around pipe wherever required in areas where trenching has been done in pebble / murrum / rock. The thickness of sand / soft soil padding at the bottom of pipe shall be 150mm in these areas. The pipeline trench shall not be filled with gravel & large stones or boulders. Extra digging of trench shall be carried out to comply with above requirements & to provide minimum 1.0 M cover over pipeline.
- 19.20.12. Corrosion coating of long radius bends by heat shrink sleeve as per specification. CONTRACTOR to use these bend judiciously. CONTRACTOR to fabricate and use cold field bend in balance turning points of the route.
- 19.20.13. All incidental and associated works and any other works not specifically listed herein but are required to be carried out to complete entire work related to pipelines and the associated facilities and making the entire pipeline system ready for operation.
- 19.20.14. Wherever the pipeline Right-of-Use runs alongside roads or any other area with restrictions of some kind, Contractor shall grade only the width of the Right-of-Use necessary for digging the pipeline trench and constructing the pipeline. In the said places Contractor shall carry out the works in such a way that damage resulting from the pipeline construction is kept to a minimum. After laying the pipeline, backfilling shall be immediately performed and all the area connected with the works shall be temporarily restored. Throughout the period of execution of such works, Contractor shall provide and use warning signs, traffic lights or lanterns, barricades, fencing, watchman, etc. as required by the local authorities having jurisdiction. For all roads, paths, walkways etc., which are open-cut, Contractor shall provide temporary diversions properly constructed to allow the passage of normal traffic with the minimum of inconvenience and interruptions.  
The paving shall be restored to its original condition after the pipeline is installed
- 19.20.15. Pipeline Warning Sign shall identify the existence of the pipeline and display the name of the COMPANY, with an emergency telephone number.



	<b>MRPL Marketing Terminal Project at Devangonhi, Bangalore</b> <b>Marketing Infrastructure Projects, MRPL</b>					
	<b>Part – C</b>	<b>PACKAGE</b> <b>SCOPE OF WORK</b>			Tender No :	3200000495
	<b>Section – C-1</b>				Document No:	20005-GEN-S-SOW-2015
<b>Subsection – -</b>	Rev :		1			

### 19.21. RESTRICTED R.O.U



- 19.21.1. Most of the areas the Pipeline shall be laid along the road. The ROU shall be restricted in pipeline Route. CONTRACTOR shall consider all these eventualities while bidding. It shall be Contractor's responsibility to make arrangement for any additional land required for fabrication, construction, storage and all other work areas. CONTRACTOR shall carry out construction work within the width as available to him.
- 19.21.2. Damage to any obstruction, temporary/permanent structure, boundary walls etc. shall be repaired and restored by Contractor.
- 19.21.3. The CONTRACTOR must ensure that during laying of the pipeline minimum damage occurs to the land. The land has to be restored to original condition. All construction activities shall be in accordance with the local Government regulations.
- 19.21.4. During pipeline construction, measures shall be adopted in order to minimize the impact of pipeline construction activities on the environment.

### 19.22. ROAD CROSSINGS

- 19.22.1. The method of crossing of roads such as open cut / boring/ trenchless technology shall be firmed up by CONTRACTOR in consultation with concerned authorities and PMC. The CONTRACTOR shall also take due care to identify and take due precautions so as not to disturb or damage the utilities like cables, water lines and other structures.
- 19.22.2. Necessary clearances and permits from concerned authorities/departments like PWD/CPWD etc. shall be taken before starting the job.
- 19.22.3. After laying the pipeline in a road crossing by open cut method, the CONTRACTOR shall completely restore the road to its original condition.
- 19.22.4. While laying the pipeline in road crossings by open cut method the CONTRACTOR should ensure that the traffic is not stopped during the execution of work. This may be done by cutting half of the road at a time so as to enable the traffic to pass on the remaining half of the road. Alternatively, the CONTRACTOR can provide diversion roads to maintain the flow of traffic.
- 19.22.5. The CONTRACTOR shall provide proper caution boards during day time and danger lights during night time when the cutting operation of the road is going on.
- 19.22.6. If required, for cased crossings, the pipeline should be taken through the casing pipeline, the top of which should be at least 1.2 meters below the road top as specified or as per the requirements of the local authorities, whichever is higher.

### 19.23. CONTRACTOR'S RESPONSIBILITIES

- 19.23.1. Contractors responsibilities, besides the scope of work to be performed by CONTRACTOR defined earlier shall also include the following.
  - a. Entire design and detailed engineering including drawings and installation procedures, engineering for procurement & fabrication, engineering for installation including drawings, QA/QC procedures, etc. performed by the CONTRACTOR for complete pipeline system shall be reviewed and approved by PMC / MRPL. CONTRACTOR shall submit six sets of design/detailed engineering documents, drawings, procedures for PMC / MRPL's review and approval. All works shall be executed based on approved documents only.

	<b>MRPL Marketing Terminal Project at Devangonhi, Bangalore</b> <b>Marketing Infrastructure Projects, MRPL</b>				
	<b>Part – C</b>	<b>PACKAGE</b> <b>SCOPE OF WORK</b>	Tender No :		3200000495
	<b>Section – C-1</b>		Document No:		20005-GEN-S-SOW-2015
<b>Subsection – -</b>	Rev :		1		



- b. Provide office and office support services/facilities for PMC & MRPL's Personnel at Contractor's design office for design review and approval of documents as per the requirement of the bid package.
- c. Review and approval of Contractor's entire work(s) by PMC shall in no way relieve the CONTRACTOR of his sole responsibility for safe and efficient design, engineering, installation and subsequent operation of pipeline system.

#### **19.24. Pre-commissioning / commissioning of entire pipeline / piping system.**

- 19.24.1. Preparing and furnishing calculation books, pipe books, final purchase specifications, Vendor's data books (including Guarantees), fabrication and construction drawings, all survey reports, inspection and testing reports, as-built records for all phases of work.
- 19.24.2. The CONTRACTOR is cautioned to exercise extreme care and take necessary precautions to prevent damage to the existing pipeline(s), facilities, electrical and other cables during execution of the entire works. Restoration / reconstruction of all structures / facilities affected during pipeline construction shall be carried out by Contractor.
- 19.24.3. CONTRACTOR to ensure water supplies across the cultivation fields up till construction is completed by providing suitable water supply arrangements similar to the existing one or of higher spec, wherever CONTRACTOR comes across water lines/open channels/drains in the fields used for cultivation.
- 19.24.4. Any claims arising out of noncompliance to the above requirements, as granted by competent authorities shall be to Contractor's account.
- 19.24.5. CONTRACTOR shall carry out all testing and inspection of materials, equipment etc. in independent testing institutions, laboratories, if so desired by PMC.
- 19.24.6. Disposal and treatment of treated hydro-testing water, excavated materials, and surplus materials etc. as per local authority's requirements. Necessary permissions shall be obtained by the contractor.
- 19.24.7. Any other work not specifically listed but required for successful completion of entire pipeline system.

#### **19.25. AS BUILT DOCUMENT**

- 19.25.1. On successful completion of hydrostatic testing, the CONTRACTOR shall prepare As-Built drawings / reports for entire pipeline/piping system as specified in scope of work. All following "As-Built" drawings / reports shall be submitted as per MRPL documentation procedure.
- 19.25.2. MAIN PIPELINE
  - a. As laid alignment sheets and crossing drawings / details
  - b. As built crossing details, as applicable
  - c. All Inspection, Testing and NDT records. Radiographs / UT of all weld joints packed kilometer wise in separate card board boxes in one set
  - d. Pipe and calculation books / records

	<b>MRPL Marketing Terminal Project at Devangonhi, Bangalore</b> <b>Marketing Infrastructure Projects, MRPL</b>				
	<b>Part – C</b>	<b>PACKAGE</b> <b>SCOPE OF WORK</b>	Tender No :		3200000495
	<b>Section – C-1</b>		Document No:		20005-GEN-S-SOW-2015
<b>Subsection – -</b>	Rev :		1		



- e. All WPS and WQT
  - f. All NOC from authority
  - g. All inspection & testing documents
  - h. All purchase specification & procurement documents
- 19.25.3. DISPATCH AND RECEIVING STATIONS

- a. All piping GAD and supports at terminals
- b. All P&ID, layout, Isometric drawings
- c. Installation and testing reports
- d. All Test reports, IRN's for procured materials
- e. All purchase specification ad procurement documents

## 19.26. DOCUMENTS, SPECIFICATION, STANDARDS & DRAWINGS

- 19.26.1. PMC will furnish tentative pipeline route along with the tender. CONTRACTOR shall prepare all necessary drawings, documents, calculations, design reports and submit the same for PMC approval. CONTRACTOR shall submit generated drawings in Auto CAD format. Any construction shall not be carried out without proper construction drawings duly approved by PMC.
- 19.26.2. CONTRACTOR shall generate deliverables given below as a minimum during detailed engineering phase:
- a. Mechanical design report
  - b. Stress analysis report
  - c. Upheaval buckling calculations
  - d. Pipeline alignment drawings
  - e. Standard drawings
  - f. Crossing drawings
  - g. Specifications/Datasheets
- 19.26.3. After completion of construction & commissioning of Terminal, CONTRACTOR shall issue "As-built dossier" as final submission.
- 19.26.4. Any construction done by the CONTRACTOR without duly approved drawings shall be wholly at risk and cost to Contractor. CONTRACTOR shall also submit soft copy of pipe book in excel along with hard copy. Soft copy of all as-built drawings shall be submitted in AutoCAD. Videography / photograph of all major activities / milestone achieved shall also be arranged and submitted by the contractor. CONTRACTOR shall submit final documentation as per requirements stated elsewhere in the Tender documents.

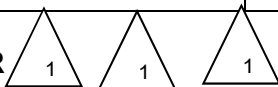

	<b>MRPL Marketing Terminal Project at Devangonhi, Bangalore</b> <b>Marketing Infrastructure Projects, MRPL</b>				
	Part – C	<b>PACKAGE SCOPE OF WORK</b>	Tender No :		3200000495
	Section – C-1		Document No:		20005-GEN-S-SOW-2015
Subsection – -	Rev :		1		

**16.2.4.10. BULK AIR ELIMINATOR**

**8 nos.** of bulk air eliminator shall be provided as per below table:

Sl. No.	Description	Bulk Eliminator - 1A	Bulk Eliminator - 1B	Bulk Eliminator - 1C	Bulk Eliminator -2	Bulk Eliminator-3	Bulk Eliminator -4	Bulk Eliminator -5	Bulk Eliminator -6
1	Operating Flow, m3/hr	585	585	585	360	720	360	30	30
2	Design Flow, m3/hr	1050	1050	1050	360	1050	360	60	60
3	Operating Pressure, kg/cm <sup>2</sup>	4 to 8	4 to 8	4 to 8	5	5	5	5	5
4	Operating Temp, °C	5 to 45	5 to 45	5 to 45	5 to 45	5 to 45	5 to 45	5 to 45	5 to 45
5	Design Pressure, kg/cm <sup>2</sup>	10	10	10	10	10	10	10	10
6	Design Temperature, °C	65	65	65	65	65	65	65	65
7	Service Fluid	MS/PC A/PCK	HSD/P CA/PC K	ATF/P CA/PC K	MS	HSD	ATF	Ethanol	Bio-diesel
8	Inlet / Outlet Connections	14"	14"	14"	10"	16"	10"	3"	3"

16.2.4.10.1. Bulk air eliminator shall be designed as per ASME Sec. VIII Div. 1.

16.2.4.10.2. MOC of bulk air eliminator shall be similar to piping MOC on which they are mounted.

16.2.4.10.3. Relief valve shall be provided on the air eliminator.

16.2.4.10.4. Bulk air eliminator shall comply with requirements of Design Basis for Static Equipment.

**16.2.4.11. MATERIAL HANDLING FACILITIES/ EQUIPMENT**

16.2.4.11.1. Lifting facilities shall be provided in the terminal for maintenance and facilitate removal, handling, shifting and lifting of maintainable components.

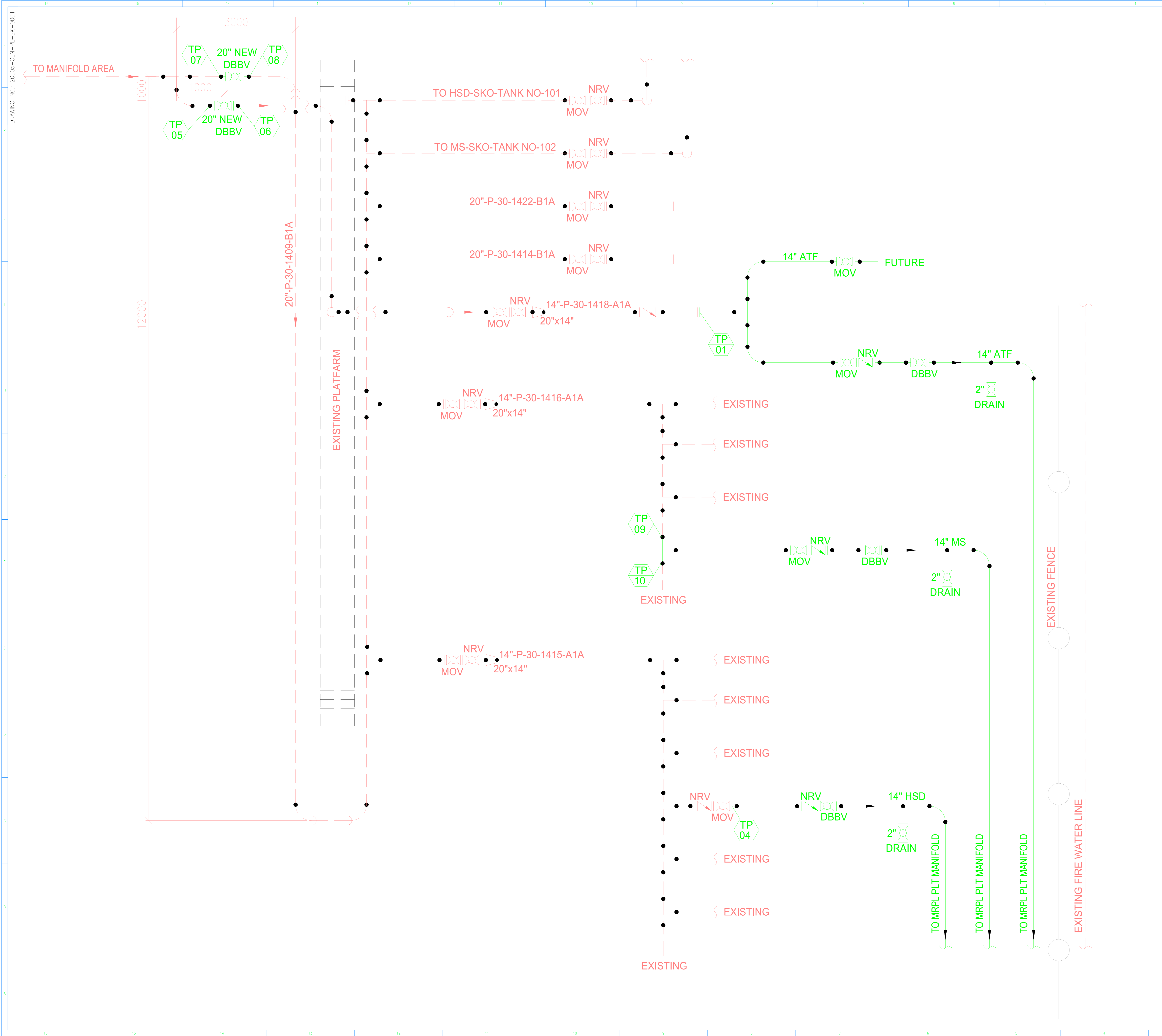

NOTES

1. All dimensions are in mm unless noted otherwise.
2. All the dimensions and tie-in points to be reverified by the LSTK Contractor during site engineering survey conducted by him for detail Engineering.

LEGEND:

- Existing
- New
- TP Tie-in Point
- Fence

ALL RIGHTS RESERVED. NO PART OF THIS DRAWING MAY BE REPRODUCED / STORED IN RETRIEVAL SYSTEM OR TRANSMITTED IN ANY FORM OR BY ANY MEANS ELECTRONIC, MECHANICAL, PHOTOCOPIING, XEROXING OR OTHERWISE WITHOUT PRIOR PERMISSION FROM NAUVATA ENGINEERING LTD./MRPL

REV.	DATE	DESCRIPTION	VD/BK	SDK	SDK	MRPL
0	28-APR-21	ISSUED FOR BIDDER INFORMATION				

CLIENT:  
**MANGALORE REFINERY AND PETROCHEMICALS LIMITED**  
 (A subsidiary of Oil & Natural Gas Corpn. Ltd - ONGC)

PROJECT:  
**CONSTRUCTION OF MARKETING TERMINAL PROJECT AT DEVANGONTHI, BANGALORE.**

PROJECT MANAGEMENT CONSULTANT:  
**NAUVATA ENGINEERING PVT. LTD.**

DRAWING TITLE: **SCHEMATIC OF MRPL WORKS IN PMHBL MANIFOLD AREA**

CLIENT TENDER No:	DRAWING No: 20005-GEN-PL-SK-0001	SHT NO. 1 OF 2	REV 0	SCALE: NTS
-------------------	-------------------------------------	-------------------	----------	---------------

**SCHEMATIC SKETCH OF 14 INCH PIPELINE FROM MANIFOLD (AT PMHB TERMINAL) TO PLT (AT MRPL TERMINAL)**

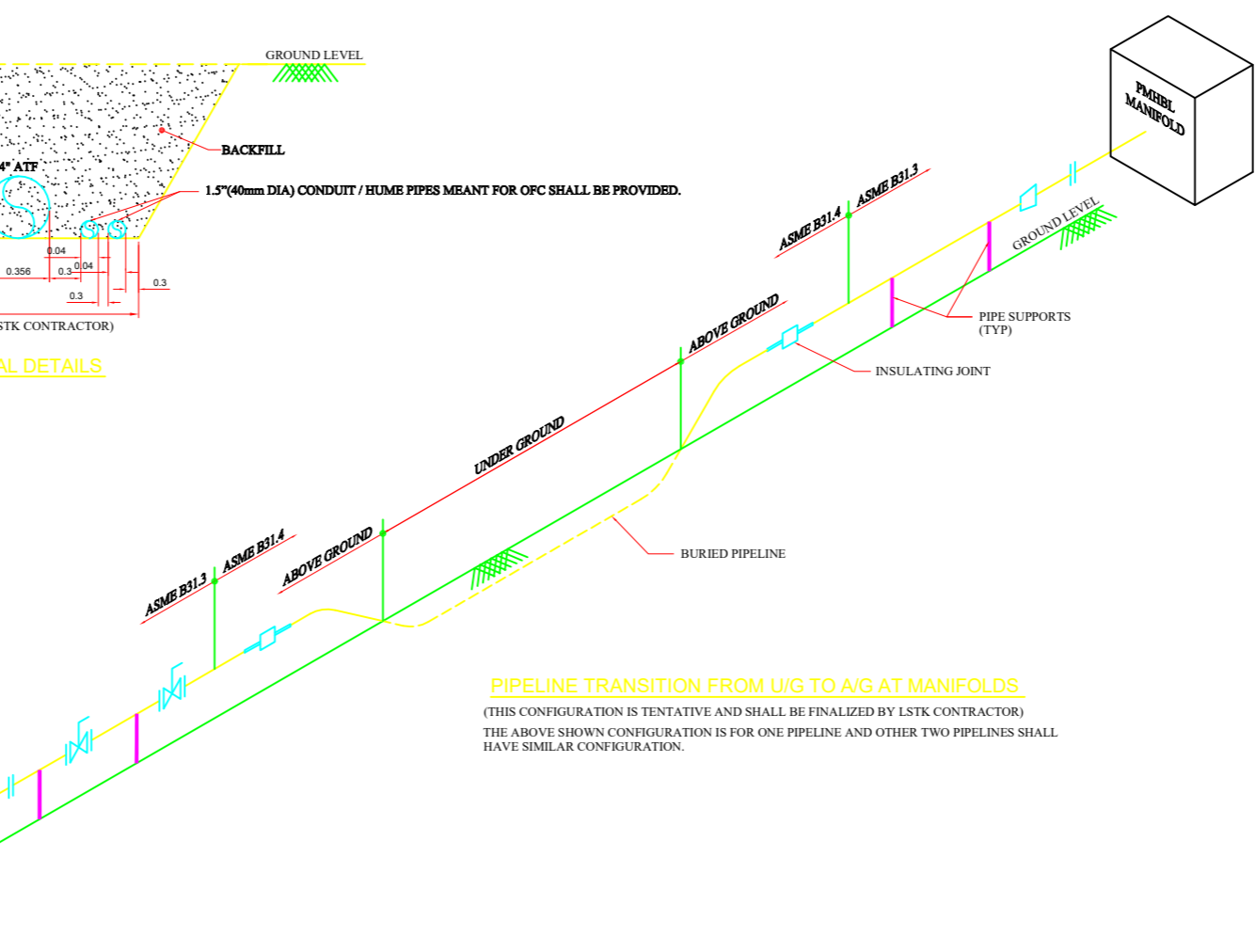
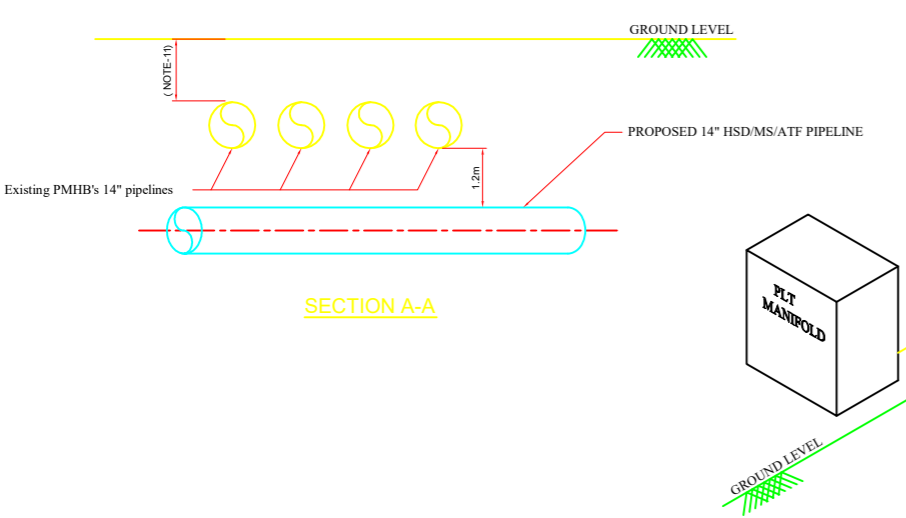
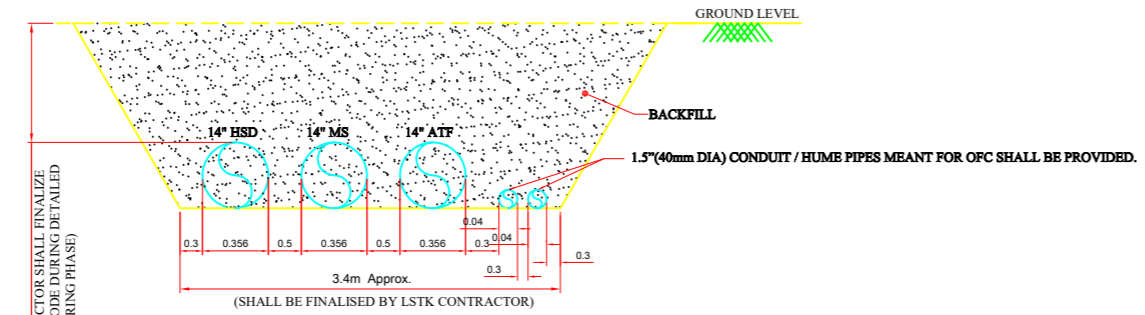
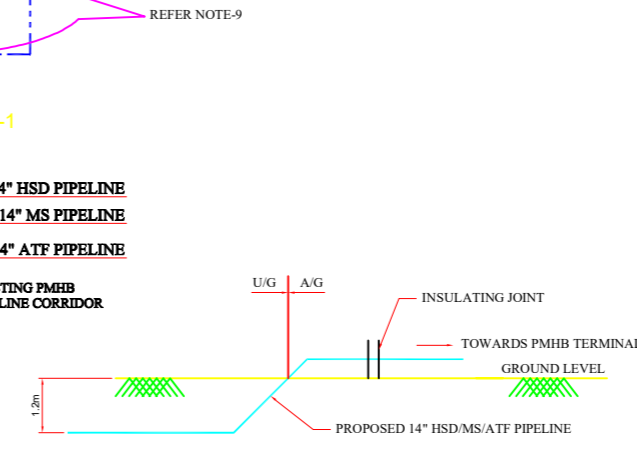
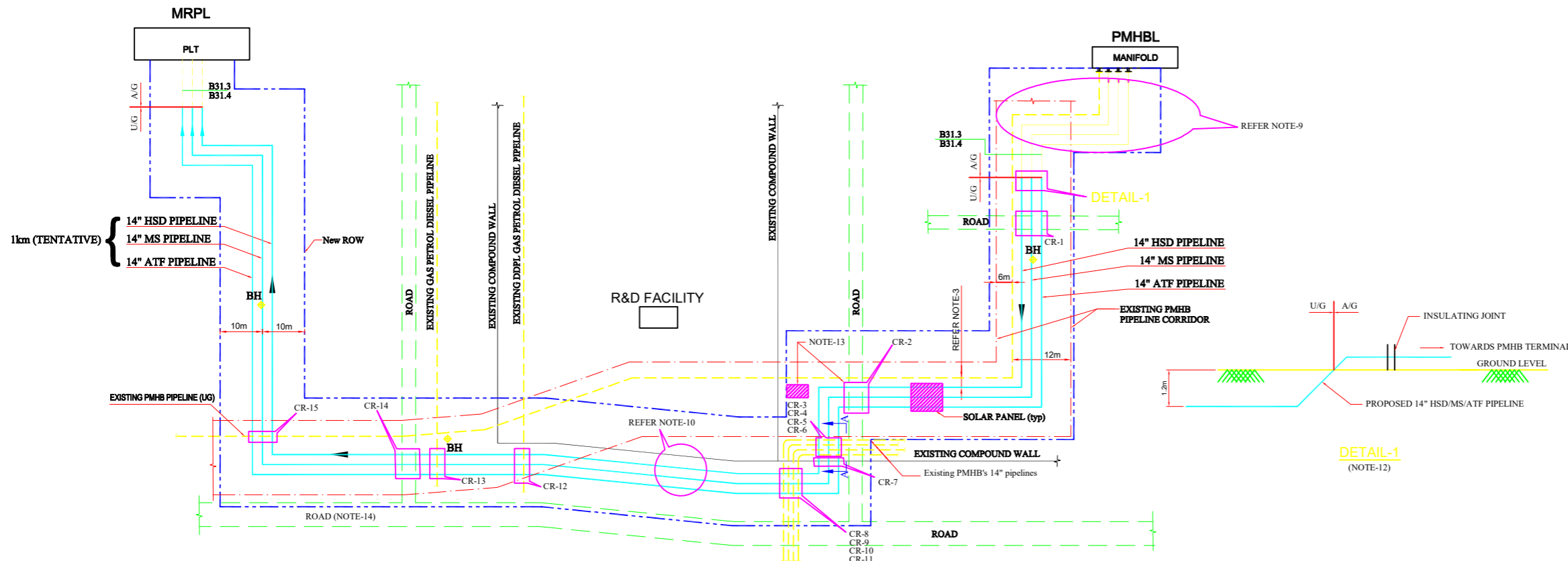

**PIPELINE TRANSITION FROM U/G TO A/G AT MANIFOLDS**  
 (THIS CONFIGURATION IS TENTATIVE AND SHALL BE FINALIZED BY LSTK CONTRACTOR)  
 THE ABOVE SHOWN CONFIGURATION IS FOR ONE PIPELINE AND OTHER TWO PIPELINES SHALL HAVE SIMILAR CONFIGURATION.

- All dimensions are in meters unless noted otherwise.
- Existing facilities interfering with the Proposed 14" HSD/MS/ATF pipelines shall be reinstated to its original position after laying of pipelines by LSTK contractor.
- LSTK contractor to ensure the Proposed 14" pipelines are laid with clear distance of 3m from existing PMHB pipeline.
- LSTK contractor to ensure the Proposed 14" pipelines are laid to match burial depth of existing PMHB pipeline at crossing locations (CR-12 & CR-13). Crossing shall be designed and engineered by LSTK contractor based on actual survey.
- Pipeline route indicated is tentative, LSTK contractor to finalize the pipeline route during detailed engineering.
- LSTK contractor to obtain prior approval from PMC/MRPL, if increase in Pipelines length and number of crossings occurs during detailed engineering. Contractor should not claim for additional cost and time.
- 3 numbers of borehole data shall be collected along the pipeline route. However borehole locations indicated are tentative and shall be finalised during detailed engineering, by LSTK contractor.
- Wherever usage of 40D bends are not feasible during pipeline laying, 5D bends shall be used.
- Contractor shall firm up configuration of pipelines from PMHBL manifold tie-in point to PMHB pipeline's ROW during detailed engineering phase. Contractor shall obtain necessary approval by PMHB authorities for the same.
- Contractor to consider following for pipeline construction adjacent to HPCL R&D facility:
  - Pipeline shall be laid at a clear distance of 2m from existing compound wall.
  - Contractor shall obtain necessary statutory approvals from authorities.
  - PMC/MRPL will assist in obtaining statutory approvals.
- Burial depth of PMHB's existing pipelines shall be verified and finalized during pre-engineering survey.
- Contractor to firm-up detail including bends during detailed engineering phase.
- Solar Panel shall be removed before laying of pipeline, contractor to ensure the same shall be reinstated in the same position after laying of pipeline, backfilling, cleaning and grading is carried out without any damages for the newly laid pipelines. Also Contractor to ensure clear distance shall be maintained between the trench wall (at FGL) and the road (PMHBL's emergency exit road). So, that road will not be disturbed nor damaged during pipeline laying activity.
- Necessary permissions / approval shall be obtained by the contractor to open cut a bitumen road for laying of pipeline alongside the road. Wherever the pipeline Right Of Use (ROU) runs alongside the road, contractor shall grade only the width of Right of Use necessary for digging the pipeline trench and constructing / laying of pipeline. In the said places contractor shall carry out the works in such a way that the damage resulting from the pipeline construction is kept minimum. The Paving shall be restored to its original condition after the pipeline is installed.

2	06-MAY-21	RE-ISSUED FOR BID	PB	SW	SW
1	12-APR-21	RE-ISSUED FOR BID	PB	SW	SW
0	12-MAR-21	ISSUED FOR BID	PB	SW	SW
REV.	DATE	DESCRIPTION	DRWN	CHKD	APPRO
			NAU		MRPL

CLIENT:  
**MANGALORE REFINERY AND PETROCHEMICALS LIMITED**  
 (A subsidiary of Oil & Natural Gas Corp. Ltd - ONGC)

PROJECT:  
**CONSTRUCTION OF MARKETING TERMINAL PROJECT AT DEVANGONTHI, BANGALORE.**

PROJECT MANAGEMENT CONSULTANT:  
**NAUVATA ENGINEERING PVT. LTD.**

DRAWING TITLE: **SCHEMATIC OF PROPOSED 14 INCH PIPELINE**

CLIENT TENDER No:	DRAWING No:	SHT NO.	REV	SCALE:
	20005-GEN-PL-SK-0001	2 OF 2	2	NTS

ALL RIGHTS RESERVED. NO PART OF THIS DRAWING MAY BE REPRODUCED / STORED IN RETRIEVAL SYSTEM OR TRANSMITTED IN ANY FORM OR BY ANY MEANS ELECTRONIC, MECHANICAL, PHOTOCOPIING, XEROXING OR OTHERWISE WITHOUT PRIOR PERMISSION FROM NAUVATA ENGINEERING LTD./MRPL

DRAWING NO.: 20005-GEN-PL-SK-0001

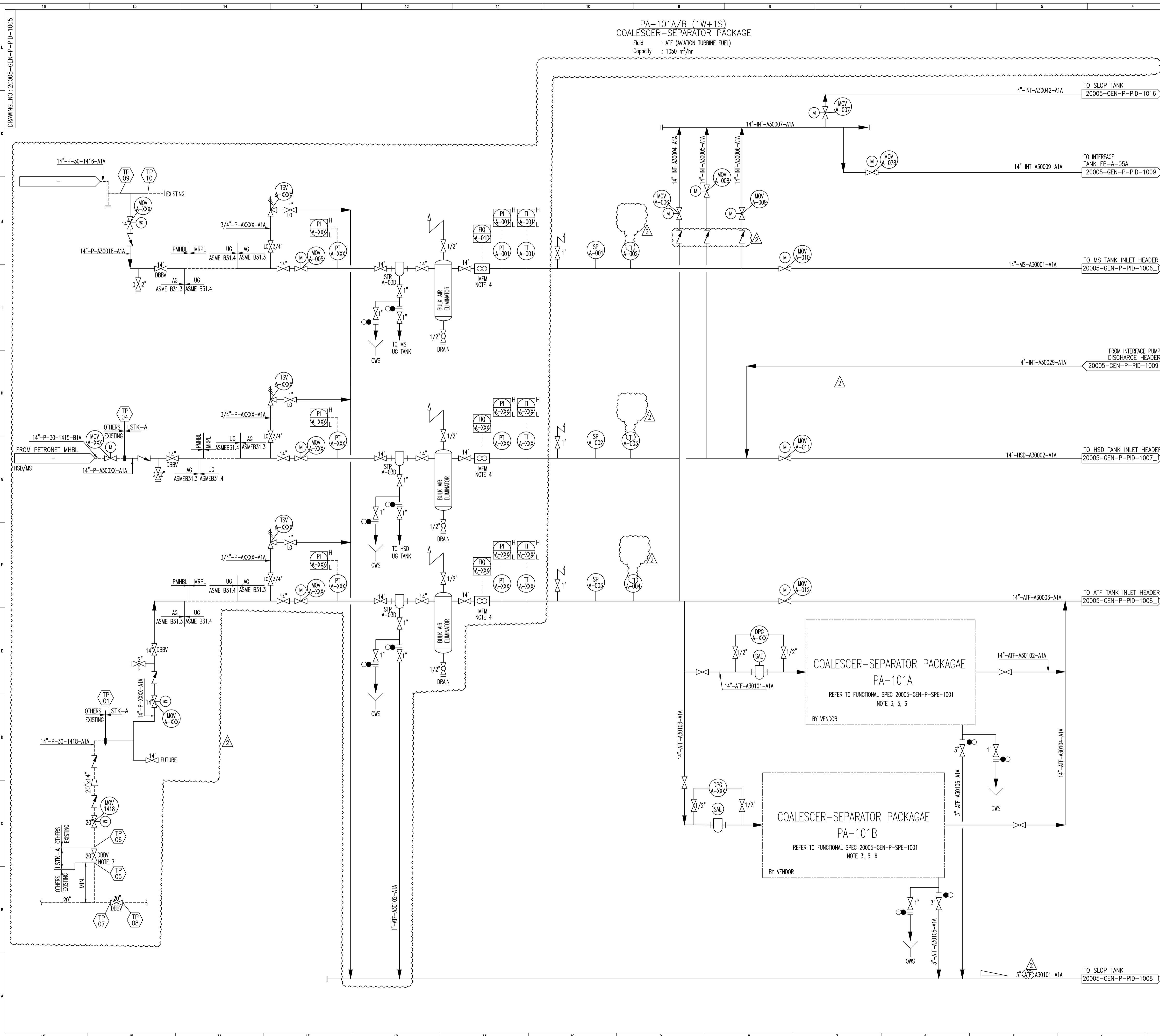

- NOTES**
1. ALL SIZES ARE IN INCH. UNLESS OTHERWISE SPECIFIED.
  2. P & ID IS BASED ON DESIGN BASIS FOR DEVANGONTHI.
  3. DETAILED DESIGN/ENGINEERING OF COALESCE-SEPARATOR BY LSTK CONTRACTOR/PACKAGE VENDOR DURING DETAILED ENGINEERING.
  4. FLOW MEASUREMENT SHALL BE PRESSURE & TEMPERATURE COMPENSATED.
  5. COALESCE-FILTER PACKAGE UNIT SHALL BE DESIGNED AS PER API-1581 CATEGORY (C) TYPE (S) AND SHALL MEET DGCA REQUIREMENT.
  6. THE COALESCE SEPARATOR PACKAGE SHALL HAVE INBUILT MICRON FILTER, IF NOT LSTK CONTRACTOR SHALL PROVIDE THE MICRON FOR EACH COALESCE-SEPARATOR PACKAGE SEPARATELY.
  7. NEW 20° DBBV SHALL BE PROVIDED IN THE EXISTING LINES BY CUT AND WELDED (HOT JOINT) INSIDE THE PMHBL UNIT.

ALL INSTRUMENTS AND CONTROLS SHOWN IN THIS P&ID, (EXCLUDING INSTRUMENTS AND CONTROLS RELATED TO PACKAGE UNITS AND INLINE INSTRUMENTS LIKE MOV, DBBV, PSV/TSV) ARE IN LSTK-C CONTRACTOR SCOPE.

ALL SAMPLING SYSTEMS SHALL BE IN LSTK-A CONTRACTOR SCOPE.

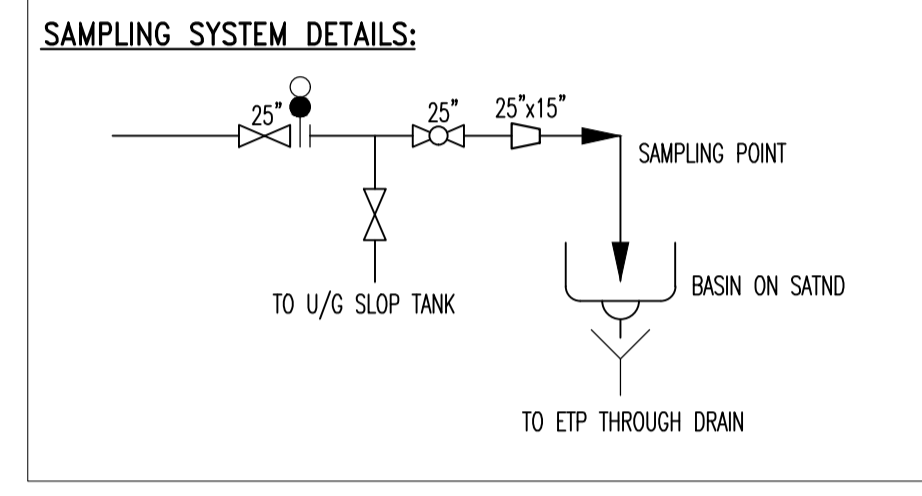

- LEGENDS.**
- CHV
  - GATE VALVE
  - NEEDLE VALVE
  - BASKET STRAINER
  - BUTTERFLY VALVE
  - BALL VALVE
  - AUTO RECIRCULATION VALVE
  - DOUBLE BLOCK BLEED VALVE
  - OPEN DRAIN FUNNEL
  - FIELD INSTRUMENTS INDIVIDUALLY SPECIFIED
  - BLIND FLANGE
  - MOV (GATE VALVE)
  - MOTOR
  - INTERLOCK
  - MASS FLOW METER

SL.NO	REV.	TITLE
<b>REFERENCE DRAWINGS</b>		

REV.	DATE	DESCRIPTION	DRWN	CHKD	APPRD	MRPL
2	07-MAY-21	RE-ISSUED FOR BID	SPS	SK/PM	NSN	
1	02-MAR-21	RE-ISSUED FOR BID	SPS	SK/PM	NSN	
0	12-FEB-21	ISSUED FOR BID	SPS	SK/PM	NSN	
C2	14-DEC-20	RE-ISSUED FOR APPROVAL	SPS	SK/PM	NSN	
C1	08-DEC-20	ISSUED FOR APPROVAL	SPS	SK/PM	NSN	

CLIENT: **MANGALORE REFINERY AND PETROCHEMICALS LIMITED**  
(A subsidiary of Oil & Natural Gas Corpn. Ltd - ONGC)

PROJECT: **CONSTRUCTION OF MARKETING TERMINAL PROJECT AT DEVANGONTHI, BANGALORE.**

PROJECT MANAGEMENT CONSULTANT: **NAUVATA ENGINEERING PVT. LTD.**

DRAWING TITLE: **PIPING AND INSTRUMENTATION DIAGRAM PLT MANIFOLD**

CLIENT TENDER No:	DRAWING No:	SHT NO.	REV	SCALE:
	20005-GEN-P-PID-1005	1 OF 1	2	1:1

ALL RIGHTS RESERVED. NO PART OF THIS DRAWING MAY BE REPRODUCED / STORED IN RETRIEVAL SYSTEM OR TRANSMITTED IN ANY FORM OR BY ANY MEANS ELECTRONIC, MECHANICAL, PHOTOCOPIING, XEROXING OR OTHERWISE WITHOUT PRIOR PERMISSION FROM NAUVATA ENGINEERING LTD./MRPL

DRAWING NO: 20005-GEN-P-PID-1016

GA-A-11A  
SLOP OIL TRANSFER PUMP  
CAPACITY: 30M3/HR  
HEAD: 65 MLC

FB-A-08A  
SLOP TANK  
Fluid : MIXED  
Capacity : 70.0 KL  
Type : U/G Tank

NOTES

1. ALL SIZES ARE IN INCH, UNLESS OTHERWISE SPECIFIED.
2. OIL WATER SEPARATOR SYSTEM WILL HAVE FOLLOWING MINIMUM INDICATION / CONTROL.  
AT LCP- RUN, STOP, FAULT, ALARM.
3. 1 NO. ELECTRIC FEEDER OF 3 -PHASE, 415V, 50HZ SUPPLY SHALL BE PROVIDED AT PCB LOCALLY MOUNTED FOR OWS AND PUMP.
4. IN TANK FARM AREA THE PRODUCT DRAIN FROM DDBVS WILL BE TAKEN TO OWS THROUGH DYKE DRAIN PIT.
5. ALL OWS PIPE LINE SHALL BE UNDER GROUND WITH WRAPPING COATING AGAINST SOIL CORROSION & GENERALLY IT SHOULD BE MINIMUM 1 METER BELOW GROUND LEVEL.
6. OWS PIPE LINE MUST HAVE A SLOPE TOWARDS OWS IN THE RATIO OF 1:400 TO FACILITATE COMPLETE DRAINAGE.
7. OPEN DRAINS FROM PUMP, LINES, DRUMS, ETC.
8. LSTK CONTRACTOR TO DEVELOP DETAILED NETWORK DRAWING BOTH OPEN DRAINS AND CLOSED DRAINS DURING DETAILED ENGINEERING.
9. ALL THE DYKE DRAIN VALVES SHALL BE FITTED WITH A PROXIMITY SWITCH OR SENSOR FOR INDICATION OF THE POSITION OF THE VALVE.
10. MICRO/CARTRIDGE FILTER (10 MICRON) WITH NECESSARY INSTRUMENTS AND SAFETY VALVE SHALL BE PROVIDED.

DESIGN AND CONSTRUCTION OF ALL VALVE PITS, TLF GANTRY SHEDS, OWS UNIT & UG PIT FOR SLOP TANK ARE IN LSTK-B CONTRACTOR SCOPE.

ALL INSTRUMENTS AND CONTROL SHOWN IN THIS P&ID, (EXCLUDING THE INSTRUMENTS & CONTROLS RELATED TO PACAKGE UNITS )ARE IN LSTK-C CONTRACTOR.

ALL SAMPLING SYSTEMS SHALL BE IN LSTK-A CONTRACTOR SCOPE.

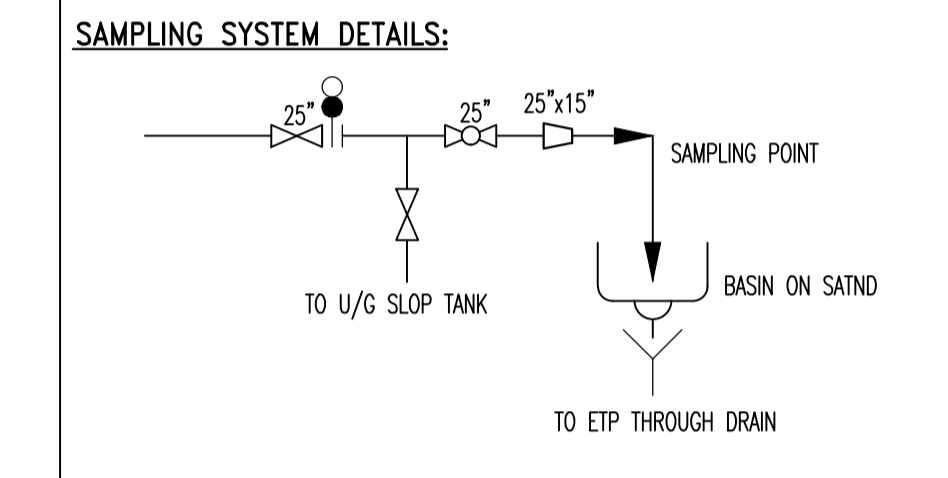

LEGENDS.

- CHV
- GATE VALVE
- NEEDLE VALVE
- BASKET STRAINER
- BUTTERFLY VALVE
- BALL VALVE
- AUTO RECIRCULATION VALVE
- DOUBLE BLOCK BLEED VALVE
- OPEN DRAIN FUNNEL
- FIELD INSTRUMENTS INDIVIDUALLY SPECIFIED
- BLIND FLANGE
- MOV (GATE VALVE)
- MOTOR
- INTERLOCK

SLNO	REV.	TITLE
REFERENCE DRAWINGS		
2	07-MAY-21	RE-ISSUED FOR BID
1	02-MAR-21	RE-ISSUED FOR BID
0	15-02-21	ISSUED FOR BID
C1	18-DEC-20	ISSUED FOR REVIEW/COMMENTS
REV.	DATE	DESCRIPTION
		DRWN   CHKD   APPRD
		NAU

SLNO	DATE	DESCRIPTION	MRPL
2	07-MAY-21	RE-ISSUED FOR BID	SPS SK/PM NSN
1	02-MAR-21	RE-ISSUED FOR BID	SPS SK/PM NSN
0	15-02-21	ISSUED FOR BID	SPS SK/PM NSN
C1	18-DEC-20	ISSUED FOR REVIEW/COMMENTS	SPS SK/PM NSN
REV.	DATE	DESCRIPTION	DRWN   CHKD   APPRD
			NAU

CLIENT:  
**MANGALORE REFINERY AND PETROCHEMICALS LIMITED**  
 (A subsidiary of Oil & Natural Gas Corpn. Ltd - ONGC)

PROJECT:  
**CONSTRUCTION OF MARKETING TERMINAL PROJECT AT DEVANGONTHI, BANGALORE.**

PROJECT MANAGEMENT CONSULTANT:  
**NAUVATA ENGINEERING PVT. LTD.**

DRAWING TITLE:  
**PIPING AND INSTRUMENTATION DIAGRAM OILY WATER SEWER NETWORK & SLOP TANK**

CLIENT TENDER No:	DRAWING No:	SHT NO.	REV	SCALE:
	20005-GEN-P-PID-1016	1 OF 1	2	1:1

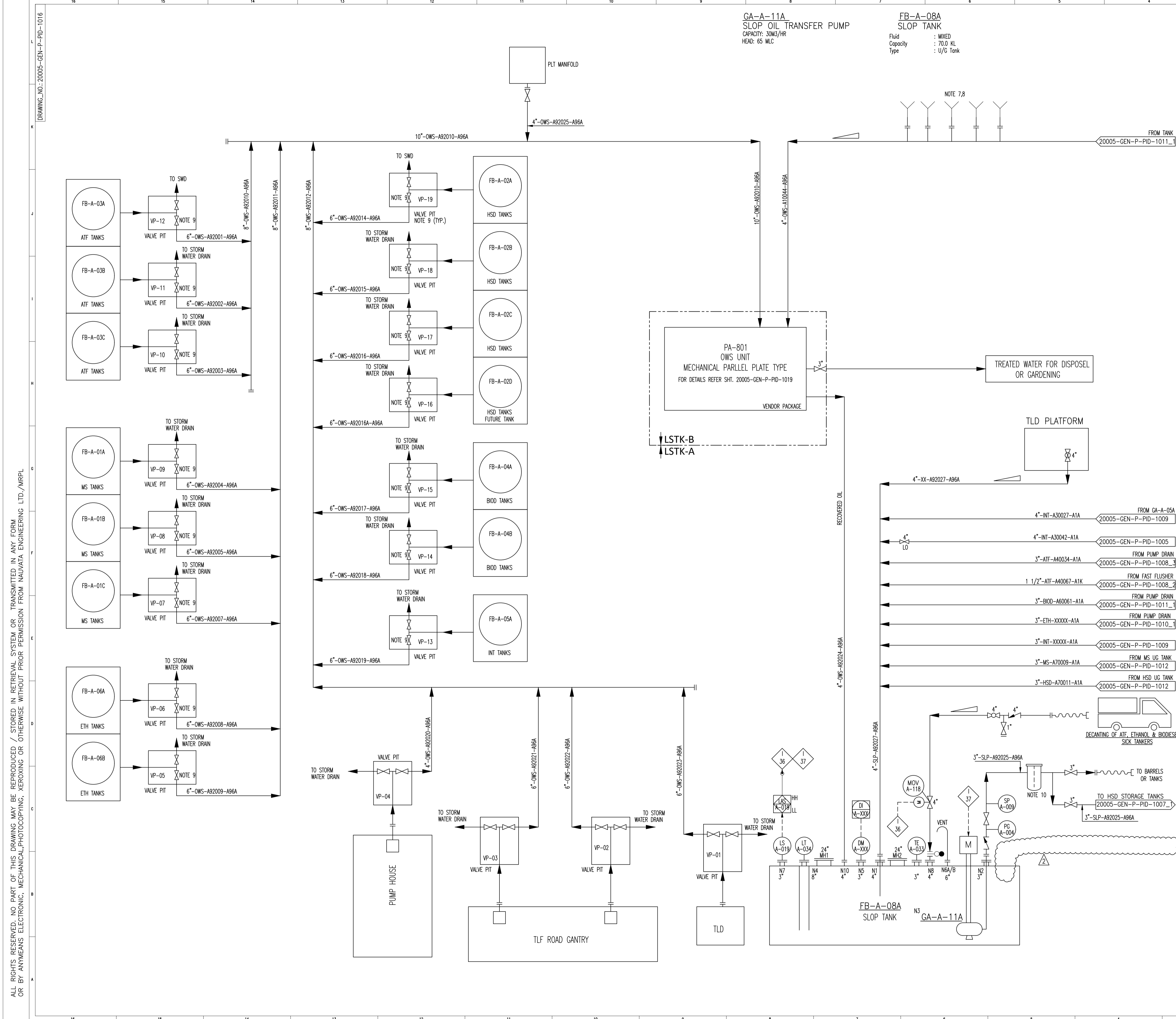

ALL RIGHTS RESERVED. NO PART OF THIS DRAWING MAY BE REPRODUCED / STORED IN RETRIEVAL SYSTEM OR TRANSMITTED IN ANY FORM OR BY ANYMEANS ELECTRONIC, MECHANICAL,PHOTOCOPIING, XEROXING OR OTHERWISE WITHOUT PRIOR PERMISSION FROM NAUVATA ENGINEERING LTD./MRPL

DRAWING NO.: 20005-GEN-L-DW-3001

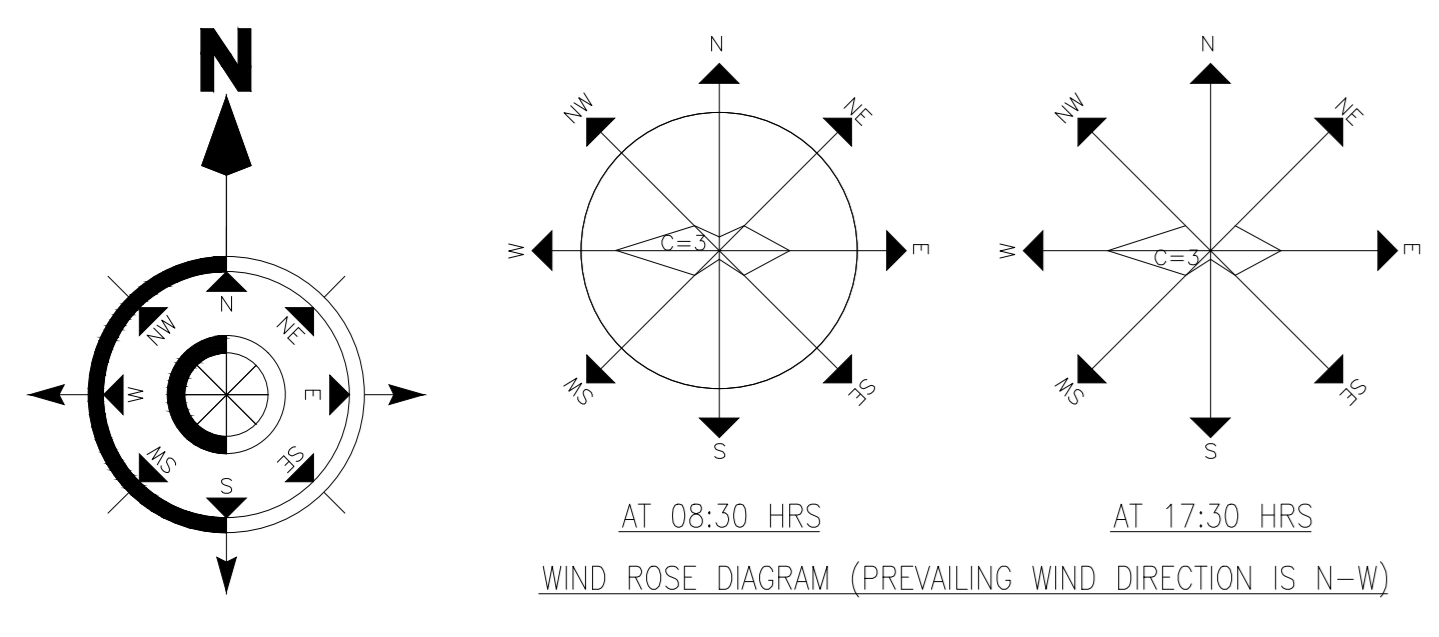

SCHEDULE OF PRODUCT PUMPS			
S.NO.	TAG NO.	PRODUCT	NO. OF PUMPS
1	GA-A-01A/B/C	MS	2(1W+1S)+ 1 FUTURE
2	GA-A-02A/B/C/D	HSD	3(2W+1S)+ 1 FUTURE
3	GA-A-03A/B/C	ATF	2(1W+1S)+ 1 FUTURE
4	GA-A-04A/B/C	BIO-DIESEL	3(2W+1S)
5	GA-A-05A	INTERFACE	1
6	GA-A-06A/B/C	ETHANOL	3(2W+1S)
7	GA-A-07A/B	MS ADDITIVE	2 (1W+1S)
8	GA-A-08A/B	HSD ADDITIVE	2 (1W+1S)
9	GA-A-09A	MS VERTICAL	1
10	GA-A-10A	HSD VERTICAL	1
11	GA-A-11A	SLOP OIL TRANSFER	1
12	GA-A-16A/B	ATF ADDITIVE	2 (1W+1S)
13	GA-A-18	METER CALIBRATION	1
14	GA-A-23A/B	OWS SUMP	2 (1W+1S)
15	GA-A-26A/B	RAW WATER	2 (1W+1S)
16	GA-A-27A/B/C/D	BOREWELL	4 (3W+1S)
17	GA-A-28A/B	POTABLE WATER	2 (1W+1S)
18	GA-A-29	TT CALIBRATION RECYCLE	1
19	GA-A-30A/B	CORROSION INHIBITOR	2 (1W+1S)
20	GA-A-802A/B	FIREWATER TRANSFER	2 (1W+1S)

- NOTES :**
- ALL DIMENSIONS, CO-ORDINATES AND LEVELS ARE IN METERS, UNLESS NOTED OTHERWISE.
  - THIS FACILITIES ARE DESIGNED AS PER OISD 117 / OISD 244.
  - ALL THE FACILITIES DIMENSIONS ARE PRELIMINARY AND TO BE FINALISED DURING LSTK DETAIL ENGINEERING STAGE.
  - FGL OF THE PLANT VARIES FROM 900.00M TO 901.25M.
  - GREEN BELT AREA SHALL BE GRADED SUITABLY TO PROVIDE PROPER SLOPES FOR DRAINAGE TO NEAREST DITCH OR STORM WATER OUTLETS.
  - DYKE WALL HEIGHT SHALL BE 2.0 M & 0.3 M WIDTH.
  - FIRE WALL HEIGHT SHALL BE 800 MM.
  - LOCATION AND DIMENSIONS FOR BESCOM TARIFF METERING YARD IS INDICATIVE ONLY AND SAME SHALL BE UPDATED AS PER VENDOR DATA DURING DETAIL ENGINEERING STAGE.
  - PLOTTING IS INDICATIVE ONLY HOWEVER ANY CHANGES SHALL BE DONE WITH CONSULTATION OF PMC.
  - TENTATIVE LOCATION OF EXISTING MHB PIPELINE INDICATED. LSTK CONTRACTOR TO ASCERTAIN THE EXACT LOCATION OF THE PIPE LINE DURING DETAIL ENGINEERING, CONSIDERING CLEARANCE OF 8M TOWARDS NORTH SIDE AND 12M TOWARDS SOUTH SIDE.
  - THE EXACT ROAD WIDTH IS NARROW WHICH HAS BEEN EXTENDED AS INDICATED TO 7M TO MEET VEHICLE MOVEMENT REQUIREMENTS.
  - TENTATIVE ROUTING FOR NEW 14" FEED LINE INDICATED. EXACT ROUTING AND LENGTH TO BE ASCERTAINED DURING DETAIL ENGINEERING BY LSTK CONTRACTOR.
  - STRUCTURE SHALL BE MADE COMPLETE FOR GANTRY-2 (INCLUDING FUTURE) & SHALL BE COMPLETE IN ALL ASPECT, EXCEPT THE 6 FUTURE LOADING ARM RELATED INSTRUMENTS AND PIPING AS PER P&ID REQUIREMENT.
  - PROVISION FOR EXTERNAL WATER SUPPLY TO BE MADE AVAILABLE SO AS TO CATER WATER REQUIREMENT SHORTAGE DURING EMERGENCY.
  - IN TOTAL THERE ARE 5 No. OF GATES COMING IN THE TERMINAL BOUNDARY LIMITS AS INDICATED OUT OF WHICH 2 No. OF GATES ARE 7M WIDTH & 3 No. OF GATES ARE 4M WIDTH.

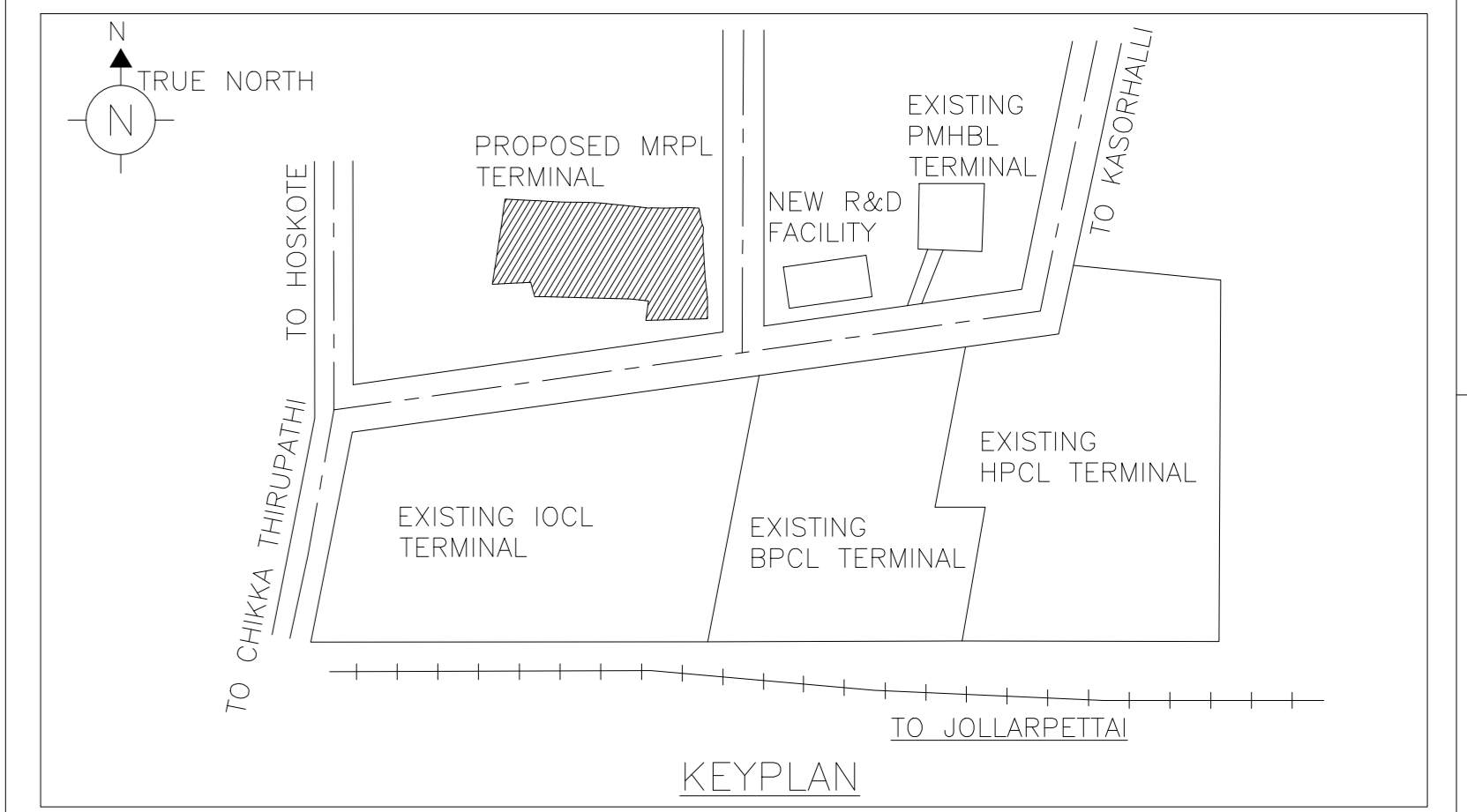
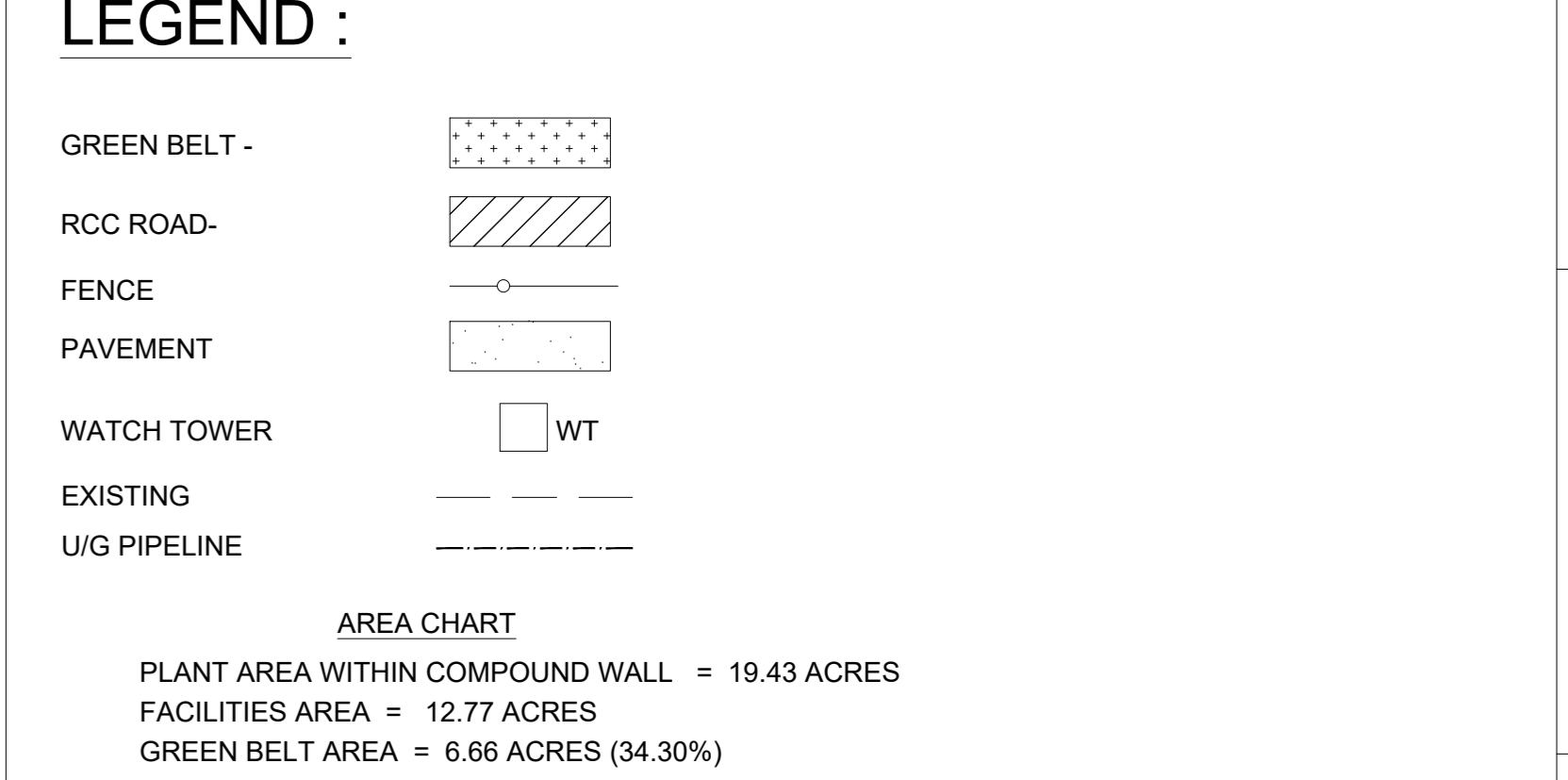

SL.NO	REV.	TITLE
4	20005-GEN-PL-SK-0001	1 SCHEMATIC OF PROPOSED 14" PIPELINE
3		TOPOGRAPHICAL SURVEY OF LAND FOR MRPL
2	MRPL-DEV-PR-LY-101	10 GENERAL LAYOUT
1	3997-31-16-47-1432	0 OVER ALL PLOTTING B'LORE RECEIVING TERMINAL

**REFERENCE DRAWINGS**

SL.NO	REV.	TITLE
4	20005-GEN-PL-SK-0001	1 SCHEMATIC OF PROPOSED 14" PIPELINE
3		TOPOGRAPHICAL SURVEY OF LAND FOR MRPL
2	MRPL-DEV-PR-LY-101	10 GENERAL LAYOUT
1	3997-31-16-47-1432	0 OVER ALL PLOTTING B'LORE RECEIVING TERMINAL

**SITE ADDRESS & LOCATION DETAILS**

ADDRESS OF PREMISES : SY NO. 85P, 158/1, 158/2, 134(P), 135, 136, 137(P), 138, 143, 144, 145(P) WITHIN THE VILLAGE LIMIT OF DODDASARAHALLI, JADIGENAHALLI HOBLI, HOSKOTE TALUK, BANGALORE RURAL DISTRICT-560067

STATE : KARNATAKA  
 DISTRICT : BANGALURU RURAL  
 VILLAGE OR TOWN : DODDASARAHALLI  
 POLICE STATION : ANUGONDANA HALLI  
 NEAREST RAILWAY STATION : DEVANGONTHI

REV.	DATE	DESCRIPTION	DRWN	CHKD	APPRD	MRPL
3	27-APR-21	RE-ISSUED FOR BID	VD/BK	SDK	SDK	
2	05-APR-21	RE-ISSUED FOR BID	VD/BK	SDK	SDK	
1	12-MAR-21	RE-ISSUED FOR BID	VD/BK	SDK	SDK	
0	09-MAR-21	ISSUED FOR BID	VD/BK	SDK	SDK	
C2	8-DEC-20	ISSUED FOR APPROVAL	VD/BK	SDK	SDK	
C1	23-NOV-20	ISSUED FOR APPROVAL	VD/BK	SDK	ASN	

**PROJECT:** CONSTRUCTION OF MARKETING TERMINAL PROJECT AT DEVANGONTHI, BANGALORE.

**PROJECT MANAGEMENT CONSULTANT:**  
**NAUVATA ENGINEERING PVT. LTD.**

**DRAWING TITLE:** OVERALL PLOT PLAN

DRAWING No:	SHT NO.	REV	SCALE:
20005-GEN-L-DW-3001	1 OF 1	3	1:1

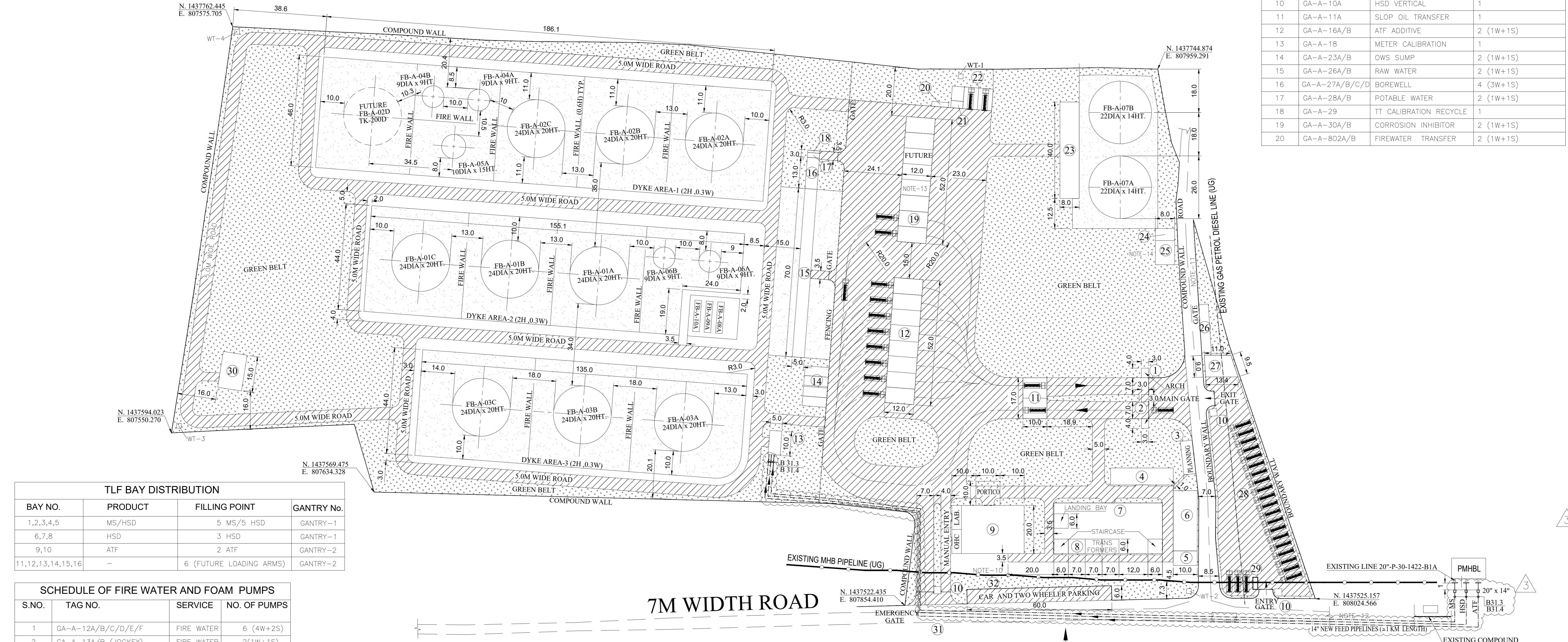

**TLF BAY DISTRIBUTION**

BAY NO.	PRODUCT	FILLING POINT	GANTRY No.
1,2,3,4,5	MS/HSD	5 MS/5 HSD	GANTRY-1
6,7,8	HSD	3 HSD	GANTRY-1
9,10	ATF	2 ATF	GANTRY-2
11,12,13,14,15,16	-	6 (FUTURE LOADING ARMS)	GANTRY-2

**SCHEDULE OF FIRE WATER AND FOAM PUMPS**

S.NO.	TAG NO.	SERVICE	NO. OF PUMPS
1	GA-A-12A/B/C/D/E/F	FIRE WATER	6 (4W+2S)
2	GA-A-13A/B (JOCKEY)	FIRE WATER	2(1W+1S)
3	GA-A-14A/B (SCREW TYPE)	FOAM	2(1W+1S)
4	GA-A-14C/D (CENTRIFUGAL)	FOAM	2(1W+1S)

**SCHEDULE OF FACILITIES**

TAG NO.	DESCRIPTION	SIZE (M) NOTE-3
1	ARCH	25 x 3 x 10(H)
2	MAIN SECURITY CABIN	3 x 3
3	PLANNING ROOM	14 x 5
4	DC SHED	25 x 10 x 2H
5	SEWAGE TREATMENT PLANT-1(STP) & SUMP & PUMPS	10 x 6
6	WARE HOUSE + MAINTENANCE AREA	26 x 7
7	MCC + TRANSFORMER	45 X 15
8	BESCOM TARIFF METERING YARD	6 x 7
9	ADMIN BUILDING + AMENITY + CONTROL ROOM(G+1) +LABORATORY ROOM+OCCUPATIONAL HEALTH CENTRE	30 X 20
10	SECURITY CABIN (3 nos.)	3 x 3
11	TT LOCK & UNLOCK SHED / SURPRISE CHECK	17 X 10
12	TLF GANTRY-1	52 x 12 (8BAYS)
13	PLT MANIFOLD	10 x 5
14	TLD AREA (UNLOADING ETHANOL & BIO-DIESEL/SICK)	10 X 16
15	TLF PUMP HOUSE (INCLUDING MS & HSD ADDITIVE TANKS & PUMPS)	70 X 5
16	VAPOR RECOVERY UNIT	13 x 5
17	CORROSION INHIBITOR SKID	2 x 5
18	ANTISTADIS/ANTIOXIDANT	1 x 5
19	TLF GANTRY-2	52 x 12 (2BAYS + 6 FUTURE)
20	SAMPLING ROOM	7 x 2
21	TROLLEY MOUNTED METER PROVER SYSTEM	3 x 5 x 2H
22	TT CALIBRATION SHED (DUAL BAY) + SUMP	9 X 12 + 6 X 5 (SUMP)
23	FIRE WATER PUMP HOUSE + FOAM TANK + FOAM PUMP + FOAM SUMP + AIR COMPRESSOR	40 x 8
24	FIRE WATER SUMP	8 X 5 X 3 DEPTH
25	RAW WATER TREATMENT PLANT + STORAGE	8 x 10
26	VISITOR PARKING + OFFICER PARKING	20 X 4
27	TEMPORARY PORTABLE CABIN (2 FLOOR WITH TT CREW REST ROOM, TOILET, CANTEN)	-
28	TT PARKING	-
29	TT CHECK SHED	5 X 2
30	OWS	10 x 15
31	EMERGENCY EXIT	-
32	CAR AND TWO WHEELER PARKING	60 x 6

**SCHEDULE OF TANKS**

TANK NO	(DIA X HT) M X M	PRODUCT	LICENCE CAPACITY (KL)	MAX CAPACITY (KL)	TANK TYPE	CLASS
FB-A-01A	24 x 20	MS	8000	9000	IFRVT	A
FB-A-01B	24 x 20	MS	8000	9000	IFRVT	A
FB-A-01C	24 x 20	MS	8000	9000	IFRVT	A
FB-A-02A	24 x 20	HSD	8550	9000	CRVT	B
FB-A-02B	24 x 20	HSD	8550	9000	CRVT	B
FB-A-02C	24 x 20	HSD	8550	9000	CRVT	B
FB-A-02D	24 x 20	HSD (FUTURE)	8550	9000	CRVT	B
FB-A-03A	24 x 20	ATF	8300	9000	CRVT	B
FB-A-03B	24 x 20	ATF	8300	9000	CRVT	B
FB-A-03C	24 x 20	ATF	8300	9000	CRVT	B
FB-A-04A	9 x 9	BIO-DIESEL	550	575	CRVT	B
FB-A-04B	9 x 9	BIO-DIESEL	550	575	CRVT	B
FB-A-05A	10 X 15	INTERFACE	1100	1150	CRVT	B
FB-A-06A	9.0 X 9.0	ETHANOL	550	575	CRVT	A
FB-A-06B	9.0 X 9.0	ETHANOL	550	575	CRVT	A
FB-A-07A	22 X 14	FIRE WATER	4900	5300	CRVT	-
FB-A-07B	22 X 14	FIRE WATER	4900	5300	CRVT	-
FB-A-08A	2.75 X 13.0 LG	SLOP	70	77	UG HOR.	A
FB-A-09A	2.75 X 13.0 LG	MS	70	77	UG HOR.	A
FB-A-10A	2.75 X 13.0 LG	HSD	70	77	UG HOR.	B
FB-A-11A	1.8 X 3.5	FOAM	-	7	VER.	-
FB-A-11B	1.8 X 3.5	FOAM	-	7	VER.	-
FB-A-12A	-	MS ADDITIVE	-	0.9	VER. CYL. CONE BOTTOM	-
FB-A-12B	-	HSD ADDITIVE	-	0.9	VER. CYL. CONE BOTTOM	-
FB-A-13	-	CORROSION INHIBITOR	-	0.5	VER. CYL. CONE BOTTOM	-
FB-A-16A	-	ANTIOXIDANT ADDITIVE	-	0.5	VER. CYL. CONE BOTTOM	-
FB-A-16B	-	STADIS-450 ADDITIVE	-	0.5	VER. CYL. CONE BOTTOM	-
FB-A-16C	-	LUBRICITY ADDITIVE	-	0.5	VER. CYL. CONE BOTTOM	-
FB-A-20	-	RECYCLED WATER	-	5	RECTANGULAR (VTA)	-
FB-A-21	-	RECYCLED WATER	-	2	RECTANGULAR (VTA)	-
FB-A-22	-	RECYCLED WATER	-	1	RECTANGULAR (VTA)	-
FB-A-23	-	RECYCLED WATER	-	0.5	VTA	-



**Mangalore Refinery & Petrochemicals Limited, Devangonthi**

**Separation distances between tanks/other facilities Complying to OISD-244/118. (Required Distances given in Parenthesis)**

Sr. No.	Facility	Sr.No.	1	2	3	4	5	6	7	8	9	10
1	Control room And Admin	x	162.5 (60.00)	168.3 (45.00)	105 (45.00)	45 (45.00)	126.4 (12.00)	22 (6.00)	86.6 (30.00)	298 (30.00)	13.3 (00.00)	
2	Class-A Tank (MS Tank)		162.5 (60.00)	13 (10.00)	35 (30.00)	34 (30.00)	110 (30.00)	182.3 (60.00)	80 (20.00)	71 (8.00)	70 (50.00)	200 (60.00)
3	Class-B Tank (HSD Tank)		168.3 (45.00)	35 (30.00)	13.00 (10.00)	94 (30.00)	67 (30.00)	132.6 (60.00)	24 (20.00)	30 (8.00)	140.2 (50.00)	194.2 (30.00)
4	Class-B Tank (ATF tanks)		105 (45.00)	34 (30.00)	94 (30.00)	18 (10.00)	72 (30.00)	169.7 (60.00)	20.7 (20.00)	40.8 (8.00)	87.3 (50.00)	146.2 (30.00)
5	Tank Lorry Filling Gantry		45 (45.00)	110 (30.00)	67 (30.00)	72 (30.00)	x	60 (60.00)	44.3 (20.00)	34.7 (8.00)	26.5 (50.00)	72.8 (30.00)
6	Fire pump house		126.4 (12.00)	182.3 (60.00)	132.6 (60.00)	169.7 (60.00)	60 (60.00)	x	14 (00.00)	100.80 (60.00)	343.3 (50.00)	126.3 (6.00)
7	Boundary wall around installation		22 (6.00)	80 (20.00)	24 (20.00)	20.7 (20.00)	44.3 (20.00)	14 (00.00)	x	38.3 (6.00)	15 (15.00)	15.1 (15.00)
8	Product Pump House		86.6 (30.00)	71 (8.00)	30 (8.00)	40.8 (8.00)	34.7 (8.00)	100.80 (8.00)	38.3 (6.00)	x	227 (30.00)	121.6 (30.00)
9	Oil Water Sperator		298 (30.00)	70 (50.00)	140.2 (50.00)	87.3 (50.00)	26.5 (50.00)	343.3 (50.00)	15 (15.00)	227 (30.00)	x	340 (45.00)
10	Electrical substation		13.3 (00.00)	200 (60.00)	194.2 (30.00)	146.2 (30.00)	72.8 (30.00)	126.3 (6.00)	15.1 (15.00)	121.6 (30.00)	340 (45.00)	x

All the distances are in Metres.

OR BY ANYMEANS ELECTRONIC, MECHANICAL,PHOTOCOPYING, XEROXING OR OTHERWISE WITHOUT PRIOR PERMISSION FROM NAUVATA ENGINEERING LTD./MRPL ALL RIGHTS RESERVED. NO PART OF THIS DRAWING MAY BE REPRODUCED / STORED IN RETRIEVAL SYSTEM OR TRANSMITTED IN ANY FORM

	<b>MRPL Marketing Terminal Project at Devangonhi, Bangalore</b> <b>Marketing Infrastructure Projects, MRPL</b>				
	Part - E	<b>STANDARD SPECIFICATION FOR OIL FILLED DISTRIBUTION TRANSFORMER</b>	Tender No.:	3200000495	
	Section - E-1		Doc. No. :	20005-GEN-E-SPE-5003	
Subsection-E-1.12	Rev :		0		

<b>E - 1</b>	<b>STANDARD SPECIFICATION</b>
<b>E - 1.12</b>	<b>OIL FILLED DISTRIBUTION TRANSFORMER</b>

## MRPL Marketing Terminal Project at Devangonhi, Bangalore



**PROJECT : MARKETING INFRASTRUCTURE PROJECTS, MRPL**

**OWNER : MANGALORE REFINERY AND PETROCHEMICALS LTD**

**PMC : NAUVATA ENGINEERING PVT. LTD.**

**JOB NO. : JBG20005**



Rev. No	Date	Purpose	Prepared by	Checked by	Approved by
0	13-01-2020	ISSUED FOR BID	ABN	MKV	MKV
C1	11-12-2020	ISSUED FOR REVIEW/COMMENTS	ABN	MKV	MKV

	<b>MRPL Marketing Terminal Project at Devangonthe, Bangalore</b> <b>Marketing Infrastructure Projects, MRPL</b>				
	Part - E	<b>STANDARD SPECIFICATION FOR OIL FILLED DISTRIBUTION TRANSFORMER</b>	Tender No.:	3200000495	
	Section – E-1		Doc. No. :	20005-GEN-E-SPE-5003	
Subsection–E-1.12	Rev :		0		



## TABLE OF CONTENTS

<b>1. SCOPE .....</b>	<b>4</b>
<b>2. CODES &amp; STANDARDS .....</b>	<b>4</b>
<b>3. DEFINITIONS AND ABBREVIATIONS .....</b>	<b>4</b>
3.1 Definitions.....	5
3.2 Abbreviation .....	5
<b>4. GENERAL REQUIREMENTS .....</b>	<b>6</b>
<b>5. SITE CONDITIONS .....</b>	<b>6</b>
<b>6. CONSTRUCTION .....</b>	<b>6</b>
<b>7. TERMINALS AND MARSHALLING BOX .....</b>	<b>7</b>
<b>8. COOLING .....</b>	<b>8</b>
<b>9. TAPPINGS &amp; CONTROL .....</b>	<b>8</b>
<b>10. ACCESSORIES .....</b>	<b>10</b>
<b>11. NOISE LEVEL .....</b>	<b>12</b>
<b>12. INSPECTION AND TESTING .....</b>	<b>12</b>
<b>13. GROUNDING .....</b>	<b>14</b>
<b>14. PAINTING AND FINISHING .....</b>	<b>14</b>
<b>15. PACKING AND DESPATCH .....</b>	<b>15</b>
<b>16. SPECIAL TOOLS .....</b>	<b>15</b>



	<b>MRPL Marketing Terminal Project at Devangonhi, Bangalore</b> <b>Marketing Infrastructure Projects, MRPL</b>				
	Part - E	<b>STANDARD SPECIFICATION FOR OIL FILLED DISTRIBUTION TRANSFORMER</b>	Tender No.:	3200000495	
	Section – E-1		Doc. No. :	20005-GEN-E-SPE-5003	
Subsection–E-1.12	Rev :		0		

17.	SPARES.....	15
18.	QUALITY ASSURANCE .....	15
19.	DEVIATIONS.....	15
20.	GUARANTEE.....	16
21.	LIST OF FITTINGS & ACCESSORIES .....	16
22.	TECHNICAL DETAILS TO BE FILLED IN BY BIDDER -1000 KVA.....	17
23.	VENDOR DRAWINGS & DOCUMENT REQUIREMENT SCHEDULE.....	20

	<b>MRPL Marketing Terminal Project at Devangonhi, Bangalore</b> <b>Marketing Infrastructure Projects, MRPL</b>				
	<b>Part - E</b>	<b>STANDARD SPECIFICATION FOR OIL FILLED DISTRIBUTION TRANSFORMER</b>	Tender No.:		3200000495
	<b>Section – E-1</b>		Doc. No. :		20005-GEN-E-SPE-5003
	<b>Subsection–E-1.12</b>		Rev :		0

## 1. SCOPE

This specification covers the minimum requirements for design, manufacture, assembly, testing packing and supply of Oil filled Power / Distribution Transformers along with nitrogen injection fire protection system (if specified in MR/ Tender).

## 2. CODES & STANDARDS

2.1. The equipment shall comply with the requirements of the latest revision of the following standards issued by BIS. :-

IS: 335	:	New Insulating oils
IS: 1271	:	Thermal evaluation and Classification of electrical insulation
IS: 2026	:	Power transformers
IS: 2099	:	Bushing for Alternative voltages above 1000 V
IS: 2705	:	Current transformers
IS: 3347	:	Dimensions for porcelain Transformer Bushings
IS: 3637	:	Gas operated relays
IS: 3639	:	Fitting & accessories for power transformers
IS: 4201	:	Application guide for CTs.
IS: 6600	:	Guide for loading of oil immersed transformers
IS: 8478	:	Application guide for ON-load tap changers
IS: 8468	:	On-load tap changers
IS/ IEC 60529	:	Degree of protection provided by enclosures (IP Code)
IS/IEC: 60947	:	LV switchgear and control gear.

2.2. In case of imported equipment, standards of the country of origin shall be applicable if these standards are equivalent or stringent than the applicable Indian standards.



2.3. The equipment shall also conform to the provisions of CEA Regulations and any other statutory regulations currently in force in the country.

2.4. In case Indian standards are not available for any equipment, standards issued by IEC/BS/VDE/IEEE/NEMA or equivalent agency shall be applicable.

2.5. In case of any conflict between requirements specified in various applicable documents for the project, the most stringent one shall prevail. However, PMC / COMPANY's decision in this regard will be final and binding.

## 3. DEFINITIONS AND ABBREVIATIONS

The following includes the definition of terminologies and expanded forms of abbreviations.

	<b>MRPL Marketing Terminal Project at Devangonhi, Bangalore</b> <b>Marketing Infrastructure Projects, MRPL</b>				
	Part - E	<b>STANDARD SPECIFICATION FOR OIL FILLED DISTRIBUTION TRANSFORMER</b>	Tender No.:		3200000495
	Section – E-1		Doc. No. :		20005-GEN-E-SPE-5003
	Subsection–E-1.12		Rev :		0

### 3.1 DEFINITIONS

The CLIENT / COMPANY / OWNER where used in this document shall mean the ultimate user / owner of the plant and facilities.

The CONTRACTOR where used in this document shall mean the party, who undertake LSTK / EPC contract for the above project.



The VENDOR / SUPPLIER where used in this document shall mean the party, who manufactures or supplies the equipment and services specified.

The INSPECTOR / TPIA / TPI where used in this document shall mean the PURCHASER / COMPANY or their authorized Third Party Agency for carrying out the inspection.

The PMC where used in this specification shall mean the party, who perform Project Management for COMPANY.

### 3.2 ABBREVIATION

BIS	:	Bureau of Indian Standards
BS	:	British Standard
CBIP	:	Central Board of Irrigation & Power
CEA	:	Central Electrical Authority
CT	:	Current Transformer
GI	:	Galvanised Iron
HV	:	High Voltage
HRC	:	High Rupture Capacity
IEC	:	International Electro technical Commission
IEEE	:	The Institute of Electrical and Electronics Engineers
IP	:	Ingress protection
IS	:	Indian Standard
kV	:	Kilo Volt
kVA	:	Kilo Volt Ampere
LV	:	Low Voltage
MV	:	Medium Voltage
NGR	:	Neutral Grounding Resistor
OLTC	:	ON Load Tap Changer
ONAF	:	Oil Natural Air Forced
ONAN	:	Oil Natural Air Natural

	<b>MRPL Marketing Terminal Project at Devangonhi, Bangalore</b> <b>Marketing Infrastructure Projects, MRPL</b>				
	<b>Part - E</b>	<b>STANDARD SPECIFICATION FOR OIL FILLED DISTRIBUTION TRANSFORMER</b>	Tender No.:		3200000495
	<b>Section – E-1</b>		Doc. No. :		20005-GEN-E-SPE-5003
	<b>Subsection–E-1.12</b>		Rev :		0

OTI	:	Oil Temperature Indicator
PO	:	Purchase Order
PVC	:	Poly Vinyl Chloride
PRV	:	Pressure Release Valve
RTCC	:	Remote Tap Changer Control
TPN	:	Three Phase and Neutral
VDE	:	Vendor Data Evaluation
WTI	:	Winding Temperature Indicator
XLPE	:	Cross Linked Polyethylene

#### 4. GENERAL REQUIREMENTS

The offered equipment shall be brand new with state of art technology and proven field track record. No prototype equipment shall be offered.

Vendor shall ensure availability of spare parts and maintenance support services for the offered equipment for at least 15 years from the date of supply.



Vendor shall give a notice of at least one year to the end user of equipment and COMPANY before phasing out the product/spares to enable the end user for placement of order for spares and services.

#### 5. SITE CONDITIONS

Transformer shall be suitable for installation and satisfactory operation in tropical, humid and corrosive atmospheres. The transformer shall be designed to operate under site conditions as specified in data sheet / project details. If not specifically mentioned therein, design ambient temperature of 35°C and altitude not exceeding 934m above MSL shall be considered.

#### 6. CONSTRUCTION



- 6.1 Transformer tank shall be of welded sheet steel construction and provided with gasket steel cover plates. Base shall be suitably reinforced to prevent any distortion during lifting. Base channels shall be provided with skids and pulling eyes to facilitate handling.
- 6.2 Transformer shall be double wound, core type with high-grade cold rolled non-aging grain oriented low loss, and high permeability silicon steel laminations (M-4 or better grade) perfectly insulated and clamped to minimize vibration and noise. Care shall be taken to insulate core-fastening bolts to reduce losses and avoid hot spots. All parts of magnetic circuit shall be bonded to earth system.
- 6.3 Transformers shall have conventional type of windings. Foil type windings are not acceptable. Windings shall be of copper and shall be designed to withstand the applicable thermal and dynamic short circuit stresses.

	<b>MRPL Marketing Terminal Project at Devangonhi, Bangalore</b> <b>Marketing Infrastructure Projects, MRPL</b>				
	<b>Part - E</b>	<b>STANDARD SPECIFICATION FOR OIL FILLED DISTRIBUTION TRANSFORMER</b>	Tender No.:		3200000495
	<b>Section – E-1</b>		Doc. No. :		20005-GEN-E-SPE-5003
<b>Subsection–E-1.12</b>	Rev :		0		

- 6.4 All covers and seals shall be oil and airtight and shall not be affected by mineral or synthetic oil action. Detachable radiators (tank mounted) equipped with air vent, drain plug and lifting lugs shall be provided with shut-off valves for transformer rated more than or equal to 500kVA to permit removal of any radiator unit without emptying the tank. Radiators shall be securely braced to prevent undue vibration.
- 6.5 All fasteners, bolts etc., shall be galvanized. All surfaces to be painted shall be thoroughly cleaned, de-scaled, made free from rust and transformer shall be epoxy painted.
- 6.6 Different non-current carrying parts of transformers shall be connected by copper flexibles for earth continuity purpose.
- 6.7 Transformer shall be supplied with first filling of oil and 10% extra oil in non -returnable drums. Oil shall conform to IS-335.

## 7. TERMINALS AND MARSHALLING BOX

- 7.1 Windings shall be brought out and terminated on outdoor bushings, cable boxes or bus-duct chamber, which will be located as specified on the data sheet.
- 7.2 When outdoor bushings are specified they shall be supplied complete with terminal connectors suitable for the specified conductor size.
- 7.3 Cable boxes shall be supplied with cable lugs and glands.
- 7.3.1. For HV XLPE Cables and MV XLPE Power/control cables double compression cable glands and crimped type, tinned copper cable lugs shall be supplied. Gland plate shall be removable type. For single core cables, gland plate shall be of non-magnetic material. HV cable box shall be suitable for termination of specified size of XLPE insulated cable. The headroom available between cable gland plate and terminals shall not be less than 600mm for cable up to 11 kV, and 900 mm for 22 kV and 33 kV cables. Cable box and disconnecting chamber shall be air insulated.
- 7.3.2. Cable box shall be weatherproof to IP-55. For fixed portion of cable box, inspection cover with lifting handle shall be provided.
- 7.3.3. Primary cable box (where applicable) shall be able to withstand specified primary system fault level for 0.20 secs.
- 7.4 Terminal chamber for bus-duct termination shall have a gasket cover plate bolted to it and shall be weatherproof to IP-55. A separate inspection cover with lifting handle shall be provided to facilitate connection and inspection. Phase sequence of the bus bars shall be as specified in the data sheets.
- 7.5 Marshalling box shall be mounted on transformer and shall be weatherproof to IP-55. All protective devices and neutral CTs shall be wired by means of XLPE insulated copper conductor armoured cables up to the marshalling box. Terminals shall be clamp type. Removable gland plate with double compression type glands shall be provided. Lamp with switch & socket shall be provided in the marshalling box. Preferably, marshalling box shall be located on the front side of transformer.

	<b>MRPL Marketing Terminal Project at Devangonhi, Bangalore</b> <b>Marketing Infrastructure Projects, MRPL</b>				
	<b>Part - E</b>	<b>STANDARD SPECIFICATION FOR OIL FILLED DISTRIBUTION TRANSFORMER</b>	Tender No.:		3200000495
	<b>Section – E-1</b>		Doc. No. :		20005-GEN-E-SPE-5003
<b>Subsection–E-1.12</b>	Rev :		0		

7.6 For transformers having provisions for terminating TPN bus duct on the 433V side, neutral of the star connected secondary winding shall be brought out to a secondary terminal chamber. A CT shall be mounted (if specified) on the neutral terminal with CT secondary wired up to the marshalling box.

7.7 A separate neutral bushing shall be provided for neutral earthing of transformers. The neutral CT shall be mounted as below:-

- a) CT for 51 G shall be located in the earth path after bifurcation of neutral.
- b) CT for 64 R can be located before bifurcation of neutral.

Supporting arrangement for GI strip/cable as applicable shall be provided for connection of neutral bushing to earth/NGR.

## 8. COOLING

8.1 Type of cooling shall be Oil Natural and Air Natural.

8.2 Forced air-cooling system shall have a weatherproof IP-55 control panel to be installed on the body of the transformer, complete with cooler controls and cable glands necessary for Purchaser's external cable connections. Contacts shall be provided for remote indication/alarm for following operating conditions:

- (i) Auto/manual selection
- (ii) Winding over temperature.
- (iii) Fans ON (for each fan separately) & Fan stripped (for each fan separately).

Cooling fans shall be complete with mounting/supporting structure. These shall be suitably sized to limit the temperature rise of the transformer to specified values with continuous maximum loading of ONAF rating and at maximum specified ambient temperatures. One standby fan per 50% cooler bank shall be provided.

In Auto mode all fans including redundant fans shall be running. In manual mode, provision shall be made for starting each fan independently.



## 9. TAPPINGS & CONTROL

9.1 These shall be provided on high voltage side and connected to off circuit or on-load tap changing gear as specified on data sheet. Under conditions of external short circuit, the tap changing equipment shall be capable of carrying the same current as the windings.

9.2 Off circuit tap changing gear:-

9.2.1. Off circuit tap changing gear shall have an external operating handle mounted on the transformer side and shall meet the following requirements:

- Positive snap-action contact changing
- The mechanism shall be such that it is impossible for the contacts to be set in a position whereby the windings remain open-circuited or partly short-circuited.

	<b>MRPL Marketing Terminal Project at Devangonhi, Bangalore</b> <b>Marketing Infrastructure Projects, MRPL</b>				
	Part - E	<b>STANDARD SPECIFICATION FOR OIL FILLED DISTRIBUTION TRANSFORMER</b>	Tender No.:		3200000495
	Section – E-1		Doc. No. :		20005-GEN-E-SPE-5003
Subsection–E-1.12	Rev :		0		

- Mechanical stops at the ends shall be provided to prevent overrun.
- The driving rod through cover or tank wall shall be properly sealed against oil leakage under all service conditions.

9.2.2. The handle shall be metallic and the adequately sized in order to allow operation without the need of tools and be located in a directly accessible position.

9.2.3. The handle shall be provided with padlock facilities to lock the tap changer in the desired position. Tap positions shall be clearly marked in line with the data given on the rating plate.

9.3 ON load tap changing gear:-

9.3.1. High speed on load tap changing gear with number of steps as specified on the data sheet shall be provided and mounted on the transformer. The OLTC gear shall have diverter resistance and the current diverting contacts shall be housed in a separate oil chamber segregated from the main tank of the transformer. The contacts shall be accessible for inspection and their tips shall be replaceable.

OLTC oil chamber shall have oil filling, drain and sampling facility. It shall be provided with oil level indicator, connection orifices, valves and silica gel breather shall be provided.

9.3.2. OLTC shall be provided with local and remote controls.

9.3.3. OLTC wherever called for shall be suitable for bi-directional power flow.

9.3.3.1 Local Control:-

**i) Manual-Mechanical Control**



The cranking device for operation of the OLTC gear shall be removable and located at a height not exceeding 1500mm above ground level for easy operation. The mechanism shall be complete with normal accessories including at least the following:-

- A mechanical tap position indicator (Rated tap voltages shall be marked on the diagram plate).
- A mechanical operation counter.
- Mechanical stops to prevent over cranking of the mechanism beyond extreme tap positions.

**ii) Electrical Control**

Control circuit shall incorporate the following:-

- “Local/Remote” manual electrical operation.
- Device to ensure a positive and full completion of tap change once it is initiated even if there is loss of power.
- An interlock to cut-off electrical control automatically upon recourse being taken to manual mechanical control in emergency.
- Electrical interlock to cut-off a counter impulse for a reverse tap change, being initiated during a progressive tap change and until the mechanism

	<b>MRPL Marketing Terminal Project at Devangonhi, Bangalore</b> <b>Marketing Infrastructure Projects, MRPL</b>				
	Part - E	<b>STANDARD SPECIFICATION FOR OIL FILLED DISTRIBUTION TRANSFORMER</b>	Tender No.:		3200000495
	Section – E-1		Doc. No. :		20005-GEN-E-SPE-5003
Subsection–E-1.12	Rev :		0		

comes to rest and resets circuits for a fresh operation.

- All auxiliaries and devices for electrical control of OLTC gear should be housed in a weather-proof cabinet mounted on the transformer and shall include:-
  - Local tap position indicator
  - 5 digit operation counter
  - Cubicle lighting
  - Thermostatically controlled space heater.
  - Miniature circuit breaker with magnetic and thermal overload devices for controlling the incoming supply to the OLTC motor.
  - Padlocking arrangement for the hinged cabinet door.
  - Removable plate with cable glands.
  - Inside tag with control scheme indelibly marked

#### 9.3.3.2 Remote Tap Changer Control Panel:-

a) Remote Tap Changer control panel shall comprise of the following:-

- Individual/parallel control on Master follower sequence selector switch.
- Raise/lower, control switch.
- Potentiometer type tap position indicator.
- Out of step relay.
- Time delay relay.
- Indicating lamp for out of step.
- Out of step buzzer.
- Indicating lamp for tap changer supply available.
- Indicating lamp for tap change in progress.
- Voltage Sensing Relay (If specified)



b) RTCC panel shall be dust & vermin proof, floor mounting and freestanding type. The enclosure shall be cold rolled sheet of 2.0 mm thick. All doors and opening shall be provided with neoprene gaskets.

## 10. ACCESSORIES

10.1 The following accessories shall be provided as a minimum:-



- i) Rating and diagram Plate
- ii) Terminal marking Plate
- iii) Two earthing terminals
- iv) De-hydrating breather(For transformer rated 25 kVA and above for rated voltage



	<b>MRPL Marketing Terminal Project at Devangonhi, Bangalore</b> <b>Marketing Infrastructure Projects, MRPL</b>				
	<b>Part - E</b>	<b>STANDARD SPECIFICATION FOR OIL FILLED DISTRIBUTION TRANSFORMER</b>	Tender No.:		3200000495
	<b>Section – E-1</b>		Doc. No. :		20005-GEN-E-SPE-5003
<b>Subsection–E-1.12</b>	Rev :		0		

11 kV and below, and all ratings above 11kV)

- v) Conservator (For transformer rated 50 kVA and above for rated voltage 11 kV and below, and all ratings above 11kV)
  - vi) Air release Device (for transformers with conservator)
  - vii) Oil filling hole with cover
  - viii) Oil Level indicator with alarm contact
  - ix) Thermometer pocket
  - x) Oil temperature indicator with alarm & trip contacts
  - xi) Winding temperature indicator with alarm & trip contacts (for transformers of rating 500 KVA and above)
  - xii) 4-20mA transducers for OTI & WTI (For Transformers rated above 1000kVA)
  - xiii) Pressure relief valve shall be provided (with alarm contact).
  - xiv) Sampling valve
  - xv) Conservator drain valve
  - xvi) Top oil filter valve
  - xvii) Drain cum bottom filter valve
  - xviii) Double float Buchholz relay
  - xix) Separate neutral bushing outside terminal box with connector assembly
  - xx) Inspection cover
  - xxi) Terminal box
  - xxii) Marshalling box
  - xxiii) Lifting lugs
  - xxiv) Jacking lugs
  - xxv) Cross channels with towing lugs
- 10.2 Conservator shall be complete with oil filling plug and cap, oil drain valve, oil level gauge in addition to magnetic oil level gauge. A flexible oil resistance air bag shall be provided for conservator for transformer rated above 2500kVA. Air bag shall be designed to withstand repeated expansion and contraction due to changes in oil level.
- 10.3 Separate buchholz relay shall be provided for main tank and OLTC chamber. This shall be double float type for the main tank with separate normally open trip and alarm contacts. For the OLTC chamber the relay shall be of single float type or oil surge relay with one trip contact. Isolating valve shall be provided on either side of the relay and distance piece shall be supplied.
- 10.4 Size of valves for drain, filter and sampling shall be as per table below:-

	<b>MRPL Marketing Terminal Project at Devangonhi, Bangalore</b> <b>Marketing Infrastructure Projects, MRPL</b>				
	Part - E	<b>STANDARD SPECIFICATION FOR OIL FILLED DISTRIBUTION TRANSFORMER</b>	Tender No.:		3200000495
	Section – E-1		Doc. No. :		20005-GEN-E-SPE-5003
Subsection–E-1.12	Rev :		0		

Transformer rating (kVA)	Size of drain valve (mm)	Size of filter valve mm	Size of sampling valve mm
Up to 1600	25	25	15
>1600 to 10000	50	25	15
>10000 to 25000	80	50	15
>25000 to 50000	100	50	15
>50000	100	50	15

10.5 ECS Interface signals as listed below shall be provided if specified in the data sheet / projects specifications.

- i) Selector switch status (OLTC/RTCC/Remote Control mode)
- ii) Master / Follower status
- iii) Auto/Manual mode status
- iv) Tap changer out of step status
- v) Tap changer stuck status
- vi) Tap changer status signal (Digital) for each step
- vii) Control Supply failure for RTCC Panel/OLTC
- viii) Raise/Lower Control from ECS

## 11. NOISE LEVEL



Audible Noise level shall not exceed the limits indicated in CBIP manual.

## 12. INSPECTION AND TESTING

12.1 Owner's representative shall be given free access in the works from time to time for stage wise inspection and progress reporting. Four weeks advance notice shall be given to witness the final routine test as per IS: 2026 and other tests as agreed upon. These tests shall be performed on the complete assembly at manufacturer's works. Test certificates duly signed by owner's representative shall be issued as part of final document.

12.2 Routine tests and special tests as listed below shall be carried out on all transformers:-

- GA along with verification of all accessories
- Dimensional & electrical clearance
- Rating plate details
- Terminal/ tapping markings
- Earthing arrangement
- Measurement of winding resistance

	<b>MRPL Marketing Terminal Project at Devangonhi, Bangalore</b> <b>Marketing Infrastructure Projects, MRPL</b>				
	Part - E	<b>STANDARD SPECIFICATION FOR OIL FILLED DISTRIBUTION TRANSFORMER</b>	Tender No.:		3200000495
	Section – E-1		Doc. No. :		20005-GEN-E-SPE-5003
Subsection–E-1.12	Rev :		0		

- Measurement of voltage ratio and check of voltage vector relationship
- Measurement of impedance voltage and load loss
- Measurement of no- load loss and current
- Measurement of efficiency and voltage regulation
- Induced over voltage withstand test
- Separate-source voltage withstand test (HV Test)
- Measurement of insulation resistance before and after HV test
- Noise level check
- Magnetic Balance test
- Dielectric test
- BDV on transformer oil
- Tests on OLTC/ control panel (if applicable)
- Measurement of power taken by fans & oil pumps (on sample basis on one transformer)

### 12.3 Additional Tests:-

- 12.3.1. Oil leakage Test - All tanks and oil filled compartments shall be tested for oil tightness by being completely filled with air/oil of a viscosity not greater than that of insulating oil to IS: 335 at an ambient temperature and subjected to a pressure equal to the normal pressure plus 35 kN/m<sup>2</sup> measured at the base of the tank. This pressure shall be maintained for a period of not less than 12 hours for oil and 1 hour for air, during which time no leakage shall occur.
- 12.3.2. Vacuum Test - One transformer tank of each size shall be subjected to the specified vacuum as in table-1. The tanks designed for vacuum of 760mm of mercury shall be tested at a maximum internal pressure of 3.33 kN/m<sup>2</sup> (25mm of Hg) for one hour. The permanent deflection of flat plates after the vacuum has been released shall not exceed the value specified in Table-2 without affecting the performance of the transformer.

**Table — 1**

Highest System Voltage	MVA Rating	Vacuum Gauge pressure kN/m <sup>2</sup>	mm of HG
Up to 72kv	up to 1.6	34.7	250
	above 1.6 & up to 20	68.0	500
	Above 20	100.64	760
Above 72kv	For all MVA ratings		



	<b>MRPL Marketing Terminal Project at Devangonhi, Bangalore</b> <b>Marketing Infrastructure Projects, MRPL</b>				
	Part - E	<b>STANDARD SPECIFICATION FOR OIL FILLED DISTRIBUTION TRANSFORMER</b>	Tender No.:		3200000495
	Section – E-1		Doc. No. :		20005-GEN-E-SPE-5003
	Subsection–E-1.12		Rev :		0

Table — 2

Horizontal length of flat plate (in mm)	Permanent deflection (in mm)
Up to and including 750	5
751 to 1250	6.5
1251 to 1750	8
1751 to 2000	9.5
2001 to 2250	11
2251 to 2500	12.5
2501 to 3000	16
Above 3000	19

- 12.3.3. Pressure Test - One transformer tank of each size shall be subjected to a pressure corresponding to twice the normal head of oil or to the normal pressure plus 35 kN/m<sup>2</sup> whichever is lower measured at the base of the tank and will be maintained for one hour. The permanent deflection of flat plates after the excess pressure has been released shall not exceed the figure specified in Table-2.
- 12.3.4. One transformer of each rating shall be subjected to heat run test, if specified in data sheet.
- 12.3.5. Impulse test, if specified in the data sheet, shall be carried out on all three limbs of the transformer.
- 12.3.6. Transformer shall be subjected to short circuit test, if specified in the data sheet.

### 13. GROUNDING

- 13.1 Two grounding pads with two tapped holes of size M10 G.I. bolts & spring washer to be provided on opposite side of the tank for connection to station ground mat. The grounding shall have clean buffed surface suitable for connecting 75 x 10 G.I. Strip.
- 13.2 Ground terminals shall also be provided on marshalling box to ensure grounding.



### 14. PAINTING AND FINISHING

All steel surfaces shall be thoroughly cleaned by sand blasting or chemical agents, as required, to produce a smooth surface free of scales, grease and rust.

The internal surfaces in contact with insulating oil shall be painted with heat resistant insulating varnish which shall not react with the insulating liquid used.

The external surfaces, after cleaning, shall be given a coat of high-quality epoxy primer followed by epoxy intermediate coat and polyurethane top coat with 5 to 6 mils total thickness for corrosive environment.

All equipment shall be epoxy painted and colour shade of all electrical equipment shall be as below.

	<b>MRPL Marketing Terminal Project at Devangonhi, Bangalore</b> <b>Marketing Infrastructure Projects, MRPL</b>				
	Part - E	<b>STANDARD SPECIFICATION FOR OIL FILLED DISTRIBUTION TRANSFORMER</b>	Tender No.:		3200000495
	Section – E-1		Doc. No. :		20005-GEN-E-SPE-5003
Subsection–E-1.12	Rev :		0		

- Outdoor located equipment : 632 as per IS: 5
- Indoor equipment : 631 as per IS: 5

#### 15. PACKING AND DESPATCH

All the equipment shall be divided into several sections for protection and ease of handling during transportation. The equipment shall be properly packed for the selected mode of transportation i.e. by ship/ rail or trailer. The equipment shall be wrapped in polythene sheets before being placed in the crates/ cases to prevent damage to the finish. Crates / cases shall have skid bottom for handling. Special notations such as 'Fragile', 'This side up', 'Centre of gravity', 'Weight', 'Owner's particulars', 'P.O. numbers' etc., shall be clearly marked on the package together with other tag numbers, P.O. number etc.,

The equipment may be stored outdoors for long periods before erection. The packing shall be suitable for outdoor storage in areas with heavy rains/ high ambient temperature.

#### 16. SPECIAL TOOLS

A set of special tools which are necessary or convenient for erection, commissioning, maintenance and overhauling of the equipment shall be included in the scope of supply.

The tools shall be shipped in separate containers, clearly marked with the name of the equipment for which they are intended.

#### 17. SPARES

The Bidder shall submit a list of recommended spare parts for two (2) years satisfactory and trouble free operation, indicating the itemized price of each item of the spares.

Also, required commissioning of spares shall be provided by seller free of cost.

#### 18. QUALITY ASSURANCE



Manufacturer shall follow his standard procedures for Quality Assurance and control. However, the standard procedures shall be submitted to the owner in extent of order.

The procedure shall be in such a form as to clearly delineate the manufacturing sequence and major inspection points and to reference manufacturer's test and inspection procedures.

The Purchaser/Owner will inform the manufacturer as to which of the Inspection points and tests will be witnessed.

#### 19. DEVIATIONS

Any deviations from the requirements of this specification shall be stated as exceptions in bidder / vendor's proposal. Unless specific exceptions are stated, it shall be understood that the equipment is in complete accordance with the specification.



	<b>MRPL Marketing Terminal Project at Devangonhi, Bangalore</b> <b>Marketing Infrastructure Projects, MRPL</b>				
	<b>Part - E</b>	<b>STANDARD SPECIFICATION FOR OIL FILLED DISTRIBUTION TRANSFORMER</b>	Tender No.:		3200000495
	<b>Section – E-1</b>		Doc. No. :		20005-GEN-E-SPE-5003
<b>Subsection–E-1.12</b>	Rev :		0		

## 20. GUARANTEE

Guarantee shall be for proper design, installation and workmanship. Vendor/contractor shall guarantee all performance parameters. The guarantee shall be for a period of 12 months from the date of commissioning or 18 months from the date of last supply whichever is earlier.

## 21. LIST OF FITTINGS & ACCESSORIES



Each transformer shall be equipped with fittings and accessories as listed below:-	
1	Oil conservator with oil level indicator, filler cap and drain plug.
2	Silica gel breather with connecting pipe and oil seal.
3.	Air release device.
4.	Dial type Magnetic Oil Level gauge with low level alarm contacts.
5.	Dial type Winding Temperature indicator with maximum reading pointer & alarm & trip contacts.
6.	150 mm dial oil temperature indicator with maximum reading pointer & alarm & trip contacts.
7.	Thermometer pockets and sensing element for W.T.I & O.T.I on transformer.
8.	Explosion vent with double diaphragm & equalizer pipe with trip contact.
9.	Filter valves (top and bottom) with double flange.
10.	Necessary valves for detachable cooler unit.
11.	Drain valve with double flange.
12	Sampling valve with plug.
13	Jacking pads handling and lifting lugs.
14.	Cover lifting eyes.
15.	Bi-directional rollers and skids.
16.	Hand hole of sufficient size for access to interior of the tank.
17.	Two earthing terminals.
18.	Rating & diagram plate and terminal marking plates.

	<b>MRPL Marketing Terminal Project at Devangonhi, Bangalore</b> <b>Marketing Infrastructure Projects, MRPL</b>				
	<b>Part - E</b>	<b>STANDARD SPECIFICATION FOR OIL FILLED DISTRIBUTION TRANSFORMER</b>	Tender No.:		3200000495
	<b>Section – E-1</b>		Doc. No. :		20005-GEN-E-SPE-5003
<b>Subsection–E-1.12</b>	Rev :		0		

19.	Double float Buchholz relay with alarm & trip contacts.
20.	Separate Neutral bushing outside terminal box with connector assembly.
21.	Marshalling Box.
22.	Off Circuit Tap switch handle with position indicator & locking device.
23.	Warning plate for Off Circuit Tap Switch.



**22. TECHNICAL DETAILS TO BE FILLED IN BY BIDDER -1000 KVA**

SL. NO.	DESCRIPTION	PURCHASER'S REQUIREMENT	BIDDER TO FILL IN
1	Make	ABB/BBL/CGL/EMCO/ SIEMENS/Volt amp/Equivalent	
2	Applicable standards	Vendor to specify	
3	Type / Service	Outdoor / Continuous duty	
4	Rated output	1000 kVA	
5	Rated voltage – Primary / Secondary	11 kV / 0.433 kV	
6	Rated current – Primary / Secondary	84 Amps / 1392 Amps	
7	Rated frequency / No. of phases	50Hz ± 3% / 3 Phase	
8	Vector group reference	Dyn 11	
9	Winding material /core lamination type	Copper / CRGO	
10	Type of cooling	ONAN	
SL. NO.	DESCRIPTION	PURCHASER'S REQUIREMENT	BIDDER TO FILL IN
11	Temperature rise over ambient 50°C:-		
	A   In oil by thermometer	45°C	



	<b>MRPL Marketing Terminal Project at Devangonhi, Bangalore</b> <b>Marketing Infrastructure Projects, MRPL</b>				
	<b>Part - E</b>	<b>STANDARD SPECIFICATION FOR OIL FILLED DISTRIBUTION TRANSFORMER</b>	Tender No.:		3200000495
	<b>Section – E-1</b>		Doc. No. :		20005-GEN-E-SPE-5003
<b>Subsection–E-1.12</b>	Rev :		0		

	B	In winding by resistance	50°C	
12	Tap changer provided on Primary:-			
	A	Local control	Manual	
	B	Capacity	Full range	
	C	Range - Steps & % Variation	± 5 %	
13	Insulation level:-		Primary	Secondary
	A	Rated one minute power frequency withstand voltage	20 kV	3kV
14	Impedance at principal tap:-			
	A	Impedance guaranteed	5% ± 10%	
	B	Reactance	*	
	C	Resistance at 75°C	*	
	D	Zero sequence impedance	*	
	E	Zero sequence capacitance of Primary	*	
15	Parallel operation of transformer		Yes	
16	Guaranteed losses at principal tap at 75°C			
	A	50% load losses guaranteed	2.17 kW	
	B	100% Load losses guaranteed	5.26 kW	
	C	Cooler losses (Radiator)	N/A	
17	Efficiency at 0.8 lag, 0.9 lag, and Unity PF:-			
	A	At full load	*	
	B	At 1/2 full load	*	
18	Regulation at full load :-			
	A	At 0.8 power factor lagging	*	



	<b>MRPL Marketing Terminal Project at Devangonhi, Bangalore</b>				
	<b>Marketing Infrastructure Projects, MRPL</b>				
	<b>Part - E</b>	<b>STANDARD SPECIFICATION FOR OIL FILLED DISTRIBUTION TRANSFORMER</b>	Tender No.:		3200000495
	<b>Section – E-1</b>		Doc. No. :		20005-GEN-E-SPE-5003
<b>Subsection–E-1.12</b>	Rev :		0		

SL. NO.	DESCRIPTION	PURCHASER'S REQUIREMENT	BIDDER TO FILL IN
	B At 0.9 power factor lagging	*	
	C At unity power factor	*	
19	Sound level maximum at 1M distance	80 dB	
20	With stand time for 3 phase / single phase short circuit at terminal, with rated voltage maintained on the other side	2 Sec.	
21	Terminal arrangement :-		
	A Primary	Suitable for 11/11 kV (UE) 1R # 3C x 300 mm <sup>2</sup> XLPE; Aluminum Cable (A2xFY).	
	B Secondary	Suitable for 1600 A L.V. Bus duct with Flange connection	
22	Transformer bushing voltage class:-		
	A Primary / Secondary / Neutral	*	
	B Creep age distance	*	
23	Bushings : Make / Type	*	
24	Fittings & accessories	* Vendor to furnish	
25	Current transformers:-		
	Secondary side Neutral		
	A CT-1		
	i Ratio	1600 / 1A	
	ii Service / Accuracy class	Protection / CL. : 5P20, 20VA	
26	Auxiliary supply:-		
	Relays/ Indicators	110V DC	
	Space heater/ illumination/ receptacle	230V, 1-phase, 50 Hz A.C.	
27	Approx. Quantity of oil required for first filling	*	

	<b>MRPL Marketing Terminal Project at Devangonhi, Bangalore</b>				
	<b>Marketing Infrastructure Projects, MRPL</b>				
	<b>Part - E</b>	<b>STANDARD SPECIFICATION FOR OIL FILLED DISTRIBUTION TRANSFORMER</b>	Tender No.:		3200000495
	<b>Section – E-1</b>		Doc. No. :		20005-GEN-E-SPE-5003
<b>Subsection–E-1.12</b>	Rev :		0		

28	Paint type & shade	632 as per IS: 5	
29	Overall dimensions	*	
<b>SL. NO.</b>	<b>DESCRIPTION</b>	<b>PURCHASER'S REQUIREMENT</b>	<b>BIDDER TO FILL IN</b>
30	Approx. weight in Kg. :-		
	A Core & Windings	*	
	B Tank & Fittings	*	
	C Oil	*	
	D Total weight	*	
31	Weight of Core & Coil /Tank and Fittings/ Oil	*	
32	Commissioning spares	*	
33	Spare parts for 2 years	*	
34	Tests : Standard test & Special test	As per IS / IEC Standards	

**NOTE:**

‘\*’ Vendor to furnish the required information along with the quote.

**23. VENDOR DRAWINGS & DOCUMENT REQUIREMENT SCHEDULE**

FOLLOWING ENGINEERING DATA IS TO BE SUBMITTED BY THE VENDOR WITH OFFER AND AS PART OF PURCHASE ORDER. EQUIPMENT ITEM NO. AND ENQUIRY/P.O. NO. TO BE CLEARLY MARKED ON ALL DRAWINGS / DATA.



P/X = PRINT/XEROX.

S= REPRODUCIBLE SEPIA/



ORIGINAL

IN COMPACT DISKETTE

SR. NO.	ENGINEERING DATA	REQUIRE D	REQUIRED AFTER P.O.		REMARK S
		WITH OFFER	FOR APPROVA L	CERTIFIE D FINAL	
		P/X	P/X	P/X S	
1.	OVERALL DIMENSIONAL DWG. WITH SPACE				

	<b>MRPL Marketing Terminal Project at Devangonhi, Bangalore</b> <b>Marketing Infrastructure Projects, MRPL</b>				
	Part - E	<b>STANDARD SPECIFICATION FOR OIL FILLED DISTRIBUTION TRANSFORMER</b>	Tender No.:	3200000495	
	Section – E-1		Doc. No. :	20005-GEN-E-SPE-5003	
	Subsection–E-1.12		Rev :	0	



	REQUIRED FOR OPERATION & MAINTENANCE	2	3	6	1	
2.	HV AND LV BUSHING DWG / CATALOGUE	2	3	6	1	
3.	LV CABLE BOX G.A. DWG	2	3	6	1	
4.	G.A OF MARSHALLING BOX	-	3	6	1	
5.	WIRING DIAGRAMS WITH TERMINATION DETAILS	2	3	6	1	
<b>SR. NO.</b>	<b>ENGINEERING DATA</b>	<b>REQUIRE D</b>	<b>REQUIRED AFTER P.O.</b>	<b>REMARK S</b>		
		<b>WITH OFFER</b>	<b>FOR APPROVAL</b>	<b>CERTIFIED FINAL</b>		
		<b>P/X</b>	<b>P/X</b>	<b>P/X</b>	<b>S</b>	
6.	TRANSFORMER NAME PLATE DETAILS	-	3	6	1	
7.	BILL OF MATERIALS INDICATING S.NO.,DESCRIPTION,TYPE REFERENCE, MAKE AND QUANTITY	2	3	6	1	
8.	FILLED IN TECHNICAL PARTICULARS	2	3	6	1	
9.	LIST OF CUSTOMERS	2	-	-	-	
10.	TEST CERTIFICATES FOR ALL COMPONENTS AS APPLICABLE a) ROUTINE TEST b) TYPE TEST c) PERFORMANCE TEST d) STATUTORY AUTHORITIES IF ANY	- (Ref. Note 3)	-	6	1	
11.	TECHNICAL CATALOGUE OF ALL THE COMPONENTS & LIST OF USERS	2	1	6	1	
12.	INSTALLATION & OPERATION MANUAL	-	1	6	1	
13.	DETAILS OF UTILITY REQUIREMENT	2	-	-	-	

	<b>MRPL Marketing Terminal Project at Devangonhi, Bangalore</b> <b>Marketing Infrastructure Projects, MRPL</b>				
	<b>Part - E</b>	<b>STANDARD SPECIFICATION FOR OIL FILLED DISTRIBUTION TRANSFORMER</b>	Tender No.:	3200000495	
	<b>Section – E-1</b>		Doc. No. :	20005-GEN-E-SPE-5003	
<b>Subsection–E-1.12</b>	Rev :		0		

14.	BASE FRAME DETAILS	-	-	-	-	
15.	PRICED SPARES LIST FOR 2 YEARS SERVICE	2	-	-	-	
16.	LIST OF SPECIAL TOOLS REQUIRED FOR OPERATION & MAINTENANCE	2	-	-	-	
17.	LIST OF COMMISSIONING SPARES	2	-	-	-	
18.	QUALITY ASSURANCE PLAN	2	3	6	1	
19.	DEVIATIONS IF ANY	2	3	-	-	

## NOTES:

1. FINAL DOCUMENTS TO BE SUBMITTED SEPERATELY IN A FOLDER FOR EACH ITEM.
2. TYPE TEST CERTIFICATES TO BE ENCLOSED ALONG WITH THE BID FOR REVIEW.

	<b>MRPL Marketing Terminal Project at Devangonhi, Bangalore</b> <b>Marketing Infrastructure Projects, MRPL</b>				
	Part - E	<b>STANDARD SPECIFICATION FOR ELECTRICAL MOTOR OPERATED VALVE ACTUATORS</b>	Tender No.:	3200000495	
	Section – E-7		Doc. No. :	20005-GEN-E-SPE-5011	
Subsection – E-7.11	Rev :		01		

<b>E - 7</b>	<b>STANDARD SPECIFICATION</b>
<b>E - 7.11</b>	<b>ELECTRICAL MOTOR OPERATED VALVE ACTUATORS</b>

## MRPL Marketing Terminal Project at Devangonhi, Bangalore



**PROJECT : MARKETING INFRASTRUCTURE PROJECTS, MRPL**

**OWNER : MANGALORE REFINERY AND PETROCHEMICALS LTD**

**PMC : NAUVATA ENGINEERING PVT. LTD.**



**JOB NO. : JBG20005**

1	16-04-2021	RE ISSUED FOR BID	ABN	MKV	MKV
0	04-02-2021	ISSUED FOR BID	ABN	MKV	MKV
C1	03-02-2021	ISSUED FOR REVIEW/COMMENTS	ABN	MKV	MKV
<b>Rev. No</b>	<b>Date</b>	<b>Purpose</b>	<b>Prepared by</b>	<b>Checked by</b>	<b>Approved by</b>



	<b>MRPL Marketing Terminal Project at Devangonhi, Bangalore</b> <b>Marketing Infrastructure Projects, MRPL</b>				
	Part - E	<b>STANDARD SPECIFICATION FOR ELECTRICAL MOTOR OPERATED VALVE ACTUATORS</b>	Tender No.:	3200000495	
	Section – E-7		Doc. No. :	20005-GEN-E-SPE-5011	
	Subsection – E-7.11		Rev :	01	

## TABLE OF CONTENTS

<b>1. SCOPE</b> .....	<b>4</b>
<b>2. CODES &amp; STANDARDS</b> .....	<b>4</b>
<b>3. DEFINITIONS AND ABBREVIATIONS</b> .....	<b>4</b>
3.1 DEFINITIONS.....	5
3.2 ABBREVIATION.....	5
<b>4. GENERAL REQUIREMENTS</b> .....	<b>5</b>
<b>5. SITE CONDITIONS</b> .....	<b>6</b>
<b>6. POWER SUPPLY</b> .....	<b>6</b>
<b>7. TECHNICAL SPECIFICATIONS</b> .....	<b>6</b>
7.1 MOTOR .....	6
7.2 INTEGRAL STARTER AND CONTROL TRANSFORMER .....	7
7.3 INTEGRAL PUSH BUTTON, SELECTOR SWITCHES, INDICATIONS AND CONTROL DEVICES .....	7
7.4 TORQUE AND TRAVEL LIMIT SWITCHES .....	7
7.5 <b>ENCLOSURES</b> .....	8
7.6 CONTROL FACILITIES.....	8
7.7 INTERFACE WITH OWNER'S PLC / DCS / REMOTE PUSH BUTTON STATION.....	9
7.8 <b>DATA LOGGER</b> .....	9
7.9 HAND OPERATION.....	10
7.10 TWO-WIRE CONTROL SYSTEM.....	10
7.11 DIGITAL CONTROL SYSTEM .....	10
7.12 REMOTE POSITION INDICATOR .....	10
7.13 NAMEPLATE .....	11
7.14 WIRING AND TERMINALS.....	11
<b>8. EQUIPMENT FOR CLASSIFIED HAZARDOUS AREAS</b> .....	<b>11</b>

	<b>MRPL Marketing Terminal Project at Devangonhi, Bangalore</b> <b>Marketing Infrastructure Projects, MRPL</b>				
	Part - E	<b>STANDARD          SPECIFICATION FOR          ELECTRICAL MOTOR          OPERATED VALVE          ACTUATORS</b>	Tender No.:	3200000495	
	Section – E-7		Doc. No. :	20005-GEN-E-SPE-5011	
	Subsection – E-7.11		Rev :	01	

<b>9. FIRE PROOFING</b> .....	<b>12</b>
10. INSPECTION, TESTING AND ACCEPTANCE .....	12
11. SPARE PARTS .....	13
12. QUALITY ASSURANCE .....	13
13. GUARANTEE .....	13
14. PACKING AND DESPATCH .....	13
<b>15. SUPERVISION OF INSTALLATION &amp; COMMISSIONING OF ACTUATOR</b> .....	<b>13</b>

	<b>MRPL Marketing Terminal Project at Devangonhi, Bangalore</b> <b>Marketing Infrastructure Projects, MRPL</b>				
	<b>Part - E</b>	<b>STANDARD SPECIFICATION FOR ELECTRICAL MOTOR OPERATED VALVE ACTUATORS</b>	Tender No.:	3200000495	
	<b>Section – E-7</b>		Doc. No. :	20005-GEN-E-SPE-5011	
<b>Subsection – E-7.11</b>	Rev :		01		

## 1. SCOPE

The scope of this specification covers design, manufacture, assembly, shop testing and supply of **Non-Intrusive Type Intelligent Electrical Actuator** intended for fully/ partially opening and closing valve duty with inching facility.



## 2. CODES & STANDARDS

2.1. The equipment shall comply with the requirements of latest revision of the following standards issued by BIS (Bureau of Indian Standards) unless specified otherwise:-

IS: 5	Colors for ready mixed paints and enamels
IS: 12615	“Line Operated Three Phase A.C. Motors” (IE CODE) - Efficiency Classes and Performance Specification.
IS 2148	Flameproof enclosures for electrical apparatus
IS 4722	Rotating electrical machines – Specification
IS 9334	Electric motor operated Actuators
IS 4691	Degree of protection provided by enclosure for rotating electrical machinery
IS/IEC 60034-1	Rotating electrical machines- Rating & Performance
IS/IEC 60529	Degrees of protection provided by enclosure for rotating electrical Machinery
IS/IEC 60079	Electrical apparatus for explosive gas atmospheres
EN 15714-2/IS 9334	Electric Motor Operated Actuators for Industrial valves
IS/IEC 60947	Low Voltage Switchgear and Control gear (Parts-1, 3, 4 & 5)

2.2. In case of imported equipment, the standards of the country of origin shall be applicable if these standards are equivalent or more stringent than the applicable Indian standards.

2.3. The equipment shall also conform to the provisions of Central Electricity Authority Regulation and other statutory regulations currently in force in the country.



2.4. In case Indian standards are not available for any equipment, standards issued by IEC/ BS/VDE/ IEEE/ NEMA or equivalent agency shall be applicable.

2.5. In case of any contradiction between various referred standards/ specifications/ data sheets and statutory regulations, the most stringent requirement shall govern and decision of Owner in this regard shall be final and binding.

## 3. DEFINITIONS AND ABBREVIATIONS

The following includes the definition of terminologies and expanded forms of abbreviations.



	<b>MRPL Marketing Terminal Project at Devangonhi, Bangalore</b> <b>Marketing Infrastructure Projects, MRPL</b>				
	<b>Part - E</b>	<b>STANDARD SPECIFICATION FOR ELECTRICAL MOTOR OPERATED VALVE ACTUATORS</b>	Tender No.:		3200000495
	<b>Section – E-7</b>		Doc. No. :		20005-GEN-E-SPE-5011
<b>Subsection – E-7.11</b>	Rev :		01		

### 3.1 DEFINITIONS

The CLIENT / COMPANY / OWNER where used in this document shall mean the ultimate user / owner of the plant and facilities.

The CONTRACTOR / PURCHASER where used in this document shall mean the party, who undertake LSTK / EPC contract for the above project.

The VENDOR / SUPPLIER where used in this document shall mean the party, who manufactures or supplies the equipment and services specified.

The INSPECTOR / TPIA / TPI where used in this document shall mean the PURCHASER / COMPANY or their authorized Third Party Agency for carrying out the inspection.

The PMC where used in this specification shall mean the party, who perform Project Management for COMPANY.



### 3.2 ABBREVIATION

CEA	:	Central Electricity Authority
CIMFR	:	Central Institute of Mines & Fuel Research
DGMS	:	Director General of Mines & Safety
FM	:	Factory Mutual Research Corporation
IEC	:	International Electro technical Commission
LCIE	:	Laboratories Central des Industries Electriques
MOV	:	Motor operated valve
PESO	:	Petroleum and Explosives Safety Organization
PVC	:	Poly Vinyl Chloride
UL	:	Underwriters Laboratory

### 4. GENERAL REQUIREMENTS

- 4.1. The offered equipment shall be brand new with state of art technology and proven field track record. No prototype equipment shall be offered.
- 4.2. Intelligent, microprocessor based, non-intrusive for configuration & local/remote control, digital display, electronic torques, contactless position sensing of actuator limits.
- 4.3. Suitable for use on nominal 415 volt 3 phase 50Hz power supply.
- 4.4. The actuator shall include a device to ensure that the motor runs with the correct rotation for the required direction of valve travel irrespective of the connection sequence of the power supply.
- 4.5. Vendor shall ensure availability of spare parts and maintenance support services for the offered equipment at least for 15 years from the date of supply.



	<b>MRPL Marketing Terminal Project at Devangonithi, Bangalore</b> <b>Marketing Infrastructure Projects, MRPL</b>				
	<b>Part - E</b>	<b>STANDARD SPECIFICATION FOR ELECTRICAL MOTOR OPERATED VALVE ACTUATORS</b>	Tender No.:		3200000495
	<b>Section – E-7</b>		Doc. No. :		20005-GEN-E-SPE-5011
<b>Subsection – E-7.11</b>	Rev :		01		

- 4.6. Vendor shall give a notice of at least one-year to the end user of equipment and PMC / COMPANY before phasing out the product/spares to enable the end user for placement of order for spares and services.
- 4.7. The vendor shall be responsible for design, engineering and manufacturing of the complete actuator to fully meet the intent and requirements of this specification and attached data sheets if any.

## 5. SITE CONDITIONS

The electrical motor operated valve actuators shall be suitable for operating under site conditions as specified in the requisition and data sheet / project details. If not specifically mentioned therein, a design ambient temperature of 40°C and an altitude not exceeding 1000m above mean sea level shall be considered.

## 6. POWER SUPPLY

The electrical motor operated valve actuators shall be suitable for power supply at 415V $\pm$  10%, 50 Hz  $\pm$  3%, 3 phase, unless specified otherwise in the data sheet.

## 7. TECHNICAL SPECIFICATIONS

Each MOV actuator shall include the motor, actuator unit, gears, position indicators, limit switches, hand wheel, electrical starter and controls, terminal box etc. as a self-contained unit. The actuator shall be sized to provide adequate torque and/ or thrust to ensure the complete intended travel of the valve under the worst operating and electrical power supply conditions.

MOV's shall be provided with integral starters and intelligent type (IQ range model of ROTORK make or equivalent).

In order to maintain the integrity of the actuator enclosure, setting of Torque Levels, Position Limits, configuration of Indication contacts etc shall be carried out without removal of any actuator cover and irrespective of availability of main power supply to actuator and this should be feasible with support of internal battery/ Stored energy device.



### 7.1 MOTOR

- 7.1.1. The motor shall be 3-phase squirrel cage induction type unless specified otherwise in the data sheet. It shall have totally enclosed non-ventilated and surface cooled construction.

7.1.2. For direct quarter turn drive actuators, DC motor is accepted. However the actuator should accept main power supply of 3 Phase 415 V  $\pm$  10% variation AC at 50 Hz frequency with  $\pm$  5% variation and should have inbuilt AC to DC converters.

- 7.1.3. The motor shall be designed for valve actuator service with high starting torque and shall be suitable for Direct on line starting. It shall be rated for S2-15 minute duty and shall conform to IS-60034- 1 or equivalent international standards.

- 7.1.4. The actuator assembly shall be provided with Thermostat(s)/thermistor(s) embedded in it to achieve protection of motor against over-temperature.

	<b>MRPL Marketing Terminal Project at Devangonhi, Bangalore</b> <b>Marketing Infrastructure Projects, MRPL</b>				
	<b>Part - E</b>	<b>STANDARD SPECIFICATION FOR ELECTRICAL MOTOR OPERATED VALVE ACTUATORS</b>	Tender No.:		3200000495
	<b>Section – E-7</b>		Doc. No. :		20005-GEN-E-SPE-5011
	<b>Subsection – E-7.11</b>		Rev :		01

- 7.1.5. The motor shall be suitable for starting under required torque with 75% of rated voltage at motor terminals.
- 7.1.6. The motor shall have Class 'F' insulation with temperature rise limited to Class 'B' limits. Motor winding shall be treated to resist corrosive agents and moisture.
- 7.1.7. Motor rotor shall preferably be of die-cast aluminum and, if brazed, shall be free from phosphorous.
- 7.1.8. Motor installed in actuator shall be rated for minimum of 60 starts/stop per hour. This is minimum requirement of actuator envisaged for ON-OFF duty only.

## 7.2 INTEGRAL STARTER AND CONTROL TRANSFORMER

The reversing starter, control transformer and local controls shall be integral with the valve actuator, unless specified otherwise in the data sheet. Solid state control of valve actuator and electrically isolated interface for remote control requirement shall be provided, wherever these features exist in manufacturer's design.

The integral starter shall be supplied with the following devices:-

- Electrically and mechanically interlocked reversing contactors for opening and closing operations
- Control transformer with necessary tapping and protected with suitable easily replaceable fuses
- Terminal block for external cable connection fully prewired for internal devices of valve actuator.
- MOV Actuators operating with AC power supply shall be provided with automatic phase correction feature.

## 7.3 INTEGRAL PUSH BUTTON, SELECTOR SWITCHES, INDICATIONS AND CONTROL DEVICES



The following local control devices shall be provided integral with the MOV actuator.

- Push buttons for 'Opening/ Closing/ Stop' or alternatively 'Open/ Close' selector switch
- 'Local/ Off/ Remote' selector switch, pad-lockable in each position
- The actuator local display shall digitally indicate valve position from fully open to fully close in % increments. Opened, Closed and Intermediate position shall be included on the indicator. The digital display, without backlighting shall be maintained and updated during hand wheel operation when all external power to the actuator is isolated. The display shall incorporate valve, actuator and control status indication.



## 7.4 TORQUE AND TRAVEL LIMIT SWITCHES

Torque limit switches shall be provided to protect the motor from over-loading by cutting-off the power supply to motor during opening and closing operations. The limit switches shall be preset. However, it shall be possible to set the value of maximum torque during closing from 50% to 100% of rated torque of actuators. Travel limit switch shall be provided to cut-off the power supply to the motor at the end of preset limit of valve travel.

	<b>MRPL Marketing Terminal Project at Devangonhi, Bangalore</b> <b>Marketing Infrastructure Projects, MRPL</b>				
	<b>Part - E</b>	<b>STANDARD SPECIFICATION FOR ELECTRICAL MOTOR OPERATED VALVE ACTUATORS</b>	Tender No.:		3200000495
	<b>Section – E-7</b>		Doc. No. :		20005-GEN-E-SPE-5011
<b>Subsection – E-7.11</b>	Rev :		01		

Magnetic pulse type / Hall Effect Sensor / Equivalent Sensor with battery backup/Stored energy device to be used for Position Measurement. Mechanical Limit Switches for Position Measurement is not acceptable.

Measurement of torque shall be from direct measurement of force at the output of the actuator. Piezo Sensors / Equivalent Sensors to be used for Torque Measurement of multi turn actuators.

For direct quarter turn drive actuators, methods of determining torque-using data derived from the motor such as motor speed, current, flux etc are also acceptable subject to the precision and reliability of the torque measurement being better or at least equivalent to direct torque measurement principle.

Settings storage shall be in non-volatile memory and shall not get erased when power source is cut off or battery drains out

## 7.5 ENCLOSURES

Enclosures shall be flameproof and weatherproof suitable for gas group IIA, IIB and/ or II-C Ex-d with minimum T-3 Temperature rating and suitable for Zone -2 temperature applications. Actuator's shall be O-ring sealed, water tight to IP 68 and shall at same time have an inner water tight and dustproof O ring seal between the terminal component and the internal electrical elements of the actuator. The motor and all other internal electrical elements of the actuator shall be protected from Ingress of moisture and dust when the terminal cover is removed for site for cabling. Enclosure must allow for temporary site storage without need of electrical supply connection. Conformance certificate issued by recognized independence electrical test house like ATEX/CIMFR/BASEEFA/IECEX/LCIE/CENELCE/FM Shall be submitted.



All indigenous shall be confirm to Indian standards and shall have been tested and certified by Indian testing agencies. All indigenous and imported items shall also have valid statutory approvals as applicable for the specified hazardous locations from petroleum and explosive safety organizations (PESO)/CSE or any other applicable statutory authority.

## 7.6 CONTROL FACILITIES

The internal controls and monitoring circuits shall be incorporated within the integral starter along with transformer and control unit of valve actuator.

Remote control facility shall be provided as a standard feature. The remote control circuits shall be powered from internally derived control supply voltage. Common status contact indicating the availability of the MOV actuator for remote control shall be provided by monitoring the following:-

- Loss of one or more phases of power supply
- Loss of control circuit supply
- Selector switch in local mode
- Local stop push button set to 'OFF'
- Motor thermostat tripped
- Any other local fault/abnormal condition.

	<b>MRPL Marketing Terminal Project at Devangonhi, Bangalore</b> <b>Marketing Infrastructure Projects, MRPL</b>				
	<b>Part - E</b>	<b>STANDARD SPECIFICATION FOR ELECTRICAL MOTOR OPERATED VALVE ACTUATORS</b>	Tender No.:		3200000495
	<b>Section – E-7</b>		Doc. No. :		20005-GEN-E-SPE-5011
<b>Subsection – E-7.11</b>	Rev :		01		

Where applicable, one number hand-held infrared/blue tooth remote programming device required for site commissioning and reconfiguring (without the need of removal of the MOV cover) shall be supplied for each group of 10 valve actuators (subject to minimum one infrared/Bluetooth remote setting device, even if number of valve actuators are less than ten).

## 7.7 INTERFACE WITH OWNER'S PLC / DCS / REMOTE PUSH BUTTON STATION

Potential free contacts for the following shall be provided in actuator assembly for hardwire interface with Owner's DCS/PLC and/or Remote Push Button station: -

- a) Run indication
- b) Trip indication — 1 Nos.
- c) Open status — 1 Nos.
- d) Close status — 1 Nos.
- e) Ready to start indication
- f) Torque high indication
- g) Thermostat status.
- h) Open command — 1 Nos.
- i) Close command — 1 Nos.
- j) Local/Remote



In the event of voltage dips/power outage, status of MOVs (OPEN/ CLOSE indication) for remote annunciation shall not undergo any change. The wiring for all MOV's feedback controls shall be fail safe type. Any backup for power supply & hardware required for achieving the same shall be provided by vendor within the actuator. Owner shall not provide any power supply other than 415V±10%, three phase, and 50Hz ±3% incoming supply to each of "MOV Actuator".

Contacts shall be provided which can be selected to indicate any position of the actuator. Provisions shall be made for the selection of a normally closed or open contact form. Contacts shall maintain and update the position indication during manual hand wheel operation with or without support of internal battery/stored energy device when all external power to the actuator is isolated.





## 7.8 DATA LOGGER



Actuator should have inbuilt data logger which will store Actuator Configuration as well as events log. Data log should be possible to be downloaded independent of 2 wire communication system.

The data log file should be downloadable from Actuator data logger by PESO certified Intrinsically Safe PDA/ configuration tool. Required PESO certified PDA/ configuration tool (1 per 10 no's of actuator) and software for transferring of data so captured & accessing the data logged files should be supplied by vendor.

	<b>MRPL Marketing Terminal Project at Devangonhi, Bangalore</b> <b>Marketing Infrastructure Projects, MRPL</b>				
	<b>Part - E</b>	<b>STANDARD SPECIFICATION FOR ELECTRICAL MOTOR OPERATED VALVE ACTUATORS</b>	Tender No.:		3200000495
	<b>Section – E-7</b>		Doc. No. :		20005-GEN-E-SPE-5011
<b>Subsection – E-7.11</b>	Rev :		01		

## 7.9 HAND OPERATION

A hand wheel with hand/auto lockable lever shall be provided for emergency operation of the MOV. The energization of the motor shall automatically re-engage power operation.

## 7.10 TWO-WIRE CONTROL SYSTEM

The MOV actuators shall be suitable for 2-wire control system working. These actuators shall have general purpose FCU card embedded for communicating with any make of master station/DCS or the FCU shall also be compatible for direct communication on open type international standard 2 wire serial Modbus RTU protocol on RS485.

These actuators shall have individual field units connectable to a master station/DCS through a single 2-core cable for control and monitoring of the MOV's. The vendor shall indicate the maximum number of field units that can be connected to a master station/PLC/DCS and the maximum distance from the field unit to the master station /PLC/DCS. The vendor shall also indicate maximum number of control inputs and control/ status outputs from each field unit that can be handled through the 2-wire control system.

Each field unit/MOV actuator shall be addressable from the master station/DCS through a unique address code. All the field settable/adjustable parameters of the MOV actuator shall be settable from the master station/DCS. Similarly, all the indications available on the MOV actuator shall be available at the master station/DCS. Full diagnostic features for the MOV actuators shall be available for display.

FCU Modbus communication card shall be provided for only those actuators for which requirement is mentioned in scope of work.

## 7.11 DIGITAL CONTROL SYSTEM



Electric actuator shall be provided with an integrally mounted device providing digital connectivity with Owner's PLC/DCS for actuator control, status indication & monitoring. In this case, master station is not required any more. The control device shall meet the appropriate recognized protocol or BIS standards. Selection of protocol shall be as per data sheet only. Typical protocol/buses include:-

- Modbus RTU
- Profibus DP
- Device Net

Terminal for hardwired communication shall also be provided in addition to digital communication facility.

## 7.12 REMOTE POSITION INDICATOR

If requirement of remote position indication is specified in the data sheet, a 4-20 mA remote position transmitter shall be provided in the valve actuator which can be connected to user's PLC/ DCS. The remote position indicator shall continuously indicate the position of travel of the valve.

	<b>MRPL Marketing Terminal Project at Devangonhi, Bangalore</b> <b>Marketing Infrastructure Projects, MRPL</b>				
	<b>Part - E</b>	<b>STANDARD SPECIFICATION FOR ELECTRICAL MOTOR OPERATED VALVE ACTUATORS</b>	Tender No.:	3200000495	
	<b>Section – E-7</b>		Doc. No. :	20005-GEN-E-SPE-5011	
<b>Subsection – E-7.11</b>	Rev :		01		

### 7.13 NAMEPLATE

Each motorized valve actuator shall be provided with a stainless steel nameplate furnishing the following details, at a place convenient for reading. The nameplates shall be riveted/ fixed with screws and not pasted.

- a) Actuator tag number as per data sheet
- b) Motor kW rating, motor short time rating, motor supply voltage, nominal motor phase current, auxiliary switch rating
- c) Maximum torque setting
- d) Actuator enclosure type, Lubricant type
- e) Actuator type, wiring diagram number/catalogue number, actuator serial number.
- f) Wherever applicable, Hazardous area certification details which shall include details of the testing agency (CIMFR or equivalent), test certificate number with date, statutory approval number with date, approval agency (PESO / DGMS), BIS license number with date, applicable Gas group and Temperature class etc.,



### 7.14 WIRING AND TERMINALS

All devices provided in the actuator shall be wired up to the terminal block. The contacts for remote operation and indication shall also be wired up to the terminal block. Minimum 10% spare terminals shall be provided for future interlocks. Internal wiring for power and control circuits shall be appropriately sized for MOV actuator rating. Each wire shall be identified at both ends using PVC females. The terminal compartment shall be separated from the inner electrical components of the actuator by means of a water tight seal so that the actuator electrical components are protected from the ingress of moisture and foreign materials when the terminal cover is removed during installation and maintenance.

The actuator shall be provided with minimum five adequately sized cable entries viz., one for power cable and two for control cables. However, the actual number of control cable entries in actuators with 2-wire control system shall be provided based on job requirements as specified in data sheets/specification for control systems for MOV's. Suitable double compression cable glands shall be provided with each actuator for all cable entries and sealing plugs for all control cable entries. The cable glands and plugs shall be made of Nickel-plated brass. Plastic plugs shall not be acceptable. Cable sizes shall be informed during detailed engineering and actuator shall be provided with suitable arrangement for termination these sizes.

## 8. EQUIPMENT FOR CLASSIFIED HAZARDOUS AREAS

- 8.1. Actuators meant for hazardous areas shall meet the requirements of IS/IEC 60079 or equivalent international standards and shall be suitable for Gas groups and Temperature class as specified in the data sheet. Gas group IIB and Temperature class T3 (200°C) shall be considered if not indicated in data sheet. The manufacturer shall possess valid test certificates issued by a recognized independent test house (ATEX /CENELEC /CIMFR /BASEEFA /LCIE /UL /FM or equivalent) for the offered actuators. All indigenous equipment shall conform to Indian standards and shall have been tested and certified by Indian testing agencies. All equipment (indigenous and imported) shall also have valid statutory approvals as applicable for the specified hazardous locations from Petroleum and Explosives Safety Organization (PESO / DGMS) or any other

	<b>MRPL Marketing Terminal Project at Devangonhi, Bangalore</b> <b>Marketing Infrastructure Projects, MRPL</b>				
	<b>Part - E</b>	<b>STANDARD SPECIFICATION FOR ELECTRICAL MOTOR OPERATED VALVE ACTUATORS</b>	Tender No.:		3200000495
	<b>Section – E-7</b>		Doc. No. :		20005-GEN-E-SPE-5011
<b>Subsection – E-7.11</b>	Rev :		01		

applicable statutory authority. All indigenous flameproof equipment shall have valid BIS license and corresponding marking as required by statutory authorities.

8.2. The actuator accessories used shall be flame proof and suitable for hazardous area of Zone 2, Group IIA/IIB, T3 or better for applications. Additionally, all valve associated instruments shall be weather-proof to IP65/IP67 Instruments certified for use in the specified hazardous area classification shall be recognized by authority like FM, CENELEC, PTB, BASSEFA, ATEX, CCOE/PESO etc.

## 9. FIRE PROOFING



- 9.1. Electric actuators shall be provided with fire proofing if specified in data sheet. The fire proofing shall be rated for 30 minutes. Unless otherwise specified in the datasheet, fire proofing shall be provided by intumescent paint only (K- Mass/ERS/equivalent). The required certificates for the fireproof rating shall be furnished from an independent test laboratory.
- 9.2. MOV Actuators with fireproofing shall be suitable for termination of mica insulated fire survival type power and control cables.
- 9.3. Fire Proofing shall be done in actuators as per applicable OISD/PNGRB/Statutory requirement.

## 10. INSPECTION, TESTING AND ACCEPTANCE

- 10.1 The equipment shall be subject to inspection by Owner or by an agency authorized by the owner. Manufacturer shall finish all necessary information concerning the supply to Owner's inspector. During the course of manufacturing, the purchaser or his authorized representative shall be free to visit the works and assess the progress of work and the manufacturer shall render him all possible assistance to do so.
- 10.2 Following routine tests shall be carried out at the manufacturer's works under his supervision and at his own cost for all the actuators:-
  - 10.2.1. Functional and calibration test for torque and limit switches
  - 10.2.2. Response time test
  - 10.2.3. Variation of supply voltage
  - 10.2.4. Variation of frequency
  - 10.2.5. Test on output shaft at 100°C torque
  - 10.2.6. Tests for motor {As per relevant IS/IEC}
- 10.3 Following type test certificates of offered model of actuator shall be submitted for review & approval:-
  - 10.3.1. Life test
  - 10.3.2. Test on motor terminal box
  - 10.3.3. Damp heat recycling test

Two weeks' notice shall be given to Owner for witnessing the final testing of the complete assembly to ensure satisfactory operation of the MOV actuators. Type test certificates shall be



	<b>MRPL Marketing Terminal Project at Devangonhi, Bangalore</b> <b>Marketing Infrastructure Projects, MRPL</b>				
	<b>Part - E</b>	<b>STANDARD SPECIFICATION FOR ELECTRICAL MOTOR OPERATED VALVE ACTUATORS</b>	Tender No.:	3200000495	
	<b>Section – E-7</b>		Doc. No. :	20005-GEN-E-SPE-5011	
<b>Subsection – E-7.11</b>	Rev :		01		

furnished during detailed engineering. Final acceptance of MOVs at site shall be subject to successful testing of the MOV actuators with the valves.

- 10.4 Type test certificates, original drawings referred in certificates and statutory approval certificates and BIS license, where applicable, shall be shown to the inspection agency on demand. The certificates and BIS license must be valid at the time of dispatch.
- 10.5 Test certificates of bought-out components shall be shown to the inspection agency on demand.

#### 11. SPARE PARTS

Vendor shall furnish a list of recommended spares for two (2) years of trouble free and satisfactory trouble free operation, indicating the itemized price of each item of the spares.

#### 12. QUALITY ASSURANCE

Manufacturer shall follow his standard procedures for Quality Assurance and control. However, the standard procedures shall be submitted to the owner in extent of order.

The procedure shall be in such a form as to clearly delineate the manufacturing sequence and major inspection points and to reference manufacturer's test and inspection procedures.

The owner will inform the manufacturer as to which of the Inspection points and tests will be witnessed.

#### 13. GUARANTEE

Guarantee shall be for proper design, installation and workmanship. Vendor / contractor shall guarantee all performance parameters. The guarantee shall be for a period of 12 months from the date of commissioning or 18 months from the date of last supply whichever is earlier.

#### 14. PACKING AND DESPATCH



All the equipment shall be divided into multiple sections for protection and ease of handling during transportation. The equipment shall be properly packed for the selected mode of transportation, i.e. by ship, rail or trailer. The equipment shall be wrapped in polythene sheets before being placed in crates/ cases to prevent damage to finish. The crates/ cases shall have skid bottoms for handling. Special notations such as 'Fragile', 'This side up', 'Center of gravity', 'Weight', 'Owner's particulars', 'PO no.' etc., shall be clearly and indelibly marked on the packages together with other details as per purchase order.

The equipment may be stored outdoors for long periods before installation. The packing shall be completely suitable for outdoor storage in areas with heavy rains and high ambient temperature unless otherwise agreed. In order to prevent movement of equipment/components within the crates, proper packing supports shall be provided. A set of instruction manuals for erection, testing and commissioning, a set of operation & maintenance manuals and a set of final drawings shall be enclosed in a waterproof cover shall be supplied along with the shipment.

#### 15. SUPERVISION OF INSTALLATION & COMMISSIONING OF ACTUATOR



Supervision of installation & commissioning should be necessarily done in the presence of Actuator OEM's Engineer.

	<b>MRPL Marketing Terminal Project at Devangonhi, Bangalore</b> <b>Marketing Infrastructure Projects, MRPL</b>				
	Part - E	<b>STANDARD SPECIFICATION FOR IMPRESSED CURRENT CATHODOIC PROTECTION SYSTEM FOR PIPELINES</b>	Tender No.:	3200000495	
	Section – E-1		Doc. No. :	20005-GEN-E-SPE-5020	
Subsection –E-1.13	Rev :		0		

<b>E - 1</b>	<b>STANDARD SPECIFICATION</b>
<b>E - 1.13</b>	<b>IMPRESSED CURRENT CATHODOIC PROTECTION SYSTEM FOR PIPELINES</b>

## MRPL Marketing Terminal Project at Devangonhi, Bangalore



**PROJECT : MARKETING INFRASTRUCTURE PROJECTS, MRPL**

**OWNER : MANGALORE REFINERY AND PETROCHEMICALS LTD**

**PMC : NAUVATA ENGINEERING PVT. LTD.**



**JOB NO. : JBG20005**

0	10-02-2021	ISSUED FOR BID	ABN	MKV	MKV
C1	09-02-2021	ISSUED FOR REVIEW/COMMENTS	ABN	MKV	MKV
<b>Rev. No</b>	<b>Date</b>	<b>Purpose</b>	<b>Prepared by</b>	<b>Checked by</b>	<b>Approved by</b>



		<b>MRPL Marketing Terminal Project at Devangonhi, Bangalore</b> <b>Marketing Infrastructure Projects, MRPL</b>				
		Part - E	<b>STANDARD SPECIFICATION FOR IMPRESSED CURRENT CATHODIC PROTECTION SYSTEM FOR PIPELINES</b>	Tender No.:		3200000495
		Section – E-1		Doc. No. :		20005-GEN-E-SPE-5020
Subsection –E-1.13	Rev :	0				

## TABLE OF CONTENTS

<b>1. SCOPE</b> .....	4
<b>2. APPLICABLE CODES AND STANDARDS</b> .....	4
<b>3. SYSTEM IMPLEMENTATION</b> .....	5
<b>4. CORROSION SURVEY</b> .....	5
4.1. General.....	5
4.2. Soil Resistivity Survey at Impressed Current Anode Ground Bed Plot.....	6
4.3. Topographic Surveys .....	6
4.4. Additional Data to be collected .....	6
4.5. Report.....	7
<b>5. CATHODIC PROTECTION DESIGN PARAMETERS</b> .....	7
5.1. Protection Current Density Range .....	8
<b>6. CATHODIC PROTECTION DESIGN CRITERIA</b> .....	9
<b>7. SYSTEM DETAILS</b> .....	9
7.1. Cathodic Protection Stations.....	10
7.2. CP Transformer Rectifier Unit/ CPPSM .....	11
7.3. Anode Ground Beds.....	11
7.4. Anode Junction Box .....	12
7.5. Cathode Junction BoX .....	12
7.6. Test Stations.....	12
7.7. Permanent Reference Cells.....	14
7.8. Polarisation Cell and Surge Diverter .....	14
7.11. Polarisation Coupons.....	15
7.12. CP at Cased Crossing .....	16
7.13. Reference Cell Access Points .....	16

	<b>MRPL Marketing Terminal Project at Devangonthi, Bangalore</b> <b>Marketing Infrastructure Projects, MRPL</b>				
	Part - E	<b>STANDARD SPECIFICATION FOR IMPRESSED CURRENT CATHODOIC PROTECTION SYSTEM FOR PIPELINES</b>	Tender No.:		3200000495
	Section – E-1		Doc. No. :		20005-GEN-E-SPE-5020
Subsection –E-1.13	Rev :		0		

7.14.	Cables .....	16
<b>8.</b>	<b>INSTALLATION .....</b>	<b>17</b>
8.1.	Cable Laying.....	17
8.2.	Permanent Reference Cells.....	17
8.3.	Cable to Pipe Connections.....	17
8.4.	Ground Bed Fencing .....	18
<b>9.</b>	<b>FIELD TESTING AND COMMISSIONING .....</b>	<b>18</b>
9.1.	System Testing at Site .....	18
9.2.	CP Commissioning Procedure .....	20
<b>10.</b>	<b>INTERFERENCE MITIGATION .....</b>	<b>22</b>
<b>11.</b>	<b>CLOSE INTERVAL POTENTIAL SURVEY .....</b>	<b>23</b>

	<b>MRPL Marketing Terminal Project at Devangonhi, Bangalore</b> <b>Marketing Infrastructure Projects, MRPL</b>				
	Part - E	<b>STANDARD SPECIFICATION FOR IMPRESSED CURRENT CATHODOIC PROTECTION SYSTEM FOR PIPELINES</b>	Tender No.:		3200000495
	Section – E-1		Doc. No. :		20005-GEN-E-SPE-5020
	Subsection –E-1.13		Rev :		0



## 1. SCOPE

- 1.1. This specification defines the requirements of system design, engineering, installation, testing and commissioning of an Impressed Current Cathodic Protection System for cross-country onshore underground pipelines/ structures including supplementing of corrosion survey, close interval potential logging survey, investigations for interaction/interference problems and mitigation of the same.
- 1.2. This specification provides the basic parameters to develop a suitable impressed current cathodic protection system for the pipelines/ structures requiring protection. All data required in this context shall be taken into consideration to develop an acceptable design and for proper engineering of the system.
- 1.3. Compliance with these specifications, and/or approval of any documents submitted by contractor shall be in no case relieve the contractor of his contractual obligations.

## 2. APPLICABLE CODES AND STANDARDS

- 2.1. The system design, performance and materials to be supplied shall conform to the requirements of the latest revision of following standards as a minimum.

NACE Standard SP0169	Control of External Corrosion on Underground or Submerged Metallic Piping Systems
NACE Standard TM0497	Measurement Techniques Related to Criteria for Cathodic Protection on Underground or Submerged Metallic Piping Systems
NACE Standard SP0177	Mitigation of Alternating Current and Lightning Effects on Metallic Structures and Corrosion Control Systems
NACE Standard SP0286	Electrical Isolation of Cathodically Protected Pipelines
NACE Publication No. 54276	Cathodic Protection Monitoring for Buried Pipelines
NACE Standard SP0572	Design, Installation, Operation and Maintenance of Impressed Current Deep Ground beds
DNV-RP-B401	Cathodic Protection Design
IS 8062	Recommended Practice- ICCP for Underground Piping
BS 736 I Part 1	Cathodic Protection- Code of Practice for Land and Marine Applications
VDE 0150	Protection against Corrosion due to Stray Current from DC

	<b>MRPL Marketing Terminal Project at Devangonhi, Bangalore</b> <b>Marketing Infrastructure Projects, MRPL</b>				
	Part - E	<b>STANDARD SPECIFICATION FOR IMPRESSED CURRENT CATHODIC PROTECTION SYSTEM FOR PIPELINES</b>	Tender No.:		3200000495
	Section – E-1		Doc. No. :		20005-GEN-E-SPE-5020
	Subsection –E-1.13		Rev :		0

	Installations
IS 1554 Part 1	PVC Insulated (Heavy Duty) Cables
IS/ IEC: 60079	Electrical Apparatus for Explosive Gas Atmosphere
IS/ IEC: 60529	Classification of Degree of Protection Provided by Enclosures

- 2.2. In case of imported equipment's standards of the country of origin shall be applicable if these standards are equivalent or stringent than the applicable Indian standards.
- 2.3. The equipment shall also conform to the provisions of Indian Electricity rules and other statutory regulations currently in force in the country.
- 2.4. In case of any contradiction between various referred standards/ specifications/ data sheet and statutory regulations the following order of priority shall govern:
  - Statutory Regulations/Data Sheets
  - Job Specification
  - This Specification
  - Codes and Standards

### 3. SYSTEM IMPLEMENTATION



All work to be performed and supplies to be effected as a part of contract shall require specific review by Owner or his authorized representative. Major activities requiring review shall include but not be limited to the following:

- i) Corrosion survey data interpretation report and plot plans for land acquisition
- ii) Conceptual system design
- iii) Basic engineering package
- iv) Detailed engineering package
- v) Field testing and commissioning procedures
- vi) Procedures for interference testing and mitigation
- vii) Close interval potential logging survey procedure
- viii) As built documentation

### 4. CORROSION SURVEY

#### 4.1. GENERAL

- 4.1.1. The details of corrosion survey including soil resistivity data along ROU and other data required for C.P design if available with the Owner shall be included as part of project specification/ data sheet. However, verification of its veracity and adequacy shall be the entire responsibility of the contractor. In addition, contractor shall have to generate/ collect additional data as per

	<b>MRPL Marketing Terminal Project at Devangonhi, Bangalore</b> <b>Marketing Infrastructure Projects, MRPL</b>				
	Part - E	<b>STANDARD SPECIFICATION FOR IMPRESSED CURRENT CATHODIC PROTECTION SYSTEM FOR PIPELINES</b>	Tender No.:		3200000495
	Section – E-1		Doc. No. :		20005-GEN-E-SPE-5020
	Subsection –E-1.13		Rev :		0

clause 4.4 below required for completeness of the job.

Contractor shall carry out soil resistivity survey at anode ground bed locations for design of ground bed. Where specified in the data sheet, Contractor shall carry out corrosion survey along the ROU of the pipeline conforming to the specifications included in the tender document.

- 4.1.2. To carry out soil resistivity measurement Wenner's 4-pin method or an equivalent method approved by Owner/ Owner's representative shall be used. Survey instruments shall have maximum AC and DC ground current rejection feature.

Care shall be taken to ensure that the resistivity observations are not influenced by the presence of foreign pipelines/ structures, and earth currents in the vicinity of EHV/ HV lines and installations using earth return in their power system etc.

#### **4.2. SOIL RESISTIVITY SURVEY AT IMPRESSED CURRENT ANODE GROUND BED PLOT**

- 4.2.1. Each selected anode bed plot shall be sub-divided into sub-plots. Sizes of sub-plots shall depend upon the expected depth for soil resistivity investigations. Each of these sub-plots shall be investigated for resistivity data individually. Sufficient observations shall be taken at each of these sub-plots as required and desired by Owner/ Owner's representative to obtain sufficient information about sub-soil stratification and, wherever possible, to establish the depth of water table. The number of subplots at each ground bed plot shall be decided at site in consultation with Owner/ Owner's representative.
- 4.2.2. Number, location, demarcation and size of sub-plots and number of sets of resistivity observations required for each sub-plot shall & individually decided for each ground bed plot location.
- 4.2.3. One or more ground bed plots may be required to be selected and surveyed at each CP station to form a suitable ground bed.



#### **4.3. TOPOGRAPHIC SURVEYS**

Cathodic protection stations consisting of anode ground bed, CP station etc. as applicable, along with all associated cabling up to pipeline and any other related equipment and accessories for CP station shall be demarcated on the ground. Ground plots so demarcated shall be surveyed for all other topographical and cadastral features and topo-sheets shall be developed by the CONTRACTOR, which shall be suitable for use in land acquisition etc.

#### **4.4. ADDITIONAL DATA TO BE COLLECTED**

The following data shall be collected to generate design data for evaluation of interaction/interference possibilities due to presence of other services in ROU or in its vicinity. OWNER shall provide assistance for liaison work to the extent possible.

- 1) Route and types of Foreign Service/ pipeline in and around or crossing the right of use (including those existing and those which are likely to come up during contract execution).
- 2) Diameter, wall thickness, pressure, soil cover, and coating scheme used, type of cathodic protection system provided, if any, year of laying/ commissioning in case of foreign

	<b>MRPL Marketing Terminal Project at Devangonhi, Bangalore</b> <b>Marketing Infrastructure Projects, MRPL</b>				
	Part - E	<b>STANDARD SPECIFICATION FOR IMPRESSED CURRENT CATHODOIC PROTECTION SYSTEM FOR PIPELINES</b>	Tender No.:		3200000495
	Section – E-1		Doc. No. :		20005-GEN-E-SPE-5020
	Subsection –E-1.13		Rev :		0

pipelines.

- 3) Details of the existing cathodic protection systems protecting the services i.e. type of protection, location, type, rating of anode beds, test station locations and their connection schemes. Present output current and voltage readings of the CP power supply units.
- 4) Remedial measures existing on foreign pipelines/ services to prevent interaction.
- 5) Graphical representation of existing structure/ pipe-to-soil potential records.
- 6) Possibility of integration/ isolation of CP systems, which may involve negotiations with owners of other services.
- 7) Existing and proposed DC/AC power sources and systems using earth return path such as HVDC substations/ earthing stations, fabrication yards with electric welding etc. in the vicinity of the entire pipeline route.
- 8) Crossing and parallel running of electrified and non-electrified traction (along with information regarding, operating voltage, AC/DC type etc.) as well as abandoned tracks near ROU having electrical continuity with the tracks in use.
- 9) Crossing or parallel running of any existing or proposed EHV/HV AC/DC overhead power lines along with details of voltage, AC/DC type etc.
- 10) Voltage rating, phases, sheathing details of underground power cables along ROU or in its vicinity.
- 11) Any other relevant information that may be needed in designing and implementing proper cathodic protection scheme for the proposed pipeline.

Contractor shall conduct necessary potential gradient surveys for any existing anode ground beds that may interfere with the CP system of the pipelines covered under this project.

#### 4.5. REPORT



On completion of all field work, a report incorporating all the results generated from surveys and details of additional data collected shall be prepared. The report shall also contain detailed interpretation of survey results and resistivity data, probable interference prone areas, selected locations for anode ground beds etc., to form a design basis for the scheme of cathodic protection. This report shall also include various drawings prepared in connection with the above work. Soil resistivity values shall be plotted on semi-log graph sheets.

#### 5. CATHODIC PROTECTION DESIGN PARAMETERS

A distinctly independent impressed current cathodic protection system shall be provided to protect the external surfaces of the complete pipeline/ structure installation as specified.

Unless otherwise stated in the data sheets, the following parameters shall be used for design of permanent cathodic protection system:



	<b>MRPL Marketing Terminal Project at Devangonhi, Bangalore</b> <b>Marketing Infrastructure Projects, MRPL</b>				
	Part - E	<b>STANDARD SPECIFICATION FOR IMPRESSED CURRENT CATHODIC PROTECTION SYSTEM FOR PIPELINES</b>	Tender No.:		3200000495
	Section – E-1		Doc. No. :		20005-GEN-E-SPE-5020
	Subsection –E-1.13		Rev :		0

### 5.1. PROTECTION CURRENT DENSITY RANGE

- i) Pipe lines having Dual Layer Fusion Bonded Epoxy (DLFBE) coating or 3-Layer Polyethylene (3LPE) coating:



Minimum Protection Current Density*	
Temporary CP ( $\mu$ A/m <sup>2</sup> )	Permanent CP for 30-Year Design Life ( $\mu$ A/m <sup>2</sup> )
25	25 0

The above current density values for temporary CP system are applicable for CP system design life up to two years.

\*Actual current density to be adopted shall be decided based upon soil and other environmental conditions, current drainage survey data, proximity of foreign pipelines/structures and other interference areas affecting the installation. Where considered necessary for satisfactory protection of pipeline the current density shall be suitably increased by contractor. Also refer to clause 7.1 (iv) below.

For all pipeline sections which are having intermediate HDD (Horizontal Directional Drilling) crossings, the nearby T/R units should have adequate provision of D.C. output current to cater to the extra protection current demand at the HDD crossings.

- 5.2. The pipe protection Current Density indicated in the clause 5.1 above shall be applicable where the temperature of the fluid transported by the pipeline/ the surface temperature of the buried portion of the pipeline does not exceed 30 °C. Where this temperature exceeds 30 °C, the protection Current Density shall be increased in minimum by 25% for every 10 °C rise in temperature over 30 °C.
- 5.3. Safety factor for current density : 1.3
- 5.4. Anode utilization factor : 0.85 for center connected anode  
(For High Silicon Cast Iron Anode) : 0.6 for end connected anode
- 5.5. Anode surface current density  
(For High Silicon Cast Iron Anode : 15 Amp./sq.m for shallow anode for ground  
bed continuous operation) 10 Amp./sq.m for deep well anode  
ground bed  
(For MMO Coated Titanium Anode : 70 Amp./sq.m in coke backfill  
for continuous operation) : 30 Amp./sq.m in soil without coke backfill
- 5.6. Anode consumption rate

	<b>MRPL Marketing Terminal Project at Devangonhi, Bangalore</b> <b>Marketing Infrastructure Projects, MRPL</b>				
	<b>Part - E</b>	<b>STANDARD SPECIFICATION FOR IMPRESSED CURRENT CATHODIC PROTECTION SYSTEM FOR PIPELINES</b>	Tender No.:		3200000495
	<b>Section – E-1</b>		Doc. No. :		20005-GEN-E-SPE-5020
	<b>Subsection –E-1.13</b>		Rev :		0

(For High Silicon Cast Iron Anode) : 0.2 kg./Amp-yr

(For MMO Coated Titanium Anode) : 2.0 mg./Amp-yr (In Coke Backfill)

5.7. Pipeline natural potential : (-)0.45V

5.8. Design life of CP system : 25 years, unless specified otherwise in the data sheet

5.9. Anode ground bed loop resistance :  
including anode to ground resistance, 1 Ohm (max.)  
anode and cathode cable resistances

(The output voltage rating of the CPTR unit/ CPPSM shall in minimum be adequate to drive the specified end of life cathodic protection current with safety factor, considering the total anode ground bed loop resistance as the sum of the resistance specified in this clause and pipe to earth resistance).

## 6. CATHODIC PROTECTION DESIGN CRITERIA



Cathodic protection system shall be designed to meet the following criteria:

- i) The pipe to soil potential measurements shall be between (-) 0.9V (OFF) and (-) 1.18V (OFF) with respect to a copper/copper Sulphate reference electrode.
- ii) In rare circumstances, a minimum polarization shift of (-) 100 milli volts may be accepted as an adequate level of cathodic protection for the pipeline with the approval of Owner.
- iii) A positive potential swing of 100 millivolts or more shall be considered sufficient to indicate the presence of an interaction/ interference situation requiring investigation and incorporation of mitigation measures by the Contractor.

## 7. SYSTEM DETAILS

The system shall include the following major equipment/ sub-systems unless otherwise specified in project specifications:

- CP stations
- CPTR units/ cathodic protection power supply modules (CPPSM).
- Anode ground beds and anodes
- Anode junction box
- Cathode junction box
- Test stations
- Permanent reference cells
- Polarization cell and surge diverter
- Polarization coupons
- CP system at cased crossing
- Bond Stations
- Cables

	<b>MRPL Marketing Terminal Project at Devangonhi, Bangalore</b> <b>Marketing Infrastructure Projects, MRPL</b>				
	Part - E	<b>STANDARD SPECIFICATION FOR IMPRESSED CURRENT CATHODIC PROTECTION SYSTEM FOR PIPELINES</b>	Tender No.:		3200000495
	Section – E-1		Doc. No. :		20005-GEN-E-SPE-5020
	Subsection –E-1.13		Rev :		0

All equipment shall be new and procured from Owner's approved manufacturers. Equipment offered shall be field proven. Equipment requiring specialized maintenance or operation shall be avoided as far as possible. Prototype equipment shall not be accepted.

All equipment/ materials shall conform to the relevant specifications included in the tender document.

All equipment including CPTR unit, CPPSM, test stations, anode lead junction boxes etc. shall be located in safe non-hazardous areas.

Where it is essential to install electrical and electronic instrument enclosures and its accessories in hazardous area, such equipment shall be flame proof type and shall meet the requirements as per IS/ IEC: 60079 and shall be weather proof to IP-65 also as per IS/IEC:60529.



A copy of approval from local statutory authority, as applicable such as Petroleum & Explosives Safety Organization (PESO)/ Chief Controller of Explosives (CCE) or Director General of Mines Safety (DGMS) in India, for the electronic instruments installed in electrically hazardous area along with:

- i) Test certificate from recognized test house like Central Institute of Mining and Fuel Research (CIMFR)/ Electronics Regional Testing Laboratory (ERTL) etc. for flameproof enclosure/ intrinsic safety, as specified in the data sheet, as per relevant standard for all Indian manufactured equipment's or for items requiring Director General of Mines Safety (DGMS) approval.
- ii) Certificate of conformity from agencies like Laboratories Central Des Industries Electriques (LCIE), British Approval Service for Electrical Equipment in flammable Atmospheres (BASEEFA), Factory Mutual (FM), Physikalisch-Technische Bundesanstalt (PTB), Canadian Standards Association (CSA), Underwriters Laboratories (UL) etc. for compliance to ATEX directives or other equivalent standards for all equipment's manufactured outside India.

#### 7.1. CATHODIC PROTECTION STATIONS

The number and exact locations of CP stations shall be worked out based on the corrosion survey data collected. In addition, the following guidelines shall be followed for selecting the locations:

- i) Number of CP stations and their selected locations shall ensure that these remain valid and are adequate for the full design life of the system after considering all foreseeable factors.
- ii) As far as possible, the availability of nearby low resistivity areas for location of associated ground beds must be ensured while selecting the locations of CP stations.
- iii) As far as possible, locations of intermediate CP stations shall coincide with the locations of SV stations.
- iv) The proposed locations of CP stations and anode ground bed current ratings are detailed in project specifications/ data sheets. The same shall be verified for adequacy by the contractor. The requisite current drainage tests/ survey shall be conducted by the

	<b>MRPL Marketing Terminal Project at Devangonhi, Bangalore</b> <b>Marketing Infrastructure Projects, MRPL</b>				
	Part - E	<b>STANDARD SPECIFICATION FOR IMPRESSED CURRENT CATHODIC PROTECTION SYSTEM FOR PIPELINES</b>	Tender No.:		3200000495
	Section – E-1		Doc. No. :		20005-GEN-E-SPE-5020
	Subsection –E-1.13		Rev :		0

contractor to establish the adequacy of CP current requirement indicated in clause 5.0 above and adequacy of number, ratings of CP stations for permanent CP system indicated in the data sheet. The minimum end of life pipe protection current requirement shall be considered as the current requirement indicated in the clause 5.0 above or 3 times the current density value measured by the current drainage survey for polyethylene coated pipeline and 4 times the current density value measured by the current drainage survey for fusion bonded epoxy, coal tar enamel with reinforcement coated pipeline, whichever is maximum.

### 7.2. CP TRANSFORMER RECTIFIER UNIT/ CPPSM



If specified in project specifications/ data sheet, the supply, installation, testing and commissioning of cathodic protection power supply module (CPPSM)/ indoor type Cathodic Protection Transformer Rectifier Unit (CPTR unit)/ outdoor type CPTR unit installed in kiosk along with kiosk shall be included in contractor's scope. The CPTR units shall be provided at CP stations where reliable AC power supply is available. CPPSM shall be provided at other CP stations where reliable DC power supply instead of reliable AC power supply is available. The CPTR unit/ CPPSM shall be installed in non-hazardous (safe) area as specified in data sheets.

### 7.3. ANODE GROUND BEDS

- i) Each CP station shall have an independent anode ground bed, which may be of shallow or deep well construction depending upon the data collected by the contractor. Deep well ground beds may also be used in the congested locations where availability of suitable land for spread out ground beds is restricted.
- ii) Ground bed shall be located electrically remote from the pipeline and foreign pipeline/ other buried metallic structures. Nearest part of the anode bed shall at least be 100 meters away from the pipeline and foreign pipeline/ other buried metallic structures. The anodes installed in the ground shall be located in perennially moist strata, wherever possible. Horizontal ground beds shall be at right angles to the pipeline, as far as possible.

The location of ground bed shall be checked and ensured for remoteness from the pipeline and other buried foreign pipelines/ structures, building foundations, switchyards, electrical earthing systems, etc.

- iii) Unless otherwise agreed, anodes shall be of high silicon cast iron type or mixed metal oxide coated titanium anodes.
- iv) Sheet steel anode canisters of adequate size shall be provided for each anode. Anode canisters shall be filled with petroleum coke breeze. In case of deep well ground beds non-canistered anodes with petroleum coke breeze in the well surrounding the anodes shall be provided.
- v) Each shallow anode-bed shall contain anodes with canisters positioned horizontally or vertically in the soil with suitable backfill. The depth of anodes (depth of top of anode in case of vertically laid anodes) shall not be less than 2 meter from grade level.

	<b>MRPL Marketing Terminal Project at Devangonhi, Bangalore</b> <b>Marketing Infrastructure Projects, MRPL</b>				
	Part - E	<b>STANDARD SPECIFICATION FOR IMPRESSED CURRENT CATHODOIC PROTECTION SYSTEM FOR PIPELINES</b>	Tender No.:		3200000495
	Section – E-1		Doc. No. :		20005-GEN-E-SPE-5020
	Subsection –E-1.13		Rev :		0

- vi) Layout of anode installation in anode bed shall be detailed out in drawings showing anode installation details, anode grouping, anode wiring, anode cable routing, etc. The deep well anode ground bed details shall include the details of anodes, deep well casing, anode positioning, anode cable supporting, deep well gas venting, active, passive portions of the ground bed etc.
- vii) Anodes shall be supplied complete with tail cables, which shall be long enough for termination on their associated anode lead junction boxes without intermediate joints. Exact lengths and termination details shall be indicated in construction drawings.
- viii) Potential gradient around the anode bed shall be within safety requirements with regard to interference on foreign structures and its effective boundary shall be defined.
- ix) In case of two parallel pipelines running in the same ROU, the anode ground beds of the respective pipelines shall be located on the respective sides of the pipelines.

#### 7.4. ANODE JUNCTION BOX

Depending on the size and configuration of anode ground beds, one or more anode junction boxes shall be provided at each ground bed. All cable tails from individual anodes shall be terminated onto the respective anode junction boxes, which shall be further connected to the main anode junction box (where applicable). The main anode junction box shall be connected to the cable coming from CP power source. Each outgoing circuit in main junction box (where applicable) and each anode circuit in junction shall have provision for measurement and control of individual circuit/anode current.

#### 7.5. CATHODE JUNCTION BOX

Where output of the CP power supply unit is connected to multiple pipelines a cathode junction box shall be provided near the pipelines at the location of connection of the negative drainage cable to the pipelines.



The negative of the CP power source shall be connected to the incoming circuit of the cathode junction box. The junction box shall have separate out going circuit one for each pipeline to collect the negative drainage currents from each of the parallel pipelines.

The incoming circuit shall have a current measurement facility. Each out going circuits shall have provision for measurement and control of current.



#### 7.6. TEST STATIONS

- 7.6.1. Test stations shall be provided along the pipeline ROU for monitoring the performance of the cathodic protection system at the following locations. Test stations shall be provided at additional locations, if required, so that distance between any two adjacent test stations does not exceed 1000 meters in inhabited areas and 2000 meters in uninhabited areas like forest/deserts:

- 1) At all insulating joints
- 2) At both sides of metaled road crossings
- 3) At vulnerable locations with drastic changes in soil resistivity

	<b>MRPL Marketing Terminal Project at Devangonhi, Bangalore</b> <b>Marketing Infrastructure Projects, MRPL</b>				
	<b>Part - E</b>	<b>STANDARD SPECIFICATION FOR IMPRESSED CURRENT CATHODOIC PROTECTION SYSTEM FOR PIPELINES</b>	Tender No.:		3200000495
	<b>Section – E-1</b>		Doc. No. :		20005-GEN-E-SPE-5020
	<b>Subsection –E-1.13</b>		Rev :		0

- 4) At locations of surge diverters, pipeline grounding through polarization cells, Zinc and Magnesium anodes
  - 5) At EHV/HV AC/DC overhead line crossings and selected locations where EHV/HV overhead line is in the vicinity of the pipeline
  - 6) At railway line crossings and at selected locations along lines running parallel to the pipeline
  - 7) At both sides of major river crossings
  - 8) At EHV/HV cable crossings or along routes where EHV/HV cables are running in parallel
  - 9) In the vicinity of DC networks or grounding systems and HVDC grounding systems where interference problems are suspected
  - 10) At crossings of other pipeline's/ structures
  - 11) At the locations of reference cell and polarization coupon installation
  - 12) At both sides of cased crossings
  - 13) Locations where interference is expected
  - 14) At locations of sectionalizing valve (SV) stations
  - 15) At any other locations considered necessary by Owner/ Owner's representative
- 7.6.2. Test stations for bonding shall be provided with shunt and resistor as a means to monitor and control current flow between the pipeline and foreign pipelines or structures that may exist in common ROU.
- 7.6.3. Test stations with current measuring facility shall be provided at each CP station drainage point (to measure pipeline current on any one side of pipeline from drainage point at intermediate CP station and towards protected side of the pipeline at starting, end point CP stations), at interference prone areas, on both sides of major river crossings, near marshy areas and minimum one for every 10 km max. along the pipeline.
- 7.6.4. Test stations shall be installed with the face of the test station facing the pipeline. The nameplate of test stations shall carry the following minimum information:
- Chain age in km.
  - Test station connection scheme
  - Distance from pipeline in meter.
  - Direction of product flow.
- 7.6.5. Number of terminals and different schemes of wiring shall be as per the test station connection scheme. Minimum twenty percent spare terminals shall be provided in each test station.
- 7.6.6. Minimum two cables from the pipeline shall be provided at any test station.
- 7.6.7. The location of all the test stations shall be marked with their connection schemes and other

	<b>MRPL Marketing Terminal Project at Devangonhi, Bangalore</b> <b>Marketing Infrastructure Projects, MRPL</b>				
	Part - E	<b>STANDARD SPECIFICATION FOR IMPRESSED CURRENT CATHODIC PROTECTION SYSTEM FOR PIPELINES</b>	Tender No.:		3200000495
	Section – E-1		Doc. No. :		20005-GEN-E-SPE-5020
	Subsection –E-1.13		Rev :		0

relevant information on alignment sheets. A detailed test-station schedule shall be prepared.

#### 7.7. PERMANENT REFERENCE CELLS



- 7.7.1. High purity copper/copper Sulphate reference cells with proven high reliability shall be provided for stable pipe to soil potential measurement at CP stations and polarization coupons along ROU.
- 7.7.2. Silver/Silver Chloride reference cells in place of copper/copper Sulphate cells shall be provided at marshy area locations, where water table is high and chloride concentration is more than 300 ppm. For marshy area in saline soil, high purity Zinc may be considered as an alternative to silver/silver chloride. The test station connection scheme shall clearly indicate the type of the reference electrode (Cu CuSO<sub>4</sub> /Ag AgCl) at these locations.
- 7.7.3. The life of the reference cells shall be minimum 8 years under the installed conditions.
- 7.7.4. The cable from reference cells shall be provided up to CP power source at CP stations and up to test stations at the locations of polarization coupons. The cable up to CP power source shall be routed through test stations near pipeline.

#### 7.8. POLARISATION CELL AND SURGE DIVERTER

##### 7.8.1. Polarization Cell

- i) Wherever the pipeline is either crossing or running in parallel with overhead EHV/HV transmission lines of voltage grade 66kV and above, it is mandatory that the pipeline shall be grounded to discharge any accumulated potential/ surge that may appear in case of transmission line faults, as per below:
- The pipeline shall be grounded through polarization cell with Zinc galvanic anodes of either block anode or ribbon type. Sizing and quantity of anode shall be decided so as to achieve maximum total earth resistance of 5 Ohm for each location where pipeline crosses EHV/HV transmission lines.
  - The pipeline shall be grounded at regular intervals of maximum 1 km where EHV/HV transmission lines run parallel within 25m of the pipeline. Also, where EHV/HV transmission lines run parallel beyond 25 m of the pipeline and it is expected from calculations/ software simulations that surge would appear in case of transmission line faults or any abnormal operating conditions.
- ii) Locations along pipeline where continuous induced over-voltage due to other overhead transmission lines/ underground cables of voltage grade below 66kV is expected or observed during commissioning, the pipeline shall be grounded through polarization cell to the earth system of the EHV/HV tower causing the voltage induction or to a separate earthing system of Zinc anodes through polarization cell.
- iii) Polarization cell shall be installed inside test station of suitable size.
- iv) Type of polarization cell shall be as specified in data sheet.

##### 7.8.2. Surge Diverter

	<b>MRPL Marketing Terminal Project at Devangonhi, Bangalore</b> <b>Marketing Infrastructure Projects, MRPL</b>				
	Part - E	<b>STANDARD SPECIFICATION FOR IMPRESSED CURRENT CATHODIC PROTECTION SYSTEM FOR PIPELINES</b>	Tender No.:		3200000495
	Section – E-1		Doc. No. :		20005-GEN-E-SPE-5020
	Subsection –E-1.13		Rev :		0

Explosion proof spark gap surge diverter shall be provided across each insulating joint to protect it from high voltage surges. Surge diverters shall be suitable for installation in classified areas.

- 7.8.3. The total system including cables, cable termination, anodes/ surge diverters, polarization cell shall be suitable for the anticipated fault current at the location of installation.
- 7.8.4. The surge diverter and polarization cell system shall be suitable for the design life of permanent CP system. The grounding system shall have minimum resistance to earth to restrict the pipeline voltage as per NACE/VDE criteria but shall not exceed 5 Ohms.
- 7.8.5. The anodes shall be pre packed with special backfill adequately so that the performance of the anode is not affected by the carbonates, bicarbonates, nitrates, etc., present in the soil. In any case, the thickness of back fill shall not be less than 50mm on all the sides of the anode.
- 7.9. Motor operated valves where located on the Cathodically protected portion or the pipeline shall be grounded by a Zinc anode of 20 kg. Net Magnesium anodes grounding, if any, provided during temporary CP system shall be disconnected. The MOV power supply cable Armour shall be insulated (by cutting and taping with insulation tape) at MOV end to avoid Armour carrying CP current.
- 7.10. The above ground cathodically unprotected pipeline at terminals, intermediate SV stations, pigging stations etc. shall be earthed with GI earth electrodes. The resistance to earth of grounding shall be limited to 5 Ohms (Max.).

#### 7.11. POLARISATION COUPONS

Where specified in the project specification/data sheet steel coupons of pipeline material shall be provided along the pipeline to monitor the adequacy of the CP system to polarize/ protect coating holidays. Coupon shall be installed at CP station drainage points, predicted cathodic protection mid points along the pipeline, at locations where the pipeline is bonded to foreign pipeline/ structures, interference prone areas, marshy areas and at other locations as specified in the project specification/ data sheet, along the pipe line.



Coupons shall be installed at bottom 1/3" portion of the pipeline and 250 mm away from the pipe surface.

The coupons shall be constructed from the pipeline material and shall have one side uncoated surface of 100 mm x 100 mm exposed to soil. Two cables one for connection to pipeline for protection and other for potential measurement shall be provided for each coupon. The protection cable shall be connected through a magnetic reed switch inside the test station to enable measurement of coupon 'OFF' potential.

A permanent reference electrode shall be installed adjacent to the coupon in a manner so as to measure the representative potential of the coupon.

Magnets for operation of reed switch shall be provided as specified in the project specification/data sheet.



	<b>MRPL Marketing Terminal Project at Devangonhi, Bangalore</b> <b>Marketing Infrastructure Projects, MRPL</b>				
	Part - E	<b>STANDARD SPECIFICATION FOR IMPRESSED CURRENT CATHODOIC PROTECTION SYSTEM FOR PIPELINES</b>	Tender No.:		3200000495
	Section – E-1		Doc. No. :		20005-GEN-E-SPE-5020
	Subsection –E-1.13		Rev :		0

## 7.12. CP AT CASED CROSSING



- 7.12.1. At cased crossings where casing will have coating on its external surface, it shall be protected by sacrificial anode installations provided at both ends of casing. The anode installation shall be sized based on the permanent CP design parameters and design life of permanent CP system.
- 7.12.2. The carrier pipe inside the externally coated casing shall be protected by Zinc ribbon anodes piggy backed longitudinally on the carrier pipe between 4 and 8 O'clock position. Anode shall be tied with carrier pipe using Nylon rope at close intervals and weld connected at the ends. The quantity/ no. of ribbon anodes shall be based on the permanent CP design parameters for marshy area and design life of permanent CP system.

## 7.13. REFERENCE CELL ACCESS POINTS

Reference cell access points shall be provided near insulating joint locations and at SV stations, where the ground is paved, for measurement of pipe to soil potentials. A perforated PVC pipe filled with native soil and buried at the location shall be provided for the purpose. The length of the PVC pipe shall be adequate to reach the native soil below the paving.

## 7.14. CABLES

- 7.14.1. Cables shall be with annealed high conductivity stranded copper conductor, PVC insulated, 650/1100V grade, armoured, PVC sheathed conforming to IS 1554 part-I, except for the cables for anode tail, reference cells and pipeline for potential measurements. The size of the copper conductor shall be minimum 35 sq. mm. for anode and cathode cables, 6 sq.mm. For current measurement, 10 sq.mm. For anode tail cables and polarization coupon protection cables. The size of cable for bonding, polarization cell, grounding anodes and surge diverter connections shall be suitable for the maximum fault current subject to minimum 25 sq. mm.
- 7.14.2. The anode tail cables shall be PE insulated, 650V grade, unarmored, PVC sheathed and length shall be sufficient for termination on anode lead junction box without any joint in between.
- 7.14.3. The cables for reference cells, coupon and pipeline potential measurements shall be of 4 sq.mm. Copper conductor, PVC insulated, Aluminum backed by Mylar/ polyester tape shielded, PVC sheathed, armoured, PVC over all sheathed type.
- 7.14.4. The CPTR unit incomer cable shall be minimum 4 sq.mm. Copper conductor, 650/1100 V grade, PVC insulated, armoured, PVC sheathed. The cable shall be of 3 core type for single phase CPTR units and of 4 core type for 3 phase CPTR units.
- 7.14.5. The cables for connecting various transducers from CPTR unit/CPPSM to telemetry interface junction box shall be twisted pair with individual pair shielded and overall shielded with aluminum backed by Mylar/ polyester tape, PVC sheathed, armoured, PVC over all sheathed type.

	<b>MRPL Marketing Terminal Project at Devangonhi, Bangalore</b> <b>Marketing Infrastructure Projects, MRPL</b>				
	Part - E	<b>STANDARD SPECIFICATION FOR IMPRESSED CURRENT CATHODOIC PROTECTION SYSTEM FOR PIPELINES</b>	Tender No.:		3200000495
	Section – E-1		Doc. No. :		20005-GEN-E-SPE-5020
	Subsection –E-1.13		Rev :		0

## 8. INSTALLATION

### 8.1. CABLE LAYING

- i) Cables shall be laid in accordance with layout drawings to be prepared by the contractor. No straight through joint shall be permitted. Cable route shall be carefully measured and cables cut to required length. Minimum half meter cable slack shall be provided near anodes, anode junction box, and pipeline and test stations to account for any settling.
- ii) All cables inside station/plant area shall be laid at a depth of 0.75 meter. Cables outside station/ plant area shall be laid at a depth of minimum 1.5 meters. Cables shall be laid in sand under brick cover and back filled with normal soil. For cables laid outside the station /plant area, polyethylene warning mats shall be placed at a depth of 0.9 meter from the finished grade, to mark the route.
- iii) In case of above ground cables, all unarmored CP cables shall be laid in GI conduits of sufficiently large size, up to accessible height for protecting against the mechanical damage.
- iv) All underground unarmored cables including anode tail cables shall run through PE sleeves. Distant measurement cables and permanent reference cell cables routed along the pipeline shall be carried at the top of the carrier pipe by securely strapping it at intervals with adhesive tape or equivalent as required.
- v) PVC pipes of proper size shall be provided for all underground cables for road crossings.
- vi) Cables shall neatly arranged in trenches in such a manner that crisscrossing is avoided and final take-off to equipment is facilitated.
- vii) The cables for reference cells and pipeline potential measurement shall be routed in a separate trench other than the trench provided for the rest of the CP system cables, AC cables for CPTR Units etc.
- viii) The Armour of the cables from CP station to test station (potential measurement, reference cell & drainage cables etc.), CP station to ground bed (anode cable) and test station to pipeline shall be earthed only at CP station end and test station end respectively of the cables. The cable Armour shall be insulated (by taping with insulation tape) to avoid Armour carrying CP current.



### 8.2. PERMANENT REFERENCE CELLS

The permanent reference cells shall be installed in natural soil conditions as per the recommendations of the cell manufacturer. Installations in highly acidic/ alkaline soil and soil contaminated by hydrocarbons shall be avoided.

### 8.3. CABLE TO PIPE CONNECTIONS

All cable connections of other than cathode drainage cables to the new pipeline shall be made by an approved exothermic process or by pin brazing. The resistance of the cable to pipe at the pin brazing connection point shall not exceed 0.1 Ohm.

The cathode drainage cable shall be connected to a bolt welded to a metal plate, which is weld

	<b>MRPL Marketing Terminal Project at Devangonhi, Bangalore</b>				
	<b>Marketing Infrastructure Projects, MRPL</b>				
	<b>Part - E</b>	<b>STANDARD SPECIFICATION FOR IMPRESSED CURRENT CATHODIC PROTECTION SYSTEM FOR PIPELINES</b>	Tender No.:		3200000495
	<b>Section – E-1</b>		Doc. No. :		20005-GEN-E-SPE-5020
<b>Subsection –E-1.13</b>	Rev :		0		

connected to the pipeline. The material of the plate shall be same as that of the material of the pipeline.

Pipe coating shall be repaired after connection of cable to pipeline. At cathode drainage point the cable joint including the bolt, metal plate and the exposed portion of the pipeline shall be covered by the coating repair material against ingress of water/moisture. The coating repair material shall be compatible with the original coating and shall prevent ingress of water along the cable surface and at the interface of coating repair with the original pipe coating.

#### 8.4. GROUND BED FENCING

Where specified in project specifications/data sheet chain link fencing shall be provided around the location of each ground bed/anode Lead junction box.

### 9. FIELD TESTING AND COMMISSIONING

#### 9.1. SYSTEM TESTING AT SITE

Field tests as per the reviewed field testing and commissioning procedures prepared by the Contractor shall be carried out on the equipment/ systems before these are put into service. Acceptance of the complete installation shall be contingent upon inspection and test results. Field testing shall include but not be limited to the following:



- i) Contractor shall carry out pre-commissioning operations after completion of installation of the system including all pre-commissioning checks, setting of all equipment, control and protective devices. All site tests, reliability and performance tests shall be carried out by Contractor.
- ii) Before the electrical facilities are put into operation, necessary tests shall be carried out to establish that all equipment and devices have been correctly installed, connected and are in good working condition as required for the intended operation. Owner/Owners representative may witness all tests. At least one week's intimation notice shall be given before commencing the tests.
- iii) All tools, equipment and instruments required for testing shall be provided by Contractor.
- iv) Generally, the following minimum tests must be carried out and results shall be recorded:

Visual Inspection	Comparison with drawings, specifications, detailed physical inspection and, if necessary, by taking apart the component parts.
-------------------	--



Testing	Simulation tests of equipment to determine its operational fitness.
---------	---

##### a) Cables

- Cable No.
- Voltage grade.
- Conductor cross section
- Continuity check

	<b>MRPL Marketing Terminal Project at Devangonhi, Bangalore</b> <b>Marketing Infrastructure Projects, MRPL</b>				
	Part - E	<b>STANDARD SPECIFICATION FOR IMPRESSED CURRENT CATHODOIC PROTECTION SYSTEM FOR PIPELINES</b>	Tender No.:		3200000495
	Section – E-1		Doc. No. :		20005-GEN-E-SPE-5020
	Subsection –E-1.13		Rev :		0

- Voltage test.
  - Insulation resistance values between each core & earth, between cores (between core and earth for single core cable). All cables shall be tested by 500 V megger.
- b) Reference Cell**
- Location
  - Type of cell
  - Potential reading
  - Installed on top/ bottom level of pipeline
- c) Insulating Joint**
- Location
  - Pipe to soil potential of both protected and non-protected sides of the insulating joint before and after energization of CP system
- d) Surge Diverter**
- Location/ Identification Number
  - Rating
  - Type
  - Check for healthiness.
- e) Polarization Cell**
- Location/ Identification Number
  - Rating
  - Check for wiring
  - Check standby current drain after CP system energization (Current drain with respect to voltage across the cell shall be recorded)
  - Details of grounding provided for the polarization cell.
- f) Anode Ground Bed**
- Location/ Station
  - Check for actual layout and compliance with drawings
  - Resistance of each individual anode
  - Current dissipation by each individual anode
  - Total resistance of complete anode bed
  - Mutual interference

	<b>MRPL Marketing Terminal Project at Devangonhi, Bangalore</b> <b>Marketing Infrastructure Projects, MRPL</b>				
	Part - E	<b>STANDARD SPECIFICATION FOR IMPRESSED CURRENT CATHODOIC PROTECTION SYSTEM FOR PIPELINES</b>	Tender No.:		3200000495
	Section – E-1		Doc. No. :		20005-GEN-E-SPE-5020
	Subsection –E-1.13		Rev :		0



**g) Polarization Coupons**

- Location
- Exposed areal size of coupon
- Coupon to soil 'ON' and 'OFF' potentials
- Type of reference cell
- Magnetic reed switch rating
- Operation of magnetic reed switch with magnet

**9.2. CP COMMISSIONING PROCEDURE**

A model commissioning procedure for a three stations CP system of a pipeline is given below for general guidance. Contractor shall develop detailed commissioning procedure as per this guideline.

- i) On completion of installation of anode beds and other systems as envisaged in this specification, they shall be individually checked, tested and compared against the agreed specifications and procedure.
- ii) Electrical continuity of the entire pipeline shall be verified in conformity with design.
- iii) Input resistance of the pipeline at all the drainage points shall be checked and recorded.
- iv) All current measuring test stations shall be calibrated and recorded using portable battery, variable resistances, voltmeters, ammeters, etc. as required.
- v) Temporary protection facilities provided (if any) which do not form part of permanent CP shall be disconnected from the system & removed unless agreed otherwise.
- vi) Anodes provided for grounding at the MOVs on Cathodically protected portion of the pipeline shall be disconnected. Sacrificial anode where provided for the protection of the casing pipe at cased crossings shall be disconnected.
- vii) The pipeline shall be allowed to depolarize for at least 72 hours after switching 'OFF' the protection (if any) of all other pipelines in the common ROU.
- viii) Before the pipelines are put on charge by switching 'ON' any of the CP stations, natural pipeline to soil, casing pipe to soil and coupon to soil potential values at all the test stations of the system {coupon to soil potential at the locations of the coupon installations) shall be measured with respect to Copper/Copper Sulphate half-cell.
- ix) CP station no.1 shall be energized without put potential adjusted to achieve a maximum pipe to soil potential (PSP) as specified, at the test station nearest to the drainage point. Observations on either spread of protected portion of pipeline and coupons under this CP station shall be taken for PSP 'ON' and PSP 'OFF' values at each of the installed test stations (coupon to soil potential at the locations of the coupon installations). The typical switching cycle of current interrupter shall be 12 seconds 'ON' and 3 seconds 'OFF'. The pipeline current values across the cross section of the pipeline shall also be determined at

	<b>MRPL Marketing Terminal Project at Devangonhi, Bangalore</b> <b>Marketing Infrastructure Projects, MRPL</b>				
	Part - E	<b>STANDARD SPECIFICATION FOR IMPRESSED CURRENT CATHODOIC PROTECTION SYSTEM FOR PIPELINES</b>	Tender No.:		3200000495
	Section – E-1		Doc. No. :		20005-GEN-E-SPE-5020
	Subsection –E-1.13		Rev :		0

all the intended test stations influenced by this station.



- x) CP station no.1 shall now be switched 'OFF', CP station no. 3 shall be switched 'ON' and measurement procedure as detailed in clause ix) above shall be repeated.
- xi) Similarly CP station no. 1 and 3 shall now be switched 'OFF', CP station no.2 shall be switched 'ON' and measurement procedure as detailed in clause ix) above shall be repeated.
- xii) AU the CP stations of the system shall be switched 'OFF' and the pipelines shall be allowed to depolarize. All the three CP stations in the system shall then be simultaneously switched 'ON' and PSP values at the drainage points of pipeline shall be brought to a value of maximum PSP as specified and a complete set of observations shall be taken.

Another complete set of pipe to soil and coupon to soil observations shall be taken after lines have stayed on charge for 48 hours. If there are appreciable differences in these observations as compared to those of earlier set, a third set of observations shall be taken after 72 hours. Maximum drainage point protective potentials shall not be allowed to go beyond the maximum PSP values as specified, in any case.

Coupon to soil 'OFF' potential shall be measured at all locations of coupon installations by operation of magnetic reed switch in the test station. The PSP of the coupons shall be within the PSP range specified in clause 6 of this document.

The output of all CP stations shall then be so adjusted that the sites of occurrence of least negative protective potentials are not less negative than (-) 0.95V (OFF) and sites of occurrence of the most negative protective potential are not more negative than (-) 1.18V (OFF). A full set of pipe to soil, coupon to soil observations shall again be taken 72 hours after the adjustment of potentials and the protection system shall be left in this state of operation.

- xiii) Care shall be exercised to ensure that power supply remains uninterrupted during the period of commissioning. In case of an interruption, the test in progress shall be repeated after allowing time for polarization. More sets of observations shall be taken in any of the steps specified above, if advised by the Owner/Owner's representative.
- xiv) The Zinc anodes for grounding of MOVs at the locations of MOVs on Cathodically protected portion of the pipeline shall be reconnected to the MOVs.
- xv) At cased crossings where casing is protected, sacrificial anodes provided for the casing shall be connected to the casing pipe. The casing to soil potential and anode output current shall be measured and recorded. Where casing pipe protection is inadequate or the output current of the anode is more than the designed current, then additional anodes shall be provided as required.
- xvi) PSP values at each of the test stations of the existing pipelines shall be measured, plotted, where existing pipelines run in parallel to the new pipeline, mutual interference situations between the pipelines shall be identified and necessary mitigation measures shall be provided. Interference situations shall also be identified and mitigated by comparing



	<b>MRPL Marketing Terminal Project at Devangonhi, Bangalore</b> <b>Marketing Infrastructure Projects, MRPL</b>				
	Part - E	<b>STANDARD SPECIFICATION FOR IMPRESSED CURRENT CATHODIC PROTECTION SYSTEM FOR PIPELINES</b>	Tender No.:		3200000495
	Section – E-1		Doc. No. :		20005-GEN-E-SPE-5020
	Subsection –E-1.13		Rev :		0

different sets of readings taken at same test stations at different intervals of time under identical conditions where positive potential swing is 100 mV or more.

- xvii) Current readings at all the current measuring test stations shall be measured and recorded.
- xviii) Final records of testing and commissioning including graphical representation of final pipe to soil potential readings shall be compiled with interpretation in consultation with Owner/Owner's representative and submitted.
- xix) If any deficiencies are found in the system, the same shall be rectified by the contractor, at no extra cost or time schedule impact, to the complete satisfaction of Owner/ Owner's representative. Such deficiencies shall include mitigation of stray current electrolysis and interference problems that may be found existing in the course of testing and commissioning. A set of PSP observations shall also be taken during the peak of the first dry season after commissioning the system into regular operation. Any deficiency found in the protection of the pipeline shall be rectified by the contractor at his own cost.
- xx) If it is found during commissioning that the sites of occurrence of least negative or most negative protective potentials are less negative than (-) 0.95V (OFF) or more negative than (-) 1.18V (OFF) respectively even after 72 hours of operation, then the drainage point potentials shall be adjusted depending upon anode ground bed currents in consultation with Owner/Owner's representative. In any case, the protective 'OFF' potential values of pipeline and polarization coupons shall not exceed the PSP value range specified in clause 6 of this document, at any location on the pipeline.
- xxi) The reference cell shall be calibrated minimum once in 24 hours during the commissioning.
- xxii) The current dissipated by individual anodes shall be measured from the anode lead junction box and corrected for equal dissipation to the extent possible keeping the total ground bed current same.

## 10. INTERFERENCE MITIGATION

- 10.1. Investigations shall be made for stray current electrolysis of the pipeline, mutual interference between the pipeline and foreign pipelines/ structures, interference on foreign pipelines/structures due to the CP of the pipeline and ground bed, interference on metallic structures which lie in between pipeline and ground bed or near to ground bed, AC induction on pipeline due to overhead EHV/HV lines, interference due to high voltage DC lines, HVDC earthing system, electric traction etc.
- 10.2. Measurements including pipe/ structure to soil potentials and pipe/ structure currents etc. on the pipeline/ structure being CP protected and on foreign pipelines/ structures, and ground potential gradient etc. shall be made to investigate the current discharge and pickup locations. In case of fluctuating stray currents, investigations shall be made continuously over a period of time and if required simultaneously at different locations to find out the stray current source(s). Recorders shall preferably be used for long time measurements.
- 10.3. Wherever foreign pipelines which may or may not be protected by an independent CP system

	<b>MRPL Marketing Terminal Project at Devangonhi, Bangalore</b> <b>Marketing Infrastructure Projects, MRPL</b>				
	Part - E	<b>STANDARD SPECIFICATION FOR IMPRESSED CURRENT CATHODOIC PROTECTION SYSTEM FOR PIPELINES</b>	Tender No.:		3200000495
	Section – E-1		Doc. No. :		20005-GEN-E-SPE-5020
	Subsection –E-1.13		Rev :		0

run in parallel to the protected pipeline, either in the same trench or very near to the protected pipeline and are not bonded to it, investigations shall be performed for current discharge points on both the pipelines.



- 10.4. Mitigate measures shall be provided depending upon the type of stray current electrolysis/interference. These shall include installation of bond with variable resistor, diodes, installation of galvanic anodes for auxiliary drainage of current, adjustment/ relocation (i f possible) of offending interference source, provision of electrical shield etc. depending on the type of interference.
- 10.5. Bonding with foreign pipelines/ structures as a mitigation measure shall be provided where the owners of the foreign pipelines/ structures have no objection. Otherwise alternative mitigation measures shall be provided. Wherever bonding is provided for mitigation, the homing resistor shall be adjusted for optimum value for minimum/ no interference. Galvanic anodes installed as a mitigation measure shall be adequately sized for the life specified for permanent CP system.
- 10.6. Where overhead EHV/HV transmission lines/underground electric cables cross the pipeline or run in parallel with in or more than 25m from the pipeline, A.C. Voltage measurements shall also be made on the pipeline to find out continuous induction of voltage. In case of the induced voltage being beyond the safe limits, the pipeline shall be grounded in line with clause no.7.8 above.

#### 11. CLOSE INTERVAL POTENTIAL SURVEY

Where specified, contractor shall carry out a close interval 'ON'/'OFF' potential survey over the entire length of pipeline by computerized potential logging method and identify the under protected/ over protected area, any major coating damage on the pipeline, after the backfilling has been consolidated sufficiently and CP system has stabilized. Contractor shall provide required mitigation measures and rectify the under/ over protected zones, identify if any, the major pipeline coating defects, required to be repaired. During the survey the reference cell shall be calibrated minimum once in 24 hours. Detailed procedures for running this survey shall be submitted for review.

Additional tests for detailed identification of coating defects shall be conducted by the contractor, if specified in the project specification/ data sheets.



	<b>MRPL Marketing Terminal Project at Devangonhi, Bangalore</b> <b>Marketing Infrastructure Projects, MRPL</b>				
	Part – A	<b>PLANNING, SCHEDULING AND</b> <b>MONITORING PROCEDURE</b>	Tender No :	3200000495	
	Section – A-2		Document No:	20005-GEN-G- DOC-9105	
Subsection – -	Rev:		1		

<b>A-2</b>	<b>PLANNING, SCHEDULING AND</b> <b>MONITORING PROCEDURE</b>
------------	--

## MRPL Marketing Terminal Project at Devangonhi, Bangalore



**PROJECT :** Marketing Infrastructure Projects, MRPL

**OWNER :** MANGALORE REFINERY AND PETROCHEMICALS LTD

**PMC :** Nauvata Engineering Pvt. Ltd.



**JOB NO. :** JBG20005

1	10-May-2021	Issued for Bid	SP	ASN	ASN
0	09-Mar-21	Issued for Bid	SP	ASN	ASN
Rev. No.	Date	Description	Prepared By	Checked By	Approved By



	<b>MRPL Marketing Terminal Project at Devangonhi, Bangalore</b> <b>Marketing Infrastructure Projects, MRPL</b>				
	Part – A	<b>PLANNING, SCHEDULING AND MONITORING PROCEDURE</b>	Tender No :		3200000495
	Section – A-2		Document No:		20005-GEN-G- DOC-9105
Subsection – -	Rev:		1		

## TABLE OF CONTENTS



1.0	OVERVIEW .....	5
2.0	INTRODUCTION .....	5
3.0	DEFINITIONS AND ABBREVIATIONS .....	5
3.1	DEFINITIONS .....	5
3.2	ABBREVIATIONS .....	6
4.0	PROJECT CONTROL AND REPORTING .....	6
5.0	PROJECT PLANNING REQUIREMENTS .....	7
6.0	PROGRESS PLANNING, MEASURING AND REPORTING .....	7
6.1	PLANNING AND SCHEDULING .....	8
6.2	REVISION OF PLANNING AND SCHEDULING DOCUMENTS .....	10
6.3	GENERAL REQUIREMENTS .....	10
6.4	REVIEW TIME FOR PLANNING AND SCHEDULING DOCUMENTS .....	11
7.0	PROGRESS PLANNING .....	11
7.1	LEVEL I PROGRESS S-CURVES .....	11
7.2	DETAILED PROGRESS S-CURVES .....	11
7.3	PROGRESS MEASUREMENT SYSTEM .....	13
7.4	PROJECT PROGRESS WEIGHTAGE .....	13
7.5	PROGRESS MEASUREMENT SYSTEM .....	14
7.6	PROCUREMENT .....	16
7.7	CONSTRUCTION PROGRESS .....	17
7.8	COMMISSIONING PROGRESS MONITORING .....	17
8.0	PROGRESS MEASUREMENT .....	17
8.1	GENERAL .....	17

	<b>MRPL Marketing Terminal Project at Devangonhi, Bangalore</b> <b>Marketing Infrastructure Projects, MRPL</b>				
	Part – A	<b>PLANNING, SCHEDULING AND MONITORING PROCEDURE</b>	Tender No :		3200000495
	Section – A-2		Document No:		20005-GEN-G- DOC-9105
Subsection – -	Rev:		1		

8.2	ENGINEERING PROGRESS .....	18
8.3	CONSTRUCTION PROGRESS .....	18
9.0	PROGRESS REPORTING .....	19
9.1	MONTHLY PROGRESS REPORT .....	19
9.2	PROJECT CONTROLS .....	21
9.2.1.	Planning .....	21
9.2.2.	Quality .....	21
9.2.3.	Areas of Concern .....	21
9.2.4.	Progress Photographs and 3D CAD views .....	21
9.3	WEEKLY PROGRESS REPORT .....	21
9.4	DAILY CONSTRUCTION REPORTS .....	22
9.5	FINAL CLOSE-OUT REPORT .....	22
9.6	PROGRESS MEETINGS .....	22
9.7	WEEKLY PROGRESS MEETINGS .....	22
9.8	MONTHLY PROGRESS MEETINGS .....	22
9.9	SUBCONTRACTORS' AND VENDORS' PROGRESS MEETINGS .....	22
9.10	RECORDS .....	22
10.0	PROGRESS REVIEW CERTIFICATION .....	22
10.1	PROGRESS DOCUMENTATION .....	22
10.2	REVIEW AND CERTIFICATION .....	23
11.0	SCHEDULE CHANGE .....	23
11.1	PROCEDURE .....	23
11.2	CHANGE IDENTIFICATION .....	23
11.2.1.	Contractor Identified Changes .....	23
11.2.2.	PMC / MRPL Initiated Trend .....	23
11.2.3.	Cost of Trend Preparation .....	23
11.2.4.	Schedule Effects .....	24

	<b>MRPL Marketing Terminal Project at Devangonhi, Bangalore</b> <b>Marketing Infrastructure Projects, MRPL</b>				
	Part – A	<b>PLANNING, SCHEDULING AND MONITORING PROCEDURE</b>	Tender No :		3200000495
	Section – A-2		Document No:		20005-GEN-G- DOC-9105
Subsection – -	Rev:		1		

11.3	PMC / MRPL ASSESSMENT .....	24
11.4	IMPLEMENT CHANGE .....	24

	<b>MRPL Marketing Terminal Project at Devangonithi, Bangalore</b> <b>Marketing Infrastructure Projects, MRPL</b>				
	Part – A	<b>PLANNING, SCHEDULING AND</b>  <b>MONITORING PROCEDURE</b>	Tender No :		3200000495
	Section – A-2		Document No:		20005-GEN-G- DOC-9105
	Subsection – -		Rev:		1

## 1.0 OVERVIEW

- 1.1 Mangalore Refinery & Petrochemicals Ltd (MRPL) operates a 15 MMTPA crude processing refinery with secondary units and Petrochemical complex at Mangalore. MRPL proposes to put up a Petroleum storage & Marketing Terminal at Devangonithi, Bangalore to enhance and grow in its marketing business activities.
- 1.2 The proposed Terminal would cater to requirements of petroleum products for its own expanding Industrial & Retail business, primarily in the state of Karnataka & Kerala. The supplies of petroleum products to the retail outlets /customer / aviation stations would be met through road tankers. The entire Terminal operations would comply with the applicable statutory regulations and QC guidelines.

## 2.0 INTRODUCTION

This document 'Project Control Requirements', for the following Project control activities: Planning, Scheduling, Progress Measurement and Reporting for LSTK Tender A. The CONTRACTOR shall develop project specific procedures to cover all Project Planning, Scheduling and Reporting activities well before the start of the relevant activities. PMC / MRPL shall receive all the procedures for comments and approval. CONTRACTOR shall then implement the procedures during the execution of the Project.

## 3.0 DEFINITIONS AND ABBREVIATIONS

### 3.1 DEFINITIONS

For the purposes of this specification, the following definitions shall apply.

OWNER – MRPL (Mangalore Petrochemicals & Refinery Ltd.)

PMC – Project Management Consultant (Nauvata Engineering Pvt. Ltd.)

CONTRACTOR – a party contracted to MRPL to carry out work or services to the Project.

FIELD Services – is CONTRACTOR'S performance of construction and commissioning at the SITE

SITE – geographical area designated for MRPL Marketing Terminal at Devangonithi, Bengaluru

HOME OFFICE Services – is CONTRACTOR's performance of engineering, procurement and construction services



PROJECT – means the Setting up of MRPL Marketing Terminal at Devangonithi, Bengaluru

SHALL AND MUST – indicates a mandatory requirement

SUBCONTRACTOR – means any sub-supplier of any tier on whom the Vendor has directly or indirectly placed a suborder. If used in a Purchase Order the term sub-supplier shall have the same meaning as Subcontractor

VENDOR – means the firm, company or other corporate entity (including its successors and / or permitted assigns) contracted through a Purchase Order

CONTRACT – means the CONTRACT between the CONTRACTOR / VENDOR and MRPL for the supply of the equipment / Services

	<b>MRPL Marketing Terminal Project at Devangonhi, Bangalore</b> <b>Marketing Infrastructure Projects, MRPL</b>				
	Part – A	<b>PLANNING, SCHEDULING AND MONITORING PROCEDURE</b>	Tender No :		3200000495
	Section – A-2		Document No:		20005-GEN-G- DOC-9105
Subsection – -	Rev:		1		

TREND – is defined as a potential alteration in work scope or process which will result in a change

VARIATION – variation is defined as any and all changes in or relative to the services, and amendments to the Agreement

CONTRACT TREND NOTICE – is the formal documentation that records the trend basis, scope, cost and schedule

### 3.2 ABBREVIATIONS

MC - Mechanical Completion  
RFSU – Ready for Start Up  
WBS – Work Breakdown Structure  
FOB – Free On Board  
CPM – Critical Path Method  
ROS – Required On Site  
MS – Motor Spirit  
HSD – High Speed Diesel  
ATF – Aviation Turbine Fluid  
MRPL - Mangalore Petrochemicals & Refinery Ltd.

### 4.0 PROJECT CONTROL AND REPORTING

CONTRACTOR shall provide the project schedule, milestones and project schedule narrative in accordance with the Project Control requirements, and tender documentation.

CONTRACTOR shall note that the Schedule and the Milestones submitted by the CONTRACTOR shall form part of the CONTRACT.



CONTRACTOR shall provide Schedules, Histograms, Progress Measurement System, and Progress ‘S’ Curves, as covered in sections 5 and 6 as a part of bid document.

CONTRACTOR shall provide the following Project Control documents upon award of project:

- Progress Measurement System
- Schedule – Level 1 and 2
- Milestones – key milestones for Engineering, Procurement, Construction, Commissioning, Hydraulic Guarantee and Closeout
- Schedule Narrative
- Progress ‘S’ Curves
- Procurement Tracking Schedule
- Manpower Histogram for Home Office Services
- Manpower Histogram for Construction Works
- Construction Plant / Equipment Deployment Schedule
- CONTRACTOR shall provide a statement of compliance with PMC / MRPL’s Project Control requirements and associated procedures

Description of CONTRACTOR’S Project Control Organisation

- Contractor shall provide a description of the Project Control organisation, its main functions, and the responsibilities and duties of the principal assigned individuals, including their CV’s. This shall include the Planning, Scheduling, Progress Control, Cost Control and Reporting functions as a minimum. Description shall explain how the organisation will ensure the

	<b>MRPL Marketing Terminal Project at Devangonhi, Bangalore</b> <b>Marketing Infrastructure Projects, MRPL</b>				
	Part – A	<b>PLANNING, SCHEDULING AND</b>  <b>MONITORING PROCEDURE</b>	Tender No :		3200000495
	Section – A-2		Document No:		20005-GEN-G- DOC-9105
Subsection – -	Rev:		1		

integration of Project Control function between the Home Office, other WORK locations, the SITE, SUBCONTRACTORS and VENDORS.

Description of Contractor's Project Control procedures/ systems

- CONTRACTOR shall submit details of its proposed Planning, Scheduling and Progress Measurement and Progress Reporting procedure, along with the unpriced technical offer.

Description of CONTRACTOR'S Project Control computer software/ applications

- CONTRACTOR shall use PRIMAVERA (P6.0 or later) computer software / applications for Planning, Scheduling, Progress Control and Reporting.

Description of CONTRACTOR'S Document Control and Materials Management interfaces with Project Control systems

- CONTRACTOR shall provide a description of how CONTRACTOR'S Document Control and Materials Management functions interface with the planning and progress measurement and payment systems within the Work Breakdown Structure and Organisation Breakdown Structure. CONTRACTOR shall provide sample reports from the systems proposed.

## 5.0 PROJECT PLANNING REQUIREMENTS

The Scope of Project Planning, Scheduling and Monitoring Services to be performed by CONTRACTOR shall include, but not be limited to the functions as described under the following.



- Planning
- Scheduling
- Monitoring
- Updating
- Reporting

CONTRACTOR's Project Planning team shall be responsible for submitting CONTRACTOR's project Planning, scheduling and Monitoring procedures, establishing project measurement systems, and mobilising a suitably qualified and experienced project control team to execute the project Planning, Scheduling, Monitoring and reporting requirements. CONTRACTOR shall use computerised systems to the maximum extent possible for the Project Planning, Scheduling, Monitoring and Reporting Services. Such systems shall be capable of electronic interface between CONTRACTOR's Home Offices and SITE and PMC / MRPL offices. CONTRACTOR shall provide PMC / MRPL with access to Planning & Scheduling data as requested. CONTRACTOR shall also provide PMC / MRPL, as required, with updated Schedules, networks, planning and Change databases via electronic and hard copies throughout the duration of the Project. CONTRACTOR shall develop detailed procedures for each of the functions described in this section for review and approval by PMC / MRPL. Procedures shall be completed and submitted for PMC / MRPL approval within **Two (2) weeks** of Contract award.

## 6.0 PROGRESS PLANNING, MEASURING AND REPORTING

The purpose of this section is to define the PMC / MRPL's requirements for the CONTRACTOR'S method of planning and scheduling. It is provided to the CONTRACTOR as a guideline for the specification and definition of the PMC / MRPL's minimum requirements for the works. CONTRACTOR is to use this guideline to develop the procedure required for PMC / MRPL's approval.

- Planning and Scheduling
- Progress Planning
- Progress Measurement
- Progress Reporting

	<b>MRPL Marketing Terminal Project at Devangonhi, Bangalore</b> <b>Marketing Infrastructure Projects, MRPL</b>				
	Part – A	<b>PLANNING, SCHEDULING AND</b>  <b>MONITORING PROCEDURE</b>	Tender No :		3200000495
	Section – A-2		Document No:		20005-GEN-G- DOC-9105
Subsection – -	Rev:		1		

- Progress Review and Certification

## 6.1 PLANNING AND SCHEDULING

### 6.1.1. Planning Hierarchy

CONTRACTOR shall use, as a minimum, the following hierarchical basis for planning and scheduling. This shall apply to both Design office and Field planning efforts, and conform to the following structure.

- Level 1 - Project Management Schedule
- Level 2 - Master Schedule
- Level 3 - Detail Engineering, Procurement and Construction CPM Network
- Level 4 - Registers

### 6.1.2. Level I - Project Management Schedule

The Level I Project Management Schedule shall be in sufficient detail to demonstrate how the CONTRACTOR plans to execute the WORK within the Milestone dates. It shall be based on the CONTRACTOR'S approved WBS structure and shall identify the Major Project Milestones.

Additional activities, key dates and interfaces shall be shown where this aids the demonstration of critical or high-risk elements of the WORK.

The Level I Project Management Schedule shall include construction and commissioning activities in sufficient detail to demonstrate how CONTRACTOR expects construction and commissioning activities to be planned based on the release of 'Issued for Construction' engineering documents and FOB delivery of equipment and materials.

Typically, the Level I Project Management Schedule shall be a logical presentation on a single sheet, suitable for reduction to A3 or A4 format, containing 50 to 60 lines. It shall summarise for each Level I WBS element the main phases of the Level II WBS. The format of the Level I Project management schedule shall be agreed with PMC / MRPL.

The Level I Project Management Schedule shall be front lined with a status line representing the remaining duration of the activities in progress determined from the lower level schedules. The Level I shall be included in the monthly progress report.

Once established as a baseline, the Level I schedule shall not be changed without PMC / MRPL approval. Actual and forecast variances from the schedule shall be shown clearly in a format acceptable to PMC / MRPL.

### 6.1.3. Level 2 – Master Schedule



The SCHEDULE submitted along with the Tender, shall be updated to reflect the modifications agreed with PMC / MRPL prior to award of CONTRACT and the actual effective date for the Project. This will become the Master Schedule.

### 6.1.4. Level 3 – Detail Engineering, Procurement and Construction CPM Network

A Level III schedule in the form of detailed precedence CPM networks and based on the approved WBS shall be prepared by CONTRACTOR and submitted for PMC / MRPL review within **Four (4) weeks** of CONTRACT award. Once agreed with PMC / MRPL, this schedule shall be "baselined" and set as a target against which CONTRACTOR shall compare all subsequent reporting.

The Level 3 CPM Network shall be based on the Contract Master Schedule for the WORKS and shall be in greater detail to reflect the milestones sequence and inter-relationships between various



	<b>MRPL Marketing Terminal Project at Devangonhi, Bangalore</b> <b>Marketing Infrastructure Projects, MRPL</b>				
	Part – A	<b>PLANNING, SCHEDULING AND MONITORING PROCEDURE</b>	Tender No :		3200000495
	Section – A-2		Document No:		20005-GEN-G- DOC-9105
Subsection – -	Rev:		1		

activities and sub-activities related to each Area / Phase / Discipline of work. The Network / Bar chart shall ensure integration of engineering, procurement & delivery, subcontracting, construction, pre-commissioning, commissioning, closeout and all other activities required for completion of the WORK in line with PMC / MRPL priorities and agreed sequence. Responsibilities and resources required to carry out the execution of each activity shall be identified. The Network / Bar Chart shall be construction driven and shall include all sub-activities up to the lowest level, under each category/group of activities by Area / Phase / Discipline etc. as per the scope of work. The Network shall be coded to highlight all external interface requirements outside the control of the CONTRACTOR. These interface activities shall be updated along with each schedule update cycle and any changes with regard to their availability shall be communicated to PMC / MRPL along with their impact if any.

The integrated time scaled logic network which will be prepared by using 'PRIMAVERA' software shall be self-explanatory and the activity coding structure shall provide reference to Area / Phase / Discipline / Subcontract etc. as per the approved Work Breakdown Structure (WBS) to enable effective organizing and report sorting. Activity coding structure shall also enable filtering of all activities / sub activities related to the following:

- Interface activities
- Engineering, Procurement and Construction activities related to long lead items (LLIs)
- High Risk / Critical Activities (< 2 weeks float)
- Milestones

CONTRACTOR shall continue to develop and maintain the Detailed Schedule throughout the engineering, procurement and construction period, taking into consideration latest philosophies, strategies, design, material, access and manpower requirements. The Detailed Schedule shall also be used by CONTRACTOR as the prime vehicle for constructability planning exercises such as heavy lift crane movements scheduling etc.

The extent of detailing of the Schedule shall meet PMC / MRPL requirements such that the effect of any significant delay or change in the course of the execution of the WORKS can be clearly explained, evaluated and controlled. CONTRACTOR will, on request by PMC / MRPL, expand the Schedule logic in key areas, and provide copies of logic diagrams and Schedule reports for all or any part of the Detailed Schedule.



#### 6.1.5. Level 4 - Registers

The control tools included in this level are primarily documents used to track and measure progress of the work at an identifiable deliverable level including, but not limited to, the following:

- Engineering Deliverables Status Reporting
- Procurement Status Reporting
- Subcontracts Schedule
- Three Week Look ahead Schedule
- Systems Completion Schedule

#### 6.1.6. Three Week Look ahead

During the Construction phase, Three-week Look-Ahead Schedules shall be prepared for all disciplines, to indicate specific items of work to be accomplished over the forthcoming three weeks and activity completed in the previous week. This Schedule shall form part of CONTRACTOR's Weekly Progress Report and updated weekly. This Schedule shall clearly show any internal or external information flow or decision constraints that are hindering progress.

	<b>MRPL Marketing Terminal Project at Devangonhi, Bangalore</b> <b>Marketing Infrastructure Projects, MRPL</b>				
	Part – A	<b>PLANNING, SCHEDULING AND MONITORING PROCEDURE</b>	Tender No :		3200000495
	Section – A-2		Document No:		20005-GEN-G- DOC-9105
Subsection – -	Rev:		1		

#### 6.1.7. Systems Completion Schedule

CONTRACTOR shall prepare a SYSTEMS Completion Schedule for review and approval by PMC / MRPL. The SYSTEMS Completion Schedule will be used to establish MECHANICAL COMPLETION (MC), READY FOR COMMISSIONING (RFC) and READY FOR START-UP (RFSU) dates for each SYSTEM and will supplement the Detailed Schedule as the working tool. The SYSTEMS Completion Schedule will be put in place prior to the transition to SYSTEMS Completion in the FIELD and must support the requirements of the agreed START-UP Schedule.

#### 6.1.8. Minimum Requirements for Scheduling

LSTK Contractor shall follow below mentioned minimum requirements while preparing the Detail Schedule.

1. Schedule shall be developed using Precedence Diagram Method.
2. Schedule shall be built using logical sequencing of activities.
3. Duration of any activity shall not exceed more than 40 days.
4. Lag / Lead shall not exceed more than 20 days.
5. Start to Finish (SF) linkage shall not be used while developing the schedule.
6. Hard Constraints shall not be used while developing the schedule. Only Soft Constraint shall be used.
7. All activities shall have at least one predecessor and one successor activity as a minimum except for Project Start and Project Finish Activities.
8. Schedule shall be resource loaded.
9. All Long lead items shall be identified and scheduled so that receipt of such long lead items at site is on time so as not to affect downstream activities.

#### 6.1.9. Critical Path



LSTK Contractor shall identify all the critical paths on the project while developing the Baseline Schedule. All activities with float < 2 weeks shall be considered as Critical activities. Any change in the critical paths along with its impact on the overall Project completion shall be highlighted to PMC / MRPL by Contractor immediately during the project execution. A narrative shall be furnished indicating the reasons for variation of critical path, the critical activities, the reasons thereof and remedial / additional measures proposed to be taken to bring back the project on to the original critical path and any assistance needed by the PMC / MRPL. Any hindrances which may affect the work / Critical path may be notified to PMC / MRPL in advance. The status of critical activities which may affect the critical path needs to be identified at least a week in advance and initiate corrective / preventive actions under intimation to the PMC / MRPL. Any corrective actions by PMC / MRPL also needs to be anticipated and informed at least a week in advance to provide sufficient time for corrective / preventive actions.

### 6.2 REVISION OF PLANNING AND SCHEDULING DOCUMENTS

CONTRACTOR shall use appropriate software and computerised systems, which will be flexible enough to accommodate any changes in the scope of WORK, basis of scheduling and reporting etc. However, all such changes will be reflected in the Planning and Scheduling documents only after PMC / MRPL approval.

CONTRACTOR shall note that the submission of revised programmes by the CONTRACTOR and subsequent approval of the same by PMC / MRPL during the period of PROJECT implementation shall not relieve the CONTRACTOR from his Contractual obligations. All such revisions shall only be treated as a part of the control mechanism for effective monitoring so as to arrest/minimize progress slippages during the period of implementation.

### 6.3 GENERAL REQUIREMENTS

	<b>MRPL Marketing Terminal Project at Devangonhi, Bangalore</b> <b>Marketing Infrastructure Projects, MRPL</b>				
	Part – A	<b>PLANNING, SCHEDULING AND</b>  <b>MONITORING PROCEDURE</b>	Tender No :		320000495
	Section – A-2		Document No:		20005-GEN-G- DOC-9105
Subsection – -	Rev:		1		

CONTRACTOR shall submit to PMC / MRPL updated Level 1 Project Management Schedule, Level 3 Detail Engineering, Procurement and Construction CPM Network and all other Working Schedules in requisite copies along with soft copies of the same at the time of initial submission as well as during periodic updation. All soft copies shall be in their native formats (not in pdf. Formats). Contractor shall also in addition refer to Documentation requirements stated elsewhere in the tender documents.

#### 6.4 REVIEW TIME FOR PLANNING AND SCHEDULING DOCUMENTS

PMC / MRPL shall require ten (10) working days for review of all Planning and Scheduling related documents. CONTRACTOR shall accommodate for this duration in the Level III CPM Schedule.

#### 7.0 PROGRESS PLANNING

Throughout the duration of the WORK, CONTRACTOR shall establish and report against a series of progress control curves and equivalent manpower histograms. The baseline curves shall show the planned monthly progress, and be developed using planned dates from the Level III schedule. During the execution of the WORK, the actual weekly and monthly progress shall be compared with the planned.

The CONTRACTOR shall develop a method for the measurement of physical progress to report actual progress against a series of progress control curves. CONTRACTOR is required to develop the detailed progress measurement system based on this procedure. Once approved, the progress control curves and associated weightage will remain fixed unless changes are approved by OWNER.

CONTRACTOR shall provide PMC / MRPL with unlimited access to CONTRACTOR's progress measurement data for the purposes of verification of progress through all phases of the WORK as required in the Progress Review and Certification Procedure.

#### 7.1 LEVEL I PROGRESS S-CURVES

##### 7.1.1. Overall Progress S-Curves

Overall progress curves shall be developed to monitor progress of the WORKS. The curves shall be based on the approved SCHEDULE and weighted in accordance with PMC / MRPL's progress weightage, refer Section 6. Progress figures shall be shown in graphical and tabular format and compare actual progress with the planned progress baselines. Contract progress curves shall be prepared for the following:



- Overall Progress
- Engineering Progress
- Procurement and Subcontracting Progress
- Overall Construction Progress
- Overall Commissioning progress

##### 7.1.2. Manpower Histograms

Manpower histograms shall be developed showing the planned manpower for the entire duration of the WORKS, separately for Engineering, Procurement & Subcontracting, Construction, Pre Commissioning & Commissioning and overall. Actual mobilised manpower shall be indicated to show comparison with plan. In the case of major rescheduling of the WORKS, the revised manpower loading shall be based on any agreed changes to the Master Schedule.

#### 7.2 DETAILED PROGRESS S-CURVES

##### 7.2.1. Progress Curves

	<b>MRPL Marketing Terminal Project at Devangonhi, Bangalore</b> <b>Marketing Infrastructure Projects, MRPL</b>				
	Part – A	<b>PLANNING, SCHEDULING AND MONITORING PROCEDURE</b>	Tender No :		3200000495
	Section – A-2		Document No:		20005-GEN-G- DOC-9105
Subsection – -	Rev:		1		

Based on the Summary Schedule, CONTRACTOR shall provide Progress Curves showing planned, actual and forecast data for each of the following.

Engineering progress

- Major Disciplines

Procurement, Subcontracting and Expediting Services

- Equipments / Items / Materials
- Bulk Materials

Construction progress curves

- Major Discipline
- Subcontract
- Area / Unit

Completion progress curves

- Pre Commissioning
- Commissioning

#### 7.2.2. Manpower Histograms

For each of the Detailed Progress S-Curves CONTRACTOR shall prepare compatible manpower histograms. For Engineering, histograms shall be prepared for each discipline; for Construction, histograms shall be prepared showing trades within a subcontract. During the execution of the WORK, the actual equivalent staffing shall be compared to the planned and a forecast shall be produced to support any progress curves as necessary. Equivalent staffing calculations shall be based on the standard working hours/week at the work location.

#### 7.2.3. Engineering Manpower Schedule



CONTRACTOR shall submit in the Monthly Report the “Manpower Schedule for Engineering Services” along with “Manpower Histogram for Engineering Services” in a tabular form.

CONTRACTOR shall note the following requirements while preparing the details in the above formats:

- Designations indicated in the enclosed formats are only indicative and may be changed as required, to suit to CONTRACTOR’s own
- PMC / MRPL Organization Structure. However, CONTRACTOR shall not change the grouping of personnel identified in the above formats.
- Designations indicated in the proposed Organization Chart, Manpower Schedule and all other related documents shall be identical.
- “Manpower Schedule for Engineering Services” shall reflect only the manpower required for HOME OFFICE Services, including Subcontractors’ manpower for specialty services required if any, for the entire duration of contract.

#### 7.2.4. Construction Manpower Schedule

CONTRACTOR shall submit in the Monthly Report the “Construction Manpower Schedule” along with “Manpower Histogram for Construction Works” in a tabular form as per the formats enclosed in Attachments 4 & 5.

	<b>MRPL Marketing Terminal Project at Devangonhi, Bangalore</b> <b>Marketing Infrastructure Projects, MRPL</b>				
	Part – A	<b>PLANNING, SCHEDULING AND</b>  <b>MONITORING PROCEDURE</b>	Tender No :		3200000495
	Section – A-2		Document No:		20005-GEN-G- DOC-9105
	Subsection – -		Rev:		1

Construction works (Field activities) also include activities related to workshop, fabrication yard and other activities.

CONTRACTOR shall note the following requirements while preparing the details in the above formats.

- Designations indicated in the enclosed formats are only indicative and may be changed as required, to suit to CONTRACTOR's own Organization Structure. However, CONTRACTOR shall not change the grouping of personnel identified in the above formats.
- Designations and number of persons indicated in the Proposed Organization Chart, Manpower Schedule and all other related documents shall be identical.
- "Direct Manpower (Field Supervision staff)" shall include all Engineers (Supervisory personnel), who are directly involved in the supervision of construction and pre-commissioning works as well as yard activities etc. (viz. Construction Manager, Engineers, Superintendents and other Engineers connected with Construction and Pre-commissioning, Survey, HSE, QA/QC etc.) Manpower details shall be furnished separately against each discipline (viz. Civil, Piping, Mechanical, Electrical, Instrumentation etc.)
- "Direct Manpower (Non-Supervisory staff)" shall include all Non-Supervisory personnel below the level of Foremen (including Foremen) who are directly involved in the field activities (viz. Foremen and below including skilled / semi-skilled / unskilled workmen, Equipment Operators, Heavy Equipment Drivers, etc.).
- Indirect Manpower (Field Management) shall include all personnel who are essentially office based and are not directly involved in the construction supervision activities (viz. Project Manager, Project Control Engineers, Procurement / Material Control/ Expediting Engineers, Contract / Subcontract Administrators / Engineers, Field Engineering Personnel, Warehousing personnel etc.)
- Subcontractor manpower shall be indicated separately against each of the proposed subcontracts (if any)
- Other Office Staff including Administration / Personnel, Finance / Accounts and Camp staff (Viz. catering, maintenance, janitorial services, etc.) shall not be included in the Manpower Schedule.
- Construction Manpower Schedule shall reflect only the Manpower required for construction services, including subcontractors' manpower (separately against each subcontract) and Vendor Engineers if any, for the entire duration of project.

### 7.3 PROGRESS MEASUREMENT SYSTEM



Progress S curves identified in the sections above shall be updated with progress and issued within the Monthly Reports.

CONTRACTOR is to submit the proposed progress measurement system that will be used throughout the duration of the project.

CONTRACTOR is to establish suitable computer software to track and update the status of each deliverable, with the ability to roll up progress to the respective reporting levels. CONTRACTOR's progress measurement system shall satisfy at the least the criteria contained within 6.4 and 6.5.

### 7.4 PROJECT PROGRESS WEIGHTAGE

The overall weightage established will remain fixed unless there are changes in total work scope of a large magnitude, or the basis originally assumed is agreed to have changed significantly. Any change will require PMC / MRPL's approval prior to implementation.

	<b>MRPL Marketing Terminal Project at Devangonhi, Bangalore</b> <b>Marketing Infrastructure Projects, MRPL</b>				
	Part – A	<b>PLANNING, SCHEDULING AND</b>  <b>MONITORING PROCEDURE</b>	Tender No :		3200000495
	Section – A-2		Document No:		20005-GEN-G- DOC-9105
Subsection – -	Rev:		1		

Overall Progress Weightage Physical progress shall be assessed for the total scope of the WORKS, i.e. Engineering, Procurement & Subcontracting, Construction, Pre commissioning & Commissioning, As-built and Project Closure.

Weightage for Engineering, Procurement & Subcontracting, Construction, Pre commissioning & Commissioning, As-built and Project Closure are to be tabulated as given below. Weightage shall be evaluated based on either estimated man-hours or costs by CONTRACTOR and shall be approved by OWNER before implementation.

CATEGORY	WEIGHTAGE (%)
Engineering	
Procurement, Subcontracting & Expediting	
Construction	
Pre Commissioning and Commissioning	
As built	
Project Closeout	
Overall	

## 7.5 PROGRESS MEASUREMENT SYSTEM

CONTRACTOR's Progress Measurement System shall establish suitable tools to track and measure the progress of the work.

### 7.5.1. Engineering Progress

#### Engineering Deliverable Register

A database shall be prepared listing all engineering deliverables to be developed disciplinewise. Based on the detailed schedule, requirement dates shall be incorporated for each deliverable.

The register shall include all procedures, studies, reports, data sheets, specifications, drawings, material requisitions or other documents to be produced during Engineering phase.

CONTRACTOR's system shall be capable of producing Summary and Discipline level reports to meet PMC / MRPL's requirements and made available to PMC / MRPL as required.

This database shall be capable of generating reports to meet PMC / MRPL requirements such as,

- Summary table by discipline and by type of deliverable planned together with actual achievements for the period and cumulative.
- Deliverables already completed and issued.
- Deliverables planned for completion but not completed.
- Deliverables due for issue in next period.



Guidelines for the format of these reports are provided in Attachments 7 and 8.

#### Progress Evaluation

Weightage shall be established for each deliverable based on the estimated manhours. CONTRACTOR shall follow the percentage stage progress as below for various stages for each types of documents (Specifications, Datasheets, Reports, MTOs, etc.) and drawings for PMC / MRPL review and approval.

#### a) Approval Category documents

Activity	Progress (%)	
	Incremental	Cumulative
Start	10%	10%

	<b>MRPL Marketing Terminal Project at Devangonhi, Bangalore</b> <b>Marketing Infrastructure Projects, MRPL</b>				
	Part – A	<b>PLANNING, SCHEDULING AND MONITORING PROCEDURE</b>	Tender No :		3200000495
	Section – A-2		Document No:		20005-GEN-G- DOC-9105
Subsection – -	Rev:		1		

Activity	Progress (%)	
	Incremental	Cumulative
Draft Complete	10%	20%
Issue for IDC	25%	45%
IDC Closure	0%	45%
Issue for PMC / MRPL review	15%	60%
Receive PMC / MRPL comments	0%	60%
Issue for PMC / MRPL Approval	30%	90%
Receive PMC / MRPL Approval	0%	90%
Issue as IFC / AFC	10%	100%

## b) Review Category documents

Activity	Progress (%)	
	Incremental	Cumulative
Start	10%	10%
Draft Complete	10%	20%
Issue for IDC	25%	45%
IDC Closure	0%	45%
Issue for PMC / MRPL review	15%	60%
Receive PMC / MRPL comments	0%	60%
Issue for Information	40%	100%

## c) Documents for Safety Studies (HAZOP, etc.)



Activity	Progress (%)	
	Incremental	Cumulative
Start	10%	10%
Draft Complete	10%	20%
Issue for IDC	25%	45%
IDC Closure	0%	45%
Issue for PMC / MRPL review	15%	60%
Receive PMC / MRPL comments	0%	60%
Issue for HAZOP	10%	70%
Receive HAZOP Recommendation	0%	70%
Issue for PMC / MRPL Approval	20%	90%
Receive PMC / MRPL Approval	0%	90%
Issue as IFC / AFC	10%	100%

## d) Information Category documents

Activity	Progress (%)	
	Incremental	Cumulative
Start	10%	10%
Draft Complete	10%	20%
Issue for IDC	25%	45%
IDC Closure	0%	45%
Issue for Information	55%	100%

## e) MTOs

Activity	Progress (%)	
	Incremental	Cumulative

	<b>MRPL Marketing Terminal Project at Devangonhi, Bangalore</b> <b>Marketing Infrastructure Projects, MRPL</b>				
	Part – A	<b>PLANNING, SCHEDULING AND MONITORING PROCEDURE</b>	Tender No :		3200000495
	Section – A-2		Document No:		20005-GEN-G- DOC-9105
	Subsection – -		Rev:		1
1 <sup>st</sup> MTO Submission		50%	50%		
2 <sup>nd</sup> MTO Submission		30%	80%		
3 <sup>rd</sup> MTO Submission		20%	100%		

## 7.6 PROCUREMENT

CONTRACTOR shall report progress for raising requisitions and awarding subcontracts with progress, equipment fabrication and supply of bulks to receipt of items at site.

### 7.6.1. Procurement Register

The Procurement Register shall track all Goods / Equipments / Materials / Items / Bulks for the Works, from RFQ stage through Purchase Order issue, Material Shipment and Receipt at jobsite. For each requisition the Required On Site (ROS) date shall also be established based on the Detailed Schedule and the requirement dates incorporated for each stage of the procurement chain up to placement of order and receipt of vendor data. Actual dates shall be shown for each stage to show progress accomplished, and wherever Schedule dates cannot be met, a forecast shall be indicated.

Where a forecast date exceeds the ROS date, a recommended recovery plan shall be indicated by CONTRACTOR. Such system shall also be capable of producing summary reports to meet PMC / MRPL's requirements. It shall also provide the means to review the status and evaluate potential project schedule delays on account of material delivery.

Guidelines for the format of these reports are provided in Attachments 9 and 10.

### 7.6.2. Procurement Progress Evaluation

Procurement Services progress will be evaluated at the Control Level by weighting each Material Requisition (MR) by the estimated cost of Equipment / Item / Material and monitoring progress from a series of progress milestones from RFQ through to close-out.

Distribution of percentage at various stages of procurement for each individual Material Requisition will be kept same, for calculating procurement progress. The number of Requisitions / Purchase Orders shall be estimated initially and will be updated as the Procurement Plan is finalized.



A fixed milestone and percent complete pattern shall be determined for each Material Requisition / Purchase Order, starting with Prequalification stage and finishing with Purchase Order close-out as detailed in the following table. Progress against each Material Requisition will be measured under various major stages.

Description	Equipments	Bulk Materials
Issue MR / RFQ to Vendors	20%	20%
Issue Final TBE	30%	30%
Place PO on Vendor	40%	40%
Vendor Drawings Approval Completion	50%	-
FAT Successfully Conducted	85%	85%
Dispatch from Vendor's Premisis	90%	90%
Receipt of Material at Site	100%	100%

### Subcontracts Schedule

The Subcontract status report shall show for all subcontracts the required dates for the key stages of the subcontract chain and track progress from initial prequalification stage through award of



	<b>MRPL Marketing Terminal Project at Devangonhi, Bangalore</b> <b>Marketing Infrastructure Projects, MRPL</b>				
	Part – A	<b>PLANNING, SCHEDULING AND</b>  <b>MONITORING PROCEDURE</b>	Tender No :		3200000495
	Section – A-2		Document No:		20005-GEN-G- DOC-9105
Subsection – -	Rev:		1		

subcontract. The number and types of subcontract shall be determined as part of the Subcontracting Plan.

Guidelines for the format of these reports are provided in Attachment 11.

### Subcontract Progress Evaluation

CONTRACTOR shall distribute the total budgeted man-hours for subcontracting services and each contract shall be assigned a weighted value based on the complexities. Achieved progress shall be reported based on the progress milestone pattern and fixed percent completions for all milestones as detailed in the following table. Progress shall be evaluated by monitoring each SUBCONTRACT package according to milestones.

Issue RFQ to Subcontractors	35%
Bid Analysis and Clarifications	90%
Subcontract Award	100%

### 7.7 CONSTRUCTION PROGRESS

The Construction / Pre-Commissioning / Mechanical Completion / Commissioning Progress measurement basis shall be developed by CONTRACTOR and submitted for PMC / MRPL's approval.

A detailed Construction Progress Measurement System shall be developed by CONTRACTOR in such a way that physical progress can be reported both by area or discipline or by subcontract. CONTRACTOR shall prepare back-up documentation such as quantities / resources, etc to support the suggested weightage. In each area physical quantities of work involved shall be indicated. Additional guidelines are provided in Attachments 15 & 16 to this procedure.

Pre-Commissioning / Commissioning Progress Measurement shall be developed and weighted on a system basis, and provided for PMC / MRPL's review and approval.

### 7.8 COMMISSIONING PROGRESS MONITORING

At a mutually agreed stage of the construction Schedule, CONTRACTOR shall transition from Area / Unit erection to a Systems approach. Suitable tools to plan and control the transition shall be in place prior to the move to Systems. CONTRACTOR's field progress reporting system shall be capable of measuring and reporting progress on a discipline basis for the defined Systems.



7.8.1. START-UP Schedule and Systems Completion Schedule  
Requirements for these schedules are contained within the Planning and Scheduling Procedure.

7.8.2. Punch List Reporting  
CONTRACTOR shall prepare and maintain a databased punch-listing system that incorporates all punch list items from the start of Discipline Acceptance, to control punch lists and system exception lists as part of the process for Acceptance of the Work.

### 8.0 PROGRESS MEASUREMENT

#### 8.1 GENERAL

Throughout the duration of the WORK, CONTRACTOR shall develop, maintain, update and report against a series of progress control curves and manpower histograms. The baseline curves shall show the monthly planned vs. actual progress, which shall be generated directly from the approved

	<b>MRPL Marketing Terminal Project at Devangonhi, Bangalore</b> <b>Marketing Infrastructure Projects, MRPL</b>				
	Part – A	<b>PLANNING, SCHEDULING AND</b>  <b>MONITORING PROCEDURE</b>	Tender No :		3200000495
	Section – A-2		Document No:		20005-GEN-G- DOC-9105
Subsection – -	Rev:		1		

schedules and shall form the basis of the physical progress measurement system. During the execution of the WORK the actual monthly progress shall be compared with the planned. A forecast shall be introduced if there is any negative deviation from the plan.

## 8.2 ENGINEERING PROGRESS

Progress is a key factor in the control of engineering and procurement schedules. An accurate measurement of progress serves as a basis for office manhour forecasts as well as an indicator for performance against the project schedule and budget.

CONTRACTOR is to establish suitable computer software to track and update the status of each deliverable, with the ability to roll up progress to the respective reporting levels.

Progress (percent complete) is measured by using a weighted average method of computing “earned” hours or work units. The progress reporting system will be set up as soon as a reasonable breakdown of drawings, specifications and other activities is available for the various design disciplines.

The Control Level Schedules provide a listing/grouping of all deliverables (drawings, specifications, etc.) and activities required for the project. Estimated hours or work units are allocated to each line item, thus assigning a “weight” relative to the respective discipline control budget. By determining the “percent complete” for each item at the end of a reporting period, the earned hours are calculated as follows.

$$\text{Percent Complete} \times \text{Budget Hours} = \text{Earned hours}$$

The total earned hours from work completed, divided by the total control budget hours determines the “percent complete” or physical progress for each discipline. Utilising this same weighted average method based on “earned” hours, progress is then summarised by unit / system / discipline and total project.

### 8.2.1. Engineering Performance

Home office performance is calculated using the following formula.



$$\text{Performance} = \text{Earned hours} \div \text{Expended Hours}$$

Thus, performance is a measure of work accomplished versus actual expenditures and is calculated on both an incremental and cumulative basis at the end of each reporting period. A calculation greater than 1.00 indicates work is being performed more efficiently than that defined by the control budget, whereas a performance less than 1.00 is an indication of less efficient work. Significant Changes either way will be cause for a potential deviation.

### 8.2.2. Procurement Progress

Progress shall be a measure of the completion of each step in the procurement plan. A percentage completion shall be established for each step in the procurement chain through to delivery at the work site. The relative weightage, based on value, shall be allocated to all Equipment / Items / Materials and Bulk Material orders defined in the Material Control System. The progress for each order shall be aggregated to the appropriate summary level.

## 8.3 CONSTRUCTION PROGRESS

	<b>MRPL Marketing Terminal Project at Devangonhi, Bangalore</b> <b>Marketing Infrastructure Projects, MRPL</b>				
	Part – A	<b>PLANNING, SCHEDULING AND MONITORING PROCEDURE</b>	Tender No :		3200000495
	Section – A-2		Document No:		20005-GEN-G- DOC-9105
Subsection – -	Rev:		1		

Progress achieved is the measurement of progress on individual activities based on the achievement of interim progress milestones for the activities, and/or actual quantities of work installed by the CONTRACTOR. The milestones are a guide for progress, and credit is given to work that has progressed beyond a milestone, but has not yet achieved the next milestone. The earned values shall be accumulated by material type, plant area, to calculate actual progress percentages at the different levels of detail, with the figures rolling up to a total project actual percent complete.

## 9.0 PROGRESS REPORTING

CONTRACTOR shall prepare and issue Monthly Progress Reports and Weekly Progress Reports to inform PMC / MRPL of the status of the WORKS.

Reports shall be issued both in hard copy and electronic format.

CONTRACTOR shall report to and discuss with PMC / MRPL the status of the WORKS at Weekly Progress meetings, Monthly Progress Meetings and Review Meetings as required.

These reporting requirements shall not relieve CONTRACTOR of its obligations to promptly report to PMC / MRPL any matters that significantly affect completion of the WORK. CONTRACTOR shall provide adhoc report and/or presentations as required by PMC / MRPL to address specific issues eg. action plans to recover schedule slippage. Reports requested by PMC / MRPL and not contained within the body of the Monthly Report shall be issued either by electronic transfer or by covering transmittal.

## 9.1 MONTHLY PROGRESS REPORT



The Monthly Progress Report shall be issued to PMC / MRPL each month, with 15<sup>th</sup> calendar day of every month as cut off. Report shall be issued within 2 working days from this cutoff date. Formal monthly progress meetings will be held at which CONTRACTOR will be expected to make presentations highlighting achievements, problems and recovery measures, as recorded in the Monthly Report.

CONTRACTOR is required to prepare the report with an Executive Summary and detailed sections as defined below:

- Executive Summary
- Detailed Report
- Overall Safety / HSE
- Engineering
- Procurement Services
- Subcontracting Services
- Construction
- Pre-commissioning / Commissioning
- Quality
- Areas of Concern
- Progress Photographs

Executive Summary, shall include

- Summary narrative highlighting major activities accomplished during the month including Project Milestones achieved, progress achieved compared with plan, areas of concern and remedial actions.

	<b>MRPL Marketing Terminal Project at Devangonhi, Bangalore</b> <b>Marketing Infrastructure Projects, MRPL</b>				
	Part – A	<b>PLANNING, SCHEDULING AND MONITORING PROCEDURE</b>	Tender No :		3200000495
	Section – A-2		Document No:		20005-GEN-G- DOC-9105
Subsection – -	Rev:		1		

- Updated Project Level I schedule with analysis highlighting any delay in progress with particular reference to the project critical path and achievement of Project Milestones. Narrative shall describe any recovery actions required.
- Safety summary reporting achievements in the month, current objectives, and incident/accident statistics in a format to be agreed with MRPL's HSE department. Any serious incidents, results of investigations and remedial actions should be addressed in this section.
- Summary Progress Reports comprising;
  - Progress S-Curves updated with actual versus plan
  - Manpower histograms updated with actual versus plan
  - Quantity Reporting Summary showing the relevant key progress indicators for the stage of the project (refer below)
  - Summary status and progress for each subcontract
  - Summary of CONTRACT changes

Detailed Report, shall include

Each Detailed Report section shall contain a narrative of the major activities undertaken during the month, planned activities for the next month, areas of concern and recovery actions.

CONTRACTOR shall provide the following specific progress reports, with the respective sections:

#### 9.1.1. HSE

This section will highlight the activities in the area of HSE, and shall address key activities that have taken place during the month

- Narrative addressing for the month, actions taken to enhance and encourage HSE awareness.
- Tabulation of SITE HSE statistics, by subcontractor, in a format to be agreed with MRPL's HSE department.
- Statement of overall accident-free manhours for the WORKS.

#### 9.1.2. Engineering Services



- Summary status for engineering deliverables, represented as a comparison of the number of deliverables planned/actual/forecast. Broken down by discipline and type, the number of deliverables shall be shown for each key step in the development and approval process.
- Progress curves and manpower histograms for overall engineering and each major discipline, showing planned, actual and forecast progress.

#### 9.1.3. Procurement and Subcontracting Services

- Summary status for equipment and materials, represented as a comparison of the number of purchase orders planned/actual/forecast.
- Progress curves for overall Procurement Services, and split by equipment/bulks, showing planned, actual and forecast progress.
- Progress curves for overall Subcontracting Services.

#### 9.1.4. Construction

- Summary progress by major discipline and subcontract
- Progress curves for overall Construction, and for each area and subcontract, showing planned, actual and forecast progress.

	<b>MRPL Marketing Terminal Project at Devangonhi, Bangalore</b> <b>Marketing Infrastructure Projects, MRPL</b>				
	Part – A	<b>PLANNING, SCHEDULING AND</b>  <b>MONITORING PROCEDURE</b>	Tender No :		3200000495
	Section – A-2		Document No:		20005-GEN-G- DOC-9105
Subsection – -	Rev:		1		

- Construction manpower histograms, indicating direct/indirect labour, and plan versus actual, each subcontract.

#### 9.1.5. Pre-Commissioning/Commissioning

- Summary status by system showing the key stages of each system as it progresses from MC to RFSU.
- Progress curves for PRECOMMISSIONING and COMMISSIONING activities showing planned, actual and forecast progress.

## 9.2 PROJECT CONTROLS

This section shall address planning matters, with particular reference to the overall Project Schedule. The cut-off date to be used in the preparation of data shall be as per the Project calendar.

### 9.2.1. Planning

- Narrative summary of the overall Project Schedule status with particular reference to slippages, critical path activities and other areas of Schedule sensitivity.
- Overall progress summary, curves and histograms for the WORKS, Engineering, Procurement & Subcontracting, Construction, Pre Commissioning & Commissioning, As Built and Project Closure. Planned, actual and forecast progress shall be shown.
- Contract Master Schedule, updated for progress through the report period.
- MILESTONE status showing Scheduled/actual/forecast dates.

### 9.2.2. Quality

This Section will highlight activities in the area of Quality Control (QC) and Quality Assurance (QA) for engineering, procurement and field activities.

- Status of Audits
- Quality Control Report showing main activities, statistics and disposition of Non-Compliance Reports (NCR)
- Status of key QC indications, eg. compaction tests, concrete tests, NDE results (including welder qualification records and performance/rejection rates), pressure tests etc.

### 9.2.3. Areas of Concern

- Narrative of major areas of concern facing the Project, plus CONTRACTOR's proposed courses of action.
- Status of outstanding areas of concern and those cleared since the previous month's report.



### 9.2.4. Progress Photographs and 3D CAD views

CONTRACTOR shall take regular photographs of the WORKS as a record of its progress within the Monthly Report. Photographs shall be taken every month at a minimum of six locations to be directed by PMC / MRPL.

## 9.3 WEEKLY PROGRESS REPORT

The weekly progress report shall be submitted to PMC / MRPL on the first working day of the following week. The minimum contents shall be as follows:

- Brief narratives of the activities performed during the week by each discipline or in the case of construction each subcontract, with highlights on specific achievements.
- Areas of concern and proposed corrective action.
- Construction reporting shall include, equipment and bulk materials received, tables indicating planned and actual quantities for key construction indicators eg steelwork erected, equipment erection, piping erection, electric cable installed.

	<b>MRPL Marketing Terminal Project at Devangonhi, Bangalore</b> <b>Marketing Infrastructure Projects, MRPL</b>				
	Part – A	<b>PLANNING, SCHEDULING AND</b>  <b>MONITORING PROCEDURE</b>	Tender No :		3200000495
	Section – A-2		Document No:		20005-GEN-G- DOC-9105
Subsection – -	Rev:		1		

- Weekly man-hour summary table showing Home Office manhours expended for the week and actual manpower, or in the case of construction each subcontractors manhours expended for the week, to date, and actual site manpower.
- Major activities planned for next week.
- List of outstanding documents and correspondence requiring response by either PMC / MRPL or CONTRACTOR.

#### 9.4 DAILY CONSTRUCTION REPORTS

CONTRACTOR shall maintain a daily field log sheet giving a brief description of the WORK in progress. CONTRACTOR shall provide daily labour and equipment sheets detailing CONTRACTOR's, Subcontractors and vendors equivalent direct and indirect staffing by trade and major construction equipment employed, material received, key milestones achieved, lost time accidents and other major activities of the day.

#### 9.5 FINAL CLOSE-OUT REPORT

CONTRACTOR shall prepare a Final Close-out Report for the Works which shall be submitted to PMC / MRPL no later than one month after Provisional Acceptance. The format of the Final Close-out Report is to be agreed with PMC / MRPL no later than six (6) months prior to the planned Provisional Acceptance.

#### 9.6 PROGRESS MEETINGS

CONTRACTOR shall report to and discuss with PMC / MRPL the status of the Project Progress at Weekly Progress Meetings and Monthly Progress Meetings.

#### 9.7 WEEKLY PROGRESS MEETINGS

The main purpose of the Weekly Progress Meeting shall be to discuss the Weekly Progress Report. Particular attention shall be directed towards any recovery actions required. Other topics may be introduced at the request of PMC / MRPL or CONTRACTOR. The location, timing, attendees and agenda shall be agreed with PMC / MRPL.

#### 9.8 MONTHLY PROGRESS MEETINGS

The main purpose of the Monthly Progress Meeting shall be to discuss the Monthly Progress Report. Other topics may be introduced at the request of PMC / MRPL or CONTRACTOR. The location, timing, attendees and agenda shall be agreed with PMC / MRPL.

#### 9.9 SUBCONTRACTORS' AND VENDORS' PROGRESS MEETINGS

PMC / MRPL has the right to attend all progress meetings with Subcontractors' and Vendors' and shall be notified of such meetings and receive a copy of the minutes within four (4) working days of the meeting.



#### 9.10 RECORDS

CONTRACTOR shall maintain records of all weekly and monthly progress report statistics and supporting databases which shall be available to PMC / MRPL personnel.

#### 10.0 PROGRESS REVIEW CERTIFICATION

##### 10.1 PROGRESS DOCUMENTATION

CONTRACTOR shall perform progress measurement in accordance with Progress Planning Section 6.0. CONTRACTOR shall submit all supporting documentation for the progress claimed each month, to enable progress certification / approval by PMC / MRPL. Progress Review / Verification sheets to be submitted by CONTRACTOR shall cover the details of progress achieved during the month as per the details given below.

	<b>MRPL Marketing Terminal Project at Devangonhi, Bangalore</b> <b>Marketing Infrastructure Projects, MRPL</b>			
	Part – A	<b>PLANNING, SCHEDULING AND</b>  <b>MONITORING PROCEDURE</b>		Tender No : 3200000495
	Section – A-2			Document No: 20005-GEN-G-DOC-9105
Subsection – -	Rev: 1			

1. Physical Progress and Milestone Completion Certificate
2. Milestone Certificate
3. Milestone Summary Status
4. Overall Progress Summary
5. Engineering Progress
6. Procurement Progress
7. Subcontracting Progress
8. Construction Progress
9. Commissioning Progress

Above details shall be submitted every month for progress certification as per the enclosed sample formats, Attachments 17 to 23. CONTRACTOR shall ensure that the MILESTONES achieved during the month are agreed by PMC / MRPL prior to submission of above details for progress certification.

## 10.2 REVIEW AND CERTIFICATION

PMC / MRPL shall return the above progress verification sheets to CONTRACTOR duly approved / certified, within 10 working days after receipt of same by PMC / MRPL with correct details. In case any portion of the progress claimed to have been achieved is found to be incorrect, the same shall be communicated by PMC / MRPL to the CONTRACTOR within 10 working days after receipt by PMC / MRPL, for necessary rectification and resubmission of above documents.

## 11.0 SCHEDULE CHANGE

### 11.1 PROCEDURE

This procedure defines the system for identification of potential changes and approval of Schedule changes. Changes are to be prepared for events that potentially impact the cost, schedule and / or have detrimental impact on quality.

### 11.2 CHANGE IDENTIFICATION

#### 11.2.1. Contractor Identified Changes

CONTRACTOR is required to promptly notify PMC / MRPL of potential changes to the CONTRACT scope through the Schedule Change system. CONTRACTOR documents the Schedule change, recording the change basis and change impacts on manhours, cost and schedule. The originator should clearly describe the Change and provide backup and reference documents including the relevant portion of the project specification that is affected. CONTRACTOR must notify PMC / MRPL of a Change within ten (10) working days of identification.

If during performance of services, CONTRACTOR is of the opinion that any instruction received from PMC / MRPL or any other developments affecting the services should be treated as a variation, CONTRACTOR shall notify PMC / MRPL in writing within five (5) days and shall await PMC / MRPL's further instructions.



#### 11.2.2. PMC / MRPL Initiated Trend

PMC / MRPL initiated changes will be communicated to CONTRACTOR under a Change Note. CONTRACTOR shall prepare the full Change assessment and submit for PMC / MRPL's review within ten (10) working days after receipt.

CONTRACTOR shall provide information on cost, schedule etc. on these Change Notes.

#### 11.2.3. Cost of Trend Preparation



 <b>ONGC</b> एन.ओ.ए.सी.एल. <b>MRPL</b>	<b>MRPL Marketing Terminal Project at Devangonhi, Bangalore</b> <b>Marketing Infrastructure Projects, MRPL</b>			 <b>nauvata</b> PROJECT MANAGEMENT SOLUTIONS	
	Part – A	<b>PLANNING, SCHEDULING AND</b>  <b>MONITORING PROCEDURE</b>	Tender No :		3200000495
	Section – A-2		Document No:		20005-GEN-G- DOC-9105
Subsection – -	Rev:		1		

The full cost of evaluating and processing of a Change notes, whether ultimately approved or rejected by PMC / MRPL shall be borne by the CONTRACTOR and shall not be reimbursed by PMC / MRPL.

#### 11.2.4. Schedule Effects

The trend section applicable to schedule will be completed by CONTRACTOR. CONTRACTOR shall endeavor to maintain the schedule as contained in the Baseline schedule.

In the event of a potential schedule deviation, CONTRACTOR shall evaluate the extent of change in any Milestone and/or Overall Completion Date.

PMC / MRPL requires CONTRACTOR to provide all relevant schedule data, related to the change, in order to demonstrate that the work cannot be executed within the agreed time frame. CONTRACTOR shall supply PMC / MRPL with a CPM Network including the basis for original and revised logic and durations.

#### 11.3 PMC / MRPL ASSESSMENT

PMC / MRPL will perform an assessment of all Change Notes and raise clarifications to the CONTRACTOR if required. PMC / MRPL will then either, approve the Change Note and proceed to issue a Variation, or notify the change Note is rejected.

#### 11.4 IMPLEMENT CHANGE

When CONTRACTOR has been notified of a Change, CONTRACTOR's Project Management will instruct the task force to proceed. CONTRACTOR will update the Change Log and revise the reports.

1

1

1









Part - A  
Section - A-2  
Subsection - -

MRPL Marketing Terminal Project at Devangonhi, Bangalore  
Marketing Infrastructure Projects, MRPL

PLANNING, SCHEDULING AND MONITORING PROCEDURE

TENDER NO.  
DOCUMENT NO.  
REV.

3200000495  
20005-GEN-G-DOC-9105  
1

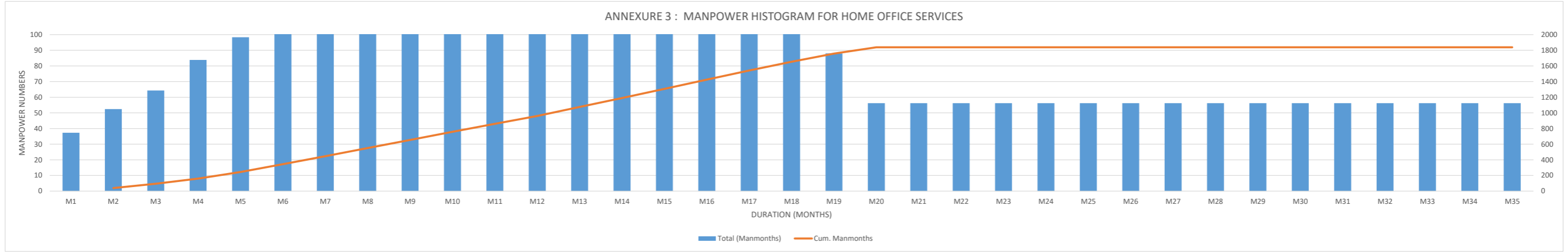

Description	M1	M2	M3	M4	M5	M6	M7	M8	M9	M10	M11	M12	M13	M14	M15	M16	M17	M18	M19	M20	M21	M22	M23	M24	M25	M26	M27	M28	M29	M30	M31	M32	M33	M34	M35	Total Manmonths	Total Manhours
Project Management Services	3	6	6	6	6	6	6	6	6	6	6	6	6	6	6	6	6	6	6	6	6	6	6	6	6	6	6	6	6	6	6	6	6	6	6		
Engineering Services	27.2	31.1	40	50	60	60	60	60	60	60	60	70	70	70	70	65	60	50	30	30	30	30	30	30	30	30	30	30	30	30	30	30	30	30	30		
Procurement Services		2	4	6	6	8	8	8	8	8	8	8	8	8	8	8	8	8	8	0.2	0.2	0.2	0.2	0.2	0.2	0.2	0.2	0.2	0.2	0.2	0.2	0.2	0.2	0.2	0.2		
Contracting Services	0	0	0	2	3	4	4	4	4	4	4	4	4	4	6	6	6	6	6	4	4	4	4	4	4	4	4	4	4	4	4	4	4	4	4		
Construction & Commissioning Services	0.1	0.1	1.1	1.5	3	4	6	6	6	3	3	3	3	3	3	3	3	3	0	0	0	0	0	0	0	0	0	0	0	0	0	0	0	0	0		
Design/ Drafting Services	4	10	10	14	16	16	16	16	16	16	16	18	18	18	18	18	18	16	16	12	12	12	12	12	12	12	12	12	12	12	12	12	12	12	12		
Document Control Services	2	3	3	4	4	4	4	4	4	4	4	6	6	6	6	6	6	6	4	4	4	4	4	4	4	4	4	4	4	4	4	4	4	4	4		
Other services	1	0.2	0.2	0.3	0.3	0.3	0	0	2.3																												
<b>Total (Manmonths)</b>	<b>37.3</b>	<b>52.4</b>	<b>64.3</b>	<b>83.8</b>	<b>98.3</b>	<b>102.3</b>	<b>104</b>	<b>104</b>	<b>106.3</b>	<b>101</b>	<b>101</b>	<b>115</b>	<b>115</b>	<b>117</b>	<b>117</b>	<b>112</b>	<b>105</b>	<b>88</b>	<b>56.2</b>	<b>56.2</b>	<b>56.2</b>	<b>56.2</b>	<b>56.2</b>	<b>56.2</b>	<b>56.2</b>	<b>56.2</b>	<b>56.2</b>	<b>56.2</b>	<b>56.2</b>	<b>56.2</b>	<b>56.2</b>	<b>56.2</b>	<b>56.2</b>	<b>56.2</b>			
<b>Total (Manhours)</b>	<b>6681</b>	<b>9248</b>	<b>11271</b>	<b>14246</b>	<b>17051</b>	<b>17391</b>	<b>17680</b>	<b>17680</b>	<b>17680</b>	<b>17170</b>	<b>17170</b>	<b>19550</b>	<b>19550</b>	<b>19890</b>	<b>19890</b>	<b>19890</b>	<b>19040</b>	<b>17850</b>	<b>13600</b>	<b>13600</b>	<b>13600</b>	<b>13600</b>	<b>13600</b>	<b>13600</b>	<b>13600</b>	<b>13600</b>	<b>13600</b>	<b>13600</b>	<b>13600</b>	<b>13600</b>	<b>13600</b>	<b>13600</b>	<b>13600</b>	<b>13600</b>			
<b>Cum. Manmonths</b>		<b>39.3</b>	<b>93.7</b>	<b>160</b>	<b>243.8</b>	<b>344.1</b>	<b>446.4</b>	<b>550.4</b>	<b>654.4</b>	<b>758.4</b>	<b>859.4</b>	<b>960.4</b>	<b>1075</b>	<b>1190</b>	<b>1307</b>	<b>1424</b>	<b>1541</b>	<b>1653</b>	<b>1758</b>	<b>1838</b>	<b>1838</b>	<b>1838</b>	<b>1838</b>	<b>1838</b>	<b>1838</b>	<b>1838</b>	<b>1838</b>	<b>1838</b>	<b>1838</b>	<b>1838</b>	<b>1838</b>	<b>1838</b>	<b>1838</b>	<b>1838</b>			

The above is indicative only. Contractor may modify the list as per the Project scope and requirements





Part – A  
Section – A-2  
Subsection – -

MRPL Marketing Terminal Project at Devangonhi, Bangalore  
Marketing Infrastructure Projects, MRPL

PLANNING, SCHEDULING AND MONITORING PROCEDURE

TENDER NO.  
DOCUMENT NO.  
REV.

3200000495  
20005-GEN-G-DOC-9105  
1

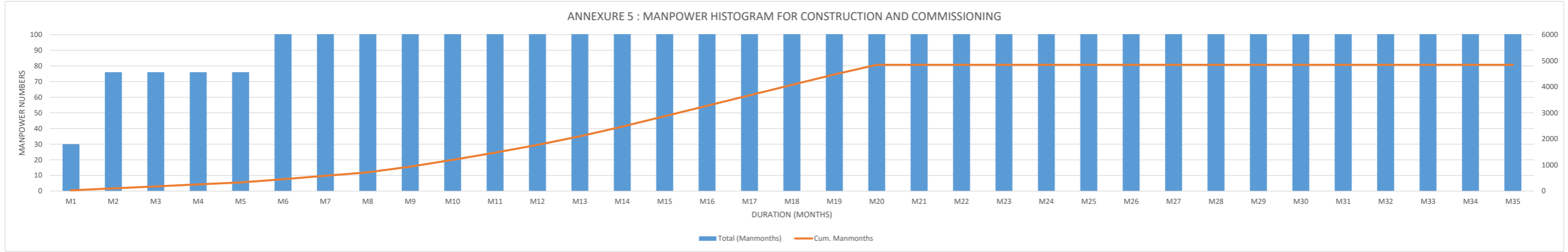

Description	M1	M2	M3	M4	M5	M6	M7	M8	M9	M10	M11	M12	M13	M14	M15	M16	M17	M18	M19	M20	M21	M22	M23	M24	M25	M26	M27	M28	M29	M30	M31	M32	M33	M34	M35	Total Manmonths	Total Manhours	
Direct Manpower Nos ( Field Supervision Staff )	5	15	15	15	15	20	20	20	40	40	40	40	50	50	50	50	50	50	50	50	50	50	50	50	50	50	50	50	50	50	50	50	50	50	50	1435		
Indirect Manpower Nos ( Field Supervision Staff )	1	3	3	3	3	4	4	4	8	8	8	8	10	10	10	10	10	10	10	10	10	10	10	10	10	10	10	10	10	10	10	10	10	10	10	10	287	
Direct Manpower Nos ( Non Supervisory Staff )	20	50	50	50	50	70	75	80	120	140	160	180	200	220	250	250	250	250	250	250	250	250	250	250	250	250	250	250	250	250	250	250	250	250	250	250	6715	
Subcontractor Manpower Nos	0	0	0	0	0	20	20	20	40	60	60	60	60	80	80	80	80	80	80	50	50	50	50	50	50	50	50	50	50	50	50	50	50	50	50	50	1620	
Other Manpower Nos	4	8	8	8	8	10	10	10	10	10	10	10	10	10	10	10	10	10	10	10	10	10	10	10	10	10	10	10	10	10	10	10	10	10	10	336		
<b>Total (Manmonths)</b>	<b>30</b>	<b>76</b>	<b>76</b>	<b>76</b>	<b>76</b>	<b>124</b>	<b>129</b>	<b>134</b>	<b>218</b>	<b>258</b>	<b>278</b>	<b>298</b>	<b>330</b>	<b>370</b>	<b>400</b>	<b>400</b>	<b>400</b>	<b>400</b>	<b>400</b>	<b>370</b>	<b>370</b>	<b>370</b>	<b>370</b>	<b>370</b>	<b>370</b>	<b>370</b>	<b>370</b>	<b>370</b>	<b>370</b>	<b>370</b>	<b>370</b>	<b>370</b>	<b>370</b>	<b>370</b>	<b>370</b>	<b>10393</b>		
<b>Total (Manhours)</b>	<b>6600</b>	<b>16720</b>	<b>16720</b>	<b>16720</b>	<b>16720</b>	<b>27280</b>	<b>28380</b>	<b>29480</b>	<b>47960</b>	<b>56760</b>	<b>61160</b>	<b>65560</b>	<b>72600</b>	<b>81400</b>	<b>88000</b>	<b>88000</b>	<b>88000</b>	<b>88000</b>	<b>88000</b>	<b>81400</b>	<b>81400</b>	<b>81400</b>	<b>81400</b>	<b>81400</b>	<b>81400</b>	<b>81400</b>	<b>81400</b>	<b>81400</b>	<b>81400</b>	<b>81400</b>	<b>81400</b>	<b>81400</b>	<b>81400</b>	<b>81400</b>	<b>81400</b>			
<b>Cum. Manmonths</b>	<b>30</b>	<b>106</b>	<b>182</b>	<b>258</b>	<b>334</b>	<b>458</b>	<b>587</b>	<b>721</b>	<b>939</b>	<b>1197</b>	<b>1475</b>	<b>1773</b>	<b>2103</b>	<b>2473</b>	<b>2873</b>	<b>3273</b>	<b>3673</b>	<b>4073</b>	<b>4473</b>	<b>4843</b>	<b>4843</b>	<b>4843</b>	<b>4843</b>	<b>4843</b>	<b>4843</b>	<b>4843</b>	<b>4843</b>	<b>4843</b>	<b>4843</b>	<b>4843</b>	<b>4843</b>	<b>4843</b>	<b>4843</b>	<b>4843</b>	<b>4843</b>			

The above is indicative only. Contractor may modify the list as per the Project scope and requirements





Part – A  
Section – A-2  
Subsection – -

MRPL Marketing Terminal Project at Devangonhi, Bangalore  
Marketing Infrastructure Projects, MRPL

PLANNING, SCHEDULING AND MONITORING PROCEDURE

TENDER NO.  
DOCUMENT NO.  
REV.

3200000495  
20005-GEN-G-DOC-9105  
1



ATTACHMENT 7: ENGINEERING DOCUMENT AND DELIVERABLE REGISTER

Sl. No.	WBS Number	Discipline	Document Number	Document Description	Document Category / Class	Weightage (%)	Plan / Act / For	Start	Draft Complete	Issue for IDC	IDC Complete	Issue for PMC / MRPL review	Receive PMC / MRPL Comments	Issue for PMC / MRPL Approval	Receive PMC / MRPL Approval	Issue as AFC / IFC	Earned Progress	Plan (%)	Act (%)	Remarks		
Incremental Progress (%)																						
Cumulative Progress (%)																						
							Plan															
							Act															
							For															
							Plan															
							Act															
							For															
							Plan															
							Act															
							For															
							Plan															
							Act															
							For															

Note:

- a All Engineering Deliverables such as Drawings, Reports, Specifications, Datasheets, etc. shall be listed using this template.
- b All Bulk Quantities (MTOs) shall be listed using this template
  - i. Preliminary MTO (1st Issue) shall be indicated under "Issue for PMC / MRPL review" column
  - ii. Intermediate MTO (2nd Issue) shall be included under "Issue for PMC / MRPL Approval" column
  - iii. Final MTO (3rd Issue) shall be included under "Issue as AFC / IFC"column







Part - A  
Section - A-2  
Subsection - -

MRPL Marketing Terminal Project at Devangonhi, Bangalore  
Marketing Infrastructure Projects, MRPL

PLANNING, SCHEDULING AND MONITORING PROCEDURE

TENDER NO.  
DOCUMENT NO.  
REV.

3200000495  
20005-GEN-G-DOC-9105  
1



**ATTACHMENT 9: PROCUREMENT SERVICES STATUS REGISTER**

Sl. No.	WBS Number	Discipline	Document / PO Number	Item / Material / Equipment Description	Weightage (%)	Plan / Act / For	Start RFQ / MR	Issue MR / RFQ to Vendors	Receive Vendor Offers	TQ / TQ Closure	Issue TBE for PMC / MRPL review	Receive PMC / MRPL Comments on TBE	Issue Final TBE	Vendor Nomination	Issue PS for PMC / MRPL review	Receive PMC / MRPL Comments on PS	Issue Final PS	Place PO on Vendor	Pre-Inspection Meeting	Receive & Approve Vendor Drawings	Ready for Inspection	FAT	Closure of Punch Points	Dispatch from Vendor's Premis	Receipt of Material at Site	Earned Progress	Plan (%)	Act (%)	Remarks	
<b>Incremental Progress (%)</b>																														
<b>Cumulative Progress (%)</b>																														
						Plan																								
						Act																								
						For																								
						Plan																								
						Act																								
						For																								
						Plan																								
						Act																								
						For																								
						Plan																								
						Act																								
						For																								

Note:  
a Weightages shall be based on the estimated cost of each item / material / equipment





Part – A  
Section – A-2  
Subsection – -

MRPL Marketing Terminal Project at Devangonhi, Bangalore  
Marketing Infrastructure Projects, MRPL

PLANNING, SCHEDULING AND MONITORING PROCEDURE

TENDER NO. 3200000495  
DOCUMENT NO. 20005-GEN-G-DOC-9105  
REV. 1



ATTACHMENT 11: SUBCONTRACTING SERVICES STATUS REGISTER

Sl. No.	Discipline	Item Description	Weightage (%)	Plan / Act / For	Finalise Bidders List		Issue Tender for Bid	Receive Bids	Submit Bid Evaluation to Company	Receive Company Approval	Award Sub Contract	Earned Progress	Plan (%)	Act (%)	Contractor's Name	Contract Completion Date	Remarks		
					Submission	Approval													
Incremental Progress (%)																			
Cumulative Progress (%)																			
				Plan															
				Act															
				For															
				Plan															
				Act															
				For															
				Plan															
				Act															
				For															
				Plan															
				Act															
				For															



Notes:

a Weightages shall be based on the estimated manhours of each subcontract







	<b>MRPL Marketing Terminal Project at Devangonhi, Bangalore</b> <b>Marketing Infrastructure Projects, MRPL</b>				
	Part – A	<b>PLANNING, SCHEDULING AND</b>  <b>MONITORING</b>	Tender No :		3200000495
	Section – A-2		Document No:		20005-GEN-G- DOC-9105
Subsection – -	Rev:		1		



Attachment 15  
Guideline on Progress Measurement System for Construction

A Typical Example is as below.

This example illustrates the various progress levels interacting to formulate an overall progress figure, the lowest levels, levels 5 and below, will generally utilize standardised weightings that will be formulated in the manner shown below.

Level 1	Level 2	Level 3	Level 4	Level 5	Weightage (%)
Overall Construction					100%
	Main Construction				92%
		Civil			
		Structural			
		Piping			
		Mechanical			
			Tanks		
				Bottom Plates	
				Shell	
				Roof	
			Pumps		
			Miscellaneous Equipments		
		Electrical			
		Instrumentation			
	Pre Commissioning				3%
	Commissioning				3%
	As Built / Closeout				2%

General guidelines on weighting stages for level 5 and lower  
CONTRACTOR will develop progress weighting system for further levels (Level 5 onwards). CONTRACTOR will submit the proposed weightings for EMPLOYER review and approval prior to implementation. Weight factors for Level 5 onwards shall reflect Measurable Elements of works for each type of work. The Measurable Elements shall be weighted by manhours for each category of

	<b>MRPL Marketing Terminal Project at Devangonhi, Bangalore</b> <b>Marketing Infrastructure Projects, MRPL</b>				
	Part – A	<b>PLANNING, SCHEDULING AND</b>  <b>MONITORING</b>	Tender No :		3200000495
	Section – A-2		Document No:		20005-GEN-G- DOC-9105
Subsection – -	Rev:		1		

work to enable aggregation to the summary progress reporting levels.

The work volume of each Progress Measurable element shall be measured using appropriate Yard Sticks. Physical progress of the Work Element shall be obtained by dividing the work volume completed by the estimated total work volume. Typical examples of yard sticks are as below.

- number of piles installed
- m length of buried linepipe installed
- m<sup>3</sup> of concrete poured
- m<sup>3</sup> of soil excavated
- m length of trenching completed
- m<sup>2</sup> of paving
- tonnage of steelwork fabricated
- tonnage of steelwork erected
- number of pipe welds complete (qty or dia/ins)
- number, tonnage and meters of spools fabricated
- number, tonnage and metres of spools installed, straight pipe installed,
- number of field welds complete split by large bore, small bore, under and above ground.
- number and diametric millimetres of welds, by material type, passed and failed.
- number of equipment items installed.
- number of instruments and control elements installed and connected.
- m cable length installed and connected.
- m cable tray/rack installed
- metres of steam/electric tracing installed.
- number of hydrostatic tests complete.
- Number of systems flushed and reinstated.
- m<sup>3</sup> or m<sup>2</sup> of pipe length insulated.
- m<sup>2</sup> of area painted.
- number of loop checks completed



Some examples of level 5 progress stages

CONTRACTOR shall establish planned installation curves for the major categories of WORK as follows, based on the detailed schedule. During the construction phase, CONTRACTOR shall measure the physical progress made for its WORK and that of SUBCONTRACTORS

Equipment Foundation	
Excavation	15%
Formwork / rebar	40%
Concreting	40%
Strip Formwork &	5%
	100%

Building / Superstructure Concreting	
Formwork / rebar	60%
Concreting	35%
Removal of Formwork	5%
	100%



	<b>MRPL Marketing Terminal Project at Devangonhi, Bangalore</b> <b>Marketing Infrastructure Projects, MRPL</b>				
	Part – A	<b>PLANNING, SCHEDULING AND</b>  <b>MONITORING</b>	Tender No :		320000495
	Section – A-2		Document No:		20005-GEN-G- DOC-9105
Subsection – -	Rev:		1		

Drainage	
Precast manholes	35%
Place manholes	15%
Drainage	50%
	100%

Precast Cable Trenches	
Precast Units	30%
Install precast units	20%
Completed Trench in precast	50%
	100%



Rotating Equipment Installation	
Install	15%
Level / Align	25%
Grout	15%
Coupling / Guards	35%
Testing & Precommissioning	10%
	100%

Spooled Piping	
Fabrication	30%
Erection	30%
Weld out / bolt up	10%
Supports	5%
Testing	15%
Reinstatement	5%
Final Inspection	5%
	100%

Electrical Cabling	
Cable Laying / Pulling	60%
Termination	35%
Testing	5%
	100%



#### Construction Progress Evaluation

CONTRACTOR shall report each month both the productivity in terms of expended jobhours per unit of each WORK item installed and the actual quantity achievement against the quantity planned for each of the major categories of WORK. Performance factors, based on earned (or achieved) jobhours divided by actual (or expended) jobhours, shall be used by CONTRACTOR to demonstrate the performance of the WORK and to substantiate that adequate manning levels are being provided to meet the WORK schedule.

	<b>MRPL Marketing Terminal Project at Devangonhi, Bangalore</b> <b>Marketing Infrastructure Projects, MRPL</b>				
	Part – A	<b>PLANNING, SCHEDULING AND</b>  <b>MONITORING</b>	Tender No :		3200000495
	Section – A-2		Document No:		20005-GEN-G- DOC-9105
Subsection – -	Rev:		1		

Attachment 16  
Construction Quantities

Craft	Document Type	Units	Total Quantity	Installed Quantities			
				For the Month		Cumulative till Date	
				Planned	Actual	Planned	Actual
Piling	Piling	No.					
Civil	Concrete	m <sup>3</sup>					
	Paving	m <sup>2</sup>					
	Concrete Structures	Tons					
	Steel Fabricated	Tons					
	Steel Installed	Tons					
Mechanical / Piping	U/G Piping	LM					
	Spools Fabricated	No.					
	Spools Fabricated	DI					
	Spools Fabricated	LM					
	Spools Installed	No.					
	Spools Installed	LM					
	Straight Pipe Installed	No.					
	Straight Pipe installed	LM					
	Field Weld – Underground	No.					
	Field Weld – Large Bore	No.					
	Hydrostatic Tests	No.					
	Equipment Installed	No.					
Electrical / Instrumentation	Instruments / Controls Installed	No.					
	Terminations	No.					
	Cable Tray	LM					
	Cable	LM					
Others	Systems Flushed	No.					
	Systems Re-instated	No.					
	Pipe Length Insulated	m <sup>2</sup>					
	Area Painted	m <sup>2</sup>					

	<b>MRPL Marketing Terminal Project at Devangonhi, Bangalore</b> <b>Marketing Infrastructure Projects, MRPL</b>				
	Part – A	<b>PLANNING, SCHEDULING AND</b>  <b>MONITORING</b>	Tender No :		3200000495
	Section – A-2		Document No:		20005-GEN-G- DOC-9105
Subsection – -	Rev:		1		

Attachment 17  
Physical Progress and Milestone Completion Certificate

Project Number				
Project Name				
Month				Invoice No.
Invoicing Period		Upto		Date

A. PHYSICAL PROGRESS

Description	Monthly Progress (%)	Cumulative Progress (%)
Progress Planned		
Progress Achieved (Actual)		
Variance = Plan – Actual		

B. MILESTONE SCHEDULE

1. \*MILESTONE SCHEDULED FOR COMPLETION DURING INVOICING MONTH

Milestone Reference	Description	Date Achieved	Transmittal Number	# Not Achieved or Comments

2. \*PRIOR MONTHS MILESTONES ACHIEVED DURING INVOICING MONTH

Milestone Reference	Description	Date Achieved	Transmittal Number	# Not Achieved or Comments

3. \*MILESTONES OUTSTANDING FROM PREVIOUS MONTHS

Milestone Reference	Description	Date Achieved	Transmittal Number	# Not Achieved or Comments

The above Milestones and Stated Approved Physical Progress are Confirmed as Correct.



\_\_\_\_\_  
Contractor

\_\_\_\_\_  
PMC / MRPL

**Notes**

\*ADDITIONAL SHEETS TO BE USED IF NECESSARY

#COMPLETE IF APPLICABLE

	<b>MRPL Marketing Terminal Project at Devangonhi, Bangalore</b> <b>Marketing Infrastructure Projects, MRPL</b>				
	Part – A	<b>PLANNING, SCHEDULING AND</b>  <b>MONITORING</b>	Tender No :		3200000495
	Section – A-2		Document No:		20005-GEN-G- DOC-9105
Subsection – -	Rev:		1		

Attachment 18  
Milestone Certificate

Project Number	
Project Name	
<b><u>MILESTONE CERTIFICATE</u></b>	
Milestone Number	
Description	
Date Planned	
Date Achieved	

\_\_\_\_\_  
Contractor

\_\_\_\_\_  
PMC / MRPL

\_\_\_\_\_  
Date

\_\_\_\_\_  
Date





Part – A  
Section – A-2  
Subsection – -

MRPL Marketing Terminal Project at Devangonhi, Bangalore  
Marketing Infrastructure Projects, MRPL

PLANNING, SCHEDULING AND MONITORING PROCEDURE

TENDER NO. 3200000495  
DOCUMENT NO. 20005-GEN-G-DOC-9105  
REV. 1



ATTACHMENT 20: OVERALL PROGRESS SUMMARY

Project Number	
Project Description	

Month	
Cutoff Date	

CATEGORY	WEIGHTAGE (%)	CUMULATIVE PROGRESS (%)		INCREMENTAL/ MONTH PROGRESS (%)		CERTIFIED		REMARKS
		PLAN	ACTUAL	PLAN	ACTUAL	BY	SIGN	
PROJECT MANAGEMENT & GENERAL								
ENGINEERING								
PROCUREMENT & SUBCONTRACTING								
CONSTRUCTION								
PRE COMMISSIONING & COMMISSIONING								
AS BUILT DOCUMENTATION								
PROJECT CLOSURE								
<b>OVERALL</b>								

APPROVED BY	
SIGN	
NAME	
DATE	



Part – A  
Section – A-2  
Subsection – -

MRPL Marketing Terminal Project at Devangonhi, Bangalore  
Marketing Infrastructure Projects, MRPL

PLANNING, SCHEDULING AND MONITORING PROCEDURE

TENDER NO. 3200000495  
DOCUMENT NO. 20005-GEN-G-DOC-9105  
REV. 1



**ATTACHMENT 21: ENGINEERING PROGRESS SUMMARY**

Project Number	
Project Description	

Month	
Cutoff Date	

DESCRIPTION	WEIGHTAGE (%)	CUMULATIVE PROGRESS (%)		INCREMENTAL/ MONTH PROGRESS (%)		REVIEWED		REMARKS
		PLAN	ACTUAL	PLAN	ACTUAL	BY	SIGN	
GENERAL								
PROCESS								
SAFETY (HSE)								
PIPING								
CIVIL / STRUCTURAL / ARCHITECTURAL								
MECHANICAL								
ELECTRICAL								
INSTRUMENTATION								
TELECOMMUNICATION								
PIPELINES								
<b>OVERALL ENGINEERING</b>								

CERTIFIED BY	
SIGN	
NAME	
DATE	



Part – A  
Section – A-2  
Subsection – -

MRPL Marketing Terminal Project at Devangonhi, Bangalore  
Marketing Infrastructure Projects, MRPL

PLANNING, SCHEDULING AND MONITORING PROCEDURE

TENDER NO. 3200000495  
DOCUMENT NO. 20005-GEN-G-DOC-9105  
REV. 1



**ATTACHMENT 22: PROCUREMENT / SUBCONTRACTING PROGRESS SUMMARY**



Project Number		Month	
Project Description		Cutoff Date	

DESCRIPTION	WEIGHTAGE (%)	CUMULATIVE PROGRESS (%)		INCREMENTAL/ MONTH PROGRESS (%)		REVIEWED		REMARKS
		PLAN	ACTUAL	PLAN	ACTUAL	BY	SIGN	
GENERAL								
PROCESS								
SAFETY (HSE)								
PIPING								
CIVIL / STRUCTURAL / ARCHITECTURAL								
MECHANICAL								
ELECTRICAL								
INSTRUMENTATION								
TELECOMMUNICATION								
PIPELINES								
<b>OVERALL ENGINEERING</b>								

CERTIFIED BY	
SIGN	
NAME	
DATE	





	<b>MRPL Marketing Terminal Project at Devangonhi, Bangalore</b> <b>Marketing Infrastructure Projects, MRPL</b>				
	Part – C	<b>DATASHEET FOR</b>  <b>HSD TANKS</b>	Tender No. :		3200000495
	Section – C-3		Doc No.:		20005-GEN-M-DS-4026
Subsection – C-3.41	Rev :		1		

<b>C-3</b>	<b>SPECIFICATIONS AND DATASHEETS</b>
<b>C-3.41</b>	<b>DATASHEET FOR HSD TANKS</b>

## MRPL Marketing Terminal Project at Devangonhi, Bangalore



**PROJECT :** Marketing Infrastructure Projects, MRPL

**OWNER :** MANGALORE REFINERY AND PETROCHEMICALS LTD

**PMC :** Nauvata Engineering Pvt. Ltd.

**JOB NO. :** JBG20005



Rev. No	Date	Purpose	Prepared by	Checked by	Approved by
1	04-05-2021	RE-ISSUED FOR BID	MLH	KSH	KSH
0	09-03-2021	ISSUED FOR BID	MLH	KSH	KSH
C1	12-12-2020	ISSUED FOR REVIEW/COMMENTS	MLH	KSH	ASN

 <b>MRPL</b>	<b>MRPL Marketing Terminal Project at Devangonhi, Bangalore</b>			 <b>nauvata</b>
	<b>Marketing Infrastructure Projects, MRPL</b>			
	Part – C	<b>DATASHEET FOR</b>	Tender No. :	
Section – C-3	Doc No.:		20005-GEN-M-DS-4026	
Subsection – C-3.41	<b>HSD TANKS</b>	Rev :	1	

### DATA SHEET – HSD (Class B)





### SIZE 24 M. DIA X 20 M. HEIGHT – 8,324 KL (PUMPABLE CAPACITY)

<b>GENERAL</b>	Status: • Tender      ○ Order      ○ As Built						
	Service	HSD (CLASS-B)		Type of Tank	Fixed Cone Roof		
	Location	Devangonhi, Bengaluru		Nominal Diameter	24 m		
	Number of Tanks	3		Overall Height	20 m		
	Equipment Tag Number	FB-A-02A/B/C		Pumpable Capacity m <sup>3</sup>	8,324		
			License capacity m <sup>3</sup>	8,550			
<b>PROCESS</b>	Medium	HSD		Design Liquid Sp. gr.	1.00		
	Specific Gravity	0.820 – 0.880		Design Liquid Level	20.0 m		
	Viscosity Cst	2.54-4.0 @38 °C		Tank Heating / Cooling	Not Required		
	Flash Point °C	32 – 66 °C		Nozzle Heating	Not Required		
	Reid Vapour Pressure Kg/cm <sup>2</sup>	0.02 @38 °C		Heating / Cooling Medium	Nil		
	Corrosivity			Heat load (Kw/hr.)	Nil		
	Filling Rate m <sup>3</sup> /hr.	1,050		Tank Mixers	Required - Jet mixers		
	Emptying Rate m <sup>3</sup> /hr.	1080		Water Draw off Sump	Yes		
	Storage Temp. °C	5 - 45		Tank Gauging	dual gauge		
	Storage Pressure kPa	ATMOSPHERIC		Nitrogen Blanketing	Not Required		
	Design (Vacuum) Pressure MM WC	25		Ambient – Temp °C	40		
	Design (Positive) Pressure MM WC	ATMOSPHERIC + FULL OF LIQUID		Atmos. Press. kPa	100		
	Design Temp. °C	80		Vapour Space mm	5 %		
MDMT Temp. °C	0						
<b>MECHANICAL</b>	Design & Const. Code		API-650 13TH EDITION.		Cathodic Protection	NO	
	Shell Design Method		One Foot Method		Insulation Thickness (mm)	Not Applicable	
	Design Wind Speed (m/sec)		33 (Refer Specification for Tanks - 20005-GEN-M-SPE-4005)			Not Applicable	
	Seismic Code / Zone		As per Specification for Tanks - 20005-GEN-M-SPE-4005 (Outside Seismic Zone)		Finishing & Painting	Shell:	Refer Engineering Design Basis Surface Preparation And Protective Coating
	Foundation Type		Ring Beam Foundation			Roof:	Refer Engineering Design Basis Surface Preparation And Protective Coating
	Corrosion Allowance mm		3.0 mm – 1st Shell course & Bottom Plate, 1.5 mm – Other courses & Roof plate			Bottom:	Refer Engineering Design Basis Surface Preparation And Protective Coating
	Joint Efficiency		0.85		Hydro test:	By Contractor as per Specification for Tanks - 20005-GEN-M-SPE-4005	
					Insulation	Not Applicable	
	Tank Bottom Type		Cone down to Centre		External		
	Hand - Railing		Spiral Stairway & All around the roof		Access	Landing Platform	
					Clean Out Door	YES	
	Tank Roof Type		Fixed Cone		Earthing Boss	3 Nos.	
	Slope	Roof	1 in 12		Lightning protection	NO	
		Bottom	1 in 100		<b>WEIGHT (Note-23)</b>		
	Stiffening Rings		Required As per Code		Empty Weight (MT)	236	
	Inspection & Testing (Refer Specification for Tanks - 20005-GEN-M-SPE-4005)	Hydro Test Level	Upto Full Level		Operating Weight (MT)	7,641.5	
		Radiography	As per API 650		Test Weight (MT)	9,279.2	
Stress Relieving		As per code					
<b>ACCESSORIES (Note-26)</b>	Level Transmitter	Yes		Gauge Hatch	Yes		
	Spiral Stairway	Yes		Name Plate	Yes		
	Hand Railing (On Roof)	Yes		Atmospheric Vent Assembly	Yes		
	Earth Connection	Yes		Foam System	Yes		
	Platform at Roof	Yes		Instrumentation	Yes		
	Foam Pourer Platform	Yes		Level Switch	Yes		
	Water Sprinkler	Yes					
<b>MATERIALS (Note-24)</b>	<b>BOTTOM, SHELL, ROOF &amp; REINFORCEMENT PLATE</b>		A 36 / IS:2062 Gr. B	STAIRWAY PLATFORM AND STRUCTURAL	A 36 / A 53 / IS 2062 Gr. A/B		
	SHELL / ROOF NOZZLE NECK UPTO 250 NB		A 106 Gr. B	HAND RAILING	A 53 / IS 2062 Gr. A/B		
	NOZZLE FLANGES		A 105	GRATINGS	CS GALV.		
	MAN-HOLE NECK / FLANGE / COVER PLATE		A 36 / IS 2062 Gr. B	GAUGE WELL / STILL WELL / SLEEVE	A 106 Gr. B		
	BOLTING FOR NOZZLES		A 193 Gr. B7 / A 194 Gr.2H	FITTINGS	A 234 Gr. WPB		
	BOLTING FOR STRUCTURES		A 193 Gr. B7 / A 194 Gr.2H	NAME PLATE / BRACKET	SS 304 / A 36		
	LEG PIPE SUPT. / SLEEVE		A 106 Gr. B	EARTHING CONN.	AS PER SPECIFICATIONS		
	<b>INTERNALS</b>		A 36 / IS 2062 Gr. B / A 106 Gr. B / SS304	GASKETS (PERMANENT)	SS 316 Spiral Wound Graphite Filled		
	STRUCTURES AND EXTERNALS (GUSSETS)		A 36 / IS 2062 Gr. B	SHELL / ROOF NOZZLE NECK ABOVE 250 NB	A 36		
	ANCHOR BOLTS / NUTS		A 307 Gr. B / A 563 Gr. A / IS 2062 Gr. B	INTERNAL FLOATING ROOF PANEL	Not Applicable 		
	ROOF DRAIN PIPE		A 106 Gr. B	FOAM / COOLING SYSTEM PIPES	As per specification		

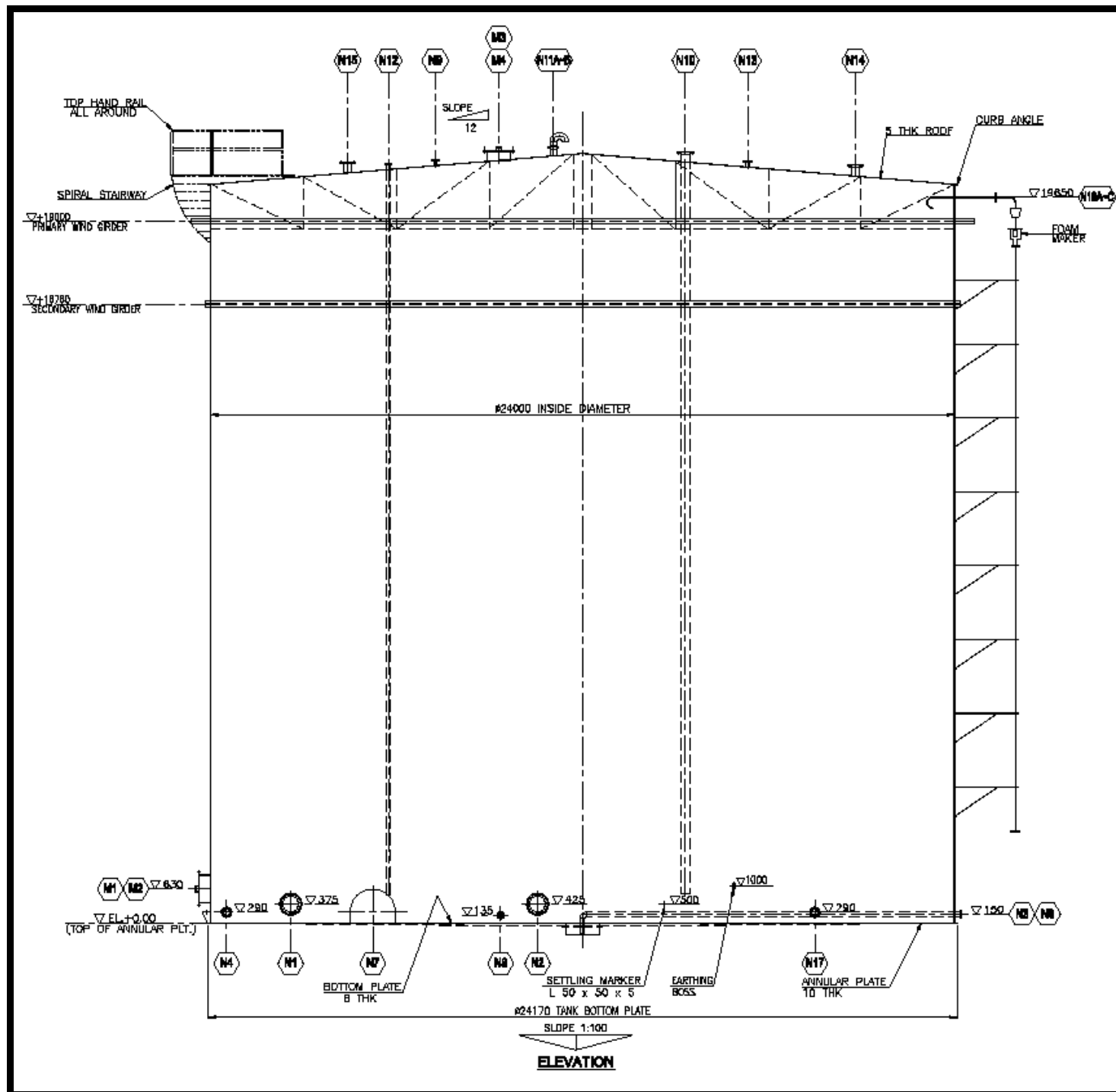
	<b>MRPL Marketing Terminal Project at Devangonhi, Bangalore</b> Marketing Infrastructure Projects, MRPL			
	Part - C	<b>DATASHEET FOR</b>  <b>HSD TANKS</b>		Tender No. : 3200000495
	Section - C-3			Doc No.: 20005-GEN-M-DS-4026
Subsection - C-3.41		Rev : 1		

NOZZLE INDEX							
TAG	SERVICE	QTY.	NOMINALSIZ E (mm)	SCHEDU LE	THIC K (mm)	RATING / TYPE	DESCRIPTION
M1/2	SHELL MANHOLE	2	600	AS PER CODE (8 THK)			WITH COVER
N1	INLET	1	350	SCH	19.0	300/RF	
N2	OUTLET	1	400	SCH 80	21.4	300/RF	
N3	WATER DRAW OFF/DRAIN	1	100	SCH 80	8.5	150/RF	
N4	RECIRCULATION	1	250	SCH 80	10.9	150/RF	WITH JET MIXER
N6	PRODUCT DRAW OFF	1	100	SCH 80	8.5	150/RF	
N7	CLEAN OUT DOOR	1	900 X 1200	-	20	-	
N8	PRESSURE TRANSMITTER	1	50	SCH 160	8.7	300/RF	
N16A-C	FOAM POURER	3	250	SCH 80	15.9	150/RF	WITH DEFLECTOR
N17	OUTLET-2	1	400	SCH 80	21.4	300/RF	
M 3/4	ROOF MANHOLE	2	600	AS PER CODE (6 THK.)			WITH COVER
N9	TEMPERATURE TRANSMITTER	1	75	SCH 40	5.1	300/RF	
N10	LEVEL TRANSMITTER	1	200	SCH 40	8.1	300/RF	RADAR TYPE
N 11A-B	ROOF VENT	2	300	SCH 40	9.2	150/RF	
N12	LEVEL TRANSMITTER	1	200	SCH 40	8.1	300/RF	RADAR TYPE
N13	LEVEL SWITCH	1	80	SCH 80	7.6	300/RF	
N14	DIP HATCH	1	200	SCH 40	8.1	150/RF	WITH COVER
N15	SPARE	1	100	SCH 40	6.2	150/RF	





 	<b>MRPL Marketing Terminal Project at Devangonhi, Bangalore</b> <b>Marketing Infrastructure Projects, MRPL</b>			 	
	Part – C	<b>DATASHEET FOR</b>  <b>HSD TANKS</b>	Tender No. :		3200000495
	Section – C-3		Doc No.:		20005-GEN-M-DS-4026
Subsection – C-3.41	Rev :		1		

### DATA SHEET – HSD STORAGE TANKS

#### NOTES

1. All dimensions are in MM unless otherwise specified.
2. Nozzles above 2" NB shall be provided with reinforcement pads as per API-650. Reinforcing pads shall have tell-tale holes OF ¼" Ø. These pads shall be air tested at 1.05 kg/cm<sup>2</sup> (g), with soap solution & there after filled with hard grease in line with API 650 code.
3. All bolt holes in nozzle flanges & manholes to be straddle center lines of tank & nozzle
4. All tolerances shall be as per of API – 650
5. All F.P weld to be chipped back to sound metal on the second side & rewelded.
6. Three plates joints on bottom shall not be closer than 300 mm from 1) Each other & 2) Tank Shell
7. All erection lugs & cleats to be removed before hydro test.
8. Curb angle joints shall stagger with shell joints at least by 300 mm.
9. Prj. Of nozzle shall be measured from intersection of nozzle axis & outer surface of shell/roof.
10. All weld spatters & large weld beads should be removed by grinding.
11. Flange gasket surfaces shall be 125 AARH finish, refer to project PMS.
12. Calibration & strapping shall be done in accordance with IS 2550 & 2555 or equivalent.
13. Nozzles 2" NB & below shall be provided with 2 stiffener flats of size 40 W \* 8 THK at 90° apart.
14. 300# for inlet and outlet nozzles and 300# for all instrument nozzles.
15. Water to be filled up to curb angle during hydro testing of tank.
16. All sharp corners to be rounded off.
17. Nozzles above 10" NB may be fabricated from plate with 100% radiography for welded seams.
18. Wherever the weld distance on nozzle opening or R.F pad does not comply the requirement of clause no. 5.7.2 same shall be as per fig. 5.9 of API-650.
19. Painting of tank shall be as per Engineering Design Basis Surface Preparation And Protective Coating - 20005-GEN-G-EDB-9122.
20. Testing requirement: (Test requirement mentioned here is indicative only. To be as per Specification of Storage Tank – 20005-GEN-M-SPE-4005 and API 650.)  
 Bottom Plate: By partial vacuum T 3-5 P.S.I.G  
 Shell Weld: Radiography as per API-650 Fig.8.1  
 Nozzle Pad on Shell only: By air pressure at 15 P.S.I.G  
 Shell to Bottom: By kerosene oil & chalk method. As per API-650 Clause no. 7.2.4.3  
 Tank Shell: By filling water up to curb angle  
 Fixed Roof: As per API-650 Clause no. 7.3.7
21. Electrodes:  
 E-6013: Plates up to 12mm thick  
 E-7018: Plates up to 12.5mm thick and above and shell to annular joint
22. Gauge hatch shall be non-sparking type
23. Weight indicated is indicative only. To be confirmed by Contractor during detail engineering.
24. MOC indicated to be verified and confirmed by Contractor during detail engineering.
25. Tanks shall comply with the Project Scope Of Work, Design Basis, Specifications attached else where in the bid. Contractor to indicate the relevant documents during detail engineering.
26. Refer to respective tank GADs for additional accessories.
27. This datasheet shall be read in conjunction with Specification for Tanks – 20005-GEN-M-SPE-4005 and Engineering Design Basis for Static Equipment 20005-GEN-DB-4002.
28. Operating conditions indicated are preliminary and to be verified and updated by contractor during detail engineering.
29. Contractor to submit Inspection Test Plan (ITP) during detail engineering for PMC approval.
30. All Nozzle size indicated in nozzle index are tentative, shall be finalized by LSTK contractor during detail engineering.

	<b>MRPL Marketing Terminal Project at Devangonhi, Bangalore</b> <b>Marketing Infrastructure Projects, MRPL</b>				
	Part – C	<b>DATASHEET FOR</b>  <b>ATF TANKS</b>	Tender No. :		3200000495
	Section – C-3		Doc No.:		20005-GEN-M-DS-4027
Subsection – C-3.42	Rev :		1		

<b>C-3</b>	<b>SPECIFICATIONS AND DATASHEETS</b>
<b>C-3.42</b>	<b>DATASHEET FOR ATF TANKS</b>

## MRPL Marketing Terminal Project at Devangonhi, Bangalore



**PROJECT :** Marketing Infrastructure Projects, MRPL

**OWNER :** MANGALORE REFINERY AND PETROCHEMICALS LTD

**PMC :** Nauvata Engineering Pvt. Ltd.

**JOB NO. :** JBG20005



Rev. No	Date	Purpose	Prepared by	Checked by	Approved by
1	04-05-2021	RE-ISSUED FOR BID	MLH	KSH	KSH
0	09-03-2021	ISSUED FOR BID	MLH	KSH	KSH
C1	12-12-2020	ISSUED FOR REVIEW/COMMENTS	MLH	KSH	ASN

	<b>MRPL Marketing Terminal Project at Devangonhi, Bangalore</b>			
	<b>Marketing Infrastructure Projects, MRPL</b>			
	Part – C	<b>DATASHEET FOR</b>	Tender No. :	
Section – C-3	Doc No.:		20005-GEN-M-DS-4027	
Subsection – C-3.42	<b>ATF TANKS</b>	Rev :	1	

### DATA SHEET – ATF (Class B)

### SIZE 24 M. DIA X 20 M. HEIGHT – 8,144 KL (PUMPABLE CAPACITY)



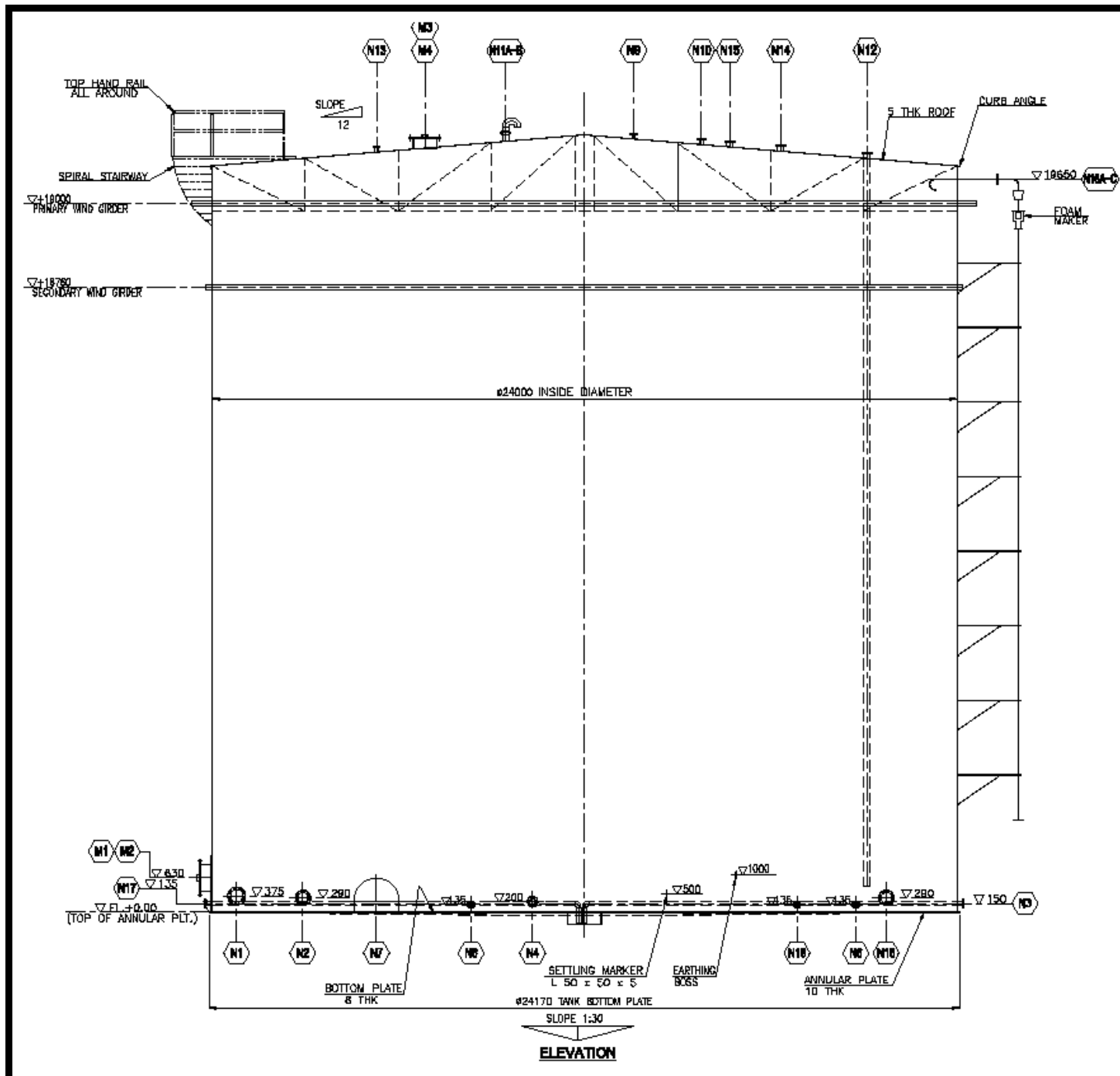

<b>GENERAL</b>	Status: • Tender ○ Order ○ As Built					
	Service (Class B)	Aviation Turbine Fuel	Type of Tank	Fixed Cone Roof		
	Location	Devangonhi, Bengaluru	Nominal Diameter	24.0 m		
	Number of Tanks	3	Overall Height	20.0 m		
	Equipment Tag Number	FB-A-03A/B/C	Pumpable Capacity m <sup>3</sup>	8,144		
		License capacity m <sup>3</sup>	8,300			
<b>PROCESS</b>	Medium	Aviation Turbine Fuel	Design Liquid Sp. gr.	1.00		
	Specific Gravity	0.775-0.840	Design Liquid Level	20.0 m		
	Viscosity Cst	0.8-1.5@38 °C	Tank Heating / Cooling	Not Required		
	Flash Point °C	38	Nozzle Heating	Not Required		
	Reid Vapour Pressure Kg/cm <sup>2</sup>	0.25@38 °C	Heating / Cooling Medium	Nil		
	Corrosivity		Heat load (Kw/hr)	Nil		
	Filling Rate m <sup>3</sup> /hr	1,050	Tank Mixers	Required - Jet mixers		
	Emptying Rate m <sup>3</sup> /hr	360	Water Draw off Sump	Yes		
	Storage Temp. °C	5 - 45	Tank Gauging	Dual Gauges		
	Storage Pressure kPa	ATMOSPHERIC	Nitrogen Blanketing	Not Required		
	Design (Vacuum) Pressure MM WC	25	Ambient – Temp °C	40		
	Design (Positive) Pressure MM WC	ATMOSPHERIC + FULL OF LIQUID	Atmos. Press. kPa	100		
	Design Temp. °C	80	Vapour Space mm	5%		
MDMT Temp. °C	0					
<b>MECHANICAL</b>	Design & Const. Code	API-650 13TH EDITION.		Cathodic Protection	NO	
	Shell Design Method	One Foot Method		Insulation Thickness (mm)	Not Applicable	
	Design Wind Speed (m/sec)	33 (Refer Specification for Tanks - 20005-GEN-M-SPE-4005)			Not Applicable	
	Seismic Code / Zone	As per Specification for Tanks - 20005-GEN-M-SPE-4005 (Outside Seismic Zone)		Finishing & Painting	Shell:	Refer Engineering Design Basis Surface Preparation And Protective Coating
	Foundation Type	Ring Beam Foundation			Roof:	Refer Engineering Design Basis Surface Preparation And Protective Coating
	Corrosion Allowance mm	3.0 mm – 1st Shell course & Bottom Plate, 1.5 mm – Other courses & Roof plate			Bottom:	Refer Engineering Design Basis Surface Preparation And Protective Coating
	Joint Efficiency	0.85		Hydro test:	By Contractor as per Specification for Tanks - 20005-GEN-M-SPE-4005	
				Insulation	Not Applicable	
	Tank Bottom Type	Cone down to Centre		External		
	Hand – Railing	Spiral Stairway & All around the roof		Access	Landing Platform	
				Clean Out Door	YES	
	Tank Roof Type	Fixed Cone		Earthing Boss	3 Nos.	
	Slope	Roof	1 in 12	1 in 12		
		Bottom	1 in 30	<b>WEIGHT (Note-23)</b>		
	Stiffening Rings	Required As per Code		Empty Weight (MT)	236	
	Inspection & Testing (Refer Specification for Tanks - 20005-GEN-M-SPE-4005)	Hydro Test Level	Upto Full Level		Operating Weight (MT)	7,324.9
		Radiography	As per API 650		Test Weight (MT)	9279.2
Stress Relieving		As per code				
<b>ACCESSORIES (Note-26)</b>	Level Transmitter	Yes		Gauge Hatch	Yes	
	Spiral Stairway	Yes		Name Plate	Yes	
	Hand Railing (On Roof)	Yes		Atmospheric Vent Assembly	Yes	
	Earth Connection	Yes		Foam System	Yes	
	Platform at Roof	Yes		Instrumentation	Yes	
	Foam Poured Platform	Yes		<b>Floating Suction</b>	<b>Yes</b>	
	Water Sprinkler	Yes		Level Switch	Yes	
<b>MATERIALS (Note-24)</b>	<b>BOTTOM, SHELL, ROOF &amp; REINFORCEMENT PLATE</b>	A 36 / IS:2062 Gr. B	STAIRWAY PLATFORM AND STRUCTURAL	A 36 / A 53 / IS 2062 Gr. A/B		
	SHELL / ROOF NOZZLE NECK UPTO 250 NB	A 106 Gr. B	HAND RAILING	A 53 / IS 2062 Gr. A/B		
	NOZZLE FLANGES	A 105	GRATINGS	CS GALV.		
	MAN-HOLE NECK / FLANGE / COVER PLATE	A 36 / IS 2062 Gr. B	GAUGE WELL / STILL WELL / SLEEVE	A 106 Gr. B		
	BOLTING FOR NOZZLES	A 193 Gr. B7 / A 194 Gr.2H	FITTINGS	A 234 Gr. WPB		
	BOLTING FOR STRUCTURES	A 193 Gr. B7 / A 194 Gr.2H	NAME PLATE / BRACKET	SS 304 / A 36		
	LEG PIPE SUPT. / SLEEVE	A 106 Gr. B	EARTHING CONN.	AS PER SPECIFICATIONS		
	<b>INTERNALS</b>	A 36 / IS 2062 Gr. B / A 106 Gr. B / SS304	GASKETS (PERMANENT)	SS 316 Spiral Wound Graphite Filled		
	STRUCTURES AND EXTERNALS (GUSSETS)	A 36 / IS 2062 Gr. B	SHELL / ROOF NOZZLE NECK ABOVE 250 NB	A 36		
	ANCHOR BOLTS / NUTS	A 307 Gr. B / A 563 Gr. A / IS 2062 Gr. B	INTERNAL FLOATING ROOF PANEL	Not Applicable <span style="float: right;">1</span>		
	ROOF DRAIN PIPE	A 106 Gr. B	FOAM / COOLING SYSTEM PIPES	As per specification		

	<b>MRPL Marketing Terminal Project at Devangonhi, Bangalore</b> Marketing Infrastructure Projects, MRPL			
	Part - C	<b>DATASHEET FOR</b>  <b>ATF TANKS</b>		Tender No. : 3200000495
	Section - C-3			Doc No.: 20005-GEN-M-DS-4027
Subsection - C-3.42		Rev : 1		

NOZZLE INDEX							
TAG	SERVICE	QTY.	NOMINAL SIZE (mm)	SCHEDULE	THICKNESS (mm)	RATING / TYPE	DESCRIPTION
M1/2	SHELL MANHOLE	2	600	AS PER CODE (8 THK)			WITH COVER
N1	INLET	1	350	SCH	19.0	300/RF	
N2	OUTLET	1	250	SCH 80	15.0	300/RF	WITH FLOATING SUCTION
N3	WATER DRAW OFF/DRAIN	1	100	SCH 80	8.5	150/RF	
N4	RECIRCULATION	1	150	SCH 80	10.9	150/RF	WITH JET MIXER
N6	FAST FLUSHER	1	50	SCH 160	8.7	150/RF	
N7	CLEAN OUT DOOR	1	900 X 1200	-	20	-	
N8	PRESSURE TRANSMITTER	1	50	SCH 160	8.7	300/RF	
N16A-C	FOAM POURER	3	250	SCH 80	15.9	150/RF	WITH DEFLECTOR
N17	PRODUCT DRAW OFF	1	100	SCH 80	8.5	150/RF	
N18	OUTLET-2	1	250	SCH 80	15.9	300/RF	
M 3/4	ROOF MANHOLE	2	600	AS PER CODE (6 THK.)			WITH COVER
N9	TEMPERATURE TRANSMITTER	1	75	SCH 40	5.1	300/RF	
N10	LEVEL TRANSMITTER	1	200	SCH 40	8.1	300/RF	RADAR TYPE
N 11A-B	ROOF VENT	2	250	SCH 40	8.1	150/RF	
N12	LEVEL TRANSMITTER	1	200	SCH 40	8.1	300/RF	RADAR TYPE
N13	LEVEL SWITCH	1	80	SCH 80	7.6	300/RF	
N14	DIP HATCH	1	200	SCH 40	8.1	150/RF	WITH COVER
N15	SPARE	1	100	SCH 40	6.2	150/RF	







 	<b>MRPL Marketing Terminal Project at Devangonhi, Bangalore</b> <b>Marketing Infrastructure Projects, MRPL</b>			 
	Part – C	<b>DATASHEET FOR</b>  <b>ATF TANKS</b>	Tender No. : 3200000495	
	Section – C-3		Doc No.: 20005-GEN-M-DS-4027	
Subsection – C-3.42	Rev : 1			

### DATA SHEET – ATF STORAGE TANKS

#### NOTES

1. All dimensions are in MM unless otherwise specified.
2. Nozzles above 2" NB shall be provided with reinforcement pads as per API-650. Reinforcing pads shall have tell-tale holes OF ¼" Ø. These pads shall be air tested at 1.05 kg/cm<sup>2</sup> (g), with soap solution & there after filled with hard grease in line with API 650 code.
3. All bolt holes in nozzle flanges & manholes to be straddle center lines of tank & nozzle
4. All tolerances shall be as per API – 650
5. All F.P weld to be chipped back to sound metal on the second side & rewelded.
6. Three plates joints on bottom shall not be closer than 300 mm from 1) Each other & 2) Tank Shell
7. All erection lugs & cleats to be removed before hydro test.
8. Curb angle joints shall stagger with shell joints at least by 300 mm.
9. Prj. Of nozzle shall be measured from intersection of nozzle axis & outer surface of shell/roof.
10. All weld spatters & large weld beads should be removed by grinding.
11. Flange gasket surfaces shall be 125 AARH finish, refer to project PMS.
12. Calibration & strapping shall be done in accordance with IS 2550 & 2555 or equivalent.
13. Nozzles 2" NB & below shall be provided with 2 stiffener flats of size 40 W \* 8 THK at 90° apart.
14. 300# for inlet and outlet nozzles and 300# for all instrument nozzles.
15. Water to be filled up to curb angle during hydro testing of tank.
16. All sharp corners to be rounded off.
17. Nozzles above 10" NB may be fabricated from plate with 100% radiography for welded seams.
18. Wherever the weld distance on nozzle opening or R.F pad does not comply the requirement of clause no. 5.7.2 same shall be as per fig. 5.9 of API-650.
19. Painting of tank shall be as per Engineering Design Basis Surface Preparation And Protective Coating - 20005-GEN-G-EDB-9122.
20. Testing requirement: (Test requirement mentioned here is indicative only. To be as per Specification of Storage Tank – 20005-GEN-M-SPE-4005 and API 650.)
 

Bottom Plate:	By partial vacuum T 3-5 P.S.I.G
Shell Weld:	Radiography as per API-650 Fig.8.1
Nozzle Pad on Shell only:	By air pressure at 15 P.S.I.G
Shell to Bottom:	By kerosene oil & chalk method. As per API-650 Clause no. 7.2.4.3
Tank Shell:	By filling water up to curb angle
21. Fixed Roof: As per API-650 Clause no. 7.3.7
- Electrodes: E-6013: Plates up to 12mm thick  
E-7018: Plates up to 12.5mm thick and above and shell to annular joint
22. Gauge hatch shall be non-sparking type.
23. Weight indicated is indicative only. To be confirmed by Contractor during detail engineering.
24. MOC indicated to be verified and confirmed by Contractor during detail engineering.
25. Tanks shall comply with the Project Scope Of Work, Design Basis, Specifications attached else where in the bid. Contractor to indicate the relevant documents during detail engineering.
26. Refer to respective tank GADs for additional accessories.
27. This datasheet shall be read in conjunction with Specification of Tanks – 20005-GEN-M-SPE-4005 and Engineering Design Basis for Static Equipment 20005-GEN-DB-4002.
28. Operating conditions indicated are preliminary and to be verified and updated by contractor during detail engineering.
29. Contractor to submit inspection test plan (ITP) during detail engineering for PMC approval.
30. All Nozzle size indicated in nozzle index are tentative, shall be finalized by LSTK contractor during detail engineering.

	<b>MRPL Marketing Terminal Project at Devangonhi, Bangalore</b> <b>Marketing Infrastructure Projects, MRPL</b>				
	Part – C	<b>DATASHEET FOR</b>  <b>BIO-DIESEL TANK</b>	Tender No. :		3200000495
	Section – C-3		Doc No.:		20005-GEN-M-DS-4028
Subsection – C-3.43	Rev :		1		

<b>C-3</b>	<b>SPECIFICATIONS AND DATASHEETS</b>
<b>C-3.43</b>	<b>DATASHEET FOR BIO-DIESEL TANK</b>

## MRPL Marketing Terminal Project at Devangonhi, Bangalore





**PROJECT :** Marketing Infrastructure Projects, MRPL

**OWNER :** MANGALORE REFINERY AND PETROCHEMICALS LTD

**PMC :** Nauvata Engineering Pvt. Ltd.



**JOB NO. :** JBG20005

Rev. No	Date	Purpose	Prepared by	Checked by	Approved by
1	04-05-2021	RE-ISSUED FOR BID	MLH	KSH	KSH
0	09-03-2021	ISSUED FOR BID	MLH	KSH	KSH
C1	12-12-2020	ISSUED FOR REVIEW/COMMENTS	MLH	KSH	ASN

 	<b>MRPL Marketing Terminal Project at Devangonhi, Bangalore</b>			 
	<b>Marketing Infrastructure Projects, MRPL</b>			
	Part – C	<b>DATASHEET FOR</b>	Tender No. :	
Section – C-3	Doc No.:		20005-GEN-M-DS-4028	
Subsection – C-3.43	<b>BIO-DIESEL TANK</b>	Rev :	1	





**DATA SHEET (BIO-DIESEL) (Class B)**  
**SIZE 9 M. DIA X 9 M. HEIGHT – 514 KL (PUMPABLE CAPACITY)**

<b>GENERAL</b>	Status: • Tender      ○ Order      ○ As Built					
	Service	Bio-Diesel	Type of Tank	Fixed Cone Roof		
	Location	Devangonhi, Bengaluru	Nominal Diameter	9 m		
	Number of Tanks	2	Overall Height	9 m		
	Equipment Tag Number	FB-A-04A/B	Pumpable Capacity m <sup>3</sup>	514		
		License capacity m <sup>3</sup>	550			
<b>PROCESS</b>	Medium	Bio-Diesel	Design Liquid Sp. gr.	1.00		
	Specific Gravity	0.820 – 0.880	Design Liquid Level	9.0 m		
	Viscosity Cst	3.5-6.0 @ 38 °C	Tank Heating / Cooling	Not Required		
	Flash Point °C	55 – 66 °C	Nozzle Heating	Not Required		
	Reid Vapour Pressure Kg/cm <sup>2</sup>	0.02 @38 °C	Heating / Cooling Medium	Nil		
	Corrosivity		Heat load (Kw/hr.)	Nil		
	Filling Rate m <sup>3</sup> /hr.	30	Tank Mixers	Not Required		
	Emptying Rate m <sup>3</sup> /hr.	30	Water Draw off Sump	Yes		
	Storage Temp. °C	5 - 45	Tank Gauging	Dual gauge		
	Storage Pressure kPa	ATMOSPHERIC	Nitrogen Blanketing	Not Required		
	Design (Vacuum) Pressure MM WC	25	Ambient – Temp °C	40		
	Design (Positive) Pressure MM WC	ATMOSPHERIC + FULL OF LIQUID	Atmos. Press. kPa	100		
	Design Temp. °C	80	Vapour Space mm	5 %		
MDMT Temp. °C	0	Vapour Space mm	5 %			
<b>MECHANICAL</b>	Design & Const. Code	API-650 13TH EDITION.		Cathodic Protection	NO	
	Shell Design Method	One Foot Method		Insulation Thickness (mm)	Not Applicable	
	Design Wind Speed (m/sec)	33 (Refer Specification for Tanks - 20005-GEN-M-SPE-4005)			Not Applicable	
	Seismic Code / Zone	As per Specification for Tanks - 20005-GEN-M-SPE-4005 (Outside Seismic Zone)		Finishing & Painting	Shell:	Refer Engineering Design Basis Surface Preparation And Protective Coating
	Foundation Type	Ring Beam Foundation			Roof:	Refer Engineering Design Basis Surface Preparation And Protective Coating
	Corrosion Allowance mm	3.0 mm – 1st Shell course & Bottom Plate, 1.5 mm – Other courses & Roof plate			Bottom:	Refer Engineering Design Basis Surface Preparation And Protective Coating
	Joint Efficiency	0.85		Hydro test:	By Contractor as per Specification for Tanks - 20005-GEN-M-SPE-4005	
				Insulation	Not Applicable	
	Tank Bottom Type	Cone down to Centre		External		
	Hand - Railing	Spiral Stairway & All around the roof		Access	Landing Platform	
				Clean Out Door	YES	
	Tank Roof Type	Fixed Cone		Earthing Boss	2 Nos.	
	Slope	Roof	1 in 12		Lightning protection	NO
		Bottom	1 in 100		<b>WEIGHT (Note-23)</b>	
	Stiffening Rings	Required As per Code		Empty Weight (MT)	25	
Inspection & Testing (Refer Specification for Tanks - 20005-GEN-M-SPE-4005)	Hydro Test Level	Upto Full Level		Operating Weight (MT)	483.5	
	Radiography	As per API 650		Test Weight (MT)	572.2	
	Stress Relieving	As per code				
<b>ACCESSORIES (Note-26)</b>	Level Transmitter	Yes		Gauge Hatch	Yes	
	Spiral Stairway	Yes		Name Plate	Yes	
	Hand Railing (On Roof)	Yes		Atmospheric Vent Assembly	Yes	
	Earth Connection	Yes		Foam System	Yes	
	Platform at Roof	Yes		Instrumentation	Yes	
	Foam Pourer Platform	NO		Level Switch	Yes	
	Water Sprinkler	Yes				
<b>MATERIALS (Note-24)</b>	<b>BOTTOM, SHELL, ROOF &amp; REINFORCEMENT PLATE</b>	A 36 / IS:2062 Gr. B		STAIRWAY PLATFORM AND STRUCTURAL	A 36 / A 53 / IS 2062 Gr. A/B	
	SHELL / ROOF NOZZLE NECK UPTO 250 NB	A 106 Gr. B		HAND RAILING	A 53 / IS 2062 Gr. A/B	
	NOZZLE FLANGES	A 105		GRATINGS	CS GALV.	
	MAN-HOLE NECK / FLANGE / COVER PLATE	A 36 / IS 2062 Gr. B		GAUGE WELL / STILL WELL / SLEEVE	A 106 Gr. B	
	BOLTING FOR NOZZLES	A 193 Gr. B7 / A 194 Gr.2H		FITTINGS	A 234 Gr. WPB	
	BOLTING FOR STRUCTURES	A 193 Gr. B7 / A 194 Gr.2H		NAME PLATE / BRACKET	SS 304 / A 36	
	LEG PIPE SUPT. / SLEEVE	A 106 Gr. B		EARTHING CONN.	AS PER SPECIFICATIONS	
	<b>INTERNALS</b>	A 36 / IS 2062 Gr. B / A 106 Gr. B / SS304		GASKETS (PERMANENT)	SS 316 Spiral Wound Graphite Filled	
	STRUCTURES AND EXTERNALS (GUSSETS)	A 36 / IS 2062 Gr. B		SHELL / ROOF NOZZLE NECK ABOVE 250 NB	A 36	
	ANCHOR BOLTS / NUTS	A 307 Gr. B / A 563 Gr. A / IS 2062 Gr. B		INTERNAL FLOATING ROOF PANEL	Not Applicable <b>1</b>	
	ROOF DRAIN PIPE	A 106 Gr. B		FOAM / COOLING SYSTEM PIPES	As per specification	

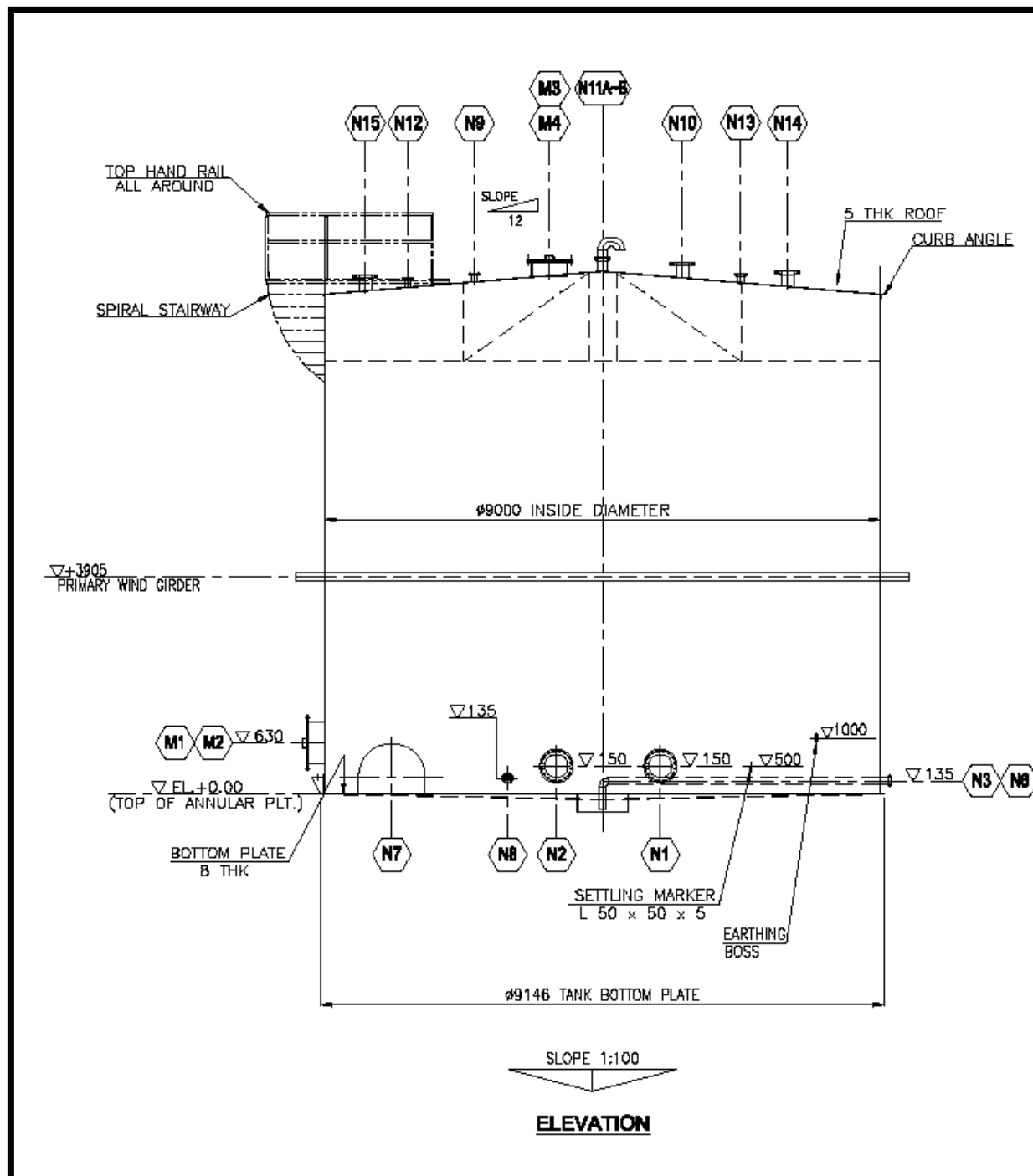
	<b>MRPL Marketing Terminal Project at Devangonhi, Bangalore</b>		
	Marketing Infrastructure Projects, MRPL		
	Part - C	<b>DATASHEET FOR</b>	
Section - C-3	<b>BIO-DIESEL TANK</b>	Doc No.: 20005-GEN-M-DS-4028	
Subsection - C-3.43		Rev : 1	

NOZZLE INDEX							
TAG	SERVICE	QTY.	NOMINALSIZ E (mm)	SCHUD LE	THIC K (mm)	RATING / TYPE	DESCRIPTION
M1/2	SHELL MANHOLE	2	600	AS PER CODE (8 THK)			WITH COVER
N1	INLET	1	100	SCH 80	8.5	300/RF	
N2	OUTLET	1	100	SCH 80	8.5	300/RF	
N3	WATER DRAW OFF/DRAIN	1	80	SCH 80	7.6	150/RF	
N6	PRODUCT DRAW OFF	1	80	SCH 80	7.6	150/RF	
N7	CLEAN OUT DOOR	1	900 X 1200	-	8	-	
N8	PRESSURE TRANSMITTER	1	50	SCH 160	8.7	300/RF	
M 3/4	ROOF MANHOLE	2	600	AS PER CODE (6 THK.)			WITH COVER
N9	TEMPERATURE TRANSMITTER	1	75	SCH 40	5.1	300/RF	
N10	LEVEL TRANSMITTER	1	200	SCH 40	8.1	300/RF	RADAR TYPE
N 11A-B	ROOF VENT	2	150	SCH 40	7.6	150/RF	
N12	LEVEL TRANSMITTER	1	200	SCH 40	8.1	300/RF	RADAR TYPE
N13	LEVEL SWITCH	1	80	SCH 80	7.6	300/RF	
N14	DIP HATCH	1	200	SCH 40	8.1	150/RF	WITH COVER
N15	SPARE	1	100	SCH 40	6.2	150/RF	





 	<b>MRPL Marketing Terminal Project at Devangonhi, Bangalore</b>			 
	<b>Marketing Infrastructure Projects, MRPL</b>			
	Part – C	<b>DATASHEET FOR</b>	Tender No. :	
Section – C-3	Doc No.:		20005-GEN-M-DS-4028	
Subsection – C-3.43	<b>BIO-DIESEL TANK</b>	Rev :	1	

## DATA SHEET – BIO-DIESEL STORAGE TANKS

### NOTES

1. All dimensions are in MM unless otherwise specified.
2. Nozzles above 2" NB shall be provided with reinforcement pads as per API-650. Reinforcing pads shall have tell-tale holes OF ¼" Ø. These pads shall be air tested at 1.05 kg/cm<sup>2</sup> (g), with soap solution & there after filled with hard grease in line with API 650 code.
3. All bolt holes in nozzle flanges & manholes to be straddle center lines of tank & nozzle
4. All tolerances shall be as per clause 7.5 of API – 650
5. All F.P weld to be chipped back to sound metal on the second side & rewelded.
6. Three plates joints on bottom shall not be closer than 300 mm from 1) Each other & 2) Tank Shell
7. All erection lugs & cleats to be removed before hydro test.
8. Curb angle joints shall stagger with shell joints at least by 300 mm.
9. Prj. Of nozzle shall be measured from intersection of nozzle axis & outer surface of shell/roof.
10. All weld spatters & large weld beads should be removed by grinding.
11. Flange gasket surfaces shall be 125 AARH finish, refer to project PMS.
12. Calibration & strapping shall be done in accordance with IS 2550 & 2555 or equivalent.
13. Nozzles 2" NB & below shall be provided with 2 stiffener flats of size 40 W \* 8 THK at 90° apart.
14. 300# for inlet and outlet nozzles and 300# for all instrument nozzles.
15. Water to be filled up to curb angle during hydro testing of tank.
16. All sharp corners to be rounded off.
17. Nozzles above 10" NB may be fabricated from plate with 100% radiography for welded seams.
18. Wherever the weld distance on nozzle opening or R.F pad does not comply the requirement of clause no. 5.7.2 same shall be as per fig. 5.9 of API-650.
19. Painting of tank shall be as per Engineering Design Basis Surface Preparation And Protective Coating - 20005-GEN-G-EDB-9122.
20. Testing requirement: (Test requirement mentioned here is indicative only. To be as per Specification of Storage Tank – 20005-GEN-M-SPE-4005 and API 650.)
 

Bottom Plate:	By partial vacuum T 3-5 P.S.I.G
Shell Weld:	Radiography as per API-650 Fig.8.1
Nozzle Pad on Shell only:	By air pressure at 15 P.S.I.G
Shell to Bottom:	By kerosene oil & chalk method. As per API-650 Clause no. 7.2.4.3
Tank Shell:	By filling water up to curb angle
21. Fixed Roof: As per API-650 Clause no. 7.3.7
- Electrodes: E-6013: Plates up to 12mm thick  
E-7018: Plates up to 12.5mm thick and above and shell to annular joint
22. Gauge hatch shall be non-sparking type.
23. Weight indicated is indicative only. To be confirmed by Contractor during detail engineering.
24. MOC indicated to be verified and confirmed by Contractor during detail engineering.
25. Tanks shall comply with the Project Scope Of Work, Design Basis, Specifications attached else where in the bid. Contractor to indicate the relevant documents during detail engineering.
26. Refer to respective tank GADs for additional accessories.
27. This datasheet shall be read in conjunction with Specification of Tanks – 20005-GEN-M-SPE-4005 and Engineering Design Basis for Static Equipment 20005-GEN-DB-4002.
28. Operating conditions indicated are preliminary and to be verified and updated by contractor during detail engineering.
29. Contractor to inspection test plan (ITP) during detail engineering for PMC approval.
30. All Nozzle size indicated in nozzle index are tentative, shall be finalized by LSTK contractor during detail engineering.

	<b>MRPL Marketing Terminal Project at Devangonhi, Bangalore</b> <b>Marketing Infrastructure Projects, MRPL</b>				
	Part – C	<b>DATASHEET FOR</b> <b>INTER-PHASE TANK</b>	Tender No. :		3200000495
	Section – C-3		Doc No.:		20005-GEN-M-DS-4029
Subsection – C-3.44	Rev :		1		

<b>C-3</b>	<b>SPECIFICATIONS AND DATASHEETS</b>
<b>C-3.44</b>	<b>DATASHEET FOR INTER-PHASE TANK</b>

## MRPL Marketing Terminal Project at Devangonhi, Bangalore





**PROJECT :** Marketing Infrastructure Projects, MRPL

**OWNER :** MANGALORE REFINERY AND PETROCHEMICALS LTD

**PMC :** Nauvata Engineering Pvt. Ltd.



**JOB NO. :** JBG20005

Rev. No	Date	Purpose	Prepared by	Checked by	Approved by
1	04-05-2021	RE-ISSUED FOR BID	MLH	KSH	KSH
0	09-03-2021	ISSUED FOR BID	MLH	KSH	KSH
C1	12-12-2020	ISSUED FOR REVIEW/COMMENTS	MLH	KSH	ASN

 	<b>MRPL Marketing Terminal Project at Devangonhi, Bangalore</b> Marketing Infrastructure Projects, MRPL			 	
	Part – C	<b>DATASHEET FOR</b> <b>INTER-PHASE TANK</b>	Tender No. :		3200000495
	Section – C-3		Doc No.:		20005-GEN-M-DS-4029
Subsection – C-3.44	Rev :		1		

**DATA SHEET (INTER-PHASE) (CLASS B)**  
**SIZE 10 M. DIA X 15 M. HEIGHT – 1,053 KL (PUMPABLE CAPACITY)**



<b>GENERAL</b>	Status: • Tender ○ Order ○ As Built					
	Service	Inter-phase		Type of Tank	Fixed Cone Roof	
	Location	Devangonhi, Bengaluru		Nominal Diameter	10 m	
	Number of Tanks	1		Overall Height	15 m	
	Equipment Tag Number	FB-A-05A		Pumpable Capacity m <sup>3</sup>	1,053	
			License capacity m <sup>3</sup>	1,100		
<b>PROCESS</b>	Medium	Inter-phase		Design Liquid Sp. gr.	1.00	
	Specific Gravity	0.820 – 0.880		Design Liquid Level	15.0 m	
	Viscosity Cst	1.5-5.9 @38 °		Tank Heating / Cooling	Not Required	
	Flash Point °C	32 – 66 °C		Nozzle Heating	Not Required	
	Reid Vapour Pressure Kg/cm <sup>2</sup>	0.02 @38 °C		Heating / Cooling Medium	Nil	
	Corrosivity			Heat load (Kw/hr.)	Nil	
	Filling Rate m <sup>3</sup> /hr.	1,050		Tank Mixers	Not Required	
	Emptying Rate m <sup>3</sup> /hr.	60		Water Draw off Sump	Yes	
	Storage Temp. °C	5 - 45		Tank Gauging	Dual gauge	
	Storage Pressure kPa	ATMOSPHERIC		Nitrogen Blanketing	Not Required	
	Design (Vacuum) Pressure MM WC	25		Ambient – Temp °C	40	
	Design (Positive) Pressure MM WC	ATMOSPHERIC + FULL OF LIQUID		Atmos. Press. kPa	100	
	Design Temp. °C	80		Vapour Space mm	5 %	
MDMT Temp. °C	0					
<b>MECHANICAL</b>	Design & Const. Code	API-650 13TH EDITION.		Cathodic Protection	NO	
	Shell Design Method	One Foot Method		Insulation Thickness (mm)	Not Applicable	
	Design Wind Speed (m/sec)	33 (Refer Specification for Tanks - 20005-GEN-M-SPE-4005)			Not Applicable	
	Seismic Code / Zone	As per Specification for Tanks - 20005-GEN-M-SPE-4005 (Outside Seismic Zone)		Finishing & Painting	Shell:	Refer Engineering Design Basis Surface Preparation And Protective Coating
	Foundation Type	Ring Beam Foundation			Roof:	Refer Engineering Design Basis Surface Preparation And Protective Coating
	Corrosion Allowance mm	3.0 mm – 1st Shell course & Bottom Plate, 1.5 mm – Other courses & Roof plate			Bottom:	Refer Engineering Design Basis Surface Preparation And Protective Coating
	Joint Efficiency	0.85		Hydro test:	By Contractor as per Specification for Tanks - 20005-GEN-M-SPE-4005	
				Insulation	Not Applicable	
	Tank Bottom Type	Cone down to Centre		External		
	Hand - Railing	Spiral Stairway & All around the roof		Access	Landing Platform	
				Clean Out Door	YES	
	Tank Roof Type	Fixed Cone		Earthing Boss	1 Nos.	
	Slope	Roof	1 in 12		Lightning protection	NO
		Bottom	1 in 100		<b>WEIGHT (Note-23)</b>	
	Stiffening Rings	Required As per Code		Empty Weight (MT)	40	
	Inspection & Testing (Refer Specification for Tanks - 20005-GEN-M-SPE-4005)	Hydro Test Level	Upto Full Level		Operating Weight (MT)	994.9
		Radiography	As per API 650		Test Weight (MT)	1177.5
Stress Relieving		As per code				
<b>ACCESSORIES (Note-26)</b>	Level Transmitter	Yes		Gauge Hatch	Yes	
	Spiral Stairway	Yes		Name Plate	Yes	
	Hand Railing (On Roof)	Yes		Atmospheric Vent Assembly	Yes	
	Earth Connection	Yes		Foam System	Yes	
	Platform at Roof	Yes		Instrumentation	Yes	
	Foam Pourer Platform	NO		Level Switch	Yes	
	Water Sprinkler	Yes				
<b>MATERIALS (Note-24)</b>	<b>BOTTOM, SHELL, ROOF &amp; REINFORCEMENT PLATE</b>	A 36 / IS:2062 Gr. B		STAIRWAY PLATFORM AND STRUCTURAL	A 36 / A 53 / IS 2062 Gr. A/B	
	SHELL / ROOF NOZZLE NECK UPTO 250 NB	A 106 Gr. B		HAND RAILING	A 53 / IS 2062 Gr. A/B	
	NOZZLE FLANGES	A 105		GRATINGS	CS GALV.	
	MAN-HOLE NECK / FLANGE / COVER PLATE	A 36 / IS 2062 Gr. B		GAUGE WELL / STILL WELL / SLEEVE	A 106 Gr. B	
	BOLTING FOR NOZZLES	A 193 Gr. B7 / A 194 Gr.2H		FITTINGS	A 234 Gr. WPB	
	BOLTING FOR STRUCTURES	A 193 Gr. B7 / A 194 Gr.2H		NAME PLATE / BRACKET	SS 304 / A 36	
	LEG PIPE SUPT. / SLEEVE	A 106 Gr. B		EARTHING CONN.	AS PER SPECIFICATIONS	
	<b>INTERNALS</b>	A 36 / IS 2062 Gr. B / A 106 Gr. B / SS304		GASKETS (PERMANENT)	SS 316 Spiral Wound Graphite Filled	
	STRUCTURES AND EXTERNALS (GUSSETS)	A 36 / IS 2062 Gr. B		SHELL / ROOF NOZZLE NECK ABOVE 250 NB	A 36	
	ANCHOR BOLTS / NUTS	A 307 Gr. B / A 563 Gr. A / IS 2062 Gr. B		INTERNAL FLOATING ROOF PANEL	Not Applicable <span style="float: right;">1</span>	
	ROOF DRAIN PIPE	A 106 Gr. B		FOAM / COOLING SYSTEM PIPES	As per specification	

 	<b>MRPL Marketing Terminal Project at Devangonhi, Bangalore</b> Marketing Infrastructure Projects, MRPL		 nauvata <small>ENGINEERING CONSULTANTS</small>			
	Part - C	<b>DATASHEET FOR</b>  <b>INTER-PHASE TANK</b>			Tender No. :	3200000495
	Section - C-3				Doc No.:	20005-GEN-M-DS-4029
Subsection - C-3.44	Rev :		1			

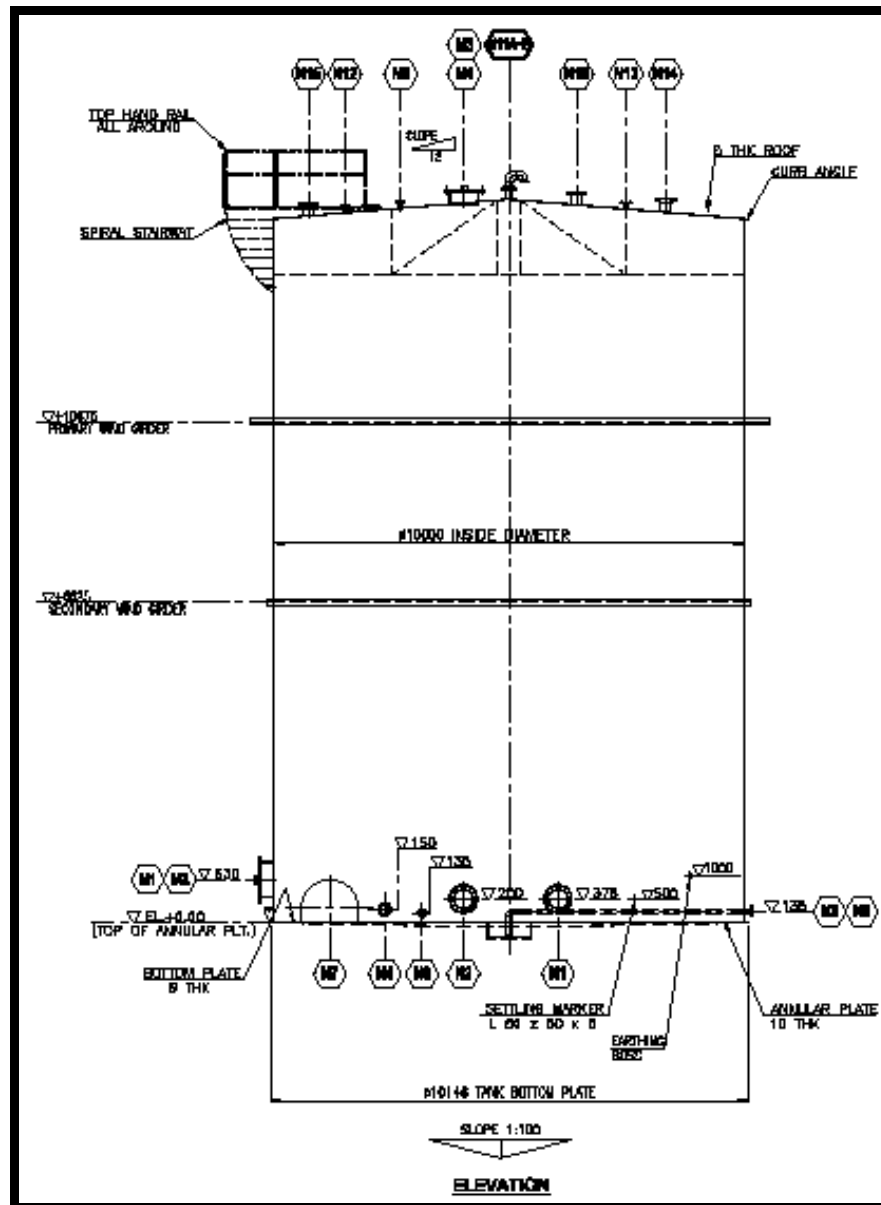
NOZZLE INDEX							
TAG	SERVICE	QTY.	NOMINALSIZ E (mm)	SCHEDU LE	THIC K (mm)	RATING / TYPE	DESCRIPTION
M1/2	SHELL MANHOLE	2	600	AS PER CODE (8 THK)			WITH COVER
N1	INLET	1	350	SCH 80	17.4	300/RF	
N2	OUTLET	1	150	SCH 80	10.9	300/RF	
N3	WATER DRAW OFF/DRAIN	1	80	SCH 80	7.62	150/RF	
N4	SPARE	1	100	SCH 80	8.56	150/RF	
N6	PRODUCT DRAW OFF	1	80	SCH 80	7.62	150/RF	
N7	CLEAN OUT DOOR	1	900 X 1200	-	8	-	
N8	PRESSURE TRANSMITTER	1	50	SCH 160	8.7	300/RF	
M 3/4	ROOF MANHOLE	2	600	AS PER CODE (6 THK.)			WITH DEFLECTOR
N9	TEMPERATURE TRANSMITTER	1	75	SCH 40	5.1	300/RF	
N10	LEVEL TRANSMITTER	1	200	SCH 40	8.1	300/RF	RADAR TYPE
N 11A-B	ROOF VENT	2	150	SCH 40	8.1	150/RF	
N12	LEVEL TRANSMITTER	1	200	SCH 40	8.1	300/RF	RADAR TYPE
N13	LEVEL SWITCH	1	80	SCH 80	7.6	300/RF	
N14	DIP HATCH	1	200	SCH 40	8.1	150/RF	WITH COVER
N15	SPARE	1	100	SCH 40	6.2	150/RF	







 	<b>MRPL Marketing Terminal Project at Devangonhi, Bangalore</b> Marketing Infrastructure Projects, MRPL				
	Part – C	<b>DATASHEET FOR</b> <b>INTER-PHASE TANK</b>	Tender No. :		3200000495
	Section – C-3		Doc No.:		20005-GEN-M-DS-4029
Subsection – C-3.44	Rev :		1		

## DATA SHEET – INTER-PHASE STORAGE TANKS

### NOTES

1. All dimensions are in MM unless otherwise specified.
2. Nozzles above 2" NB shall be provided with reinforcement pads as per API-650. Reinforcing pads shall have tell-tale holes of ¼" Ø. These pads shall be air tested at 1.05 kg/cm<sup>2</sup> (g), with soap solution & there after filled with hard grease in line with API 650 code.
3. All bolt holes in nozzle flanges & manholes to be straddle center lines of tank & nozzle
4. All tolerances shall be as per clause 7.5 of API – 650
5. All F.P weld to be chipped back to sound metal on the second side & rewelded.
6. Three plates joints on bottom shall not be closer than 300 mm from 1) Each other & 2) Tank Shell
7. All erection lugs & cleats to be removed before hydro test.
8. Curb angle joints shall stagger with shell joints at least by 300 mm.
9. Prj. Of nozzle shall be measured from intersection of nozzle axis & outer surface of shell/roof.
10. All weld spatters & large weld beads should be removed by grinding.
11. Flange gasket surfaces shall be 125 AARH finish, refer to project PMS.
12. Calibration & strapping shall be done in accordance with IS 2550 & 2555 or equivalent.
13. Nozzles 2" NB & below shall be provided with 2 stiffener flats of size 40 W \* 8 THK at 90° apart.
14. 300# for inlet and outlet nozzles and 300# for all instrument nozzles.
15. Water to be filled up to curb angle during hydro testing of tank.
16. All sharp corners to be rounded off.
17. Nozzles above 10" NB may be fabricated from plate with 100% radiography for welded seams.
18. Wherever the weld distance on nozzle opening or R.F pad does not comply the requirement of clause no. 5.7.2 same shall be as per fig. 5.9 of API-650.
19. Painting of tank shall be as per Engineering Design Basis Surface Preparation And Protective Coating - 20005-GEN-G-EDB-9122.
20. Testing requirement: (Test requirement mentioned here is indicative only. To be as per Specification of Storage Tank – 20005-GEN-M-SPE-4005 and API 650.)
 

Bottom Plate:	By partial vacuum T 3-5 P.S.I.G
Shell Weld:	Radiography as per API-650 Fig.8.1
Nozzle Pad on Shell only:	By air pressure at 15 P.S.I.G
Shell to Bottom:	By kerosene oil & chalk method. As per API-650 Clause no. 7.2.4.3
Tank Shell:	By filling water up to curb angle
21. Fixed Roof: As per API-650 Clause no. 7.3.7
- Electrodes: E-6013: Plates up to 12mm thick  
E-7018: Plates up to 12.5mm thick and above and shell to annular joint
22. Gauge hatch shall be non-sparking type.
23. Weight indicated is indicative only. To be confirmed by Contractor during detail engineering.
24. MOC indicated to be verified and confirmed by Contractor during detail engineering.
25. Tanks shall comply with the Project Scope Of Work, Design Basis, Specifications attached else where in the bid. Contractor to indicate the relevant documents during detail engineering.
26. Refer to respective tank GADs for additional accessories.
27. This datasheet shall be read in conjunction with Specification for Tanks – 20005-GEN-M-SPE-4005 and Engineering Design Basis for Static Equipment 20005-GEN-DB-4002.
28. Operating conditions indicated are preliminary and to be verified and updated by contractor during detail engineering.
29. Contractor to submit inspection test plan (ITP) during detail engineering for PMC approval.
30. All Nozzle size indicated in nozzle index are tentative, shall be finalized by LSTK contractor during detail engineering.

	<b>MRPL Marketing Terminal Project at Devangonhi, Bangalore</b> <b>Marketing Infrastructure Projects, MRPL</b>			
	Part – C	<b>DATASHEET FOR</b>  <b>ETHANOL TANKS</b>	Tender No. : 3200000495	
	Section – C-3		Doc No.: 20005-GEN-M-DS-4030	
Subsection – C-3.45	Rev : 1			

<b>C-3</b>	<b>SPECIFICATIONS AND DATASHEETS</b>
<b>C-3.45</b>	<b>DATASHEET FOR ETHANOL TANKS</b>

## MRPL Marketing Terminal Project at Devangonhi, Bangalore



**PROJECT :** Marketing Infrastructure Projects, MRPL

**OWNER :** MANGALORE REFINERY AND PETROCHEMICALS LTD

**PMC :** Nauvata Engineering Pvt. Ltd.



**JOB NO. :** JBG20005

Rev. No	Date	Purpose	Prepared by	Checked by	Approved by
1	04-05-2021	RE-ISSUED FOR BID	YG	KSH	KSH
0	09-03-2021	ISSUED FOR BID	YG	KSH	KSH
C1	12-12-2020	ISSUED FOR REVIEW/COMMENTS	YG	KSH	ASN

 <b>ONGC</b> ભાગલાઈ વીજળી <b>MRPL</b>	<b>MRPL Marketing Terminal Project at Devangonhi, Bangalore</b>			 <b>nauvata</b> ENGINEERING OF EXCELLENCE
	<b>Marketing Infrastructure Projects, MRPL</b>			
	Part – C	<b>DATASHEET FOR</b>	Tender No. :	
Section – C-3	Doc No.:		20005-GEN-M-DS-4030	
Subsection – C-3.45	<b>ETHANOL TANKS</b>	Rev :	1	



**DATA SHEET (ETHANOL) (CLASS A)**  
**SIZE 9.0 M. DIA X 9 M. LENGTH – 514 KL (PUMPABLE CAPACITY)**

<b>GENERAL</b>	Status: • Tender      ○ Order      ○ As Built					
	Service	Ethanol		Type of Tank	Cone Roof	
	Location	Devangonhi, Bengaluru		Nominal Diameter	9 m	
	Number of Tanks	2		Length	9 m	
	Equipment Tag Number	FB-A-06A / B		Pumpable Capacity m <sup>3</sup>	514	
			License capacity m <sup>3</sup>	550		
<b>PROCESS</b>	Medium	Ethanol		Design Liquid Sp. gr.	1.00 m	
	Specific Gravity	0.789 - 0.790		Design Liquid Level	9.0 m	
	Viscosity Cst	0.5 - 1.0 @38 °C		Tank Heating / Cooling	Not Required	
	Flash Point °C	<10		Nozzle Heating	Not Required	
	Reid Vapour Pressure Kg/cm <sup>2</sup>	0.14		Heating / Cooling Medium	Nil	
	Corrosivity			Heat load (Kw/hr.)	Nil	
	Filling Rate m <sup>3</sup> /hr.	30		Tank Mixers	Not Required	
	Emptying Rate m <sup>3</sup> /hr.	30		Water Draw off Sump	Yes	
	Storage Temp. °C	5 - 45		Tank Gauging	Single Gauge	
	Storage Pressure kPa	ATMOSPHERIC		Nitrogen Blanketing	Not Required	
	Operating Level mm	—		Ambient – Temp °C	40	
	Design Pressure kPa	ATMOSPHERIC + FULL OF LIQUID		Atmos. Press. kPa	100	
	Design Temp. °C	80		Vapour Space mm	5%	
MDMT Temp. °C	0					
<b>MECHANICAL</b>	Design & Const. Code	API-650 13TH EDITION.		Cathodic Protection	NO	
	Shell Design Method	One Foot Method		Insulation Thickness (mm)	Not Applicable	
	Design Wind Speed (m/sec)	33 (Refer Specification for Tanks - 20005-GEN-M-SPE-4005)			Not Applicable	
	Seismic Code / Zone	As per Specification for Tanks - 20005-GEN-M-SPE-4005 (Outside Seismic Zone)		Finishing & Painting	Shell:	Refer Engineering Design Basis Surface Preparation And Protective Coating
	Foundation Type	Ring Beam Foundation			Roof:	Refer Engineering Design Basis Surface Preparation And Protective Coating
	Corrosion Allowance mm	3.0 mm – 1st Shell course & Bottom Plate, 1.5 mm – Other courses & Roof plate			Bottom:	Refer Engineering Design Basis Surface Preparation And Protective Coating
	Joint Efficiency	0.85		Hydro test: As per code	By Contractor as per Specification for Tanks - 20005-GEN-M-SPE-4005	
				Insulation	Not Applicable	
	Tank Bottom Type	Cone down to Centre		External		
	Hand - Railing	Spiral Stairway & All around the roof		Access	Landing Platform	
				Clean Out Door	YES	
	Tank Roof Type	Fixed Cone		Earthing Boss	2 Nos.	
	Slope	Roof	1.12	Lightning protection		NO
		Bottom	1:100	<b>WEIGHT (Note-23)</b>		
	Stiffening Rings	As per Code		Empty Weight (MT)	25	
	Inspection & Testing (Refer Specification for Tanks - 20005-GEN-M-SPE-4005)	Hydro Test Level	Upto Full Level		Operating Weight (MT)	483.5
		Radiography	As per API 650		Test Weight (MT)	572.2
Stress Relieving		As per code				
<b>ACCESSORIES (Note-26)</b>	Level Gauge	Yes		Gauge Hatch	Yes	
	Spiral Stairway	Yes		Name Plate	Yes	
	Hand Railing (On Roof)	Yes		Atmospheric Vent Assembly	Yes	
	Earth Connection	Yes		Foam System	Yes	
	Platform at Roof	Yes		Instrumentation	Yes	
	Foam Purer Platform			Level Switch	Yes	
	Water Sprinkler	Yes				
<b>MATERIALS (Note-24)</b>	<b>BOTTOM, SHELL, ROOF &amp; REINFORCEMENT PLATE</b>	A 36 / IS:2062 Gr. B		STAIRWAY PLATFORM AND STRUCTURAL	A 36 / A 53 / IS 2062 Gr. A/B	
	SHELL / ROOF NOZZLE NECK UPTO 250 NB	A 106 Gr. B		HAND RAILING	A 53 / IS 2062 Gr. A/B	
	NOZZLE FLANGES	A 105		GRATINGS	CS GALV.	
	MAN-HOLE NECK / FLANGE / COVER PLATE	A 36 / IS 2062 Gr. B		GAUGE WELL / STILL WELL / SLEEVE	A 106 Gr. B	
	BOLTING FOR NOZZLES	A 193 Gr. B7 / A 194 Gr.2H		FITTINGS	A 234 Gr. WPB	
	BOLTING FOR STRUCTURES	A 193 Gr. B7 / A 194 Gr.2H		NAME PLATE / BRACKET	SS 304 / A 36	
	LEG PIPE SUPT. / SLEEVE	A 106 Gr. B		EARTHING CONN.	AS PER SPECIFICATIONS	
	<b>INTERNALS</b>	A 36 / IS 2062 Gr. B / A 106 Gr. B / SS304		GASKETS (PERMANENT)	SS 316 Spiral Wound Graphite Filled	
	STRUCTURES AND EXTERNALS (GUSSETS)	A 36 / IS 2062 Gr. B		SHELL / ROOF NOZZLE NECK ABOVE 250 NB	A 36	
	ANCHOR BOLTS / NUTS	A 307 Gr. B / A 563 Gr. A / IS 2062 Gr. B		INTERNAL FLOATING ROOF PANEL	Not Applicable	
	ROOF DRAIN PIPE	A 106 Gr. B		FOAM / COOLING SYSTEM PIPES	As per specification	

	<b>MRPL Marketing Terminal Project at Devangonhi, Bangalore</b> Marketing Infrastructure Projects, MRPL			
	Part - C	<b>DATASHEET FOR</b> <b>ETHANOL TANKS</b>		Tender No. : 3200000495
	Section - C-3			Doc No.: 20005-GEN-M-DS-4030
Subsection - C-3.45		Rev : 1		

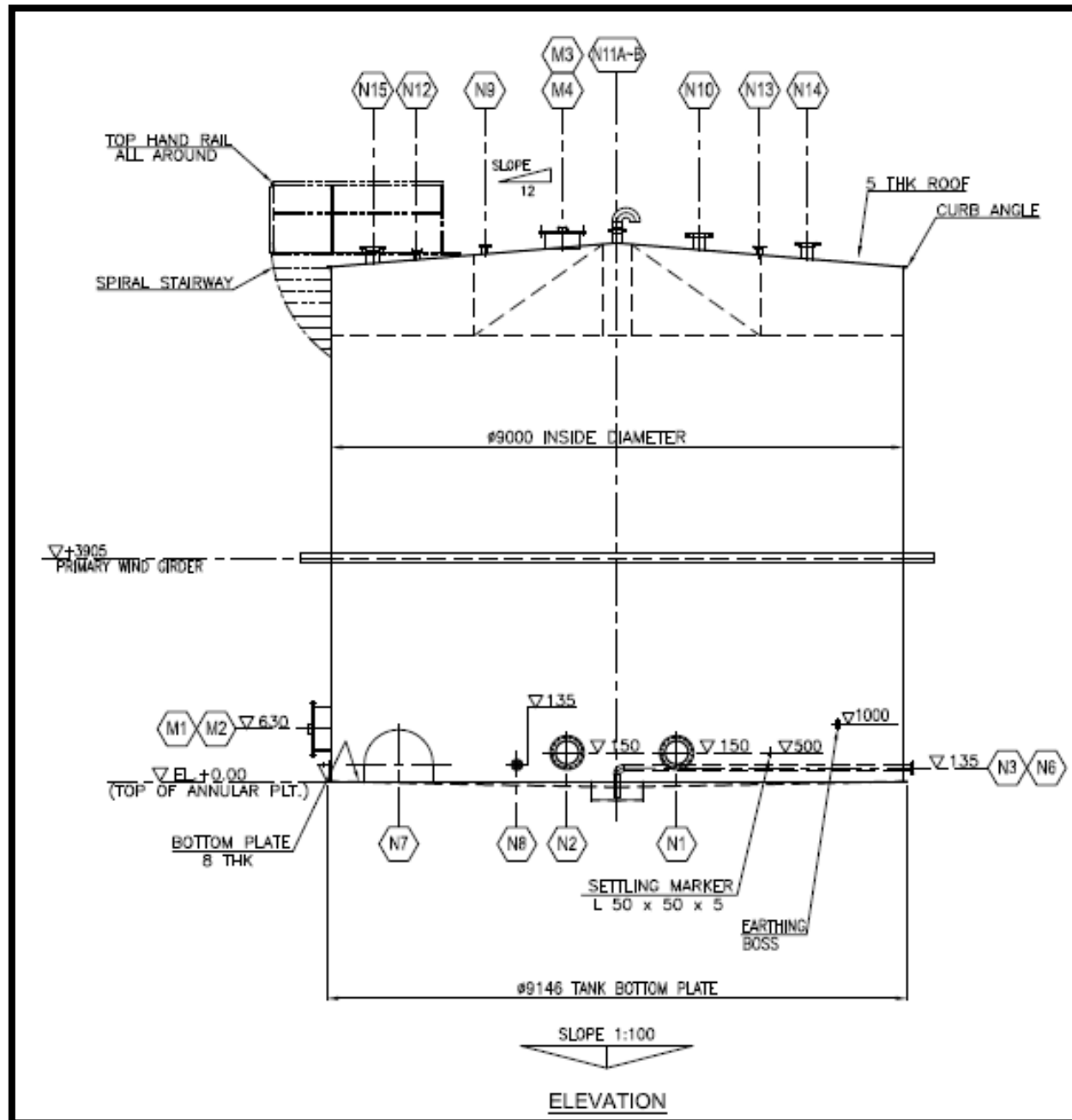
NOZZLE INDEX							
TAG	SERVICE	QTY.	NOMINALSIZ E (mm)	SCHEDU LE	THIC K (mm)	RATING / TYPE	DESCRIPTION
M1/2	SHELL MANHOLE	2	600	AS PER CODE (8 THK)			WITH COVER
N1	INLET	1	100	SCH 80	8.5	300/RF	
N2	OUTLET	1	100	SCH 80	8.5	300/RF	
N3	WATER DRAW OFF/DRAIN	1	80	SCH 80	7.6	150/RF	
N6	PRODUCT DRAW OFF	1	80	SCH 80	7.6	150/RF	
N7	CLEAN OUT DOOR	1	900 X 1200	-	8	300/RF	
N8	PRESSURE TRANSMITTER	1	50	SCH 160	8.7	300/RF	
M 3/4	ROOF MANHOLE	2	600	AS PER CODE (6 THK.)			WITH COVER
N9	TEMPERATURE TRANSMITTER	1	75	SCH 40	5.1	300/RF	
N10	LEVEL TRANSMITTER	1	200	SCH 40	8.1	300/RF	RADAR TYPE
N 11A-B	ROOF VENT	2	150	SCH 40	6.2	150/RF	
N12	LEVEL TRANSMITTER	1	200	SCH 40	8.1	300/RF	RADAR TYPE
N13	LEVEL SWITCH	1	80	SCH 80	7.6	150/RF	
N14	DIP HATCH	1	200	SCH 40	8.1	150/RF	WITH COVER
N15	SPARE	1	100	SCH 40	6.2	300/RF	



 	<b>MRPL Marketing Terminal Project at Devangonhi, Bangalore</b>		
	<b>Marketing Infrastructure Projects, MRPL</b>		
	Part – C	<b>DATASHEET FOR</b>	
Section – C-3	Doc No.: 20005-GEN-M-DS-4030		
Subsection – C-3.45	<b>ETHANOL TANKS</b>	Rev : 1	

## DATA SHEET – ETHANOL STORAGE TANKS

### NOTES

1. All dimensions are in MM unless otherwise specified.
2. Nozzles above 2" NB shall be provided with reinforcement pads as per API-650. Reinforcing pads shall have tell-tale holes OF ¼" Ø. These pads shall be air tested at 1.05 kg/cm<sup>2</sup> (g), with soap solution & there after filled with hard grease in line with API 650 code.
3. All bolt holes in nozzle flanges & manholes to be straddle center lines of tank & nozzle
4. All tolerances shall be as per API – 650
5. All F.P weld to be chipped back to sound metal on the second side & rewelded.
6. Three plates joints on bottom shall not be closer than 300 mm from 1) Each other & 2) Tank Shell
7. All erection lugs & cleats to be removed before hydro test.
8. Curb angle joints shall stagger with shell joints at least by 300 mm.
9. Prj. Of nozzle shall be measured from intersection of nozzle axis & outer surface of shell/roof.
10. All weld spatters & large weld beads should be removed by grinding.
11. Flange gasket surfaces shall be 125 AARH finish, refer to project PMS
12. Calibration & strapping shall be done in accordance with IS 2550 & 2555 or equivalent.
13. Nozzles 2" NB & below shall be provided with 2 stiffener flats of size 40 W \* 8 THK at 90° apart.
14. 300# for inlet and outlet nozzles and 300# for all instrument nozzles.
15. Water to be filled up to curb angle during hydro testing of tank.
16. All sharp corners to be rounded off.
17. Nozzles above 10" NB may be fabricated from plate with 100% radiography for welded seams.
18. Wherever the weld distance on nozzle opening or R.F pad does not comply the requirement of clause no. 5.7.2 same shall be as per fig. 5.9 of API-650.
19. Painting of tank shall be as per Engineering Design Basis Surface Preparation And Protective Coating - 20005-GEN-G-EDB-9122.
20. Testing requirement: (Test requirement mentioned here is indicative only. To be as per Specification of Storage Tank – 20005-GEN-M-SPE-4005 and API 650.)
 

Bottom Plate:	By partial vacuum T 3-5 P.S.I.G
Shell Weld:	Radiography as per API-650 Fig.8.1
Nozzle Pad on Shell only:	By air pressure at 15 P.S.I.G
Shell to Bottom:	By kerosene oil & chalk method. As per API-650 Clause no. 7.2.4.3
Tank Shell:	By filling water up to curb angle
21. Fixed Roof: As per API-650 Clause no. 7.3.7
- Electrodes: E-6013: Plates up to 12mm thick  
E-7018: Plates up to 12.5mm thick and above and shell to annular joint
22. Gauge hatch shall be non-sparking type.
23. Weight indicated is indicative only. To be confirmed by Contractor during detail engineering.
24. MOC indicated to be verified and confirmed by Contractor during detail engineering.
25. Tanks shall comply with the Project Scope Of Work, Design Basis, Specifications attached else where in the bid. Contractor to indicate the relevant documents during detail engineering.
26. Refer to respective tank GADs for additional accessories.
27. This datasheet shall be read in conjunction with Specification for Tanks – 20005-GEN-M-SPE-4005 and Engineering Design Basis for Static Equipment 20005-GEN-DB-4002.
28. Operating conditions indicated are preliminary and to be verified and updated by contractor during detail engineering.
29. Contractor to submit Inspection Test Plan (ITP) during detail engineering for PMC approval.
30. All Nozzle size indicated in nozzle index are tentative, shall be finalized by LSTK contractor during detail engineering.

DRAWING NO.: 20005-PR-0001

ALL RIGHTS RESERVED. NO PART OF THIS DRAWING MAY BE REPRODUCED / STORED IN RETRIEVAL SYSTEM OR TRANSMITTED IN ANY FORM OR BY ANY MEANS ELECTRONIC, MECHANICAL, PHOTOCOPIING, XEROXING OR OTHERWISE WITHOUT PRIOR PERMISSION FROM NAUVATA ENGINEERING LTD./MRPL

**GENERAL NOTES {INDICATIVE ONLY ,TO BE CONFIRMED BY CONTRACTOR DURING DETAIL ENGINEERING}:-**

1. ALL DIMENSIONS ARE IN MM UNLESS OTHERWISE NOTED.
2. BOLT HOLES SHALL STRADDLE CENTRE LINE.
3. FLANGE DIMENSION SHALL CONFORM TO ANSI B 16.5 UP TO 600 NB
4. ALL VERTICAL & HORIZONTAL SHELL WELD JOINTS SHALL BE FULL PENETRATION & FULL FUSION BUTT WELDS.
5. BOTTOM PLATES ARE OF SINGLE WELDED FILLET LAP JOINT CONSTRUCTION & SAME APPLIES TO ROOF PLATE JOINTS.
6. FLANGE GASKET FACE SHALL HAVE SERRATED FINISH WITH CONCENTRIC GROOVES.
7. THICKNESS OF GASKET SHALL BE 1.5 mm FOR NOZZLES UPTO 450 NB AND 3.0mm FOR NOZZLES ABOVE 450 NB.
8. STRAPPING & CALIBRATION SHALL BE DONE IN ACCORDANCE WITH IS.2007 & 2008(LATEST EDITION)
9. FOR WELDING E 308-16 ELECTRODE SHALL BE USED.
10. OPERATING CONDITIONS INDICATED ARE PRELIMINARY AND TO BE VERIFIED & UPDATED DURING DETAIL ENGINEERING.
11. WEIGHT INDICATED TO BE INDICATIVE ONLY. TO BE CONFIRMED BY CONTRACTOR DURING DETAIL ENGINEERING.
12. THIS DRAWING IS INDICATIVE ONLY. CONTRACTOR/VENDOR TO DEVELOP TANK GA FABRICATION DRAWING DURING DETAIL ENGINEERING & SUBMIT FOR PMC/COMPANY APPROVAL.
13. MOC INDICATED TO BE VERIFIED AND CONFIRMED BY CONTRACTOR DURING DETAIL ENGINEERING
14. DRAWING & DRAWING DETAILS ARE PRELIMINARY AND TO BE VERIFIED & UPDATED BY CONTRACTOR DURING DETAIL ENGINEERING.
15. RING BEAM DESIGN SHALL BE CHECKED FOR SLENDERNESS BY LSTK CONTRACTOR

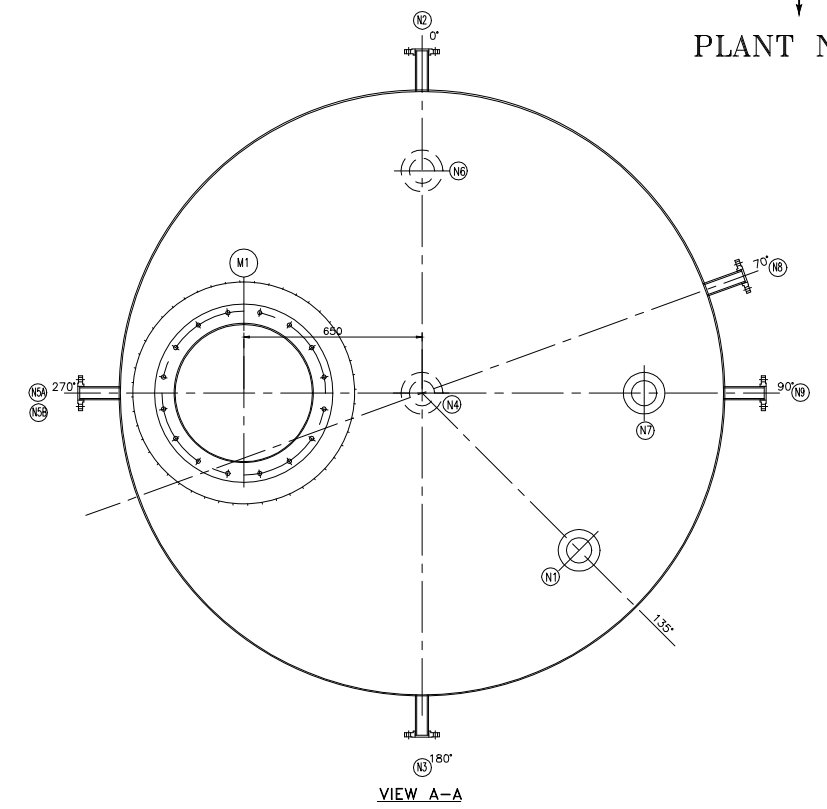
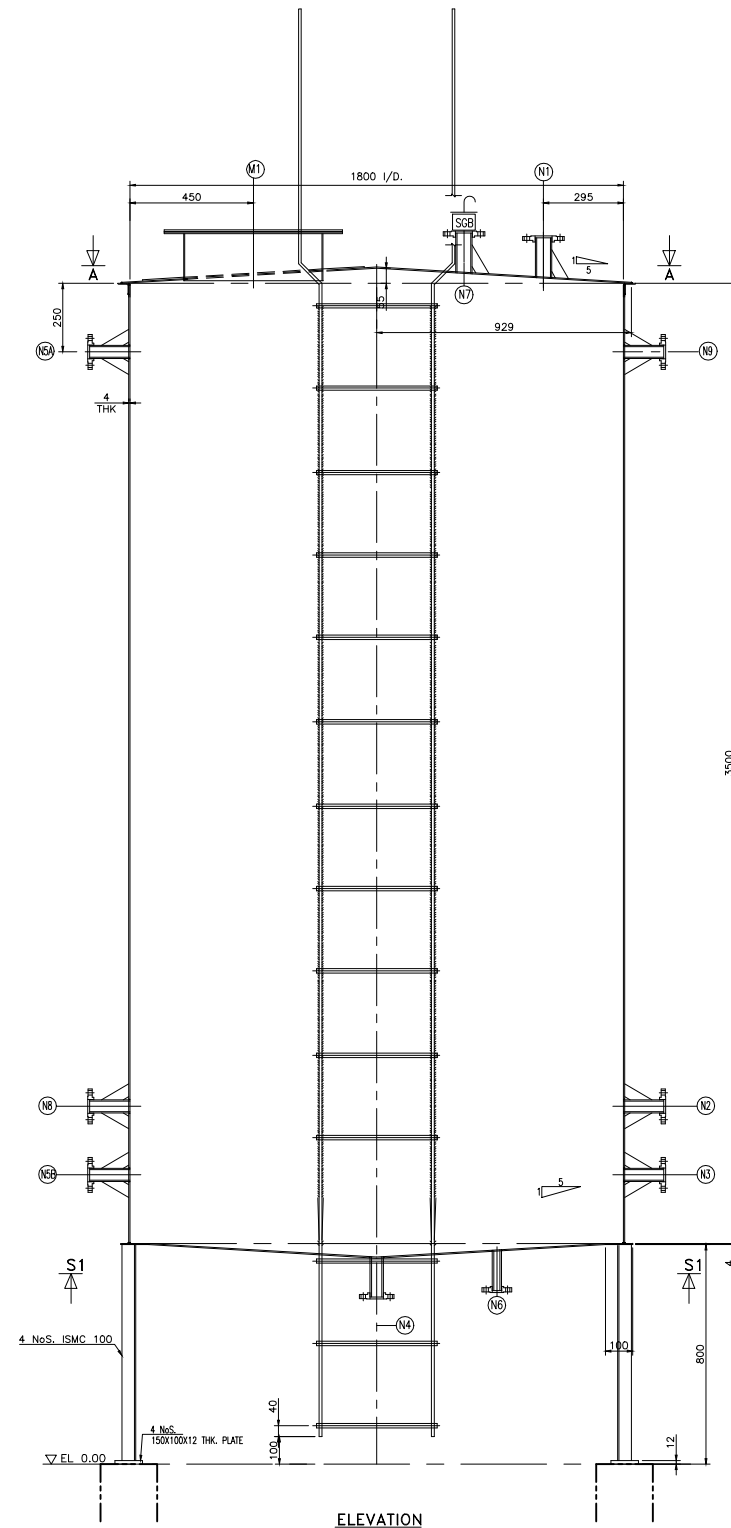

DESIGN DATA {NOTE-10}	
DESIGN CODE	GOOD ENGINEERING PRACTICE/AS PER SPEC
ITEM NO.	FA-A-11A/B
STORED PRODUCT	FOAM TANK
SIZE OF TANK	INSIDE DIAMETER-1,800 M & LENGTH-3,000 M
TYPE OF TANK	HORIZONTAL
DESIGN PRESSURE (INT./EXT.) (kg/cm <sup>2</sup> )	ATMOSPHERIC + FULL OF LIQUID
OPERATING PRESSURE (kg/cm <sup>2</sup> )	ATMOSPHERIC
CORROSION ALLOWANCE	-
DESIGN FILLING HEIGHT OF PRODUCT m	1,850
MAXIMUM FILLING HEIGHT OF PRODUCT m	1,850
SPECIFIC GRAVITY OF LIQUID	1.025 TO 1.045
NoS. OF TANKS	02
DESIGN TEMPERATURE (°C)	65
OPERATING TEMPERATURE (°C)	40
POST WELD HEAT TREATMENT	NIL
INSULATION/THK.	NIL
JOINT EFFICIENCY	AS PER CODE
RADIOGRAPHY	SPOT/SPOT
TESTINGS	AS PER CODE
NOMINAL CAPACITY (KL)	07
FLASH POINT (°C)	-
HYDROSTATIC PRESSURE (kg/cm <sup>2</sup> )	AS PER CODE
WIND DESIGN	-
SEISMIC DESIGN	(REFER SPEC OF TANKS-20005-GEN-M-SPE-4005)
SURFACE PREPARATION & PAINTING	REFER PAINTING SPECIFICATION
INSPECTION	CLIENT/TPI
EMPTY WEIGHT M.T.	~1.71
OPERATING WEIGHT M.T.	~9.67
HYDROTEST WEIGHT M.T.	~11.14

**NOZZLE SCHEDULE {INDICATIVE ONLY, TO BE CONFIRMED BY CONTRACTOR DURING DETAIL ENGINEERING}:-**

NOZZLE MARK	SIZE NB	SCH. THK	QTY.	FLANGES RATING TYPE FACE	PROJ.	SERVICE	REM.
N1	50	SCH.40	01	150# WN R.F	150	RECIRCULATION	
N2	50	SCH.40	01	150# WN R.F	150	INLET	
N3	50	SCH.40	01	150# WN R.F	150	OUTLET	
N4	50	SCH.40	01	150# WN R.F	150	SPARE (OUTLET)	
NSA/B	50	SCH.40	02	300# WN R.F	150	LEVEL INDICATOR	
N6	25	SCH.80	01	150# WN R.F	150	DRAIN	
M1	500	6 THK	01	150# WN R.F	150	SHELL MANHOLE WITH COVER	
N7	25	SCH.40	02	150# WN R.F	150	VENT WITH SILICA GEL BREATHER	
N8	75	SCH.80	01	150# WN R.F	150	SPARE	
N9	75	SCH.40	01	150# WN R.F	150	OVERFLOW	

**MATERIAL SPECIFICATION {NOTE 13}**

DESCRIPTION	MATERIAL OF CONSTRUCTION
SHELL, END & REINFORCEMENT PLATE	SA240 TYP 304
MANWAY NECKS / FLANGE / COVER	SA240 TYP 304
NOZZLE NECKS UPTO 250 NB	SA 312 TP304
NOZZLE FLANGES	SA 182 F 304
BOLTING FOR NOZZLES & MANHOLE	SA 312 TP 304/SA 240 TYP 304/AS PER PMS
BOLTING FOR STRUCTURES	IS 1363/AS PER PMS
GASKETS	SS316 SPIRAL WOUND GRAPHITE FILLED/AS PER PMS
STRUCTURES	SA240 TYP 304/AS PER PMS
EXTERNALS GUSSET / PAD PLATE	SA240 TYP 304
FITTINGS	-
PAD FOR LIFTING LUG	SA240 TYP 304
LIFTING BOLT	IS 1363
WEAR PLATE	SA240 TYP 304
BRACKET	SA240 TYP 304
EARTHING CONNECTION	AS PER ELECTRICAL SPECIFICATION

REV.	DATE	DESCRIPTION	DRWN	CHKD	APPRD	MRPL
1	08-APR-21	RE-ISSUED FOR BID	YG	KSH	KSH	
0	20-JAN-21	ISSUE FOR BID	YG	KSH	KSH	
C1	21-DEC-20	ISSUE FOR REVIEW/COMMENTS	BN	YG	KSH	

CLIENT:  
 **MANGALORE REFINERY AND PETROCHEMICALS LIMITED**  
 (A subsidiary of Oil & Natural Gas Corp. Ltd - ONGC)

PROJECT:  
**CONSTRUCTION OF MARKETING TERMINAL PROJECT AT DEVANGONTHI, BANGALORE.**

PROJECT MANAGEMENT CONSULTANT:  
 **NAUVATA ENGINEERING PVT. LTD.**

DRAWING TITLE: **GENERAL ARRANGEMENT DRAWING FOR FOAM TANK**

CLIENT TENDER No:	DRAWING No:	SHT NO.	REV	SCALE:
	20005-GEN-M-DW-4100	1 OF 1	1	1:1

**GENERAL NOTES (INDICATIVE ONLY, TO BE CONFIRMED BY CONTRACTOR DURING DETAIL ENGINEERING):-**

- ALL DIMENSIONS ARE IN MM UNLESS OTHERWISE SPECIFIED.
- ALL BUTT WELD SEAMS WITHOUT BACKING STRIP SHALL BE CHIPPED BACK TO SOUND METAL & REWELD.
- MANHOLE AND NOZZLE NECK 600NB AND ABOVE MAY BE FABRICATED FROM PLATE AND SHALL BE 100% RADIOGRAPHED.
- ALL NOZZLE 50NB AND BELOW SHALL BE STIFFENED BY 2 NOS, 50x6THK FLAT 90° APART.
- ALL NOZZLE AND MANHOLE BOLTS SHALL STRADDLE THE NEUTRAL AXIS OF EQUIPMENT.
- THE NOZZLE ABOVE 50NB SHALL BE PROVIDED WITH REINFORCEMENT PAD AS PER CODE.
- UNLESS OTHERWISE SPECIFIED, NOZZLE FLANGE SHALL CONFIRM TO ANSI/ASME B16, CLASS 150 FOR SIZES UPTO 600NB AND TO ASME B16.47 CLASS 150 FOR SIZES ABOVE 600NB.
- ALL COMPENSATION RINGS AND PADS SHALL BE PNEUMATICALLY TESTED WITH AIR AT 100 KPa(G) BY APPLYING SOAP SOLUTION ON OUTSIDE WELD. ALL REINFORCEMENT PADS SHOULD HAVE 6Ø TELL-TALE ON HORIZONTAL CENTERLINE.
- PROJECTION OF SHELL NOZZLE ARE MENTIONED FROM OUTSIDE DIAMETER OF TANK / OUTER SURFACE OF ROOF TO NOZZLE FLANGE FACE (i.e. GASKET SEATING FACE).
- DIMENSIONAL TOLERANCES SHALL BE IN ACCORDANCE WITH CLAUSE 7.5 OF API 650.
- VERTICAL JOINTS IN ADJACENT SHELL COURSES SHALL NOT BE IN ALIGNMENT BUT SHALL BE OFFSET FROM EACH OTHER BY 1/3RD OF THE PLATE LENGTH BUT IN NO CASE LESS THAN A DISTANCE OF 300 mm.
- GAUGE HATCH, TEMPERATURE ELEMENT & LEVEL TRANSMITTER SHOULD BE LOCATED AWAY FROM THE INLET AND OUTLET NOZZLE.
- ELECTRODES:- E-6013 : PLATES UP TO 12 THK.  
E-7018 : PLATES 12.5 THK AND ABOVE AND SHELL TO ANNULAR JOINT.
- THE TANKS SHALL BE MANUFACTURED, INSPECTED / TESTED, ERECTED & PAINTED AS PER LISTED SPECIFICATION
- EARTHING BOSS SHALL BE PROVIDED AS PER STD - BR/CR/236 & OISD 244.
- FABRICATOR HAS TO DESIGN, FABRICATE, SUPPLY, INSTALL ERECT AND COMMISSION THE FROM POURER SYSTEM ALONG WITH FOAM TANK AND OTHER ACCESSORIES AND WATER SPRINKLER SYSTEM AS PER SPECIFICATION.
- THE COOLING RING NUMBERS & ELEVATION SHOWN IN DRAWING ARE INDICATIVE FOR REPRESENTATION PURPOSE ONLY.
- EACH FOAM POURER NOZZLE TO BE PROVIDED WITH A PLATFORM OF SIZE 1.5M x 1.5M WITH RAILING AND A MONKEY LADDER TO ACCESS THE PLATFORM FROM THE ROOF TOP.
- FREE VENT TO BE DESIGN FOR FLOW RATE, IN-2500 KL/hr, OUT-2000 KL/hr
- VENT SHALL BE CONSIDERED AS PER API 2000 APPLICABLE FOR API 650 OR TANK SHALL BE EQUIPPED WITH WEAK ROOF TO SHELL ATTACHMENT (FRAGILE JOINT) AS PER API 650 REQUIREMENTS.
- TANK ACCESSORIES ARE INDICATIVE, TO BE VERIFIED & UPDATED BY CONTRACTOR DURING DETAIL ENGINEERING.
- WEIGHT INDICATED TO BE INDICATIVE ONLY, TO BE CONFIRMED BY CONTRACTOR DURING DETAIL ENGINEERING.
- OPERATING CONDITIONS INDICATED ARE PRELIMINARY AND TO BE VERIFIED & UPDATED BY CONTRACTOR DURING DETAIL ENGINEERING.
- THIS DRAWING IS INDICATIVE ONLY, CONTRACTOR/VENDOR TO DEVELOP TANK GA FABRICATION DRAWING DURING DETAIL ENGINEERING & SUBMIT FOR PMC/COMPANY APPROVAL.
- MOC INDICATED TO BE VERIFIED AND CONFIRMED BY CONTRACTOR DURING DETAIL ENGINEERING
- DRAWING & DRAWING DETAILS ARE PRELIMINARY AND TO BE VERIFIED & UPDATED BY CONTRACTOR DURING DETAIL ENGINEERING.
- RING BEAM DESIGN SHALL BE CHECKED FOR SLENDERNESS BY LSTK CONTRACTOR

**NOTES FOR ALUMINIUM INTERNAL FLOATING ROOF DETAIL ENGINEERING):-**

- THE ROOF SHALL BE PROVIDED WITH THE ACCESSORIES LIKE ANTI ROTATION CABLES, GROUNDING CABLES, GAUGE/ GUIDE WELLS, PRESSURE VACUUM VENTS, ETC.
- THE GUIDE WELL SIZES, THICKNESS, PROJECTION FROM DECK SHALL BE DECIDED BY THE VENDOR & ALL GUIDE WELLS SHALL BE PROPERLY SEALED.
- THE ORIENTATION OF THE SUPPORTS LEGS SHALL BE SUCH THAT THEY DO NOT COLLIDE WITH THE FIXED ROOF SUPPORTING STRUCTURE.
- THE FLOATING ROOF ARRANGEMENT SHOWN IS INDICATIVE. THE FABRICATOR SHALL FINALIZE THE ACCESSORIES & SIZING OF THE ROOF.

**MATERIAL SPECIFICATION (NOTE 25)**

BOTTOM, SHELL, ROOF & REINFORCEMENT PLATE	A36/IS 2062 Gr B
SHELL/ROOF NOZZLE NECK UP TO 250 NB.	SA 106 Gr.B
NOZZLE FLANGES	SA 105
MANHOLE NECK / FLANGE / COVER PLATE	A36/IS 2062 Gr B
SHELL NOZZLE NECK ABOVE 250 NB.	A36/IS 2062 Gr B
ROOF NOZZLE NECK ABOVE 250 NB.	A36/IS 2062 Gr B
BOLTING FOR NOZZLES	SA 193 Gr.B7/ 194 Gr.2H/AS PER PMS
BOLTING FOR STRUCTURES	SA 193 Gr.B7/ 194 Gr.2H/AS PER PMS
GASKETS	SS316 SPIRAL WOUND GRAPHITE FILLED/ AS PER PMS
INTERNALS	A36/IS 2062 Gr B /A 106 Gr.B/SS304
STRUCTURES AND EXTERNALS (GUSSETS)	A36/IS 2062 Gr B
STAIRWAY PLATFORM AND STRUCTURAL	A36/A53/IS 2062 Gr A/B
HAND RAILING	A53/IS 2062 Gr A/B
GRATINGS	CS GALV
GAUGE WELL / STILL WELL/SLEEVE	SA 106 Gr.B
FITTINGS	SA 234 Gr.WPB
NAME PLATE / BRACKET	A36/SS 304
EARTHING CONN.	AS PER ELECTRICAL SPECIFICATION
LEG PIPE SUPT. / SLEEVE	SA 106 Gr.B
ROOF DRAIN PIPE	SA 106 Gr.B
FOAM / COOLING SYSTEM PIPES	AS PER PMS
INTERNAL FLOATING ROOF PANEL	ALUMINIUM
ANCHOR BOLTS	A307 Gr.B/A563 Gr.A/IS 2062 Gr.B

**ACCESSORIES (NOTE 21)**

ACCESSORIES	SUPPLIED BY
ACCESS TO ROOF (SPIRAL STAIRWAY)	FABRICATOR
HANDRAIL AT TANK ROOF (ALL AROUND)	FABRICATOR
EARTHING BOSS WITH PIT	FABRICATOR
PLATFORM AT SHELL TOP AS PER STD	FABRICATOR
SAMPLING DEVICE (GAUGE HATCH)	FABRICATOR
LEVEL INDICATOR (ELECTRONIC)	FABRICATOR
TEMPERATURE INSTRUMENT	FABRICATOR
COOLING SYSTEM INCLUDING SPRAY NOZZLE	FABRICATOR
FOAM SYSTEM	FABRICATOR
FOAM MAKER & ORIFICE PLATE	FABRICATOR
STILL WELL / INTERNALS	FABRICATOR
GASKETS FOR SHELL & FIXED ROOF NOZZLES	FABRICATOR
GASKET FOR FLOATING ROOF NOZZLES	FABRICATOR
TANK PRIMARY & SECONDARY SEAL	FABRICATOR
SUPPORTS FOR FLOATING ROOF	FABRICATOR
FLOATING ROOF COMPONENTS	FABRICATOR
PRESSURE TRANSMITTER	FABRICATOR
LEVEL INDICATOR	FABRICATOR
JET MIXER	FABRICATOR

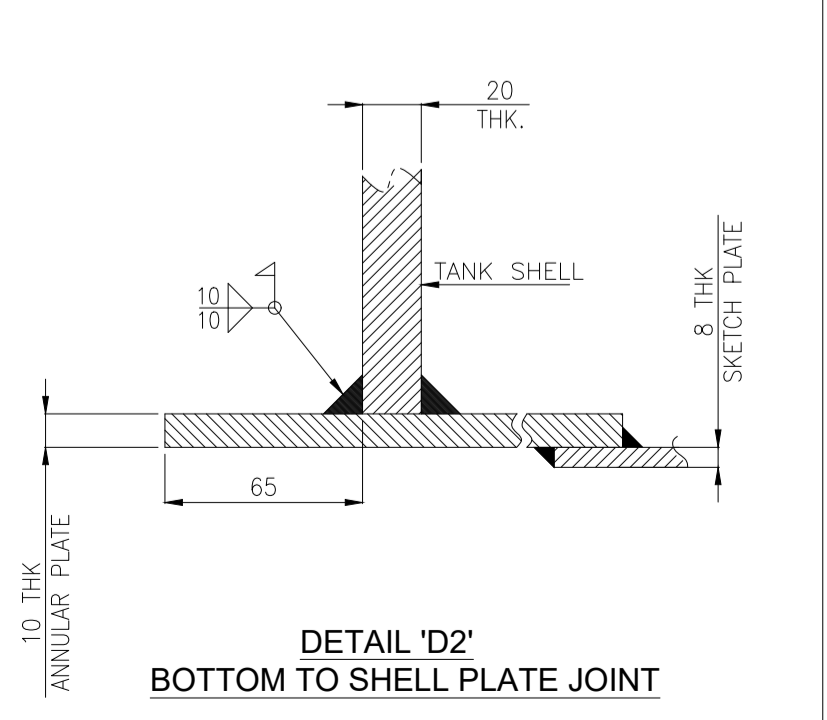
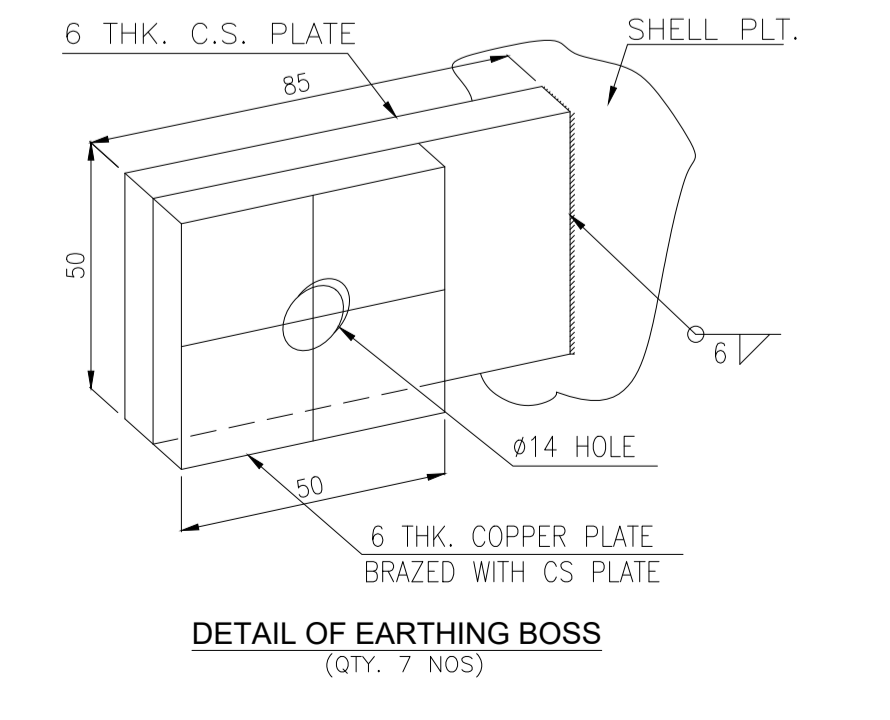
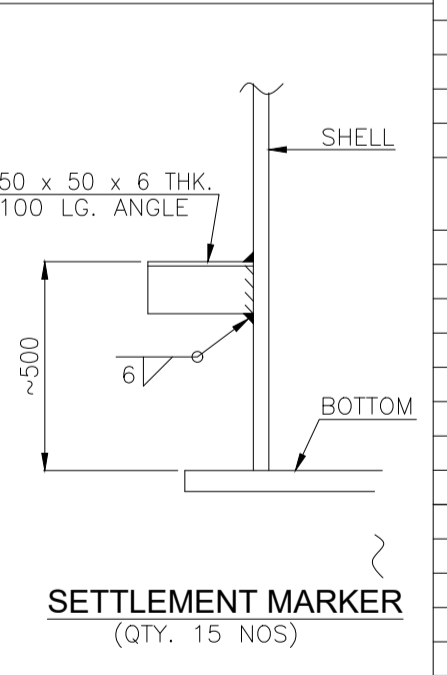
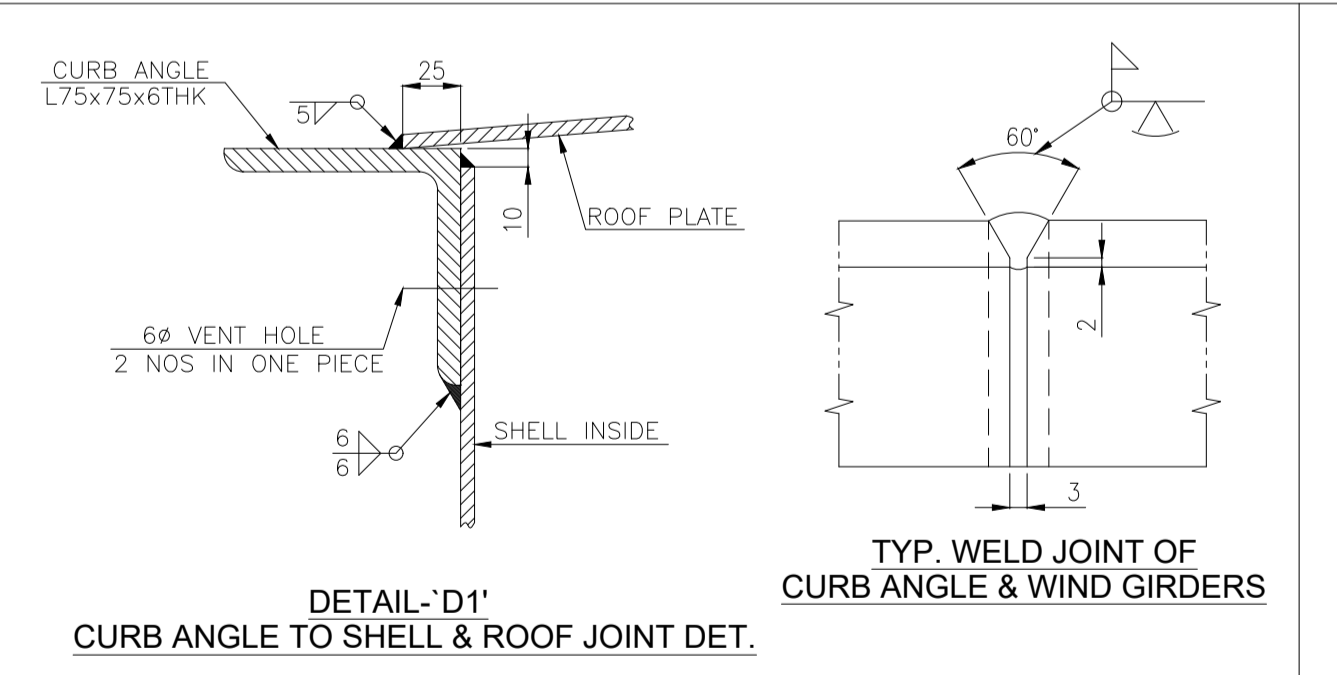
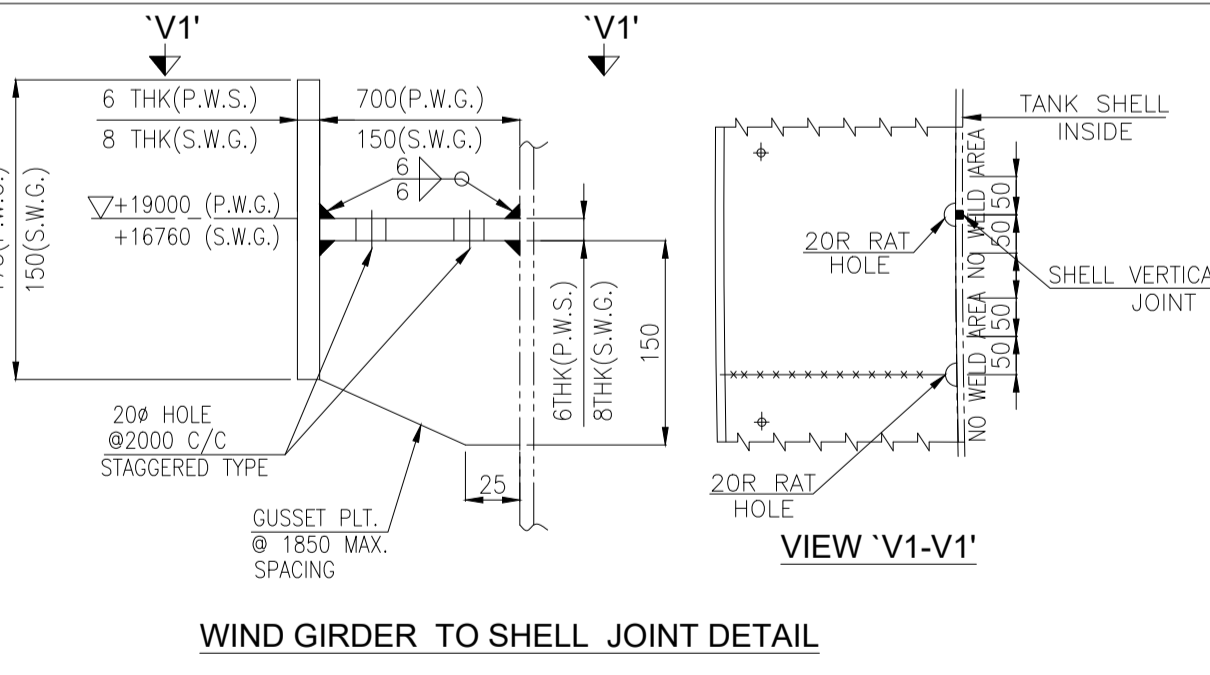
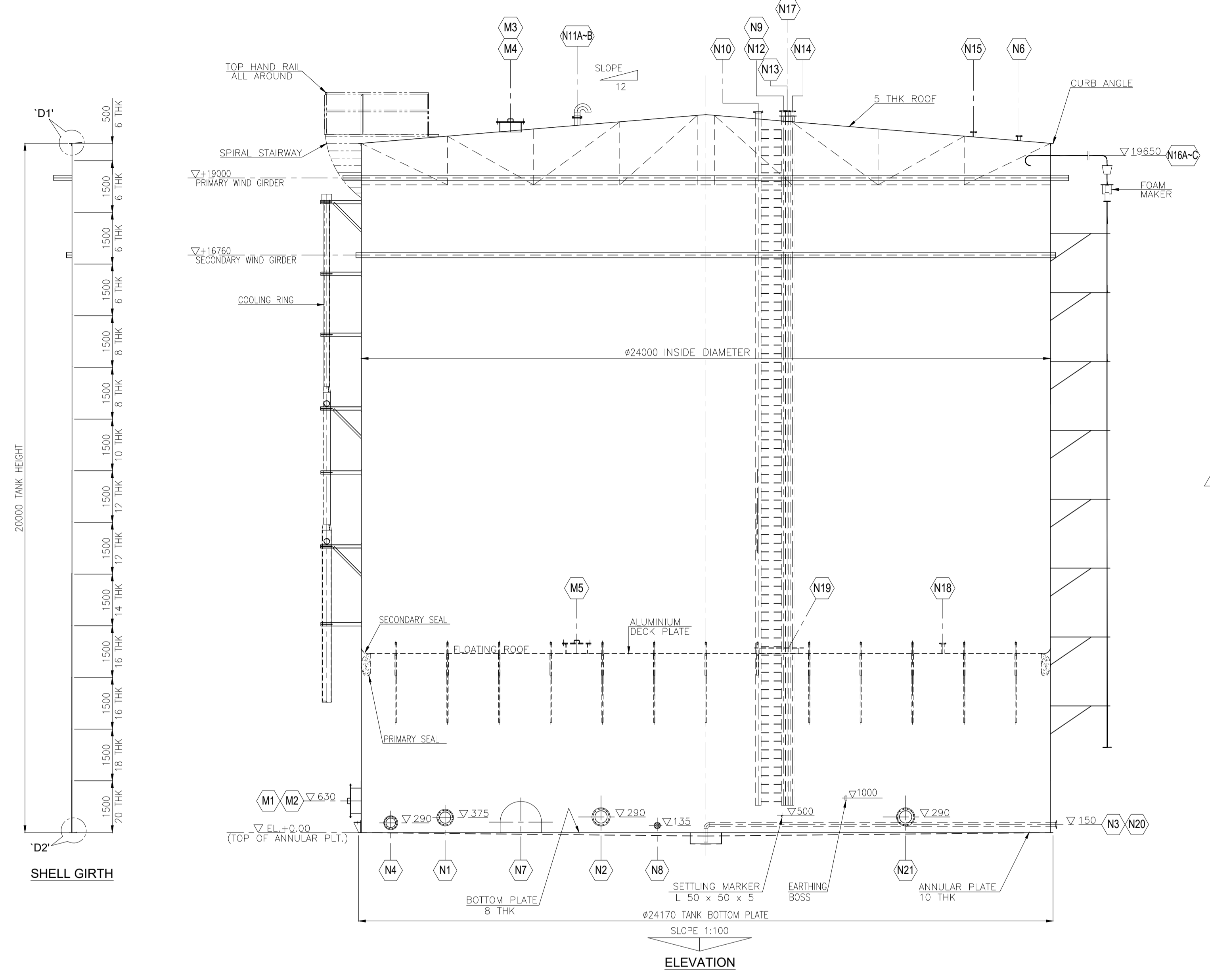

**NOZZLE SCHEDULE (INDICATIVE ONLY, TO BE CONFIRMED BY CONTRACTOR DURING DETAIL ENGINEERING):-**

MARK	NOZZLE SIZE	SCH/THK	QTY.	FLANGE		PROJ.	SERVICE
				RTG.	FACE		
M1/2	600	8 THK	02	AS PER CODE		300	SHELL M/H WITH COVER
N1	350	80/19.0	01	300#	SO	RF	250 INLET
N2	250	80/15.9	01	300#	SO	RF	225 OUTLET
N3	100	80/8.5	01	150#	SO	RF	175 WATER DRAW OFF
N4	250	80/15.9	01	150#	SO	RF	225 RECIRCULATION WITH JET MIXER
N7	900x1200	20 THK	01	AS PER CODE		-	CLEAN OUT DOOR
N8	50	160/8.7	01	300#	SO	RF	150 PRESSURE TRANSMITTER
N16A-C	200	80/12.7	03	150#	SO	RF	200 FOAM POURER WITH DEFLECTOR
N20	100	80/8.5	01	150#	SO	RF	175 PRODUCT DRAW OFF
N21	250	80/15.9	01	300#	SO	RF	225 OUTLET-2
M3/4	600	6 THK	02	AS PER CODE		-	ROOF MANHOLE WITH COVER
N5	-	-	-	-	-	-	DELETED
N6	150	80/7.1	01	150#	SO	RF	- VRU
N9	75	80/5.1	01	300#	SO	RF	- TEMPERATURE ELEMENT
N10	200	40/8.1	01	300#	SO	RF	- LEVEL TRANSMITTER (RADAR TYPE)
N11A-B	300	40/10.3	02	150#	SO	RF	- ROOF VENT
N12	200	40/8.1	01	300#	SO	RF	- LEVEL TRANSMITTER (RADAR TYPE)
N13	80	80/7.6	01	300#	SO	RF	- LEVEL SWITCH
N14	200	40/5.4	01	150#	SO	RF	- DIP HATCH WITH COVER
N15	100	40/6.2	01	150#	SO	RF	- SPARE
N17	500	40/15.9	01	150#	SO	RF	- STILL WELL
M5	600	5 THK	01	AS PER CODE		-	DECK THROUGH MANWAY
N18	80	40/5.4	01	150#	SO	RF	- RUPTURE DISC **
N19	-	-	01	150#	SO	RF	- GUIDE WELL

\*\* IFR MANUFACTURER TO CHECK THE NUMBER OF REQUIRED RUPTURE DISC

1	05-MAY-21	RE-ISSUE FOR BID	YG	KSH	ASN
0	08-FEB-21	ISSUE FOR BID	YG	KSH	ASN
C1	21-DEC-20	ISSUE FOR REVIEW/COMMENTS	BN	YG	KSH

CLIENT: **ONGC MANGALORE REFINERY AND PETROCHEMICALS LIMITED**  
(A subsidiary of Oil & Natural Gas Corpn. Ltd - ONGC)

PROJECT: **CONSTRUCTION OF MARKETING TERMINAL PROJECT AT DEVANGONTHI, BANGALORE.**

PROJECT MANAGEMENT CONSULTANT: **nauvata ENGINEERING PVT. LTD.**

DRAWING TITLE: **GENERAL ARRANGEMENT DRAWING FOR MS TANK (FB-A-01A/B/C) 24.000 MTR DIA. x 20.000 MTR HT.**

CLIENT TENDER No:	DRAWING No:	SHT NO.	REV	SCALE:
320000428	20005-GEN-M-DW-4101	1 OF 1	1	1:1

ALL RIGHTS RESERVED. NO PART OF THIS DRAWING MAY BE REPRODUCED / STORED IN RETRIEVAL SYSTEM OR TRANSMITTED IN ANY FORM OR BY ANY MEANS ELECTRONIC, MECHANICAL, PHOTOCOPYING, XEROXING OR OTHERWISE WITHOUT PRIOR PERMISSION FROM NAUVATA ENGINEERING LTD./MRPL

DRAWING NO.: 20005-PR-0001

DESIGN DATA (NOTE-21)

DESIGN CODE	API-650, LATEST EDITION
STORED PRODUCT	HSD (CLASS-B)
SIZE OF TANK	INSIDE DIAMETER-24,000 M & HEIGHT-20,000 M
CAPACITY (PUMPABLE/LICENSE)	M <sup>3</sup> 8324/8550
NOS OF TANK	THREE
TYPE OF ROOF	CONE ROOF
CORROSION ALLOWANCE	3.0MM, OTHER-1ST SHELL COURSE & BOTTOM PLATE 1.5MM-OTHERS COURSES & ROOF PLATE
LIQUID DENSITY	KG/M <sup>3</sup> 820 TO 880
MAX. DESIGN LIQUID LEVEL	M 20.0
DESIGN (POSITIVE) PRESSURE	MM WC ATMOSPHERIC + FULL OF LIQUID
OPERATING PRESSURE	MM WC ATMOSPHERIC
DESIGN TEMPERATURE	°C 80
OPERATING TEMPERATURE	°C 45
MDMT TEMPERATURE	°C 0
TEST PRESSURE	KG/CM <sup>2</sup> g FULL OF WATER
JOINT EFFICIENCY	AS PER CODE
RADIOGRAPHY	AS PER CODE
FLASH POINT	°C 32-66
WIND SPEED	M/Sec 33(REFER SPEC OF TANKS-20005-GEN-M-SPE-4005)
WIND PRESSURE	KG/M <sup>2</sup> (REFER SPEC OF TANKS-20005-GEN-M-SPE-4005)
SEISMIC / ZONE	AS PER SPEC OF TANKS-20005-GEN-M-SPE-4005 (OUTSIDE SEISMIC ZONE)
PAINING	REFER PAINTING SPECIFICATION
INSULATION / THK	NIL/-
FLOW RATE (IN/OUT)	m <sup>3</sup> /hr. 1050/1080
INSPECTION	CLIENT / TPI
EMPTY WEIGHT	M.T. ~ 236.0
OPERATING WEIGHT	M.T. ~ 7641.5
HYDROTEST WT.	M.T. ~ 9279.2

NOZZLE SCHEDULE (INDICATIVE ONLY, TO BE CONFIRMED BY CONTRACTOR DURING DETAIL ENGINEERING):-

MARK	NOZZLE			QTY.	FLANGE			PROJ.	SERVICE
	SIZE	SCH/THK	RTG.		TYPE	FACE			
M1/2	600	8 THK	02	AS PER CODE	SO	RF	300	SHELL M/H WITH COVER	
N1	350	80/19.0	01	300#	SO	RF	250	INLET	
N2	400	80/21.4	01	300#	SO	RF	250	OUTLET	
N3	100	80/8.5	01	150#	SO	RF	175	WATER DRAW OFF	
N4	250	80/10.9	01	150#	SO	RF	225	REDUCULATION WITH JET MIXER	
N6	100	80/8.5	01	150#	SO	RF	175	PRODUCT DRAW OFF	
N7	900x1200	20 THK	01	AS PER CODE	SO	RF	-	CLEAN OUT DOOR	
N8	50	160/8.7	01	150#	SO	RF	150	PRESSURE TRANSMITTER	
N16A-C	250	80/15.9	03	150#	SO	RF	225	FOAM POURER WITH DEFLECTOR	
N17	400	80/21.4	01	300#	SO	RF	250	OUTLET-2	
M3/4	600	6 THK	02	AS PER CODE	SO	RF	-	ROOF MANHOLE WITH COVER	
N5	-	-	-	-	-	-	-	DELETED	
N9	75	40/5.1	01	300#	SO	RF	-	TEMPERATURE ELEMENT	
N10	200	40/8.1	01	300#	SO	RF	-	LEVEL TRANSMITTER (RADAR TYPE)	
N11A-B	300	40/9.2	02	150#	SO	RF	-	ROOF VENT	
N12	200	40/8.1	01	300#	SO	RF	-	LEVEL TRANSMITTER (RADAR TYPE)	
N13	80	80/7.6	01	300#	SO	RF	-	LEVEL SWITCH	
N14	200	40/8.1	01	150#	SO	RF	-	DIP HATCH WITH COVER	
N15	100	40/6.2	01	150#	SO	RF	-	SPARE	

GENERAL NOTES (INDICATIVE ONLY, TO BE CONFIRMED BY CONTRACTOR DURING DETAIL ENGINEERING):-

- ALL DIMENSIONS ARE IN MM UNLESS OTHERWISE SPECIFIED.
- ALL BUTT WELD SEAMS WITHOUT BACKING STRIP SHALL BE CHIPPED BACK TO SOUND METAL & REWELD.
- MANHOLE AND NOZZLE NECK 600NB AND ABOVE MAY BE FABRICATED FROM PLATE AND SHALL BE 100% RADIOGRAPHED.
- ALL NOZZLE SONB AND BELOW SHALL BE STIFFENED BY 2 NOS. 50x6THK FLAT 90° APART.
- ALL NOZZLE AND MANHOLE BOLTS SHALL STRADDLE THE NEUTRAL AXIS OF EQUIPMENT.
- THE NOZZLE ABOVE SONB SHALL BE PROVIDED WITH REINFORCEMENT PAD AS PER CODE.
- UNLESS OTHERWISE SPECIFIED, NOZZLE FLANGE SHALL CONFIRM TO ANSI/ASME B16, CLASS 150 FOR SIZES UPTO 600NB AND TO ASME B16.47 CLASS 150 FOR SIZES ABOVE 600NB.
- ALL COMPENSATION RINGS AND PADS SHALL BE PNEUMATICALLY TESTED WITH AIR AT 100 KPa(G) BY APPLYING SOAP SOLUTION ON OUTSIDE WELD. ALL REINFORCEMENT PADS SHOULD HAVE 6ø TELL-TALE ON HORIZONTAL CENTERLINE.
- PROJECTION OF SHELL NOZZLE ARE MENTIONED FROM OUTSIDE DIAMETER OF TANK / OUTER SURFACE OF ROOF OF TANK TO NOZZLE FLANGE FACE (i.e. GASKET SEATING FACE).
- DIMENSIONAL TOLERANCES SHALL BE IN ACCORDANCE WITH CLAUSE 7.5 OF API 650.
- VERTICAL JOINTS IN ADJACENT SHELL COURSES SHALL NOT BE IN ALIGNMENT BUT SHALL BE OFFSET FROM EACH OTHER BY 1/3RD OF THE PLATE LENGTH BUT IN NO CASE LESS THAN A DISTANCE OF 300 mm.
- GAUGE HATCH, TEMPERATURE ELEMENT & LEVEL TRANSMITTER SHOULD BE LOCATED AWAY FROM THE INLET AND OUTLET NOZZLE.
- ELECTRODES:- E-6013 : PLATES UP TO 12 THK.  
E-7018 : PLATES 12.5 THK AND ABOVE AND SHELL TO ANNULAR JOINT.
- THE TANKS SHALL BE MANUFACTURED, INSPECTED / TESTED, ERECTED & PAINTED AS PER LISTED SPECIFICATION
- EARTHING BOSS SHALL BE PROVIDED AS PER STD - BR/CR/236 & OISD 244.
- FABRICATOR HAS TO DESIGN, FABRICATE, SUPPLY, INSTALL ERECT AND COMMISSION THE TANK FROM POURER SYSTEM ALONG WITH FOAM TANK AND OTHER ACCESSORIES AND WATER SPRINKLER SYSTEM AS PER SPECIFICATION.
- EACH FOAM POURER NOZZLE TO BE PROVIDED WITH A PLATFORM OF SIZE 1.5M x 1.5M WITH RAILING AND A MONKEY LADDER TO ACCESS THE PLATFORM FROM THE ROOF TOP.
- VENT SHALL BE CONSIDERED AS PER API 2000 APPLICABLE FOR API 650 OR TANK SHALL BE EQUIPPED WITH WEAK ROOF TO SHELL ATTACHMENT (FRAGILE JOINT) AS PER API 650 REQUIREMENTS.
- TANK ACCESSORIES ARE INDICATIVE, TO BE VERIFIED & UPDATED BY CONTRACTOR DURING DETAIL ENGINEERING.
- WEIGHT INDICATED TO BE INDICATIVE ONLY. TO BE CONFIRMED BY CONTRACTOR DURING DETAIL ENGINEERING.
- OPERATING CONDITIONS INDICATED ARE PRELIMINARY AND TO BE VERIFIED & UPDATED BY CONTRACTOR DURING DETAIL ENGINEERING.
- THIS DRAWING IS INDICATIVE ONLY. CONTRACTOR/VENDOR TO DEVELOP TANK GA FABRICATION DRAWING DURING DETAIL ENGINEERING & SUBMIT FOR PMC/COMPANY APPROVAL.
- MOC INDICATED TO BE VERIFIED AND CONFIRMED BY CONTRACTOR DURING DETAIL ENGINEERING
- DRAWING & DRAWING DETAILS ARE PRELIMINARY AND TO BE VERIFIED & UPDATED BY CONTRACTOR DURING DETAIL ENGINEERING.
- RING BEAM DESIGN SHALL BE CHECKED FOR SLENDERNESS BY LSTK CONTRACTOR

MATERIAL SPECIFICATION (NOTE-23)

BOTTOM, SHELL, ROOF & REINFORCEMENT PLATE	A36/IS 2062 Gr B
SHELL/ROOF NOZZLE NECK UP TO 250 NB.	SA 106 Gr B
NOZZLE FLANGES	SA 105
MANHOLE NECK / FLANGE / COVER PLATE	A36/IS 2062 Gr B
SHELL NOZZLE NECK ABOVE 250 NB.	A36/IS 2062 Gr B
ROOF NOZZLE NECK ABOVE 250 NB.	A36/IS 2062 Gr B
BOLTING FOR NOZZLES	SA 193 Gr.B7/ 194 Gr.2H/AS PER PMS
BOLTING FOR STRUCTURES	SA 193 Gr.B7/ 194 Gr.2H/AS PER PMS
GASKETS	SS316 SPIRAL WOODEN GRAPHITE FILLED/ AS PER PMS
INTERNALS	A36/IS 2062 Gr B/A-106 Gr.B/SS304
STRUCTURES AND EXTERNALS (GUSSETS)	A36/IS 2062 Gr B
STAIRWAY PLATFORM AND STRUCTURAL	A36/A53/IS 2062 Gr A/B
HAND RAILING	A53/IS 2062 Gr A/B
GRATINGS	CS GALV
GAUGE WELL / STILL WELL/SLEEVE	SA 106 Gr.B
FITTINGS	SA 234 Gr.WPB
NAME PLATE / BRACKET	SS 304 /A36/ IS 2062 Gr B
EARTHING CONN.	AS PER ELECTRICAL SPECIFICATION
LEG PIPE SUPT. / SLEEVE	SA 106 Gr.B
ROOF DRAIN PIPE	SA 106 Gr.B
FOAM SYSTEM PIPES	AS PER PMS
ANCHOR BOLTS	A307 Gr.B/A563 Gr.A/IS 2062 Gr.B

ACCESSORIES (NOTE-19)

ACCESSORIES	SUPPLIED BY
ACCESS TO ROOF (SPIRAL STAIRWAY)	FABRICATOR
HANDRAIL AT TANK ROOF (ALL AROUND)	FABRICATOR
EARTHING BOSS WITH PIT	FABRICATOR
PLATFORM AT SHELL TOP AS PER STD	FABRICATOR
SAMPLING DEVICE (GAUGE HATCH)	FABRICATOR
LEVEL INDICATOR (ELECTRONIC)	FABRICATOR
TEMPERATURE INSTRUMENT	FABRICATOR
COOLING SYSTEM INCLUDING SPRAY NOZZLE	FABRICATOR
FOAM SYSTEM	FABRICATOR
GASKETS FOR SHELL & FIXED ROOF NOZZLES	FABRICATOR
TANK PRIMARY & SECONDARY SEAL	FABRICATOR
PRESSURE TRANSMITTER	FABRICATOR
LEVEL TRANSMITTER	FABRICATOR
JET MIXER	FABRICATOR

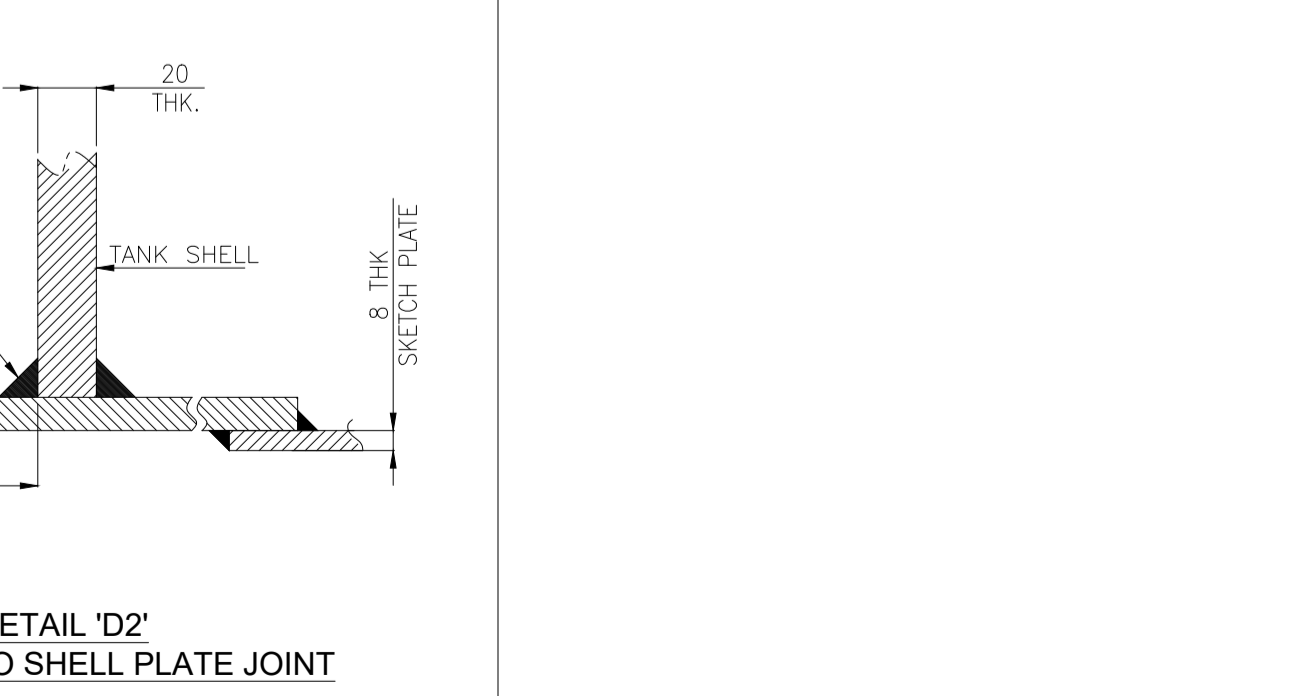
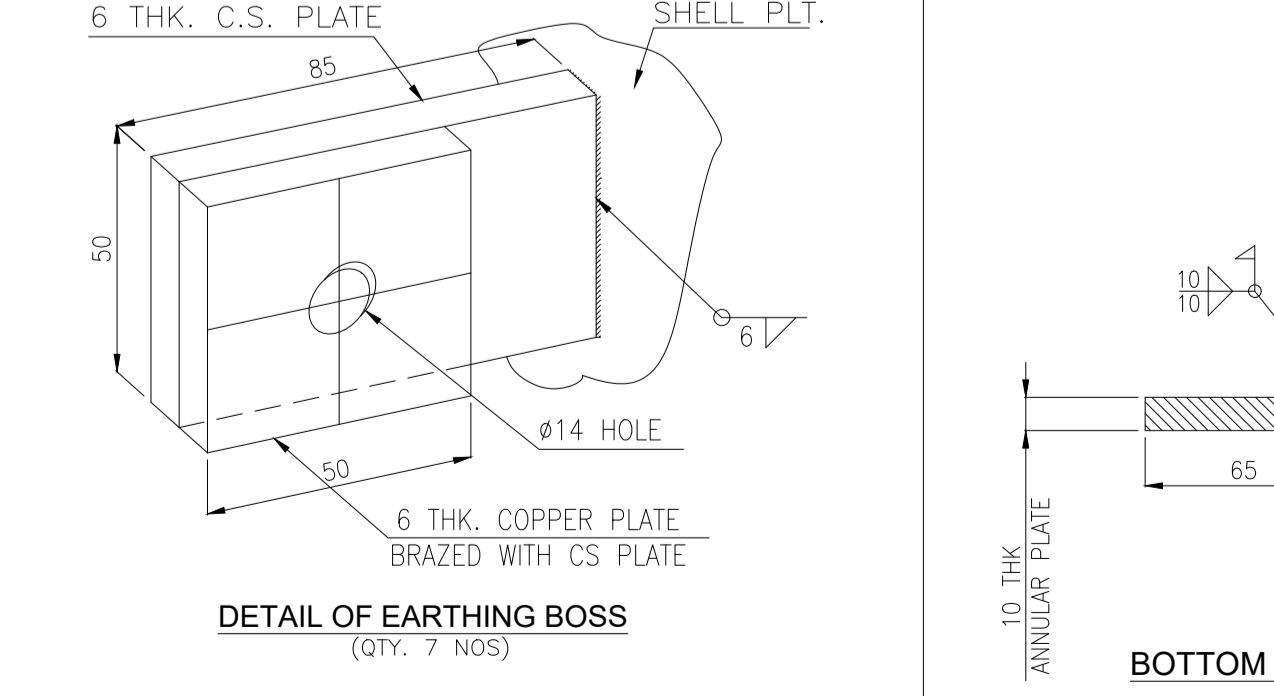
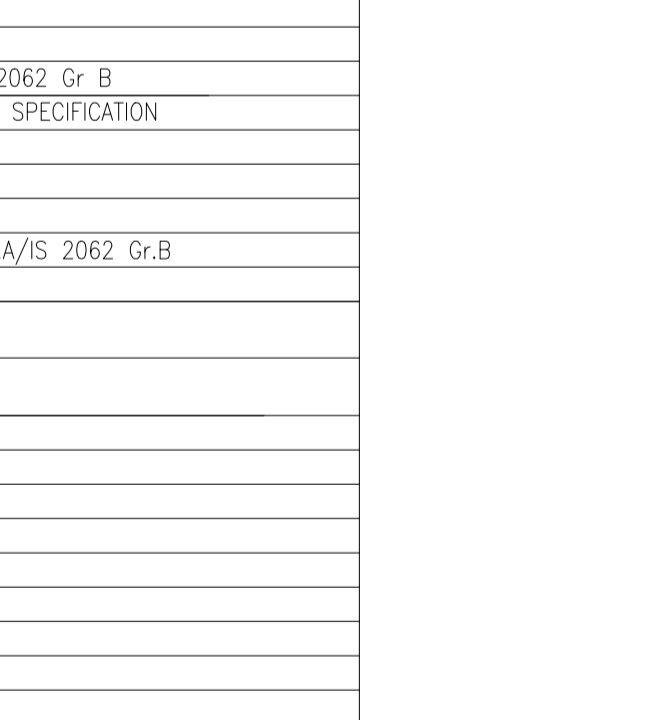
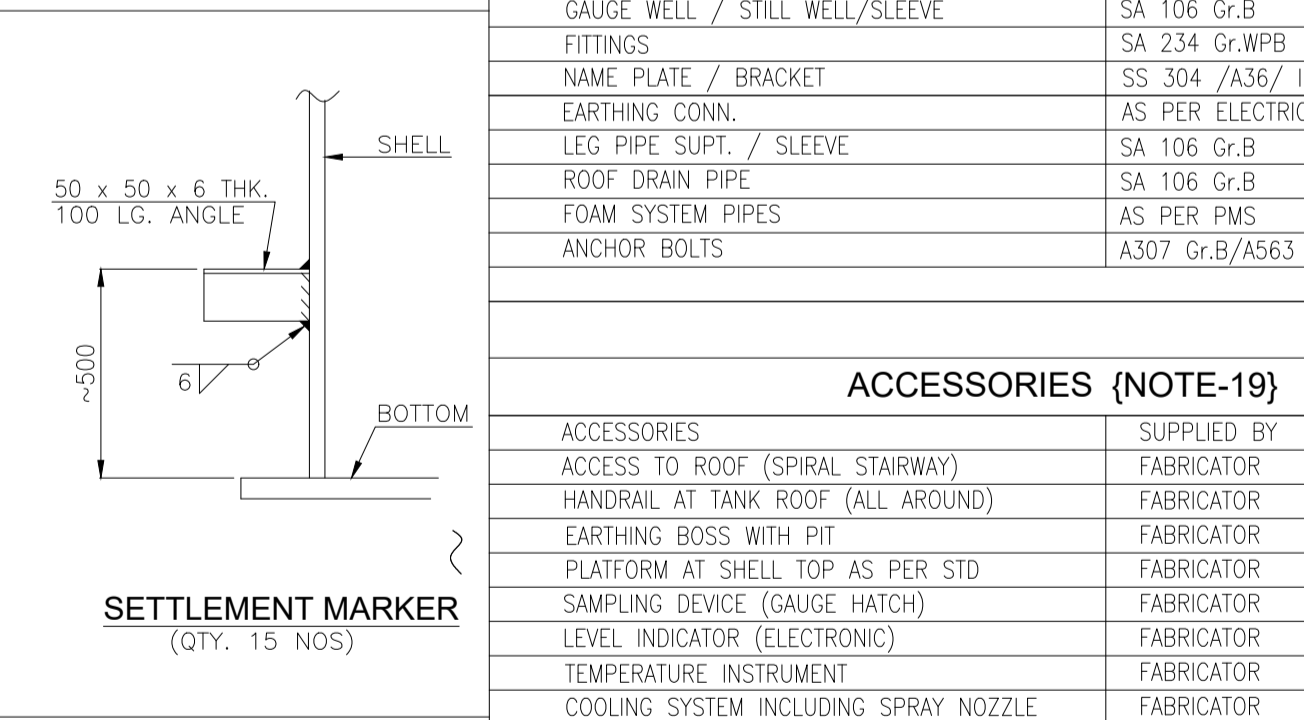
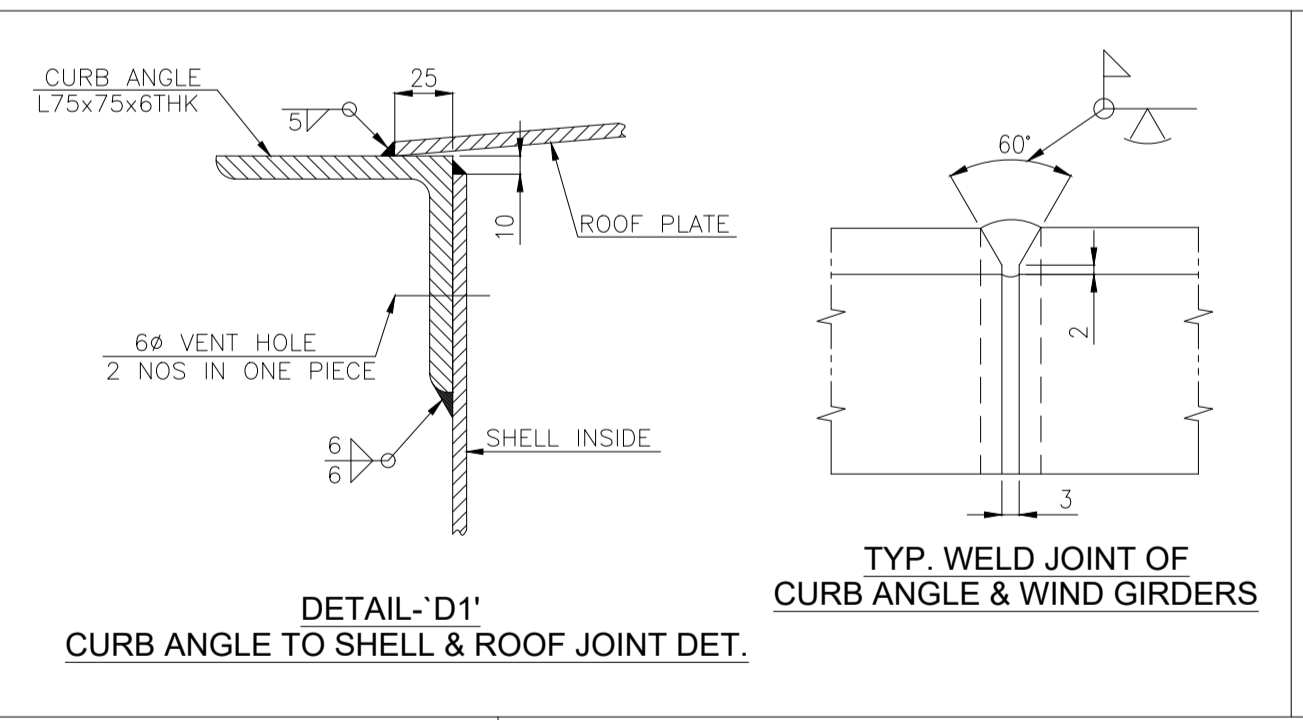
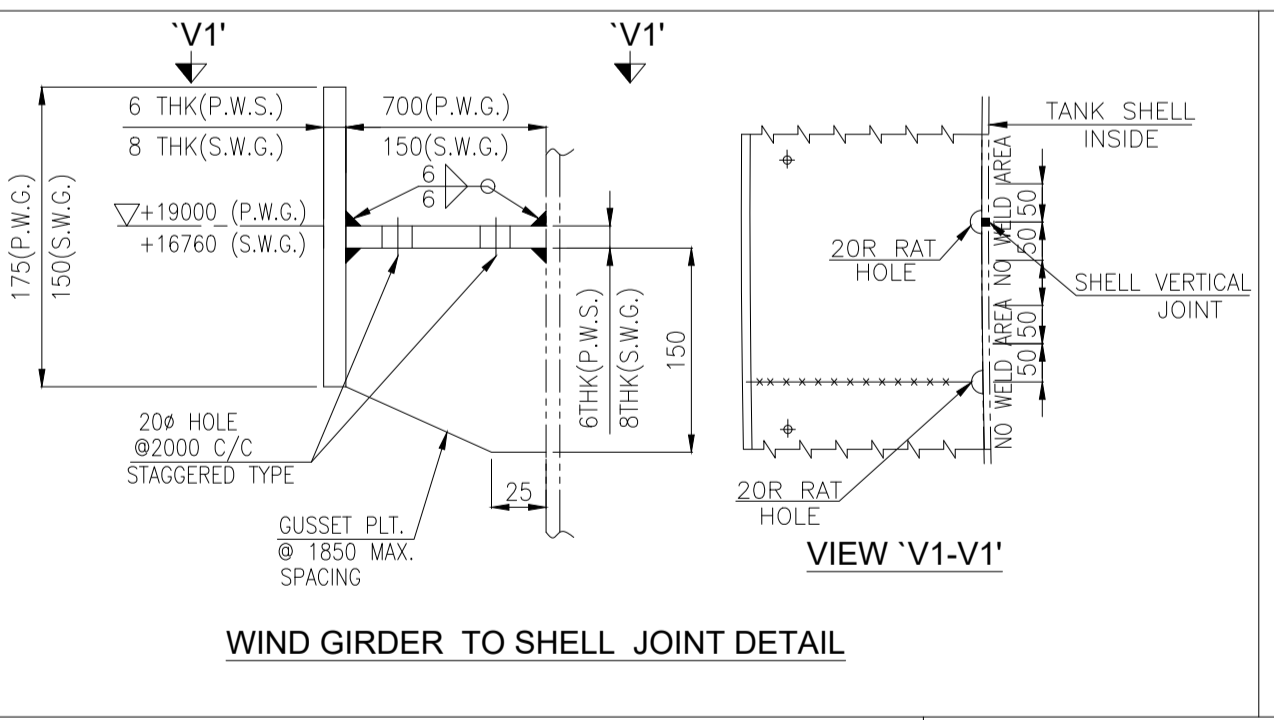
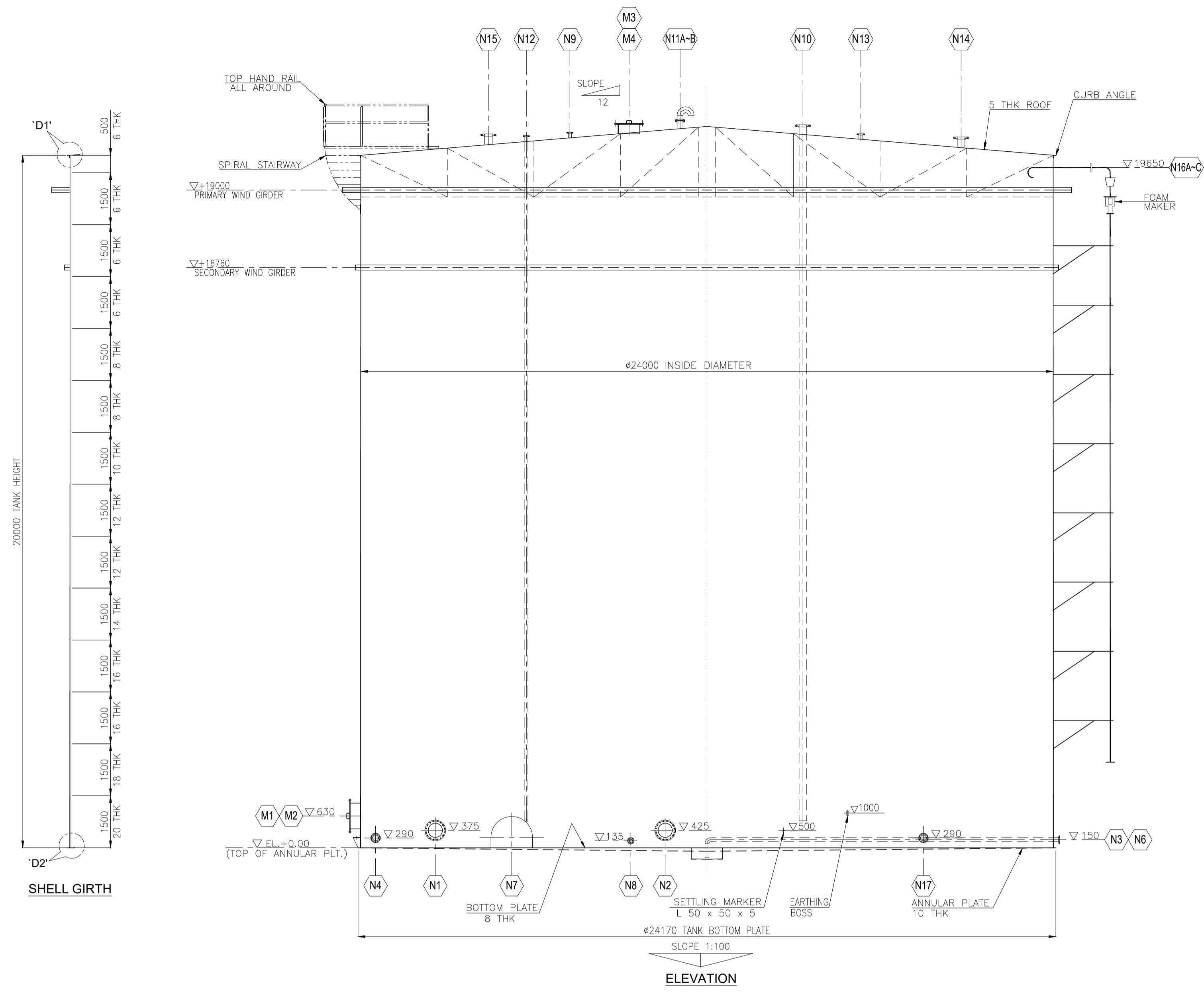

REV.	DATE	DESCRIPTION	DRWN	CHKD	APPRD	MRPL
1	05-MAY-21	RE-ISSUE FOR BID		YG	KSH	ASN
0	08-FEB-21	ISSUE FOR BID		YG	KSH	ASN
C1	21-DEC-20	ISSUE FOR REVIEW/COMMENTS		BN	YG	KSH

CLIENT: **ONGC MANGALORE REFINERY AND PETROCHEMICALS LIMITED**  
(A subsidiary of Oil & Natural Gas Corpn. Ltd - ONGC)

PROJECT: **CONSTRUCTION OF MARKETING TERMINAL PROJECT AT DEVANGONTHI, BANGALORE.**

PROJECT MANAGEMENT CONSULTANT: **nauvata ENGINEERING PVT. LTD.**

DRAWING TITLE: **GENERAL ARRANGEMENT DRAWING FOR HSD TANK (FB-A-02A/B/C) 24,000 MTR DIA. x 20,000 MTR HT.**

CLIENT TENDER No:	DRAWING No:	SHT NO.	REV	SCALE:
320000428	20005-GEN-M-DW-4102	1 OF 1	1	1:1

ALL RIGHTS RESERVED. NO PART OF THIS DRAWING MAY BE REPRODUCED / STORED IN RETRIEVAL SYSTEM OR TRANSMITTED IN ANY FORM OR BY ANY MEANS ELECTRONIC, MECHANICAL, PHOTOCOPYING, XEROXING OR OTHERWISE WITHOUT PRIOR PERMISSION FROM NAUVATA ENGINEERING LTD./MRPL

DRAWING NO.: 20005-PR-001



DESIGN DATA (NOTE-21)

DESIGN CODE	API-650, LATEST EDITION
STORED PRODUCT	ATF (CLASS-B)
SIZE OF TANK	INSIDE DIAMETER-24,000 M & HEIGHT-20,000 M
CAPACITY (PUMPABLE/LICENSE)	M <sup>3</sup> 8144/8300
NOS OF TANK	THREE
TYPE OF ROOF	CONE ROOF
CORROSION ALLOWANCE	3.0MM, OTHER-1ST SHELL COURSE & BOTTOM PLATE 1.5MM-OTHERS COURSES & ROOF PLATE
LIQUID DENSITY	KG/M <sup>3</sup> 775-840
MAX. DESIGN LIQUID LEVEL	M 20.0
DESIGN (POSITIVE) PRESSURE	MM WC ATMOSPHERIC + FULL OF LIQUID
OPERATING PRESSURE	MM WC ATMOSPHERIC
DESIGN TEMPERATURE	°C 80
OPERATING TEMPERATURE	°C 5-45
MDMT TEMPERATURE	°C 0
TEST PRESSURE	KG./CM <sup>2</sup> G FULL OF WATER
JOINT EFFICIENCY	AS PER CODE
RADIOGRAPHY	AS PER CODE
FLASH POINT	°C 38
WIND SPEED	M/Sec 33 (REFER SPEC OF TANKS-20005-GEN-M-SPE-4005)
WIND PRESSURE	KG/M <sup>2</sup> (REFER SPEC OF TANKS-20005-GEN-M-SPE-4005)
SEISMIC / ZONE	AS PER SPEC OF TANKS-20005-GEN-M-SPE-4005 (OUTSIDE SEISMIC ZONE)
PAINTING REFER PAINTING SPECIFICATION	
INSULATION / THK	NIL/-
FLOW RATE (IN/OUT)	M <sup>3</sup> /HR. 1050/288
INSPECTION	CLIENT / TPI
EMPTY WEIGHT	M.T. ~ 236.0
OPERATING WEIGHT	M.T. ~ 7324.9
HYDROTEST WT.	M.T. ~ 9279.2

NOZZLE SCHEDULE (INDICATIVE ONLY, TO BE CONFIRMED BY CONTRACTOR DURING DETAIL ENGINEERING):-

MARK	NOZZLE			FLANGE			PROJ.	SERVICE
	SIZE	SCH/THK	QTY.	RTG.	TYPE	FACE		
M1/2	600	8 THK	02	AS PER CODE			300	SHELL M/H WITH COVER
N1	350	19.0	01	300#	SO	RF	250	INLET
N2	250	80/15.0	01	300#	SO	RF	225	OUTLET (WITH FLOATING SUCTION)
N3	100	80/8.5	01	150#	SO	RF	175	WATER DRAW OFF
N4	150	80/10.9	01	150#	SO	RF	200	RECIRCULATION WITH JET MIXER
N6	50	160/8.7	01	150#	SO	RF	150	FAST FLUSHER
N7	900x1200	20 THK	01	AS PER CODE			-	CLEAN OUT DOOR
N8	50	160/8.7	01	300#	SO	RF	150	PRESSURE TRANSMITTER
N16A-C	250	80/15.9	03	150#	SO	RF	225	FOAM POURER WITH DEFLECTOR
N17	100	80/8.5	01	150#	SO	RF	175	PRODUCT DRAW OFF
N18	250	80/15.9	01	300#	SO	RF	225	OUTLET-2
M3/4	600	6 THK	02	AS PER CODE			-	ROOF MANHOLE WITH COVER
N5	-	-	-	-	-	-	-	DELETED
N9	75	40/5.1	01	300#	SO	RF	-	TEMPERATURE ELEMENT
N10	200	40/8.1	01	300#	SO	RF	-	LEVEL TRANSMITTER (RADAR TYPE)
N11A-B	250	40/8.1	02	150#	SO	RF	-	ROOF VENT
N12	200	40/8.1	01	300#	SO	RF	-	LEVEL TRANSMITTER (RADAR TYPE)
N13	80	80/7.6	01	300#	SO	RF	-	LEVEL SWITCH
N14	200	40/8.1	01	150#	SO	RF	-	DIP HATCH WITH COVER
N15	100	40/6.2	01	150#	SO	RF	-	SPARE

GENERAL NOTES (INDICATIVE ONLY, TO BE CONFIRMED BY CONTRACTOR DURING DETAIL ENGINEERING):-

- ALL DIMENSIONS ARE IN MM UNLESS OTHERWISE SPECIFIED.
- ALL BUTT WELD SEAMS WITHOUT BACKING STRIP SHALL BE CHIPPED BACK TO SOUND METAL & REWELD.
- MANHOLE AND NOZZLE NECK 600NB AND ABOVE MAY BE FABRICATED FROM PLATE AND SHALL BE 100% RADIOGRAPHED.
- ALL NOZZLE 50NB AND BELOW SHALL BE STIFFENED BY 2 NOS, 50x6THK FLAT 90° APART.
- ALL NOZZLE AND MANHOLE BOLTS SHALL STRADDLE THE NEUTRAL AXIS OF EQUIPMENT.
- THE NOZZLE ABOVE 50NB SHALL BE PROVIDED WITH REINFORCEMENT PAD AS PER CODE.
- UNLESS OTHERWISE SPECIFIED, NOZZLE FLANGE SHALL CONFIRM TO ANSI/ASME B16, CLASS 150 FOR SIZES UP TO 600NB AND TO ASME B16.47 CLASS 150 FOR SIZES ABOVE 600NB.
- ALL COMPENSATION RINGS AND PADS SHALL BE PNEUMATICALLY TESTED WITH AIR AT 100 KPa(G) BY APPLYING SOAP SOLUTION ON OUTSIDE WELD. ALL REINFORCEMENT PADS SHOULD HAVE 6Ø TELL-TALE ON HORIZONTAL CENTERLINE.
- PROJECTION OF SHELL NOZZLE ARE MENTIONED FROM OUTSIDE DIAMETER OF TANK / OUTER SURFACE OF ROOF OF TANK TO NOZZLE FLANGE FACE (i.e. GASKET SEATING FACE).
- DIMENSIONAL TOLERANCES SHALL BE IN ACCORDANCE WITH CLAUSE 7.5 OF API 650.
- VERTICAL JOINTS IN ADJACENT SHELL COURSES SHALL NOT BE IN ALIGNMENT BUT SHALL BE OFFSET FROM EACH OTHER BY 1/3RD OF THE PLATE LENGTH BUT IN NO CASE LESS THAN A DISTANCE OF 300 mm.
- GAUGE HATCH, TEMPERATURE ELEMENT & LEVEL TRANSMITTER SHOULD BE LOCATED AWAY FROM THE INLET AND OUTLET NOZZLE.
- ELECTRODES:- E-6013 : PLATES UP TO 12 THK.  
E-7018 : PLATES 12.5 THK AND ABOVE AND SHELL TO ANNULAR JOINT.
- THE TANKS SHALL BE MANUFACTURED, INSPECTED / TESTED, ERECTED & PAINTED AS PER LISTED SPECIFICATION.
- EARTHING BOSS SHALL BE PROVIDED AS PER STD - BR/CR/236 & OISD 244.
- FABRICATOR HAS TO DESIGN, FABRICATE, SUPPLY, INSTALL, ERECT AND COMMISSION THE FROM POURER SYSTEM ALONG WITH FOAM TANK AND OTHER ACCESSORIES AND WATER SPRINKLER SYSTEM AS PER SPECIFICATION.
- EACH FOAM POURER NOZZLE TO BE PROVIDED WITH A PLATFORM OF SIZE 1.5M x 1.5M WITH RAILING AND A MONKEY LADDER TO ACCESS THE PLATFORM FROM THE ROOF TOP.
- VENT SHALL BE CONSIDERED AS PER API 2000 APPLICABLE FOR API 650 OR TANK SHALL BE EQUIPPED WITH WEAK ROOF TO SHELL ATTACHMENT (FRAGILE JOINT) AS PER API 650 REQUIREMENTS.
- TANK ACCESSORIES ARE INDICATIVE, TO BE VERIFIED & UPDATED BY CONTRACTOR DURING DETAIL ENGINEERING.
- WEIGHT INDICATED TO BE INDICATIVE ONLY, TO BE CONFIRMED BY CONTRACTOR DURING DETAIL ENGINEERING.
- OPERATING CONDITIONS INDICATED ARE PRELIMINARY AND TO BE VERIFIED & UPDATED BY CONTRACTOR DURING DETAIL ENGINEERING.
- THIS DRAWING IS INDICATIVE ONLY, CONTRACTOR/VENDOR TO DEVELOP TANK GA FABRICATION DRAWING DURING DETAIL ENGINEERING & SUBMIT FOR PMC/COMPANY APPROVAL.
- MOC INDICATED TO BE VERIFIED AND CONFIRMED BY CONTRACTOR DURING DETAIL ENGINEERING.
- DRAWING & DRAWING DETAILS ARE PRELIMINARY AND TO BE VERIFIED & UPDATED BY CONTRACTOR DURING DETAIL ENGINEERING.
- RING BEAM DESIGN SHALL BE CHECKED FOR SLENDERNESS BY LSTK CONTRACTOR.

MATERIAL SPECIFICATION (NOTE-23)

BOTTOM, SHELL, ROOF & REINFORCEMENT PLATE	A36/IS 2062 Gr B
SHELL/ROOF NOZZLE NECK UP TO 250 NB.	SA 106 Gr.B
NOZZLE FLANGES	SA 105
MANHOLE NECK / FLANGE / COVER PLATE	A36/IS 2062 Gr B
SHELL NOZZLE NECK ABOVE 250 NB.	A36/IS 2062 Gr B
ROOF NOZZLE NECK ABOVE 250 NB.	A36/IS 2062 Gr B
BOLTING FOR NOZZLES	SA 193 Gr.B7 / 194 Gr.2H/AS PER PMS
BOLTING FOR STRUCTURES	SA 193 Gr.B7 / 194 Gr.2H/AS PER PMS
GASKETS	SS316 SPIRAL WOUND GRAPHITE FILLED/ AS PER PMS
INTERNALS	A36/IS 2062 Gr B/A106Gr.B/SS304
STRUCTURES AND EXTERNALS (CUSSETS)	A36/IS 2062 Gr B
STAIRWAY PLATFORM AND STRUCTURAL	A36/A53/IS 2062 Gr A/B
HAND RAILING	A53/IS 2062 Gr A/B
GRATINGS	CS GALV.
GAUGE WELL / STILL WELL/SLEEVE	SA 106 Gr.B
FITTINGS	SA 234 Gr.WPB
NAME PLATE / BRACKET	SS 304 /A36/ IS 2062 Gr B
EARTHING CONN.	AS PER ELECTRICAL SPECIFICATION
LEG PIPE SUPT. / SLEEVE	SA 106 Gr.B
ROOF DRAIN PIPE	SA 106 Gr.B
FOAM SYSTEM PIPES	AS PER PMS
ANCHOR BOLTS	A307 Gr.B/A563 Gr.A/IS 2062 Gr.B

ACCESSORIES (NOTE-19)

ACCESSORIES	SUPPLIED BY
ACCESS TO ROOF (SPIRAL STAIRWAY)	FABRICATOR
HANDRAIL AT TANK ROOF (ALL AROUND)	FABRICATOR
EARTHING BOSS WITH PIT	FABRICATOR
PLATFORM AT SHELL TOP AS PER STD	FABRICATOR
SAMPLING DEVICE (GAUGE HATCH)	FABRICATOR
LEVEL INDICATOR (ELECTRONIC)	FABRICATOR
TEMPERATURE INSTRUMENT	FABRICATOR
COOLING SYSTEM INCLUDING SPRAY NOZZLE	FABRICATOR
FOAM SYSTEM	FABRICATOR
GASKETS FOR SHELL & FIXED ROOF NOZZLES	FABRICATOR
TANK PRIMARY & SECONDARY SEAL	FABRICATOR
PRESSURE TRANSMITTER	FABRICATOR
LEVEL TRANSMITTER	FABRICATOR
JET MIXER	FABRICATOR

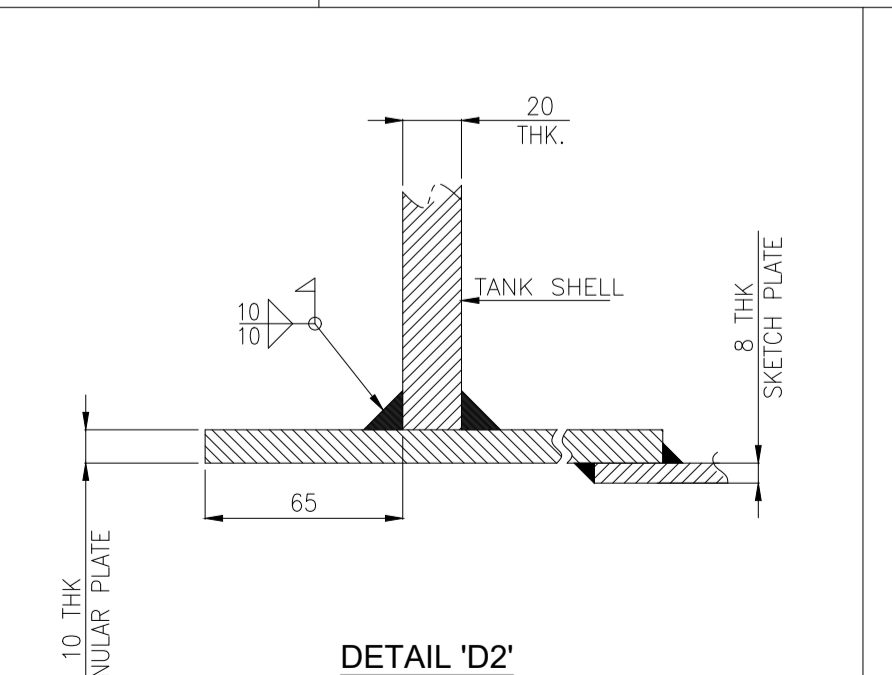
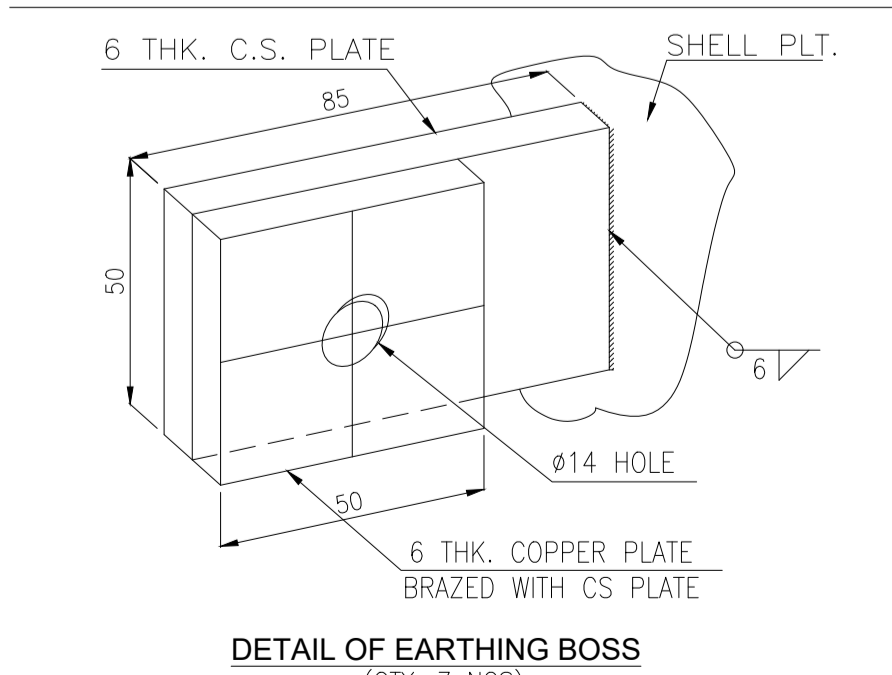
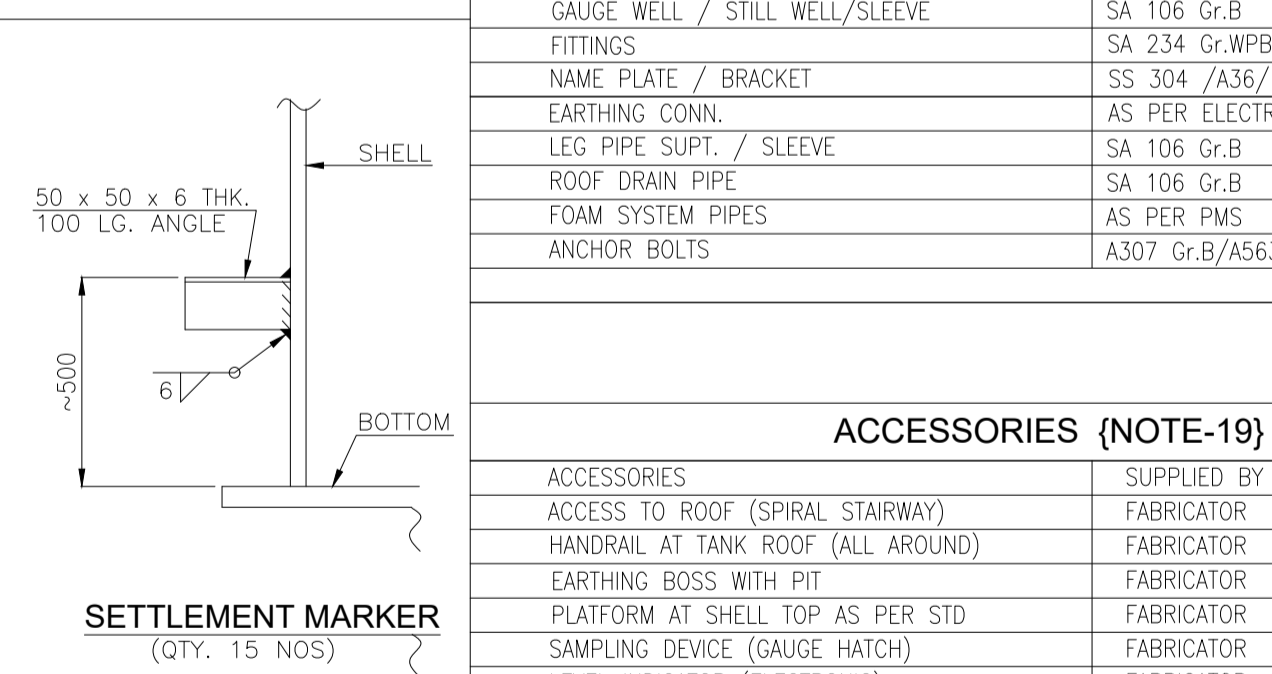
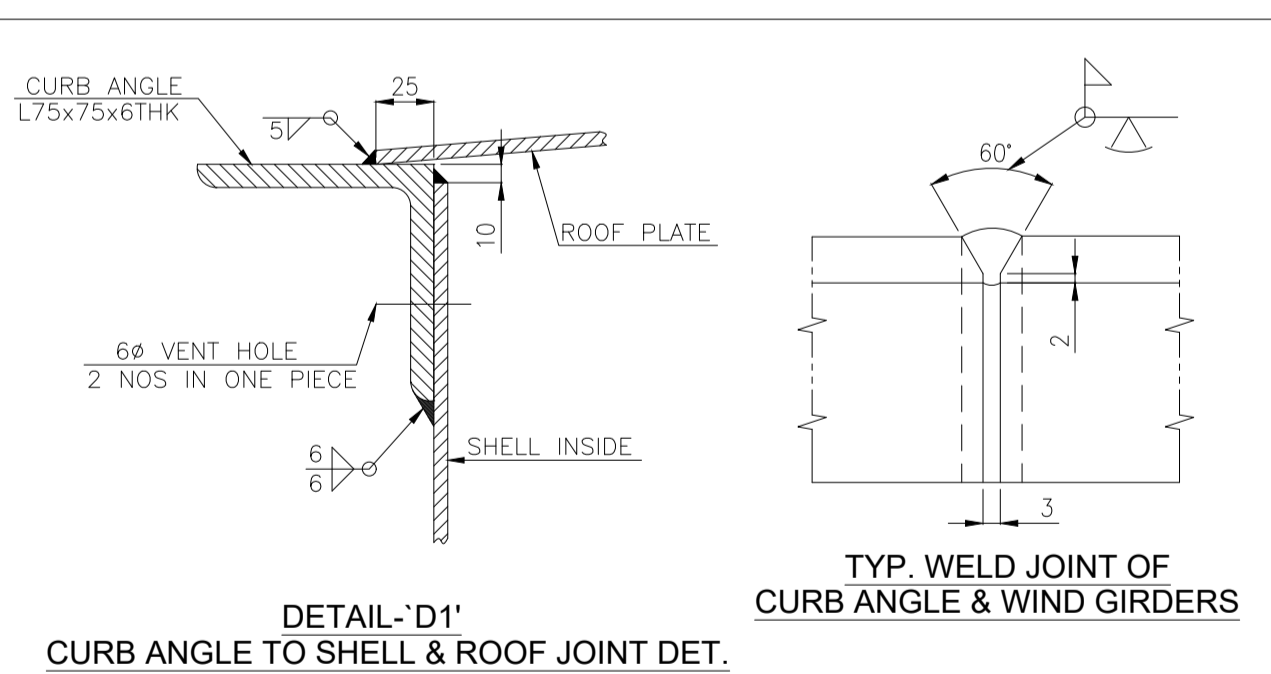
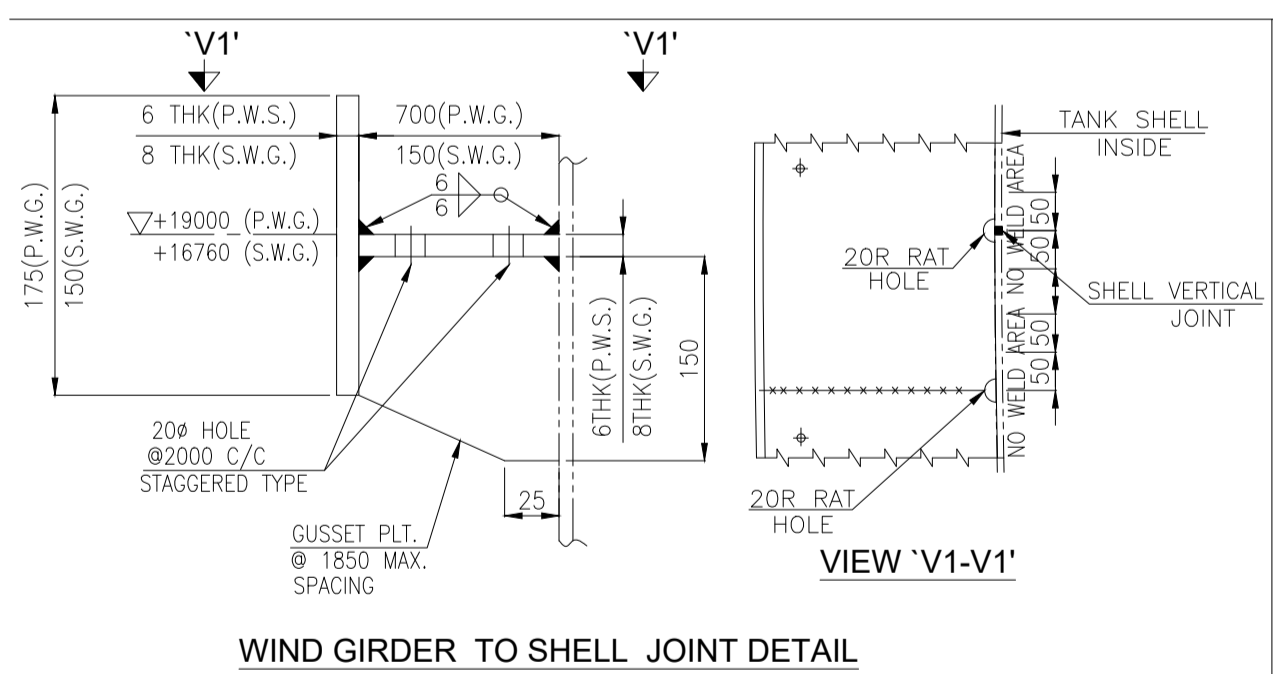
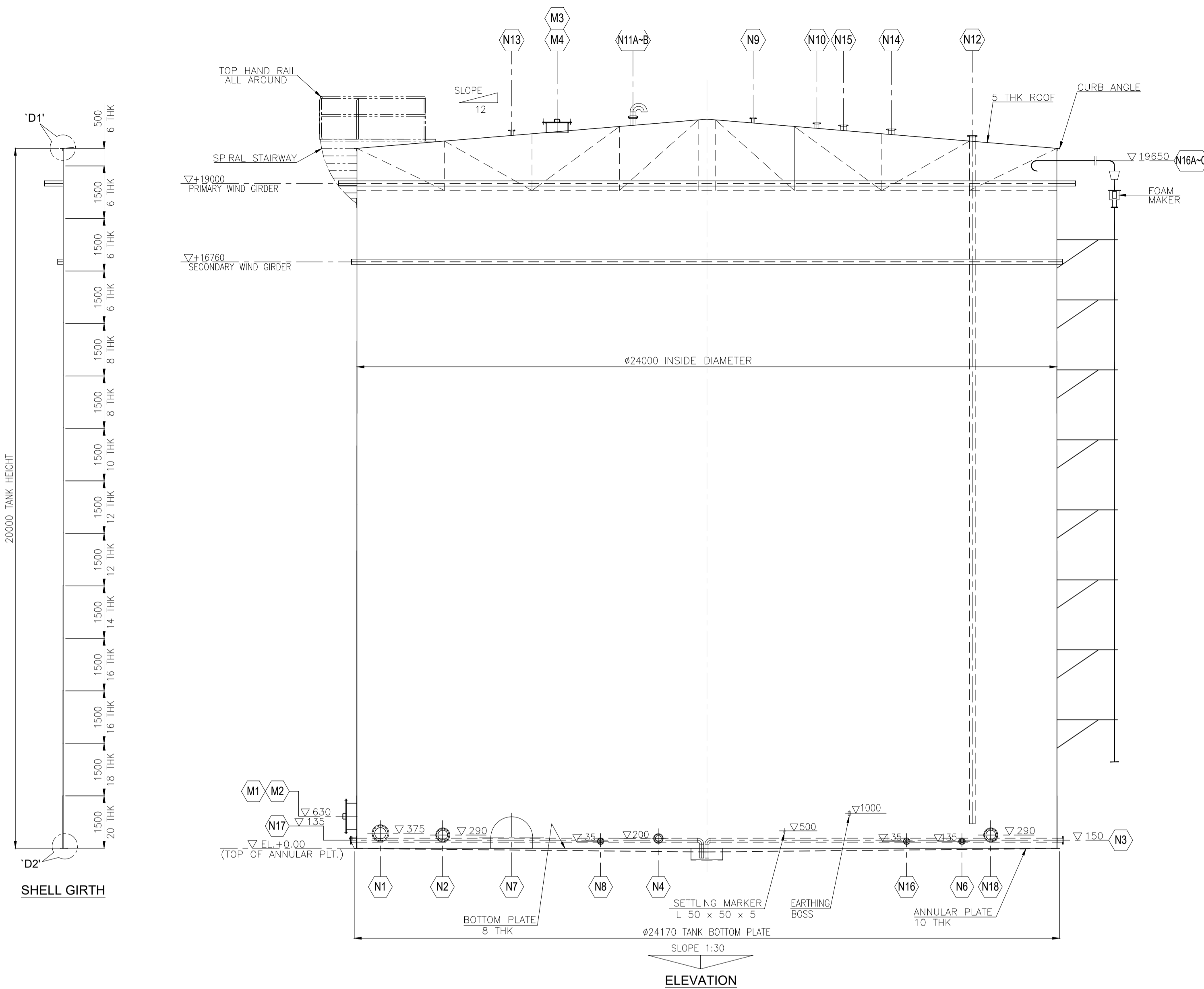

ALL RIGHTS RESERVED. NO PART OF THIS DRAWING MAY BE REPRODUCED / STORED IN RETRIEVAL SYSTEM OR TRANSMITTED IN ANY FORM OR BY ANY MEANS ELECTRONIC, MECHANICAL, PHOTOCOPYING, XEROXING OR OTHERWISE WITHOUT PRIOR PERMISSION FROM NAUVATA ENGINEERING LTD./MRPL

CLIENT: **ONGC MANGALORE REFINERY AND PETROCHEMICALS LIMITED**  
(A subsidiary of Oil & Natural Gas Corpn. Ltd - ONGC)

PROJECT: **CONSTRUCTION OF MARKETING TERMINAL PROJECT AT DEVANGONTHI, BANGALORE.**

PROJECT MANAGEMENT CONSULTANT: **NAUVATA ENGINEERING PVT. LTD.**

DRAWING TITLE: **GENERAL ARRANGEMENT DRAWING FOR ATF TANK (FB-A-03A/B/C) 24.000 MTR DIA. x 20.000 MTR HT.**

CLIENT TENDER No:	DRAWING No:	SHT NO.	REV	SCALE:
320000428	20005-GEN-M-DW-4103	1 OF 1	1	1:1

DRAWING NO.: 20005-PR-0001

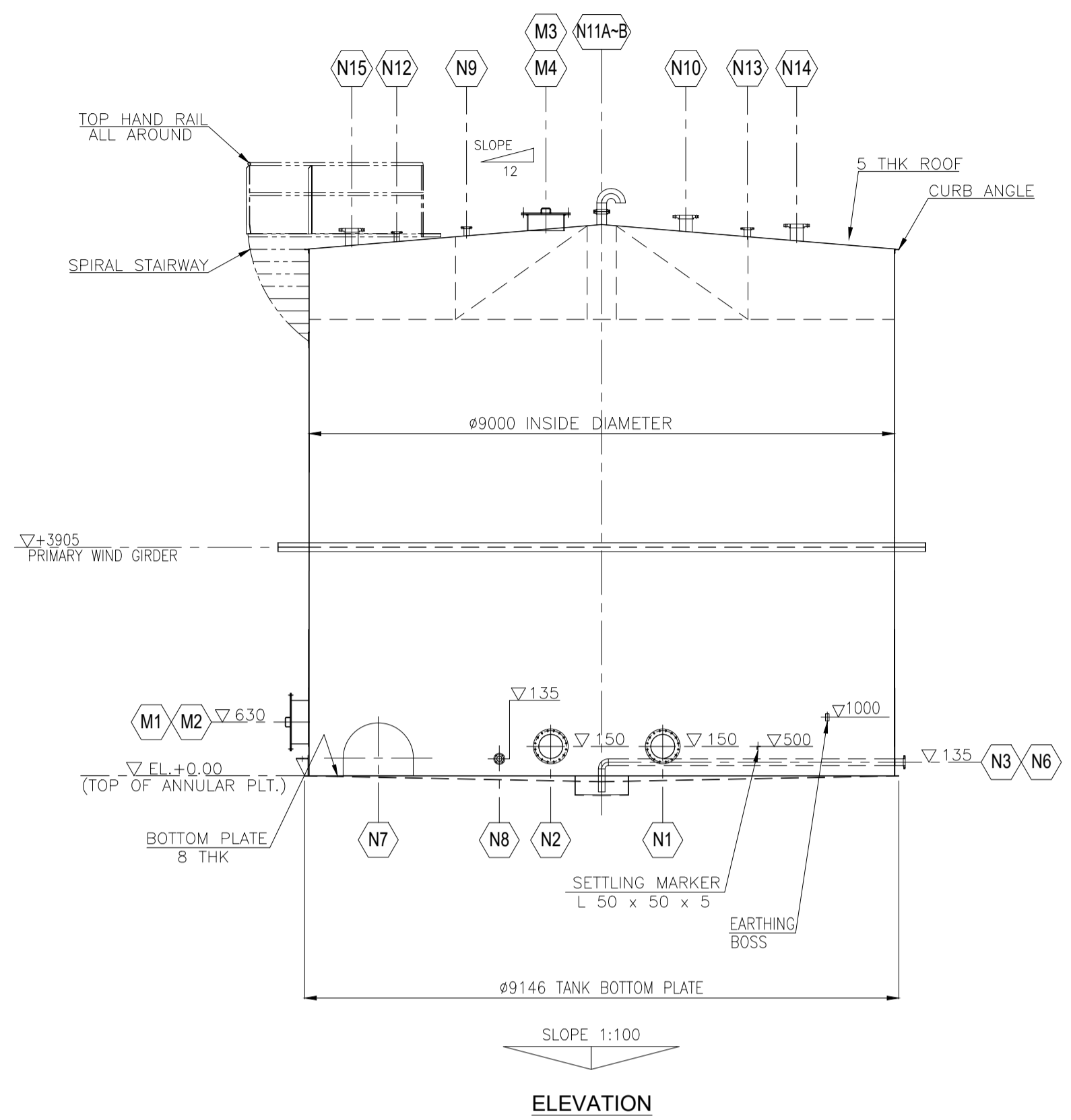
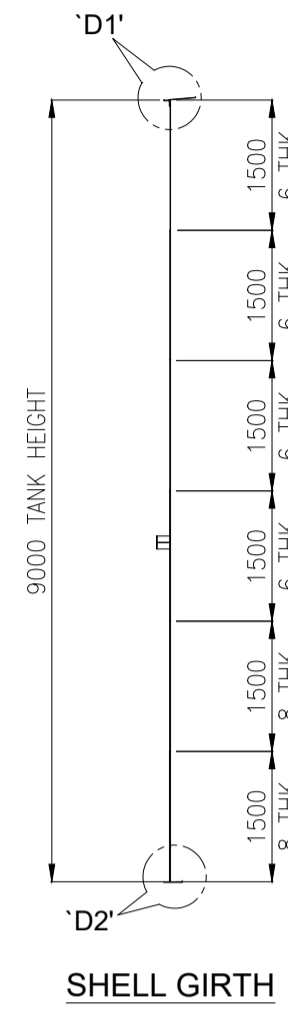

- GENERAL NOTES (INDICATIVE ONLY, TO BE CONFIRMED BY CONTRACTOR DURING DETAIL ENGINEERING):-**
- ALL DIMENSIONS ARE IN MM UNLESS OTHERWISE SPECIFIED.
  - ALL BUTT WELD SEAMS WITHOUT BACKING STRIP SHALL BE CHIPPED BACK TO SOUND METAL & REWELD.
  - MANHOLE AND NOZZLE NECK 600NB AND ABOVE MAY BE FABRICATED FROM PLATE AND SHALL BE 100% RADIOGRAPHED.
  - ALL NOZZLE 50NB AND BELOW SHALL BE STIFFENED BY 2 NOS, 50x6THK FLAT 90° APART.
  - ALL NOZZLE AND MANHOLE BOLTS SHALL STRADDLE THE NEUTRAL AXIS OF EQUIPMENT.
  - THE NOZZLE ABOVE 50NB SHALL BE PROVIDED WITH REINFORCEMENT PAD AS PER CODE.
  - UNLESS OTHERWISE SPECIFIED, NOZZLE FLANGE SHALL CONFIRM TO ANSI/ASME B16, CLASS 150 FOR SIZES UP TO 600NB AND TO ASME B16.47 CLASS 150 FOR SIZES ABOVE 600NB.
  - ALL COMPENSATION RINGS AND PADS SHALL BE PNEUMATICALLY TESTED WITH AIR AT 100 KPa(G) BY APPLYING SOAP SOLUTION ON OUTSIDE WELD. ALL REINFORCEMENT PADS SHOULD HAVE 6φ TELL-TALE ON HORIZONTAL CENTERLINE.
  - PROJECTION OF SHELL NOZZLE ARE MENTIONED FROM OUTSIDE DIAMETER OF TANK / OUTER SURFACE OF ROOF OF TANK TO NOZZLE FLANGE FACE (i.e. GASKET SEATING FACE).
  - DIMENSIONAL TOLERANCES SHALL BE IN ACCORDANCE WITH CLAUSE 7.5 OF API 650.
  - VERTICAL JOINTS IN ADJACENT SHELL COURSES SHALL NOT BE IN ALIGNMENT BUT SHALL BE OFFSET FROM EACH OTHER BY 1/3RD OF THE PLATE LENGTH BUT IN NO CASE LESS THAN A DISTANCE OF 300 mm.
  - GUAGE HATCH, TEMPERATURE ELEMENT & LEVEL TRANSMITTER SHOULD BE LOCATED AWAY FROM THE INLET AND OUTLET NOZZLE.
  - ELECTRODES:- E-6013 : PLATES UP TO 12 THK.  
E-7018 : PLATES 12.5 THK AND ABOVE AND SHELL TO ANNULAR JOINT.
  - THE TANKS SHALL BE MANUFACTURED, INSPECTED / TESTED, ERRECTED & PAINTED AS PER LISTED SPECIFICATION
  - EARTHING BOSS SHALL BE PROVIDED AS PER STD - BR/CR/236 & OISD 244.
  - FABRICATOR HAS TO DESIGN, FABRICATE, SUPPLY, INSTALL ERECT AND COMMISSION THE FROM POURER SYSTEM ALONG WITH FOAM TANK AND OTHER ACCESSORIES AND WATER SPRINKLER SYSTEM AS PER SPECIFICATION.
  - EACH FOAM POURER NOZZLE TO BE PROVIDED WITH A PLATFORM OF SIZE 1.5M x 1.5M WITH RAILING AND A MONKEY LADDER TO ACCESS THE PLATFORM FROM THE ROOF TOP.
  - VENT SHALL BE CONSIDERED AS PER API 2000 APPLICABLE FOR API 650 OR TANK SHALL BE EQUIPPED WITH WEAK ROOF TO SHELL ATTACHMENT (FRAGILE JOINT) AS PER API 650 REQUIREMENTS.
  - TANK ACCESSORIES ARE INDICATIVE, TO BE VERIFIED & UPDATED BY CONTRACTOR DURING DETAIL ENGINEERING.
  - WEIGHT INDICATED TO BE INDICATIVE ONLY, TO BE CONFIRMED BY CONTRACTOR DURING DETAIL ENGINEERING.
  - OPERATING CONDITIONS INDICATED ARE PRELIMINARY AND TO BE VERIFIED & UPDATED BY CONTRACTOR DURING DETAIL ENGINEERING.
  - THIS DRAWING IS INDICATIVE ONLY. CONTRACTOR/VENDOR TO DEVELOP TANK GA FABRICATION DRAWING DURING DETAIL ENGINEERING & SUBMIT FOR PMC/COMPANY APPROVAL.
  - MOC INDICATED TO BE VERIFIED AND CONFIRMED BY CONTRACTOR DURING DETAIL ENGINEERING
  - DRAWING & DRAWING DETAILS ARE PRELIMINARY AND TO BE VERIFIED & UPDATED BY CONTRACTOR DURING DETAIL ENGINEERING.
  - RING BEAM DESIGN SHALL BE CHECKED FOR SLENDERNESS BY LSTK CONTRACTOR.

**MATERIAL SPECIFICATION (NOTE-23)**

BOTTOM, SHELL, ROOF & REINFORCEMENT PLATE	A36/IS 2062 Gr B
SHELL/ROOF NOZZLE NECK UP TO 250 NB.	SA 106 Gr.B
NOZZLE FLANGES	SA 105
MANHOLE NECK / FLANGE / COVER PLATE	A36/IS 2062 Gr B
SHELL NOZZLE NECK ABOVE 250 NB.	A36/IS 2062 Gr B
ROOF NOZZLE NECK ABOVE 250 NB.	A36/IS 2062 Gr B
BOLTING FOR NOZZLES	SA 193 Gr.B7/ 194 Gr.2H/AS PER PMS
BOLTING FOR STRUCTURES	SA 193 Gr.B7/ 194 Gr.2H/AS PER PMS
GASKETS	SS316 SPIRAL WOUND GRAPHITE FILLED/ AS PER PMS
INTERNALS	A36/IS 2062 Gr B /A 106 Gr.B/SS304
STRUCTURES AND EXTERNALS (GUSSETS)	A36/IS 2062 Gr B
STAIRWAY PLATFORM AND STRUCTURAL	A36/A53/IS 2062 Gr A/B
HAND RAILING	A53/IS 2062 Gr B
GRATINGS	CS GALV.
GAUGE WELL / STILL WELL/SLEEVE	SA 106 Gr.B
FITTINGS	SA 234 Gr.WPB
NAME PLATE / BRACKET	SS 304 / A36/IS 2062 Gr B
EARTHING CONN.	AS PER ELECTRICAL SPECIFICATION
LEG PIPE SUPT. / SLEEVE	SA 106 Gr.B
ROOF DRAIN PIPE	SA 106 Gr.B
FOAM SYSTEM PIPES	AS PER PMS
ANCHOR BOLTS	A307 Gr.B/A563 Gr.A/IS 2062 Gr.B

**ACCESSORIES (NOTE-19)**

ACCESSORIES	SUPPLIED BY
ACCESS TO ROOF (SPIRAL STAIRWAY)	FABRICATOR
HANDRAIL AT TANK ROOF (ALL AROUND)	FABRICATOR
EARTHING BOSS WITH PIT	FABRICATOR
PLATFORM AT SHELL TOP AS PER STD	FABRICATOR
SAMPLING DEVICE (GAUGE HATCH)	FABRICATOR
LEVEL INDICATOR (ELECTRONIC)	FABRICATOR
TEMPERATURE INSTRUMENT	FABRICATOR
COOLING SYSTEM INCLUDING SPRAY NOZZLE	FABRICATOR
FOAM SYSTEM	FABRICATOR
GASKETS FOR SHELL & FIXED ROOF NOZZLES	FABRICATOR
TANK PRIMARY & SECONDARY SEAL	FABRICATOR
PRESSURE TRANSMITTER	FABRICATOR
LEVEL TRANSMITTER	FABRICATOR

DESIGN CODE	API-650, LATEST EDITION
STORED PRODUCT	ETHANOL (CLASS-A)
SIZE OF TANK	INSIDE DIAMETER-9,000 M & HEIGHT-9,000 M
CAPACITY (PUMPABLE/LICENSE)	M <sup>3</sup> 514/550
NOS OF TANK	TWO
TYPE OF ROOF	CONE ROOF
CORROSION ALLOWANCE	3.0MM, OTHER-1ST SHELL COURSE & BOTTOM PLATE 1.5MM-OTHERS COURSES & ROOF PLATE
LIQUID DENSITY	KG/M <sup>3</sup> 789 TO 790
MAX. DESIGN LIQUID LEVEL	M 9.0
DESIGN (POSITIVE) PRESSURE	MM WC ATMOSPHERIC + FULL OF LIQUID
OPERATING PRESSURE	MM WC ATMOSPHERIC
DESIGN TEMPERATURE	°C 80
OPERATING TEMPERATURE	°C 15-45
MDMT TEMPERATURE	°C 0
TEST PRESSURE	KG./CM <sup>2</sup> G FULL OF WATER
JOINT EFFICIENCY	AS PER CODE
RADIOGRAPHY	AS PER CODE
FLASH POINT	°C <10
WIND SPEED	M/Sec 33(REFER SPEC OF TANKS-20005-GEN-M-SPE-4005
WIND PRESSURE	KG/M <sup>2</sup> (REFER SPEC OF TANKS-20005-GEN-M-SPE-4005)
SEISMIC / ZONE	AS PER SPEC OF TANKS-20005-GEN-M-SPE-4005 (OUTSIDE SEISMIC ZONE)
PAINTING	REFER PAINTING SPECIFICATION
INSULATION / THK	NIL/-
FLOW RATE (IN/OUT)	M <sup>3</sup> /HR. 30/30
INSPECTION	CLIENT / TPI
EMPTY WEIGHT	M.T. ~ 25.0
OPERATING WEIGHT	M.T. ~ 483.5
HYDROTEST WT.	M.T. ~ 572.2

**NOZZLE SCHEDULE (INDICATIVE ONLY, TO BE CONFIRMED BY CONTRACTOR DURING DETAIL ENGINEERING):-**

MARK	NOZZLE SIZE	SCH/THK	QTY.	FLANGE			PROJ.	SERVICE
				RTG.	TYPE	FACE		
M1/2	600	8 THK	02	AS PER CODE		300	SHELL M/H WITH COVER	
N1	100	80/8.5	01	300#	SO	RF	175 INLET	
N2	100	80/8.5	01	300#	SO	RF	175 OUTLET	
N3	80	80/7.6	01	150#	SO	RF	175 WATER DRAW OFF	
N4	-	-	-	-	-	-	DELETED	
N6	80	80/7.6	01	150#	SO	RF	175 PRODUCT DRAW OFF	
N7	900x1200	8 THK	01	300#	SO	RF	- CLEAN OUT DOOR	
N8	50	160/8.7	01	300#	SO	RF	150 PRESSURE TRANSMITTER	
M3/4	600	6 THK	02	AS PER CODE			ROOF MANHOLE WITH COVER	
N9	75	40/5.1	01	300#	SO	RF	- TEMPERATURE ELEMENT	
N10	150	40/8.1	01	300#	SO	RF	- LEVEL TRANSMITTER (RADAR TYPE)	
N11A-B	200	40/6.2	02	150#	SO	RF	- ROOF VENT	
N12	200	40/8.1	01	300#	SO	RF	- LEVEL TRANSMITTER (RADAR TYPE)	
N13	80	80/7.6	01	150#	SO	RF	- LEVEL SWITCH	
N14	200	40/8.1	01	150#	SO	RF	- DIP HATCH WITH COVER	
N15	100	40/6.2	01	300#	SO	RF	- SPARE	

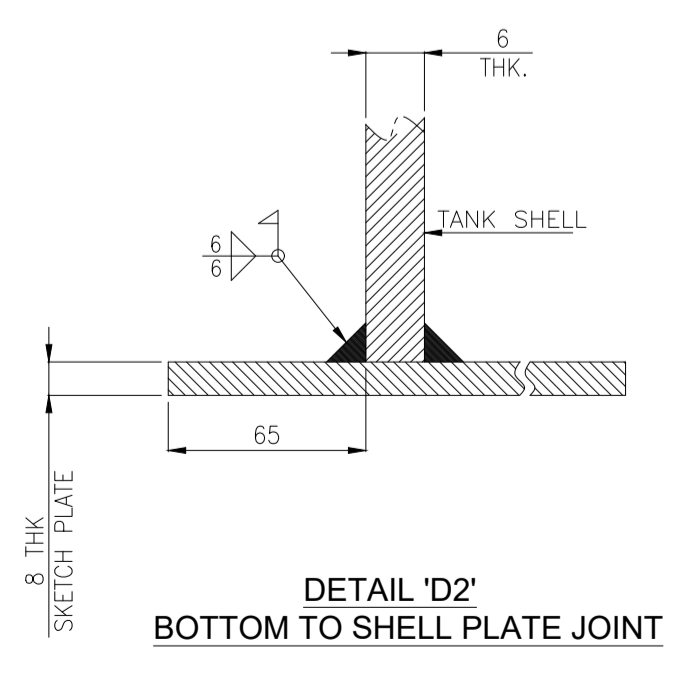
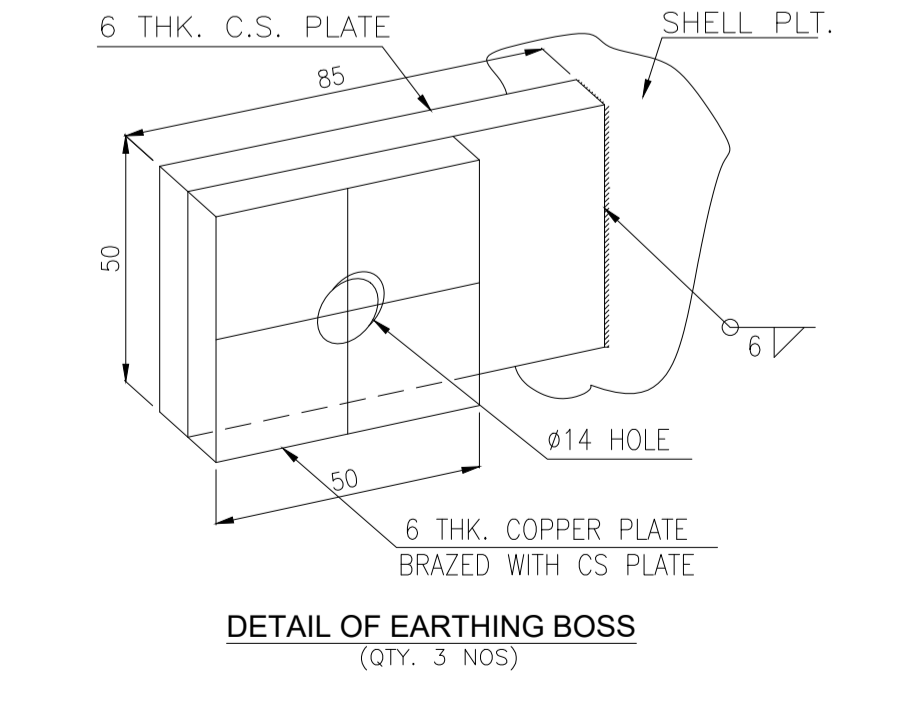
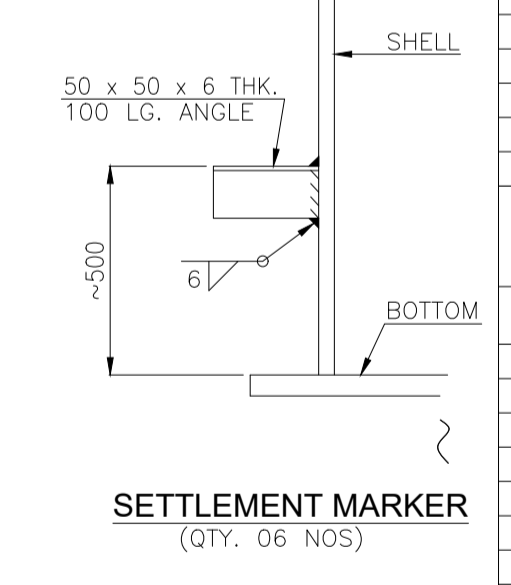
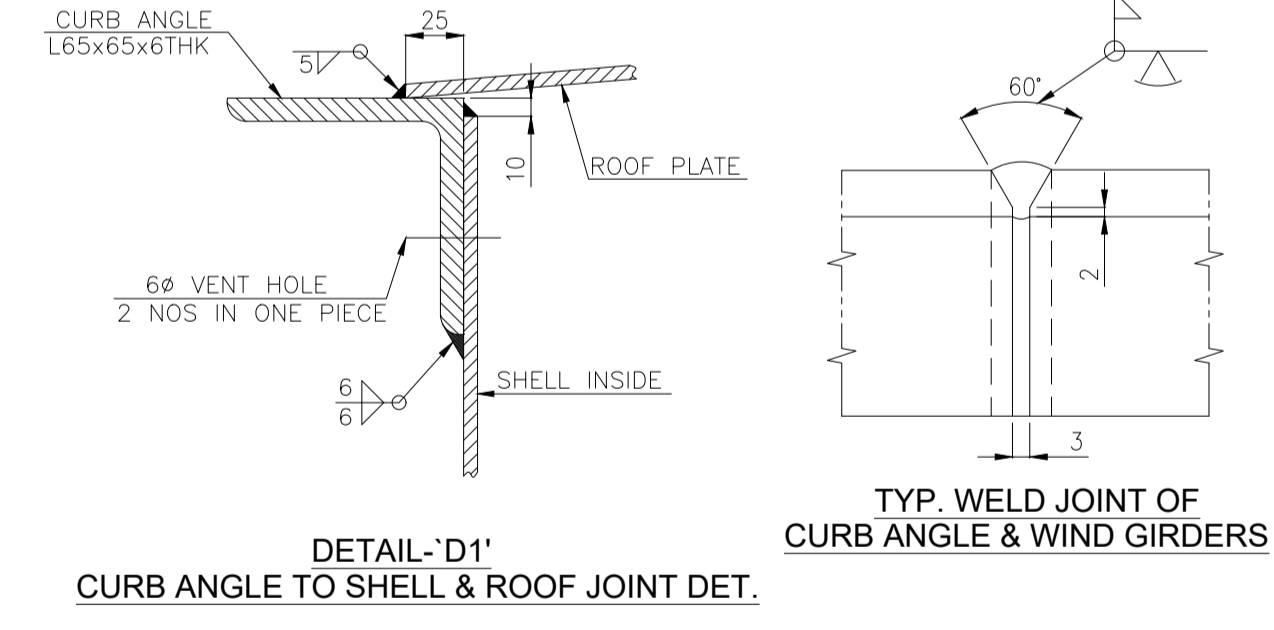
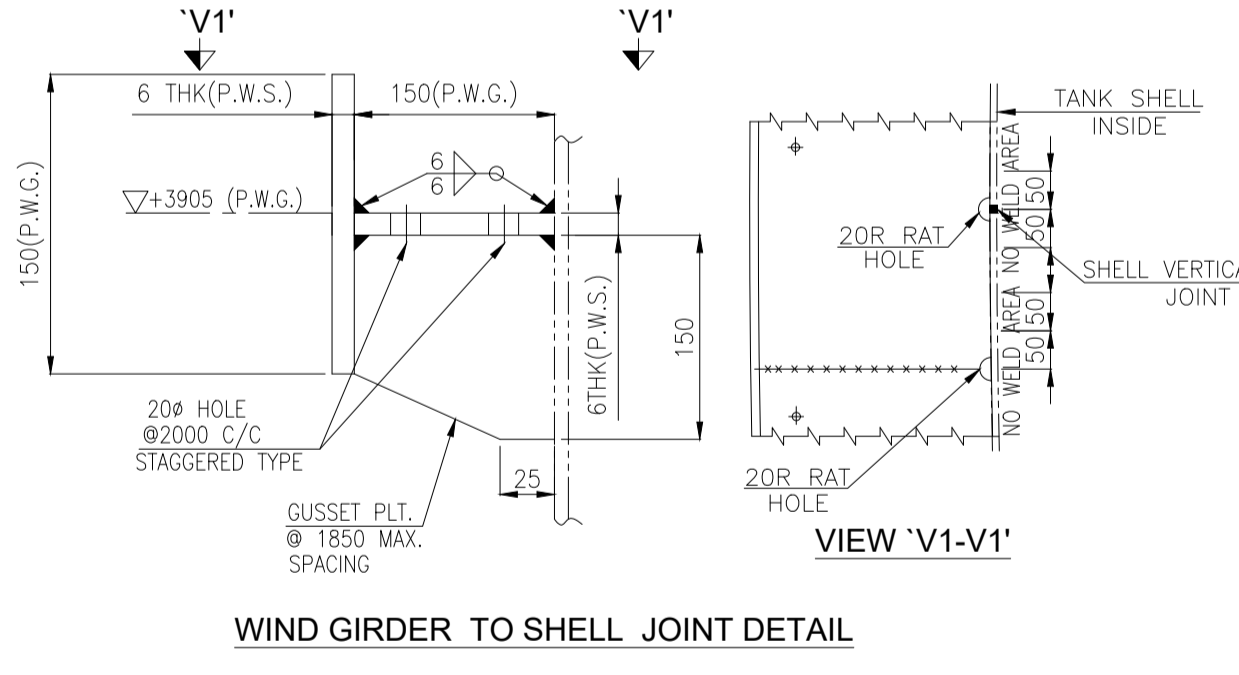

1	05-MAY-21	RE-ISSUE FOR BID	YG	KSH	ASN
0	08-FEB-21	ISSUE FOR BID	YG	KSH	ASN
C1	21-DEC-20	ISSUE FOR REVIEW/COMMENTS	BN	YG	KSH

CLIENT: **ONGC MANGALORE REFINERY AND PETROCHEMICALS LIMITED**  
(A subsidiary of Oil & Natural Gas Corpn. Ltd - ONGC)

PROJECT: **CONSTRUCTION OF MARKETING TERMINAL PROJECT AT DEVANGONTHI, BANGALORE.**

PROJECT MANAGEMENT CONSULTANT: **NAUVATA ENGINEERING PVT. LTD.**

DRAWING TITLE: **GENERAL ARRANGEMENT DRAWING FOR ETHANOL TANK (FB-A-06A/B) 9.000 MTR DIA. x 9.000 MTR HT.**

CLIENT TENDER No:	DRAWING No:	SHT NO.	REV	SCALE:
320000428	20005-GEN-M-DW-4104	1 OF 1	1	1:1

ALL RIGHTS RESERVED. NO PART OF THIS DRAWING MAY BE REPRODUCED / STORED IN RETRIEVAL SYSTEM OR TRANSMITTED IN ANY FORM OR BY ANYMEANS ELECTRONIC, MECHANICAL,PHOTOCOPYING, XEROXING OR OTHERWISE WITHOUT PRIOR PERMISSION FROM NAUVATA ENGINEERING LTD./MRPL



DESIGN DATA (NOTE-21)

DESIGN CODE	API-650 LATEST EDITION
STORED PRODUCT	INTERPHASE (CLASS-B)
SIZE OF TANK	INSIDE DIAMETER-10,000 M & HEIGHT-15,000 M
CAPACITY (PUMPABLE/LICENSE)	M <sup>3</sup> 1053/1100
NOS OF TANK	ONE
TYPE OF ROOF	CONE ROOF
CORROSION ALLOWANCE	3.0MM, OTHER-1ST SHELL COURSE & BOTTOM PLATE 1.5MM-OTHERS COURSES & ROOF PLATE
LIQUID DENSITY	KG/M <sup>3</sup> 820 TO 880
MAX. DESIGN LIQUID LEVEL	M 15.0
DESIGN (POSITIVE) PRESSURE	MM WC ATMOSPHERIC + FULL OF LIQUID
OPERATING PRESSURE	MM WC ATMOSPHERIC
DESIGN TEMPERATURE	°C 80
OPERATING TEMPERATURE	°C 5-45
MDMT TEMPERATURE	°C 0
TEST PRESSURE	KG./CM <sup>2</sup> G FULL OF WATER
JOINT EFFICIENCY	AS PER CODE
RADIOGRAPHY	AS PER CODE
FLASH POINT	°C 32-66
WIND SPEED	M/Sec 33(REFER SPEC OF TANKS-20005-GEN-M-SPE-4005
WIND PRESSURE	KG/M <sup>2</sup> (REFER SPEC OF TANKS-20005-GEN-M-SPE-4005)
SEISMIC / ZONE	AS PER SPEC OF TANKS-20005-GEN-M-SPE-4005
PAINTING	REFER PAINTING SPECIFICATION
INSULATION / THK	NIL/-
FLOW RATE (IN/OUT)	m <sup>3</sup> /hr. -/-
INSPECTION	CLIENT / TPI
EMPTY WEIGHT	M.T. ~ 40.0
OPERATING WEIGHT	M.T. ~ 994.9
HYDROTEST WT.	M.T. ~ 1177.5

NOZZLE SCHEDULE (INDICATIVE ONLY, TO BE CONFIRMED BY CONTRACTOR DURING DETAIL ENGINEERING):-

MARK	NOZZLE SIZE	SCH/THK	QTY.	FLANGE			PROJ.	SERVICE
				RTG.	TYPE	FACE		
M1/2	600	8 THK	02	AS PER CODE			300	SHELL M/H WITH COVER
N1	350	80/17.4	01	300#	SO	RF	250	INLET
N2	150	80/10.9	01	300#	SO	RF	200	OUTLET
N3	80	80/7.62	01	150#	SO	RF	175	WATER DRAW OFF
N4	100	80/8.56	01	150#	SO	RF	175	REDIRCULATION
N6	80	80/7.62	01	150#	SO	RF	175	PRODUCT DRAW OFF
N7	900x1200	8 THK	01	-	-	-	-	CLEAN OUT DOOR
N8	50	160/8.7	01	300#	SO	RF	150	PRESSURE TRANSMITTER
M3/4	600	6 THK	02	AS PER CODE			-	ROOF MANHOLE WITH COVER
N5	-	-	-	-	-	-	-	DELETED
N9	75	40/5.1	01	300#	SO	RF	-	TEMPERATURE ELEMENT
N10	200	40/8.1	01	300#	SO	RF	-	LEVEL TRANSMITTER (RADAR TYPE)
N11A-B	150	40/8.1	02	150#	SO	RF	-	ROOF VENT
N12	200	40/8.1	01	300#	SO	RF	-	LEVEL TRANSMITTER (RADAR TYPE)
N13	80	80/7.6	01	300#	SO	RF	-	LEVEL SWITCH
N14	200	40/8.1	01	150#	SO	RF	-	DIP HATCH WITH COVER
N15	100	40/6.2	01	150#	SO	RF	-	SPARE

GENERAL NOTES (INDICATIVE ONLY, TO BE CONFIRMED BY CONTRACTOR DURING DETAIL ENGINEERING):-

- ALL DIMENSIONS ARE IN MM UNLESS OTHERWISE SPECIFIED.
- ALL BUTT WELD SEAMS WITHOUT BACKING STRIP SHALL BE CHIPPED BACK TO SOUND METAL & REWELD.
- MANHOLE AND NOZZLE NECK 600NB AND ABOVE MAY BE FABRICATED FROM PLATE AND SHALL BE 100% RADIOGRAPHED.
- ALL NOZZLE 50NB AND BELOW SHALL BE STIFFENED BY 2 NOS, 50x6THK FLAT 90° APART.
- ALL NOZZLE AND MANHOLE BOLTS SHALL STRADDLE THE NEUTRAL AXIS OF EQUIPMENT.
- THE NOZZLE ABOVE 50NB SHALL BE PROVIDED WITH REINFORCEMENT PAD AS PER CODE.
- UNLESS OTHERWISE SPECIFIED, NOZZLE FLANGE SHALL CONFIRM TO ANSI/ASME B16, CLASS 150 FOR SIZES UP TO 600NB AND TO ASME B16.47 CLASS 150 FOR SIZES ABOVE 600NB.
- ALL COMPENSATION RINGS AND PADS SHALL BE PNEUMATICALLY TESTED WITH AIR AT 100 KPa(G) BY APPLYING SOAP SOLUTION ON OUTSIDE WELD. ALL REINFORCEMENT PADS SHOULD HAVE 6ø TELL-TALE ON HORIZONTAL CENTERLINE.
- PROJECTION OF SHELL NOZZLE ARE MENTIONED FROM OUTSIDE DIAMETER OF TANK /OUTER SURFACE OF ROOF OF TANK TO NOZZLE FLANGE FACE(i.e. GASKET SEATING FACE)
- DIMENSIONAL TOLERANCES SHALL BE IN ACCORDANCE WITH CLAUSE 7.5 OF API 650.
- VERTICAL JOINTS IN ADJACENT SHELL COURSES SHALL NOT BE IN ALIGNMENT BUT SHALL BE OFFSET FROM EACH OTHER BY 1/3RD OF THE PLATE LENGTH BUT IN NO CASE LESS THAN A DISTANCE OF 300 mm.
- GAUGE HATCH, TEMPERATURE ELEMENT & LEVEL TRANSMITTER SHOULD BE LOCATED AWAY FROM THE INLET AND OUTLET NOZZLE.
- ELECTRODES:- E-6013 : PLATES UP TO 12 THK.  
E-7018 : PLATES 12.5 THK AND ABOVE AND SHELL TO ANNULAR JOINT. AS PER LISTED SPECIFICATION
- THE TANKS SHALL BE MANUFACTURED, INSPECTED / TESTED, ERECTED & PAINTED AS PER LISTED SPECIFICATION
- EARTHING BOSS SHALL BE PROVIDED AS PER STD - BR/CR/236 & OISD 244.
- FABRICATOR HAS TO DESIGN, FABRICATE, SUPPLY, INSTALL ERECT AND COMMISSION THE FROM POURER SYSTEM ALONG WITH FOAM TANK AND OTHER ACCESSORIES AND WATER SPRINKLER SYSTEM AS PER SPECIFICATION.
- EACH FOAM POURER NOZZLE TO BE PROVIDED WITH A PLATFORM OF SIZE 1.5M x 1.5M WITH RAILING AND A MONKEY LADDER TO ACCESS THE PLATFORM FROM THE ROOF TOP
- VENT SHALL BE CONSIDERED AS PER API 2000 APPLICABLE FOR API 650 OR TANK SHALL BE EQUIPPED WITH WEAK ROOF TO SHELL ATTACHMENT(FRAGILE JOINT) AS PER API 650 REQUIREMENTS.
- TANK ACCESSORIES ARE INDICATIVE, TO BE VERIFIED & UPDATED BY CONTRACTOR DURING DETAIL ENGINEERING.
- WEIGHT INDICATED TO BE INDICATIVE ONLY. TO BE CONFIRMED BY CONTRACTOR DURING DETAIL ENGINEERING.
- OPERATING CONDITIONS INDICATED ARE PRELIMINARY AND TO BE VERIFIED & UPDATED BY CONTRACTOR DURING DETAIL ENGINEERING.
- THIS DRAWING IS INDICATIVE ONLY. CONTRACTOR/VENDOR TO DEVELOP TANK GA FABRICATION DRAWING DURING DETAIL ENGINEERING & SUBMIT FOR PMC/COMPANY APPROVAL.
- MOC INDICATED TO BE VERIFIED AND CONFIRMED BY CONTRACTOR DURING DETAIL ENGINEERING
- DRAWING & DRAWING DETAILS ARE PRELIMINARY AND TO BE VERIFIED & UPDATED BY CONTRACTOR DURING DETAIL ENGINEERING.
- RING BEAM DESIGN SHALL BE CHECKED FOR SLENDERNESS BY LSTK CONTRACTOR.

MATERIAL SPECIFICATION (NOTE-23)

BOTTOM, SHELL, ROOF & REINFORCEMENT PLATE	A36/IS 2062 Gr B
SHELL/ROOF NOZZLE NECK UP TO 250 NB.	SA 106 Gr.B
NOZZLE FLANGES	SA 105
MANHOLE NECK / FLANGE / COVER PLATE	A36/IS 2062 Gr B
SHELL NOZZLE NECK ABOVE 250 NB.	A36/IS 2062 Gr B
ROOF NOZZLE NECK ABOVE 250 NB.	A36/IS 2062 Gr B
BOLTING FOR NOZZLES	SA 193 Gr.B7/ 194 Gr.2H/AS PER PMS
BOLTING FOR STRUCTURES	SA 193 Gr.B7/ 194 Gr.2H/AS PER PMS
GASKETS	SS316 SPIRAL WOUND GRAPHITE FILLED/ AS PER PMS
INTERNALS	A36/IS 2062 Gr B /A 106 Gr.B/SS304
STRUCTURES AND EXTERNALS (GUSSETS)	A36/IS 2062 Gr B
STAIRWAY PLATFORM AND STRUCTURAL	A36/A53/IS 2062 Gr A/B
HAND RAILING	A53/IS 2062 Gr A/B
GRATINGS	CS GALV.
GAUGE WELL / STILL WELL/SLEEVE	SA 106 Gr.B
FITTINGS	SA 234 Gr.WPB
NAME PLATE / BRACKET	SS 304 / IS 2062 Gr B
EARTHING CONN.	AS PER ELECTRICAL SPECIFICATION
LEG PIPE SUPT. / SLEEVE	SA 106 Gr.B
ROOF DRAIN PIPE	SA 106 Gr.B
FOAM SYSTEM PIPES	AS PER PMS
ANCHOR BOLTS	A307 Gr.B/A563 Gr.A/IS 2062 Gr.B

ACCESSORIES (NOTE-19)

ACCESSORIES	SUPPLIED BY
ACCESS TO ROOF (SPIRAL STAIRWAY)	FABRICATOR
HANDRAIL AT TANK ROOF (ALL AROUND)	FABRICATOR
EARTHING BOSS WITH PIT	FABRICATOR
PLATFORM AT SHELL TOP AS PER STD	FABRICATOR
SAMPLING DEVICE (GAUGE HATCH)	FABRICATOR
LEVEL INDICATOR (ELECTRONIC)	FABRICATOR
TEMPERATURE INSTRUMENT	FABRICATOR
COOLING SYSTEM INCLUDING SPRAY NOZZLE	FABRICATOR
FOAM SYSTEM	FABRICATOR
GASKETS FOR SHELL & FIXED ROOF NOZZLES	FABRICATOR
TANK PRIMARY & SECONDARY SEAL	FABRICATOR
PRESSURE TRANSMITTER	FABRICATOR
LEVEL TRANSMITTER	FABRICATOR

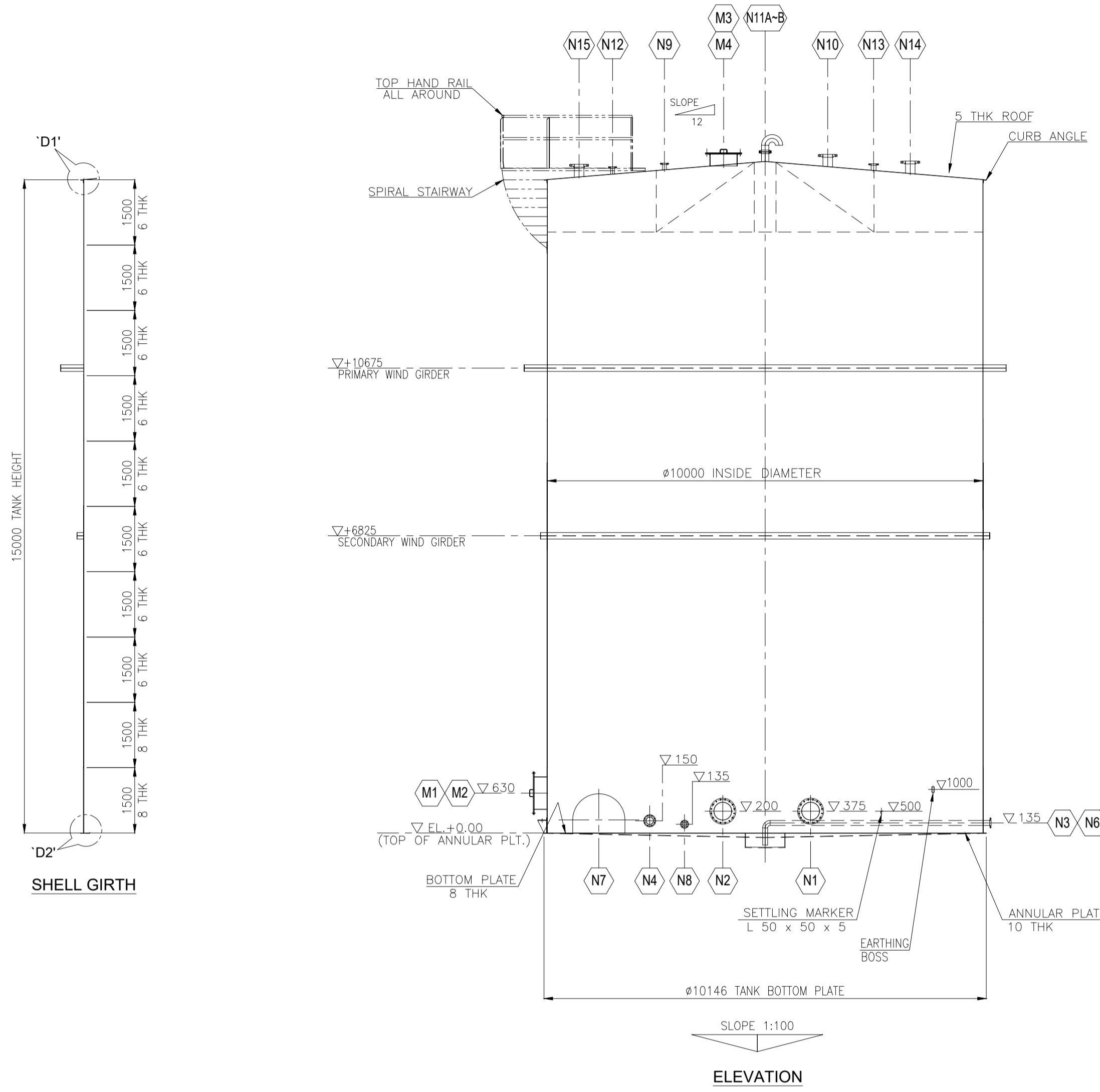

SHELL GIRTH

ELEVATION

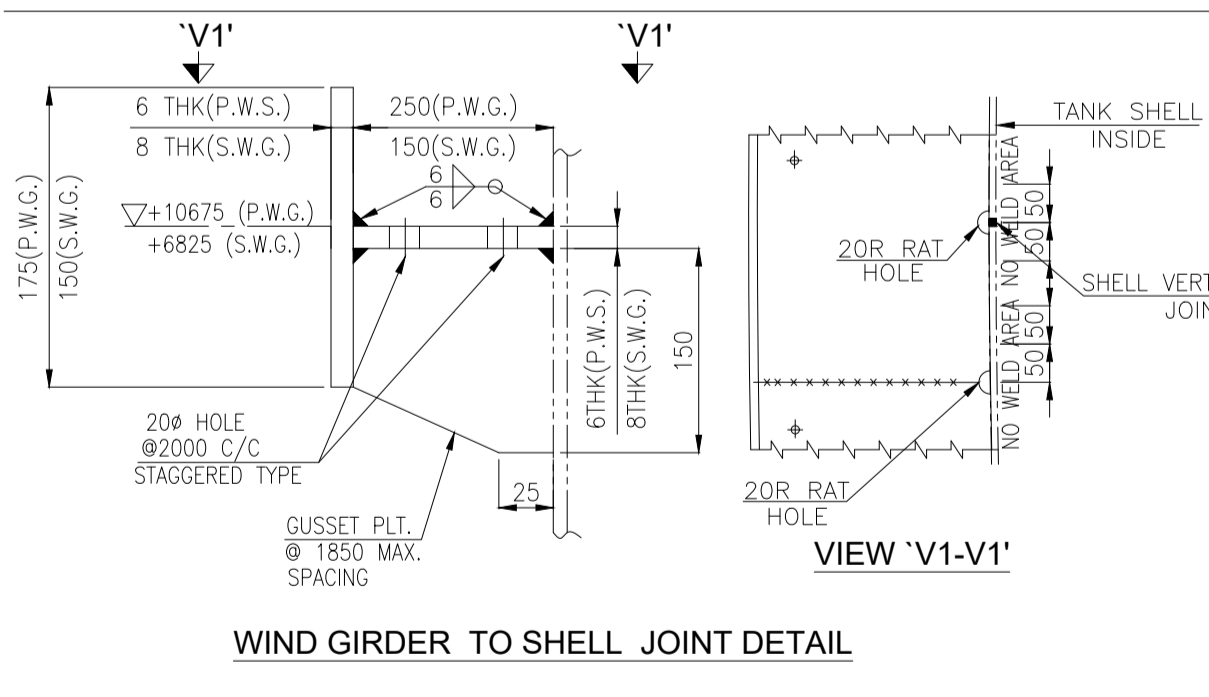

WIND GIRDER TO SHELL JOINT DETAIL

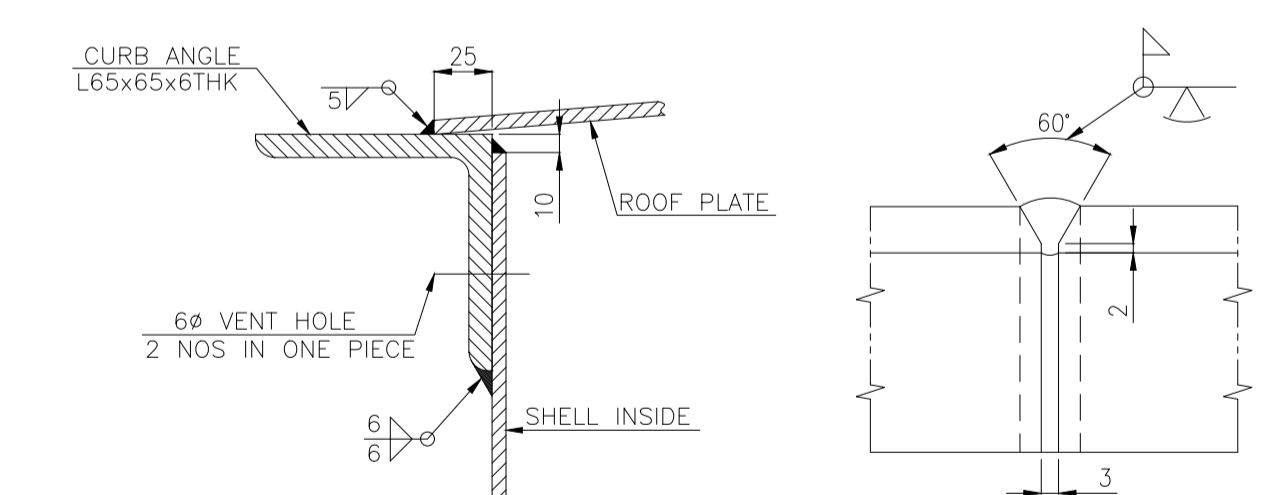

DETAIL 'D1' CURB ANGLE TO SHELL & ROOF JOINT DET.

TYP. WELD JOINT OF CURB ANGLE & WIND GIRDERS

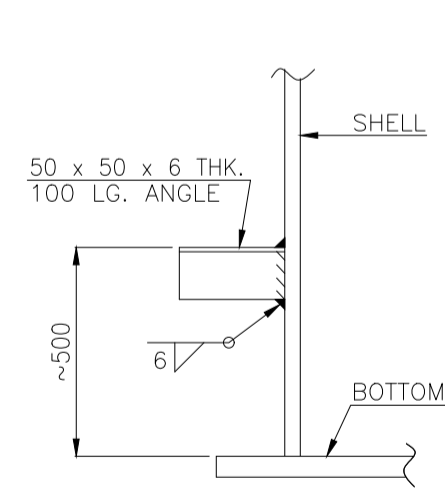

SETTLEMENT MARKER (QTY. 07 NOS)

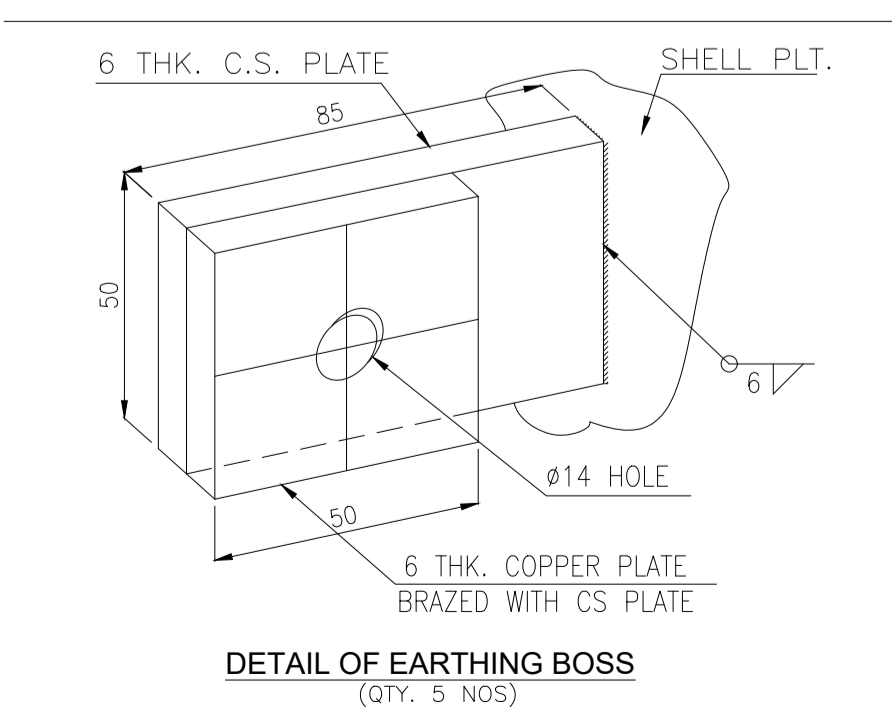

DETAIL OF EARTHING BOSS (QTY. 5 NOS)

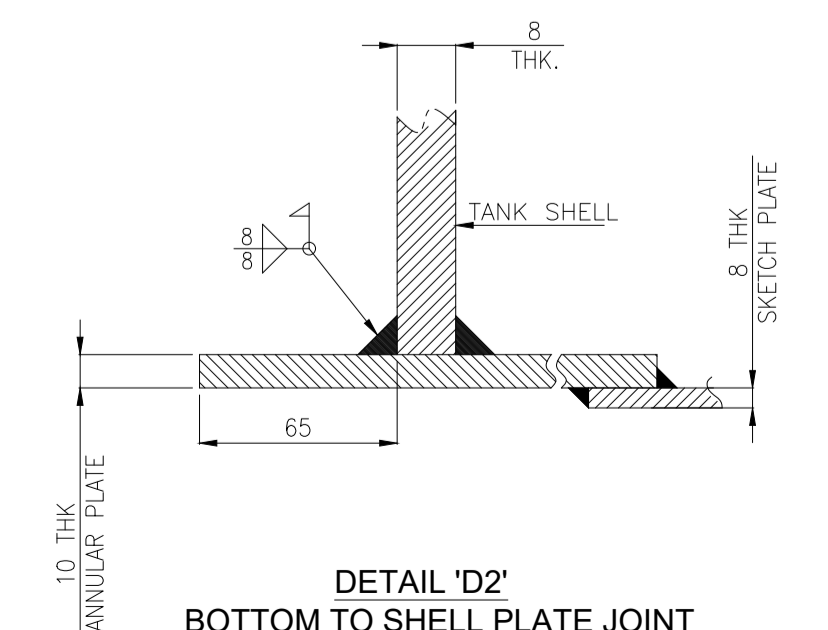

DETAIL 'D2' BOTTOM TO SHELL PLATE JOINT

REV.	DATE	DESCRIPTION	DRWN	CHKD	APPRD	MRPL
1	05-MAY-21	RE-ISSUE FOR BID		YG	KSH	ASN
0	08-FEB-21	ISSUE FOR BID		YG	KSH	ASN
C1	21-DEC-20	ISSUE FOR REVIEW/COMMENTS		BN	YG	KSH

CLIENT: **ONGC MANGALORE REFINERY AND PETROCHEMICALS LIMITED**  
(A subsidiary of Oil & Natural Gas Corpn. Ltd - ONGC)

PROJECT: **CONSTRUCTION OF MARKETING TERMINAL PROJECT AT DEVANGONTHI, BANGALORE.**

PROJECT MANAGEMENT CONSULTANT: **NAUVATA ENGINEERING PVT. LTD.**

DRAWING TITLE: **GENERAL ARRANGEMENT DRAWING FOR INTERPHASE TANK (FB-A-05A) 10,000 MTR DIA. x 15,000 MTR HT.**

CLIENT TENDER No:	DRAWING No:	SHT NO.	REV	SCALE:
320000428	20005-GEN-M-DW-4106	1 OF 1	1	1:1

ALL RIGHTS RESERVED. NO PART OF THIS DRAWING MAY BE REPRODUCED / STORED IN RETRIEVAL SYSTEM OR TRANSMITTED IN ANY FORM OR BY ANY MEANS ELECTRONIC, MECHANICAL, PHOTOCOPYING, XEROXING OR OTHERWISE WITHOUT PRIOR PERMISSION FROM NAUVATA ENGINEERING LTD./MRPL

DRAWING\_NO.: 20005-PR-0001

DESIGN CODE	API-650, LATEST EDITION	
STORED PRODUCT	WATER	
SIZE OF TANK	INSIDE DIAMETER-22.000 M & HEIGHT-14.000 M	
CAPACITY (PUMPABLE/LICENSE)	M <sup>3</sup>	4900/4900
NOS OF TANK	TWO	
TYPE OF ROOF	CONE ROOF	
CORROSION ALLOWANCE	3.0MM, OTHER-1ST SHELL COURSE & BOTTOM PLATE 1.5MM-OTHERS COURSES & ROOF PLATE	
LIQUID DENSITY	KG/M <sup>3</sup>	1000
MAX. DESIGN LIQUID LEVEL	M	14.0
DESIGN (POSITIVE) PRESSURE	MM WC	ATMOSPHERIC + FULL OF LIQUID
OPERATING PRESSURE	MM WC	ATMOSPHERIC
DESIGN TEMPERATURE (MAX/MIN)	°C	80
OPERATING TEMPERATURE	°C	45
MDMT TEMPERATURE	°C	0
TEST PRESSURE	Kg./cm <sup>2</sup> g	FULL OF WATER
JOINT EFFICIENCY	AS PER CODE	
RADIOGRAPHY	AS PER CODE	
FLASH POINT	°C	-
WIND SPEED	M/Sec	33(REFER SPEC OF TANKS-20005-GEN-M-SPE-4005
WIND PRESSURE	KG/M <sup>2</sup>	(REFER SPEC OF TANKS-20005-GEN-M-SPE-4005)
SEISMIC / ZONE	AS PER SPEC OF TANKS-20005-GEN-M-SPE-4005 (OUTSIDE SEISMIC ZONE)	
PAINTING	REFER PAINTING SPECIFICATION	
INSULATION / THK	NIL/-	
FLOW RATE (IN/OUT)	m <sup>3</sup> /hr.	100/2440
INSPECTION	CLIENT / TPI	
EMPTY WEIGHT	M.T.	~ 142.0
OPERATING WEIGHT	M.T.	~ 5319.16
HYDROTEST WT.	M.T.	~ 5319.16

**GENERAL NOTES (INDICATIVE ONLY, TO BE CONFIRMED BY CONTRACTOR DURING DETAIL ENGINEERING):-**

- ALL DIMENSIONS ARE IN MM UNLESS OTHERWISE SPECIFIED.
- ALL BUTT WELD SEAMS WITHOUT BACKING STRIP SHALL BE CHIPPED BACK TO SOUND METAL & REWELD.
- MANHOLE AND NOZZLE NECK 600NB AND ABOVE MAY BE FABRICATED FROM PLATE AND SHALL BE 100% RADIOGRAPHED.
- ALL NOZZLE 50NB AND BELOW SHALL BE STIFFENED BY 2 NOS, 50x6THK FLAT 90° APART.
- ALL NOZZLE AND MANHOLE BOLTS SHALL STRADDLE THE NEUTRAL AXIS OF EQUIPMENT.
- THE NOZZLE ABOVE 50NB SHALL BE PROVIDED WITH REINFORCEMENT PAD AS PER CODE.
- UNLESS OTHERWISE SPECIFIED, NOZZLE FLANGE SHALL CONFIRM TO ANSI/ASME B16, CLASS 150 FOR SIZES UP TO 600NB AND TO ASME B16.47 CLASS 150 FOR SIZES ABOVE 600NB.
- ALL COMPENSATION RINGS AND PADS SHALL BE PNEUMATICALLY TESTED WITH AIR AT 100 kPa(G) BY APPLYING SOAP SOLUTION ON OUTSIDE WELD. ALL REINFORCEMENT PADS SHOULD HAVE 6ø TELL-TALE ON HORIZONTAL CENTERLINE.
- PROJECTION OF SHELL NOZZLE ARE MENTIONED FROM OUTSIDE DIAMETER OF TANK /OUTER SURFACE OF ROOF OF TANK TO NOZZLE FLANGE FACE(i.e. GASKET SEATING FACE)
- DIMENSIONAL TOLERANCES SHALL BE IN ACCORDANCE WITH CLAUSE 7.5 OF API 650.
- VERTICAL JOINTS IN ADJACENT SHELL COURSES SHALL NOT BE IN ALIGNMENT BUT SHALL BE OFFSET FROM EACH OTHER BY 1/3RD OF THE PLATE LENGTH BUT IN NO CASE LESS THAN A DISTANCE OF 300 mm.
- GAUGE HATCH, TEMPERATURE ELEMENT & LEVEL TRANSMITTER SHOULD BE LOCATED AWAY FROM THE INLET AND OUTLET NOZZLE.
- ELECTRODES:- E-6013 : PLATES UP TO 12 THK.  
E-7018 : PLATES 12.5 THK AND ABOVE AND SHELL TO ANNULAR JOINT.
- THE TANKS SHALL BE MANUFACTURED, INSPECTED / TESTED, ERECTED & PAINTED AS PER LISTED SPECIFICATION
- EARTHING BOSS SHALL BE PROVIDED AS PER STD - RR/CR/236 & OISD 244.
- VENT SHALL BE CONSIDERED AS PER API 2000 APPLICABLE FOR API 650 OR TANK SHALL BE EQUIPPED WITH WEAK ROOF TO SHELL ATTACHMENT(FRAGILE JOINT) AS PER API 650 REQUIREMENTS.
- TANK ACCESSORIES ARE INDICATIVE, TO BE VERIFIED & UPDATED BY CONTRACTOR DURING DETAIL ENGINEERING.
- WEIGHT INDICATED TO BE INDICATIVE ONLY, TO BE CONFIRMED BY CONTRACTOR DURING DETAIL ENGINEERING.
- OPERATING CONDITIONS INDICATED ARE PRELIMINARY AND TO BE VERIFIED & UPDATED BY CONTRACTOR DURING DETAIL ENGINEERING.
- THIS DRAWING IS INDICATIVE ONLY, CONTRACTOR/VENDOR TO DEVELOP TANK GA FABRICATION DRAWING DURING DETAIL ENGINEERING & SUBMIT FOR PMC/COMPANY APPROVAL.
- MOC INDICATED TO BE VERIFIED AND CONFIRMED BY CONTRACTOR DURING DETAIL ENGINEERING
- DRAWING & DRAWING DETAILS ARE PRELIMINARY AND TO BE VERIFIED & UPDATED BY CONTRACTOR DURING DETAIL ENGINEERING.
- RING BEAM DESIGN SHALL BE CHECKED FOR SLENDERNESS BY LSTK CONTRACTOR.

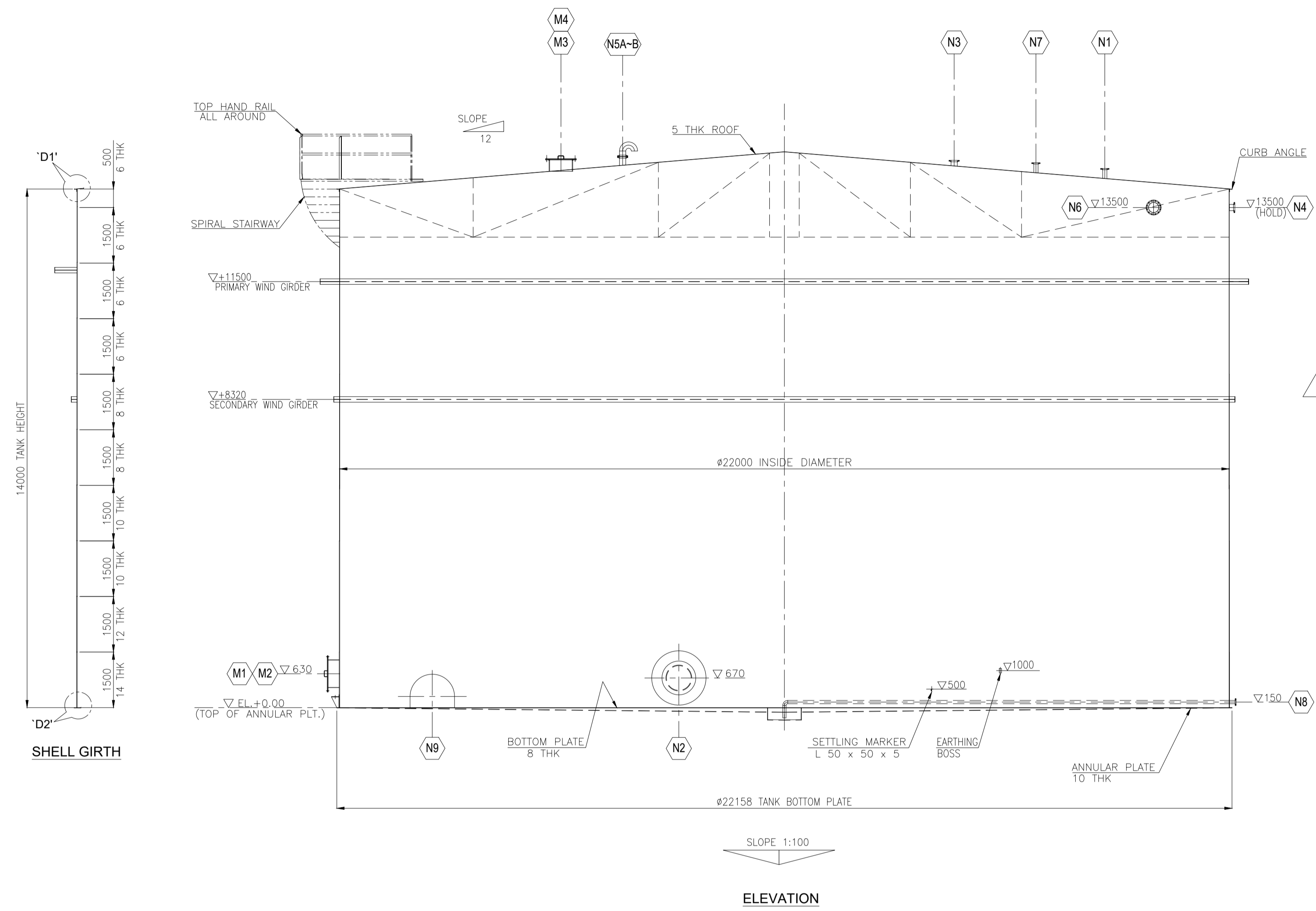

**MATERIAL SPECIFICATION (NOTE-21)**

BOTTOM, SHELL, ROOF & REINFORCEMENT PLATE	A36/IS 2062 Gr B
SHELL/ROOF NOZZLE NECK UP TO 250 NB.	SA 106 Gr.B
NOZZLE FLANGES	SA 105
MANHOLE NECK / FLANGE / COVER PLATE	A36/IS 2062 Gr B
SHELL NOZZLE NECK ABOVE 250 NB.	A36/IS 2062 Gr B
ROOF NOZZLE NECK ABOVE 250 NB.	A36/IS 2062 Gr B
BOLTING FOR NOZZLES	AS PER PMS
BOLTING FOR STRUCTURES	AS PER PMS
GASKETS	AS PER PMS
INTERNALS	A36/IS 2062 Gr B /A 106 Gr.B/SS304
STRUCTURES AND EXTERNALS (GUSSETS)	A36/IS 2062 Gr B
STAIRWAY PLATFORM AND STRUCTURAL	A36/A53/IS 2062 Gr A/B
HAND RAILING	A53/IS 2062 Gr A/B
GRATINGS	CS GALV.
GAUGE WELL/STILL WELL/SLEEVE	A 106 Gr.B
FITTINGS	SA 234 Gr.WPB
NAME PLATE / BRACKET	SS 304 / A36/IS 2062 Gr B
EARTHING CONN.	AS PER ELECTRICAL SPECIFICATION
LEG PIPE SUPT. / SLEEVE	A 106 Gr.B
ANCHOR BOLTS	A307 Gr.B/A563 Gr.A/IS 2062 Gr.B

**ACCESSORIES (NOTE-17)**

ACCESSORIES	SUPPLIED BY
ACCESS TO ROOF (SPIRAL STAIRWAY)	FABRICATOR
HANDRAIL AT TANK ROOF (ALL AROUND)	FABRICATOR
EARTHING BOSS WITH PIT	FABRICATOR
PLATFORM AT SHELL TOP AS PER STD	FABRICATOR
GASKETS FOR SHELL & FIXED ROOF NOZZLES	FABRICATOR
LEVEL TRANSMITTER	FABRICATOR

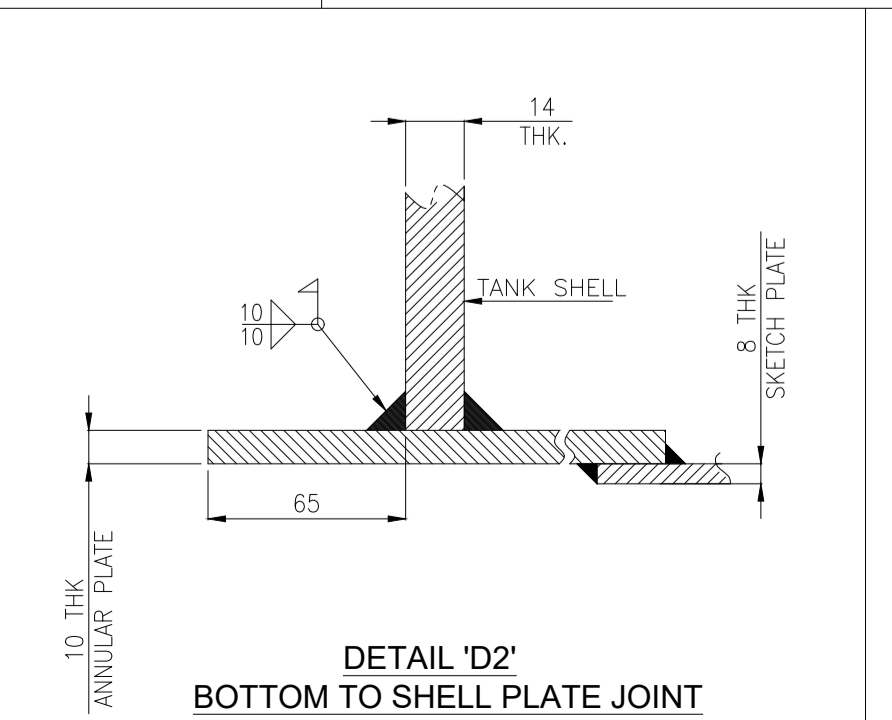
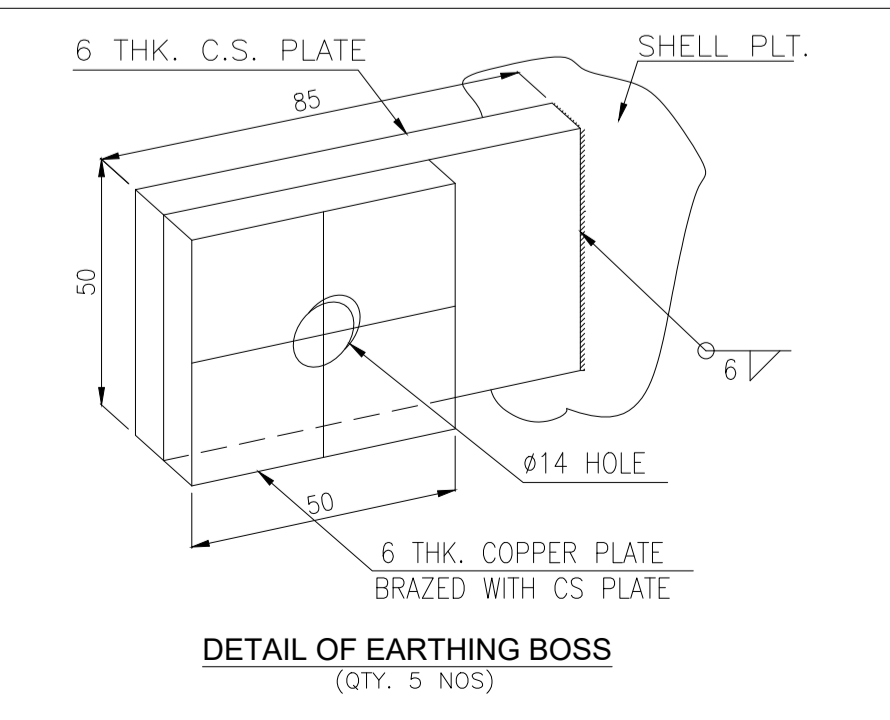
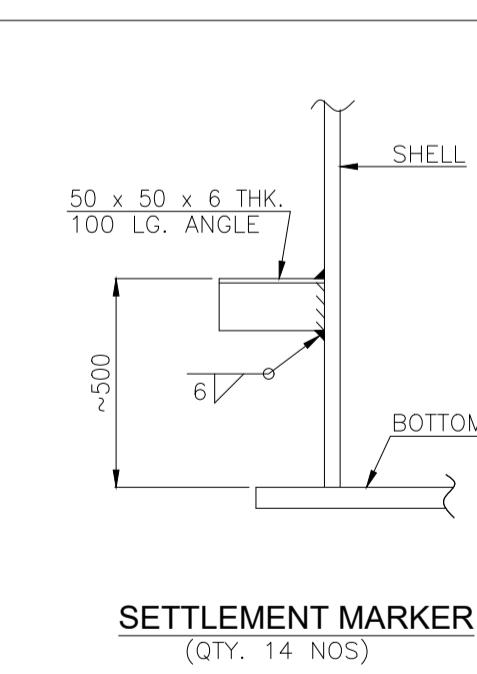
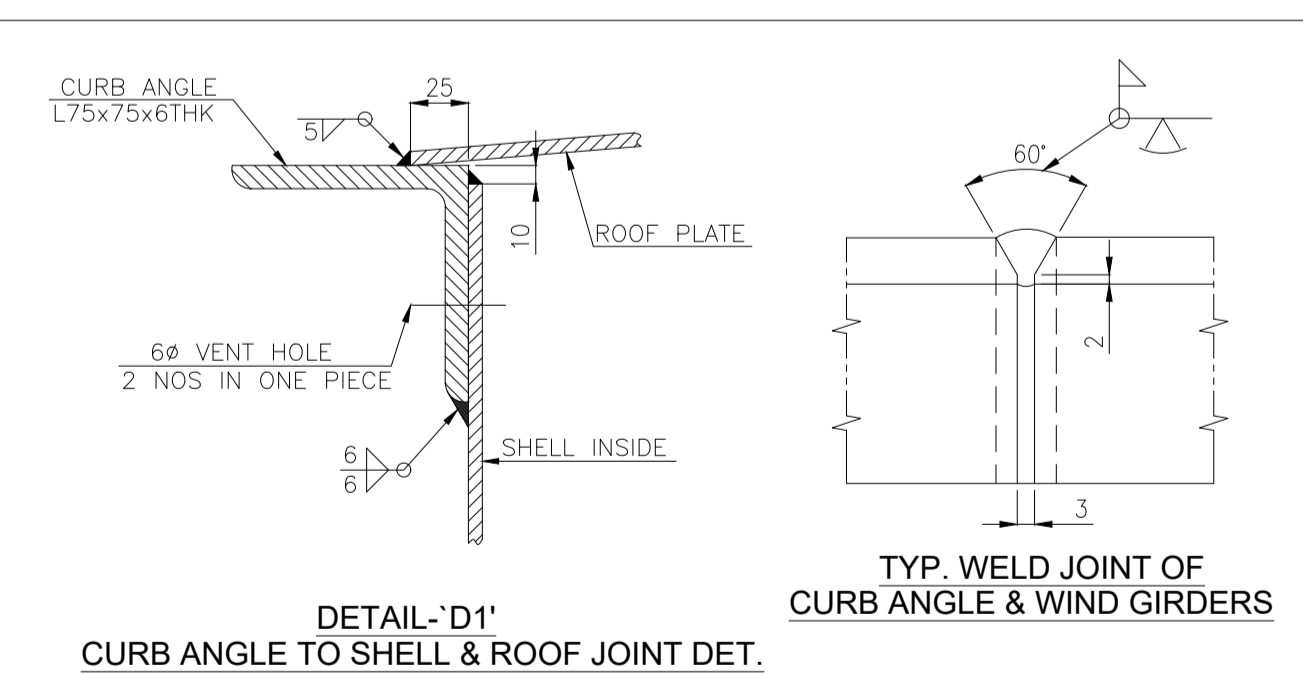
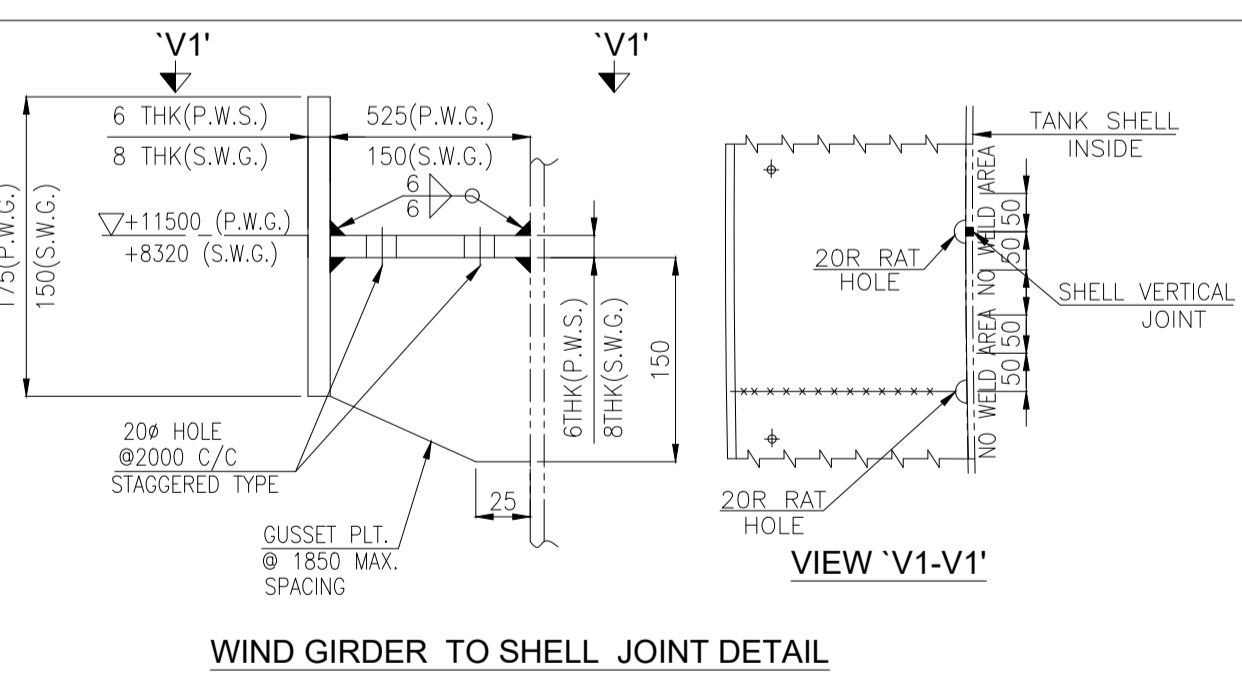

**NOZZLE SCHEDULE (INDICATIVE ONLY, TO BE CONFIRMED BY CONTRACTOR DURING DETAIL ENGINEERING):-**

MARK	NOZZLE SIZE	SCH/THK	QTY.	FLANGE		PROJ.	SERVICE
				RTG.	TYPE		
M1/2	600	8 THK	02	AS PER CODE		300	SHELL M/H WITH COVER
N2	600	80/12.7	01	300#	SO RF	300	OUTLET
N4	150	80/10.9	01	150#	SO RF	200	OVER FLOW
N6	300	80/17.4	01	150#	SO RF	225	RECIRCULATION LINE
N8	100	80/8.0	01	150#	SO RF	175	WATER DRAW OFF
N9	900x1200	14 THK	01	AS PER CODE		-	CLEAN OUT DOOR

MARK	NOZZLE SIZE	SCH/THK	QTY.	FLANGE		PROJ.	SERVICE
				RTG.	TYPE		
M3/4	600	5 THK	02	AS PER CODE		-	ROOF MANHOLE WITH COVER
N1	150	40/7.1	01	300#	SO RF	-	INLET
N3	200	40/8.1	01	300#	SO RF	-	LEVEL TRANSMITTER
N5A	300	40/7.1	01	150#	SO RF	-	ROOF VENT
N7	100	40/6.2	01	150#	SO RF	-	SPARE

REV.	DATE	DESCRIPTION	DRWN	CHKD	APPRD	MRPL
1	05-MAY-21	RE-ISSUE FOR BID		YG	KSH	ASN
0	08-FEB-21	ISSUE FOR BID		BN	YG	KSH
C1	21-DEC-20	ISSUE FOR REVIEW/COMMENTS		BN	YG	KSH

CLIENT: **ONGC MANGALORE REFINERY AND PETROCHEMICALS LIMITED**  
(A subsidiary of Oil & Natural Gas Corpn. Ltd - ONGC)



PROJECT: **CONSTRUCTION OF MARKETING TERMINAL PROJECT AT DEVANGONTHI, BANGALORE.**

PROJECT MANAGEMENT CONSULTANT: **NAUVATA ENGINEERING PVT. LTD.**

DRAWING TITLE: **GENERAL ARRANGEMENT DRAWING FOR FIREWATER TANK (FB-A-07A/B) 22.000 MTR DIA. x 14.000 MTR HT.**

ALL RIGHTS RESERVED. NO PART OF THIS DRAWING MAY BE REPRODUCED / STORED IN RETRIEVAL SYSTEM OR TRANSMITTED IN ANY FORM OR BY ANY MEANS ELECTRONIC, MECHANICAL, PHOTOCOPYING, XEROXING OR OTHERWISE WITHOUT PRIOR PERMISSION FROM NAUVATA ENGINEERING LTD./MRPL

DRAWING\_NO.: 20005-PR-0001

 <b>ONGC</b> ભજા અને પીટલ <b>MRPL</b>	<b>MRPL Marketing Terminal Project at Devangonhi, Bangalore</b> <b>Marketing Infrastructure Projects, MRPL</b>			 <b>nauvata</b> ENGINEERING & CONSULTING	
	Part – C	<b>SPECIFICATION</b>	Tender No. :		3200000495
	Section – C-3		Doc No.:		20005-GEN-M-SPE-4005
Subsection – C-3.10	<b>FOR TANKS</b>	Rev :	1		

<b>C-3</b>	<b>SPECIFICATIONS AND DATASHEETS</b>
<b>C-3.10</b>	<b>SPECIFICATION FOR TANKS</b>

## MRPL Marketing Terminal Project at Devangonhi, Bangalore



**PROJECT :** Marketing Infrastructure Projects, MRPL

**OWNER :** MANGALORE REFINERY AND PETROCHEMICALS LTD

**PMC :** Nauvata Engineering Pvt. Ltd.



**JOB NO. :** JBG20005

Rev. No	Date	Purpose	Prepared by	Checked by	Approved by
1	05-05-2021	RE-ISSUED FOR BID	YG	KSH	KSH
0	09-03-2021	ISSUED FOR BID	YG	KSH	KSH
C1	04-12-2020	ISSUED FOR REVIEW/COMMENTS	JSW	KSH	ASN

	<b>MRPL Marketing Terminal Project at Devangonhi, Bangalore</b> <b>Marketing Infrastructure Projects, MRPL</b>		Page 199 of 269		
	Part – C	<b>SPECIFICATION</b>  <b>FOR TANKS</b>	Tender No. :	3200000495	
	Section – C-3		Doc No.:	20005-GEN-M-SPE-4005	
Subsection – C-3.10		Rev :	1		



## TABLE OF CONTENTS

<b>1.</b>	<b>INTRODUCTION .....</b>	<b>5</b>
<b>2.</b>	<b>DEFINITIONS AND ABBREVIATIONS .....</b>	<b>5</b>
2.1.	Definitions.....	5
2.2.	Abbreviations.....	6
<b>3.</b>	<b>APPLICABLE CODES, STANDARDS, AND SPECIFICATIONS .....</b>	<b>6</b>
3.1.	Codes & Standards .....	6
3.2.	Project Reference Documents.....	8
<b>4.</b>	<b>UNITS OF MEASUREMENT.....</b>	<b>10</b>
<b>5.</b>	<b>ENVIRONMENTAL CONDITIONS.....</b>	<b>10</b>
5.1.	Site Data .....	10
5.2.	Design Life.....	10
5.3.	Noise Level.....	10
5.4.	Equipment Storage & Preservation.....	10
5.5.	Area Classification .....	10
5.6.	Available Utilities .....	11
<b>6.</b>	<b>HEALTH, SAFETY AND ENVIRONMENTAL REQUIREMENT .....</b>	<b>11</b>
<b>7.</b>	<b>SCOPE OF SUPPLY AND WORK .....</b>	<b>11</b>
7.1.	Spare Parts & Special Tools .....	12
<b>8.</b>	<b>MATERIALS .....</b>	<b>13</b>
8.1.	General .....	13



	<b>MRPL Marketing Terminal Project at Devangonhi, Bangalore</b> <b>Marketing Infrastructure Projects, MRPL</b>					
	Part – C	<b>SPECIFICATION</b>  <b>FOR TANKS</b>			Tender No. :	3200000495
	Section – C-3				Doc No.:	20005-GEN-M-SPE-4005
Subsection – C-3.10		Rev :	1			

<b>8.2.</b>	<b>Specifications for Carbon Steel Plates and Sections.....</b>	<b>13</b>
<b>8.3.</b>	<b>Bottom plates and roof plates .....</b>	<b>13</b>
<b>8.4.</b>	<b>Shell Plates and Bottom Annular Plates.....</b>	<b>13</b>
<b>8.5.</b>	<b>Bolting &amp; Gaskets.....</b>	<b>14</b>
<b>8.6.</b>	<b>Certification &amp; Marking.....</b>	<b>14</b>
<b>9.</b>	<b>DESIGN REQUIREMENT – VERTICAL TANKS .....</b>	<b>15</b>
<b>9.1.</b>	<b>General .....</b>	<b>15</b>
<b>9.2.</b>	<b>Design Life, Reliability and Maintenance .....</b>	<b>16</b>
<b>9.3.</b>	<b>Corrosion Allowance .....</b>	<b>16</b>
<b>9.4.</b>	<b>Design Loads .....</b>	<b>16</b>
<b>9.5.</b>	<b>Bottom Plates &amp; Annular Plates .....</b>	<b>17</b>
<b>9.6.</b>	<b>Shell Design .....</b>	<b>18</b>
<b>9.7.</b>	<b>Shell Openings .....</b>	<b>18</b>
<b>9.8.</b>	<b>Stiffening Ring, Curb Angles and Compression Rings .....</b>	<b>19</b>
<b>9.9.</b>	<b>Roof Design.....</b>	<b>20</b>
9.9.1.	Fixed roof.....	20
9.9.2.	Internal Floating Roof .....	21
9.9.3.	Floating Roof Accessories .....	23
9.9.3.1.	Roof seals .....	23
9.9.3.2.	Roof penetrations & nozzles .....	23
9.9.3.3.	Floating suction .....	24
9.9.3.4.	Floating roof support legs .....	25
9.9.3.5.	Earthing (grounding).....	26
9.9.3.6.	Anti-rotation and Centering Devices .....	26
9.9.3.7.	Foam Dams and Foam Chambers.....	27
<b>9.10.</b>	<b>Wind Girders .....</b>	<b>27</b>
<b>9.11.</b>	<b>Internal Attachments.....</b>	<b>27</b>
<b>9.12.</b>	<b>External Attachments .....</b>	<b>28</b>
9.12.1.	Platforms, walkways and stairs .....	28
9.12.2.	Tank Earthing.....	29
9.12.3.	Miscellaneous .....	29



 <b>ONGC</b> ॐ नमो भगवते वासुदेवाय <b>MRPL</b>	<b>MRPL Marketing Terminal Project at Devangonhi, Bangalore</b> <b>Marketing Infrastructure Projects, MRPL</b>		Page 201 of 269		 <b>nauvata</b> ENGINEERING & CONSULTING
	Part – C	<b>SPECIFICATION</b>	Tender No. :	3200000495	
	Section – C-3		Doc No.:	20005-GEN-M-SPE-4005	
Subsection – C-3.10	<b>FOR TANKS</b>	Rev :	1		

9.12.4.	Foam Tanks .....	29
<b>10.</b>	<b>DESIGN REQUIREMENTS – HORIZONTAL TANKS .....</b>	<b>30</b>
10.1.	General .....	30
10.2.	Shell & End Plate Joints.....	30
10.3.	Fittings.....	31
10.4.	Nozzles and Reinforcing Pads / Pad Flanges.....	31
10.5.	Special Requirements - Corrosion Protection .....	31
<b>11.</b>	<b>FABRICATION &amp; WELDING REQUIREMENTS .....</b>	<b>31</b>
11.1.	Fabrication.....	31
11.2.	Erection .....	33
11.3.	Welding.....	34
<b>12.</b>	<b>INSPECTION &amp; TESTING .....</b>	<b>36</b>
12.1.	General .....	36
12.2.	Non-Destructive Examination.....	37
12.3.	Hydro Test .....	38
12.4.	Tank Settlement Measurements.....	40
12.5.	Underground (Horizontal) tank pneumatic / Hydro tests .....	40
<b>13.</b>	<b>SURFACE PREPARATION &amp; PAINTING REQUIREMENTS .....</b>	<b>41</b>
<b>14.</b>	<b>PREPARATION FOR SHIPMENT.....</b>	<b>42</b>
<b>15.</b>	<b>DOCUMENTATION .....</b>	<b>42</b>
<b>16.</b>	<b>WARRANTY.....</b>	<b>44</b>
<b>17.</b>	<b>QUALITY ASSURANCE .....</b>	<b>44</b>

	<b>MRPL Marketing Terminal Project at Devangonhi, Bangalore</b>			Page 202 of 269
	<b>Marketing Infrastructure Projects, MRPL</b>			
	Part – C	<b>SPECIFICATION  FOR TANKS</b>	Tender No. :	
Section – C-3	Doc No.:		20005-GEN-M-SPE-4005	
Subsection – C-3.10	Rev :		1	

## 1. INTRODUCTION

This specification provides the purchaser's minimum requirements for design, selection of materials, fabrication, erection, inspection and testing of vertical cylindrical above ground welded storage tanks as well as Horizontal tanks for bulk storage of petroleum products, hydrocarbons and other utility storage to be installed at Mangalore Refinery & Petrochemicals Limited (MRPL) Devangonhi Terminal.

This Specification together with the referenced documents covers the minimum requirements for design, fabrication, construction, inspection, testing & supply of various Vertical Storage Tanks of Fixed Roof and Floating Roof Type as per API Std 650: 2020, Horizontal Underground Tanks as per IS 10987:1992 and Stainless Steel Vertical tanks.

## 2. DEFINITIONS AND ABBREVIATIONS

### 2.1. Definitions



The CLIENT / COMPANY / OWNER where used in this specification shall mean the ultimate user / owner of the plant and facilities.

The CONTRACTOR / PURCHASER where used in this specification shall mean the party, who undertake LSTK / EPC contract for the above project.

The VENDOR / SUPPLIER where used in this specification shall mean the party, who manufactures or supplies the equipment and services specified.

The INSPECTOR / TPIA / TPI where used in this specification shall mean the PURCHASER / COMPANY or their authorized Third Party Agency for carrying out the inspection.

The PMC where used in this specification shall mean the party, who perform Project Management for COMPANY.

	<b>MRPL Marketing Terminal Project at Devangonhi, Bangalore</b>		Page 203 of 269		
	<b>Marketing Infrastructure Projects, MRPL</b>		Tender No. :	3200000495	
	Part – C	<b>SPECIFICATION</b>  <b>FOR TANKS</b>	Doc No.:	20005-GEN-M-SPE-4005	
Section – C-3	Rev :		1		
Subsection – C-3.10					

## 2.2. Abbreviations

API	American Petroleum Institute
ASME	American Society of Mechanical Engineers
ASTM	American Society for Testing and Materials
ASCE	American Society of Civil Engineers
ATF	Aviation Turbine Fuel
AWS	American Welding Society
CI	Cast Iron
CRVT	Cone roof Vertical tanks
FR	Floating Roof
GA	General Arrangement
IFRVT	Internal Floating Roof Vertical tank
IS	Indian Standards
NB	Nominal Bore
OISD	Oil Industry Safety Directorate
SS	Stainless Steel



## 3. APPLICABLE CODES, STANDARDS, AND SPECIFICATIONS

Contractor / Vendor shall follow the latest revision of all Documents and Specifications indicated in the Material Requisition or any later revisions as mutually agreed. Codes and standards shall be the latest edition including latest addenda unless otherwise specified in the Requisition documents.



In cases where no specific requirements are given or referenced in this specification for a specific component, Contractor / Vendor shall adhere to internationally accepted design and engineering practices.

### 3.1. Codes & Standards

Sl. No.	Document No.	Title
1.	API Std 650	Welded Tanks for Oil Storage.
2.	IS 10987	Code of practice for Design, Fabrication, Testing and Installation of under-ground/above-ground horizontal cylindrical steel storage tanks for petroleum products.
3.	IS 875 (Part 3)	Code of Practice - Design loads Wind Loads (other than earthquake) for building and structures Part 3 Wind Loads.

	<b>MRPL Marketing Terminal Project at Devangonhi, Bangalore</b>			Page 204 of 269
	<b>Marketing Infrastructure Projects, MRPL</b>			
	Part – C	<b>SPECIFICATION</b>  <b>FOR TANKS</b>	Tender No. :	
	Section – C-3		Doc No.:	20005-GEN-M-SPE-4005
Subsection – C-3.10	Rev :		1	



4.	IS 1893 (Part 1)	Criteria for Earthquake resistant design of structures – General Provisions.
5.	IS 1893 (Part 4)	Criteria for Earthquake resistant design of structures – Industrial Structures.
6.	IS 2007	Method for Calibration of Vertical Oil Storage tanks
7.	IS 2062	Hot Rolled Medium and High Tensile Structural Steel - Specification
8.	API RP 652	Linings of Aboveground Petroleum Storage Tank Bottoms, 5th Ed
9.	API Std 2000	Venting Atmospheric and Low-Pressure Storage Tanks
10.	API-RP 2003	Protection Against Ignition Arising Out of Static, Lightning and Stray Currents
11.	API RP 2350	Overfill Protection for Storage Tanks in Petroleum Facilities
12.	ISO 1461	Hot dip galvanized coatings on fabricated iron and steel articles - Specifications and test methods
13.	NFPA 11	Standard for Low-, Medium-, and High-Expansion Foam
14.	NFPA 13	Standard for the Installation of Sprinkler Systems
15.	NFPA (fire) 329	Recommended Practice for Handling Releases of Flammable and Combustible Liquids and Gases
16.	NFPA 15	Standard for Water Spray Fixed Systems for Fire Protection
17.		Aluminium Design Manual
18.		Uniform Building code
19.	EN 10204	Metallic Products – Type of Inspection Document
20.	ISO 10474	Steel and Steel Products – Inspection Documents
21.	OISD-RP-108	Recommended Practices on Oil Storage and Handling
22.	OISD-STD-117	Fire Protection Facilities for petroleum depots, terminals and pipeline/lube oil installations
23.	OISD-STD-244	Storage and handling of Petroleum products at depots and terminals including Standalone Crude Oil Storage facilities

	<b>MRPL Marketing Terminal Project at Devangonhi, Bangalore</b>		Page 205 of 269	
	<b>Marketing Infrastructure Projects, MRPL</b>			
	Part – C	<b>SPECIFICATION</b>  <b>FOR TANKS</b>	Tender No. :	
Section – C-3	Doc No.:		20005-GEN-M-SPE-4005	
Subsection – C-3.10	Rev :		1	



24.	OISD-GDN-180	Lightning Protection
25.	M B Lal committee recommendations	
<b>Statutory Approvals</b>		
	<b>Relevant Approval &amp; Clearance</b>	<b>Responsible Government Entity</b>
1.	Clearance for handling & storage of Petroleum Products	Chief Controller of Explosives (CCOE) / Petroleum And Explosives Safety Organization (PESO)
2.	Clearance from Environment / Pollution board	State Pollution Control Board & CPCB
3.	Clearance of the Ministry of Environment and Forests following consideration of the Environment Impact Assessment & Environment Management Plan pursuant to Sections 3(1) & 3(2) (v) of the Environment (Protection) Act, 1985 and Rules 5(3)(a) of the Environment (Protection) Rules, 1986	Ministry of Environment and Forests
4.	Approval of the Chief Engineer Inspector	Commissioner of Electricity, Government of Karnataka
5.	Consent under the Factories Act 1948 relating to firefighting capability	Government of Karnataka
6.	Consent of the Controller of Explosives to the possession and use of explosives for the purpose of blasting	Controller of Explosives
7.	Fire Service	Government of Karnataka
8.	CPWD / PWD	Government of Karnataka
9.	OISD Audit	Oil Industry Safety Directorate

### 3.2. Project Reference Documents

Sl. No.	Document No.	Title
1.	20005-GEN-G-DOC-9125	Marketing Terminal Design Basis
2.	20005-GEN-M-EDB-4001	Engineering Design Basis for Rotating equipment
3.	20005-GEN-M-EDB-4002	Engineering Design Basis for Static Equipment
4.	20005-GEN-L-EDB-3104	Engineering Design Basis for Piping
5.	20005-GEN-I-EDB-6009	Engineering Design Basis for Instrumentation

	<b>MRPL Marketing Terminal Project at Devangonhi, Bangalore</b>			Page 206 of 269
	<b>Marketing Infrastructure Projects, MRPL</b>			
	Part – C	<b>SPECIFICATION</b>  <b>FOR TANKS</b>	Tender No. :	
	Section – C-3		Doc No.:	20005-GEN-M-SPE-4005
Subsection – C-3.10	Rev :		1	

Sl. No.	Document No.	Title
6.	20005-GEN-E-EDB-5006	Engineering Design Basis for Electrical
7.	20005-GEN-S-EDB-2011	Engineering Design Basis for General Civil
8.	20005-GEN-S-EDB-2015	Engineering Design Basis Structural and Architectural
9.	20005-GEN-L-SPE-3101	Piping Material Specification
10.	20005-GEN-L-SPE-3102	Valve Material Specification
11.	20005-GEN-L-DW-3001	Overall Plot Plan
12.	20005-GEN-G-EDB-9120	Engineering Design Basis Safety Requirements for Contractor
13.	20005-GEN-G-DOC-9123	Mandatory Spare Parts
14.	20005-GEN-G-DOC-9137	Spare Parts Philosophy
15.	20005-GEN-G-EDB-9122	Engineering Design Basis Surface Preparation And Protective Coating
16.	20005-GEN-M-DS-4025	Data Sheet for MS Tank
17.	20005-GEN-M-DS-4026	Data Sheet for HSD Tank
18.	20005-GEN-M-DS-4027	Data Sheet for ATF Tank
19.	20005-GEN-M-DS-4028	Data Sheet for Bio-Diesel Tank
20.	20005-GEN-M-DS-4029	Data Sheet for Interphase Tank
21.	20005-GEN-M-DS-4030	Data Sheet for Ethanol Tank
22.	20005-GEN-M-DS-4031	Data Sheet for HSD Underground Tank
23.	20005-GEN-M-DS-4032	Data Sheet for Slop Underground Tank
24.	20005-GEN-M-DS-4033	Data Sheet for MS Underground Tank
25.	20005-GEN-M-DS-4034	Data Sheet for Fire Water Tank
26.	20005-GEN-M-DS-4035	Data Sheet for Foam Tank
27.	20005-GEN-M-DW-4100	GAD for Foam Tank
28.	20005-GEN-M-DW-4101	GAD for MS Above Ground Tank
29.	20005-GEN-M-DW-4102	GAD for HSD Above Ground Tank
30.	20005-GEN-M-DW-4103	GAD for ATF Above Ground Tank
31.	20005-GEN-M-DW-4104	GAD for Ethanol Tank
32.	20005-GEN-M-DW-4105	GAD for Bio-Diesel Tank
33.	20005-GEN-M-DW-4106	GAD for Interface Tank
34.	20005-GEN-M-DW-4107	GAD for Fire Water Tank

	<b>MRPL Marketing Terminal Project at Devangonhi, Bangalore</b>			Page 207 of 269	
	<b>Marketing Infrastructure Projects, MRPL</b>				
	Part – C	<b>SPECIFICATION</b>  <b>FOR TANKS</b>	Tender No. :	3200000495	
Section – C-3	Doc No.:		20005-GEN-M-SPE-4005		
Subsection – C-3.10	Rev :		1		

Sl. No.	Document No.	Title
35.	20005-GEN-M-DW-4108	GAD for MS Under Ground Tank
36.	20005-GEN-M-DW-4109	GAD for HSD Under Ground Tank
37.	20005-GEN-M-DW-4110	GAD for Slop Under Ground Tank

#### 4. UNITS OF MEASUREMENT

Unless otherwise specified, all units of measurement shall be in accordance with SI units.

#### 5. ENVIRONMENTAL CONDITIONS

##### 5.1. Site Data

Maximum ambient temperature (Monthly Average) 34 °C

Average Temperature 23 °C

Minimum ambient temperature (Monthly Average) 16 °C

Relative humidity 25 % - 85 %

##### Meteorological Data

Seismic Zone as per IS 1893 (Part I) 2016: II, Zone factor 0.1

Average wind speed 5 km/h (Design wind speed as per IS 875 is 33 m/sec)

Wind Direction North-West

Rainfall Data: Maximum rainfall (in mm) per hour 18.5 mm

##### 5.2. Design Life

The equipment/packages and their components shall be designed and constructed for a design life of 25 years.

##### 5.3. Noise Level



Refer COMPANY document –Engineering Design Basis for Rotating Equipment for allowable noise levels.

##### 5.4. Equipment Storage & Preservation

Export packing & preservation for all items in SUPPLIER's scope shall be suitable for seaworthy, road transport & site storage for a minimum initial period of 18 months. Packaging shall be done with suitable vapour corrosion inhibitors (VCI).

##### 5.5. Area Classification

Electrical and Instrumentation equipment supplied part of mechanical equipment and packages shall be suitable for the applicable Hazardous Area Classification as specified in equipment datasheet / specification.

 <b>ONGC</b> ॐ नमो भगवते वासुदेवाय <b>MRPL</b>	<b>MRPL Marketing Terminal Project at Devangonhi, Bangalore</b>			Page 208 of 269	 <b>nauvata</b> ENGINEERING & PROJECT MANAGEMENT
	<b>Marketing Infrastructure Projects, MRPL</b>		Tender No. :	3200000495	
	Part – C	<b>SPECIFICATION</b>  <b>FOR TANKS</b>	Doc No.:	20005-GEN-M-SPE-4005	
Section – C-3	Rev :		1		
Subsection – C-3.10					

#### 5.6. Available Utilities

Electrical Power	415V, 3ph, 3/4W, 50 Hz 230V AC, 1Ph+N, 50 Hz
Instrument Air	Yes
Cooling water	Not Available

#### 6. HEALTH, SAFETY AND ENVIRONMENTAL REQUIREMENT

Health, Safety and Environmental (HSE) consideration is of foremost importance. Hence, in case of a local regulation whose specification and requirements are more stringent than the listed specifications, the more stringent will apply.

The Vendor shall be responsible for ensuring that the equipment/system supplied meets all applicable regulations on health, safety and environment. It shall be designed to operate safely and satisfactorily at all expected combinations of process, utilities and site conditions which include those at start-up, operation, shutdown and emergency cases while retaining the overall system security, reliability and availability.

The Owner / EPC Contractor reserves the right to audit the Vendor at any time to ensure the Vendor's HSE Management System promotes the safety, environmental protection and integrity of the equipment.

#### 7. SCOPE OF SUPPLY AND WORK



Vendor's scope of work, supply and services shall be as per the requisition and Mechanical datasheets. The tanks list is as below:

Sl. No.	Product	No. of Tanks	Tank Size DIA x H / L m X m	Total Volume KL	Tank Type
1.	MS	3	24 X 20	9000	A/G IFR
2.	HSD	3	24 X 20	9000	A/G CR
3.	ATF	3	24 X 20	9000	A/G CR
4.	Bio Diesel	2	9 X 9	575	A/G CR
5.	Interface	1	10 X 15	1150	A/G CR
6.	ETHANOL	2	9 X 9	575	A/G CR
7.	HSD	1	2.75 x 13	77	U/G
8.	SLOP	1	2.75 X 13	77	U/G
9.	ATF	1	2.75 X 13	77	U/G
10	Fire Water	2	22 X 14	5300	A/G CRVT
11	Foam Tank	2	1.8 X 3.5	7	Vertical, SS

Four (4) tanks are considered in HSD service. One (01) of the four tanks is identified for future installation.

Following shall be included in Contractor / Vendor, scope unless otherwise specified otherwise.



	<b>MRPL Marketing Terminal Project at Devangonhi, Bangalore</b> <b>Marketing Infrastructure Projects, MRPL</b>		Page 209 of 269		
	Part – C	<b>SPECIFICATION</b>  <b>FOR TANKS</b>	Tender No. :	3200000495	
	Section – C-3		Doc No.:	20005-GEN-M-SPE-4005	
Subsection – C-3.10	Rev :		1		

- Mechanical & structural Design and Engineering of the Tanks
- Preparation of design calculations, datasheets and detailed shop/ site fabrication and erection drawings
- Supply of all materials as steel plates, structural, pipes & fitting, flanges and fasteners
- Fabrication of tank shell, bottom and roof along with all nozzles, Man ways, roof structure, Bottom sump, Cleanout door etc. as specified in data sheets.
- Internal floating roof, as applicable or as specified in datasheets.
- External accessories such as Vent with goose neck & bird screen, emergency vents, Gauge /Sample hatches with slot dipping device, pressure vacuum safety valves (PVSV)/ Breather Valve (If required) etc.
- Internal accessories such as Tank mixers, floating suction, floating roof supports, still wells etc. as applicable.
- Earthing connections, nameplates, Pipe support cleats, internal / external supports and still well for the instrumentation as required.
- Spiral stairways / caged ladders, Top railing and access platforms / intermediate landing as required.
- Supply & Installation of Cathodic protection clips and supports, if specified.
- Supply Anchor chairs and anchor bolts, if required, as per wind, seismic, other loading design
- All spare nozzles shall be provided with blind flanges, gaskets and bolting as required.
- All NDT as required as per specifications and applicable codes
- PWHT as per code /specifications
- Inspection and testing including hydrostatic testing, draining and drying afterwards.
- Surface preparation and primer application (at shop for prefabricated material) as well as internal and external painting as specified in datasheets/specifications
- All necessary special tools for installation and maintenance.
- Name Plates, supply engraving and attachment
- Supply Spare parts as specified below
- Any other material required to complete the tanks fabrication and installation.



#### 7.1. Spare Parts & Special Tools

Two years operational spare parts will be recommended by the Vendor along with a price list.

Contractor shall supply mandatory spares.

Pre commissioning, Commissioning & initial start-up spares: Spare parts needed to adequately cover the requirements of day-to-day maintenance and any premature failures during the period of start-up and trial run operations shall be included in scope.

As a minimum Commissioning & Start-up spares shall be provided as, 200 % spare gaskets (plus 1 installed) and 10% spare bolting (minimum 2 nos. each size) for all blanked nozzles & manways.

	<b>MRPL Marketing Terminal Project at Devangonhi, Bangalore</b>		Page 210 of 269		
	<b>Marketing Infrastructure Projects, MRPL</b>		Tender No. :	3200000495	
	Part – C	<b>SPECIFICATION</b>	Doc No.:	20005-GEN-M-SPE-4005	
Section – C-3	Rev :		1		
Subsection – C-3.10	<b>FOR TANKS</b>				

Special Tools: Any specific/custom tools, items, jigs, etc required for installation, commissioning, repair, or maintenance of the equipment that are unique or unusual. These are to be recommended by the Vendor and supplied along with the equipment.

## 8. MATERIALS

### 8.1. General

Material used for construction of tanks shall be as specified on the equipment data sheets. Material of construction of all tanks shall be carbon steel and shall be selected from one of the many grades provided in Table 4-4a of API Std 650. Carbon steel material other than those listed in API Std 650 may not be used, without prior PMC approval.

For services requiring austenitic steel tanks, the type of steel shall be specified on tank data sheet.

All materials shall be suitable for the minimum design metal temperature (MDMT) specified on storage tank datasheet.

All materials used for tank fabrication shall be new and free from pits, scale, laminations and other defects and shall satisfy the requirements of codes and standards specified in tank data sheet.

For all Material of Construction, requirement of Impact Testing shall be complied with as per API 650.

### 8.2. Specifications for Carbon Steel Plates and Sections

All steel shall be made by the basic oxygen or electric furnace process. Bessemer or rimming steels shall not be used.

For thickness greater than 12.5 mm, ASTM A 283 Gr. C plates shall not be used for shell, shell reinforcement or tank bottom annular plates.

Shell plates, annular plates, bottom plates attached to shell plates by welding, shell reinforcing and insert plates, plates used for manhole and nozzle necks and manhole cover plates shall meet the impact testing requirements of clause 4.2 of API Std 650.

### 8.3. Bottom plates and roof plates



A certificate from steel mill is required only to confirm that the steel is made according to one of above-mentioned processes.

### 8.4. Shell Plates and Bottom Annular Plates

The steel shall not contain more than 0.23% carbon, 0.05% sulphur and 0.05% phosphorus, as determined by ladle analysis.

The steel shall have a guaranteed minimum ultimate tensile strength of at least 363 MPa and maximum ultimate tensile strength of not more than 510 MPa. The steel shall have guaranteed yield strength of at least 206 MPa. The steel shall have an elongation not less than 22%.

Mill certificates shall be supplied shall indicate the steel making process as well as the parameters stated in material specification and this guide.

	<b>MRPL Marketing Terminal Project at Devangonhi, Bangalore</b> <b>Marketing Infrastructure Projects, MRPL</b>		Page 211 of 269		
	Part – C	<b>SPECIFICATION</b>  <b>FOR TANKS</b>	Tender No. :	3200000495	
	Section – C-3		Doc No.:	20005-GEN-M-SPE-4005	
Subsection – C-3.10	Rev :		1		

To promote weldability, the carbon content and carbon equivalent (Ceq) of carbon and carbon manganese steels to be used for storage tanks shall comply with the following:

- Carbon content shall not exceed 0.23%, except for forgings and castings, where this may be relaxed to 0.25%.
- In addition, one of the following carbon equivalent requirements, based on ladle analysis shall be satisfied:
  - $Ceq = C + Mn/6 \leq 0.42\%$  (1)
  - $Ceq = C + Mn/6 + (Cr+Mo+V)/5 + (Ni+Cu)/15 \leq 0.43\%$  (2)

Formula (1) may be used if the material standard specifies C and Mn only. Otherwise formula (2) shall be used in which case all the elements specified shall be determined per heat.

Floating roof pipe supports and pipe sleeves shall be of carbon steel conforming to seamless ASTM A-106, A-53, API.5L, IS:1978 or equivalent.

#### 8.5. Bolting & Gaskets

Bolt material shall be specified in Mechanical data sheet. Unless otherwise specified all Flange, bolting material shall conform to SA193 Grade B7 bolts with SA194 Grade 2H nuts. All bolts heads and nuts shall be heavy head pattern. For corrosion protection all carbon steel bolting of tanks shall be hot dip galvanized in accordance with ISO 1461. Bolts and nuts for all structural shall conform to IS 1363. Bolt and nuts for Manholes shall conform to ASTM A 307 Gr.B or IS 1367 Cl. 4.6/ C1.4.0

Gaskets shall be furnished by the Vendor for all bolted attachments i.e. cover plates, man ways and blind flanges supplied with tanks. Gasket material shall be as specified in the individual tank Mechanical Data Sheet. Non-Asbestos type gaskets shall be used for all tanks. Gaskets used for hydrostatic testing shall be of the same grade as the service gaskets. Following hydrostatic test all gaskets shall be replaced.



#### 8.6. Certification & Marking

The Vendor shall supply mill test certificates on all plates, pipes, nozzles and appurtenances to be used for tank construction. Material without appropriate mill test certificates will be not accepted.

The certificates shall record yield and tensile strengths, impact strength and chemical properties and values. Materials shall conform to designated ASTM standards or other recognized international standards.

As a minimum material certification for all materials used in the tank construction shall be in accordance with EN 10204. All Pressure parts or parts in contact with fluid shall have EN 10204 Type 3.1 certification or 3.2 if third party inspection is specified in the contract. All other materials shall have Type 2.2 certification. Materials without traceability shall not be used.

All material shall be identifiable against its material certificate. Identification marks shall be transferred prior to cutting. Materials shall not be hard stamped or pop marked. All markings shall be carried out using low stress stamps or etching.

	<b>MRPL Marketing Terminal Project at Devangonhi, Bangalore</b>			Page 212 of 269	
	<b>Marketing Infrastructure Projects, MRPL</b>			Tender No. : 3200000495	
	Part – C Section – C-3	<b>SPECIFICATION</b>  <b>FOR TANKS</b>	Doc No.: 20005-GEN-M-SPE-4005	Rev : 1	
Subsection – C-3.10					

The country of origin and production mill for materials shall be specified by the Vendor in their Tender. Vendor shall submit sufficient documents of the proposed mill/s with their Tender for Purchaser's review to conform that the mill/s manufacture/s steel as per relevant ASME standards (or equivalent standards if the materials other than that listed in Table 4.4 of API 650 are proposed by Vendor with Purchaser's prior approval) and the process conforms to EN 10204 type.3.2 for certification.

All plates provided and used in the construction of the tank shall be of fresh manufacture and in its first use. No repair on the plates is allowed on the plates for any reason whatsoever except for repair of tack welds used in normal erection practice.

The specified plate thickness arrived by code calculation for design and hydro test shall be the minimum thickness of the plate at any point whatsoever.

IS 2062 Grade E250 BR/B0 may be considered equivalent to A36 materials and may be used for tanks, subject to PMC / MRPL approval.

Supply of steel plates for A/G and U/G tanks conforming to IS 2062, Gr.-B (Fe 410, E-250) of tested quality. Thickness of plate should be as per drawing. The steel plates are to be procured in general from manufactures such as viz. SAIL / TISCO / ESSAR / LLOYDS/ISPAT/ JINDAL SALEM STEEL or from any authorized stockists /dealers of above manufacturing companies. The vendor will be asked to furnish the invoices & test certificates from the manufacturer/stockists/dealer for each lot of steel plates procured.

- Minimum 10% of steel plates procured are to be tested for Ultrasonic tests.
- Sample pieces from each lot are to be tested in local government approved metallurgical labs for both physical and chemical properties and confirming equivalent to or more than IS 2062 Gr B requirements.



## 9. DESIGN REQUIREMENT – VERTICAL TANKS

### 9.1. General

Design requirements for the Tanks are defined in the Material Requisition, referred data sheets, this specification, other referenced specifications, codes and standards. Vendor is responsible for ensuring that storage tanks and components provided are suitable for the design and operating conditions stated in the equipment datasheets.

Tanks shall be designed & constructed in accordance with Latest edition of API Std 650. Tank venting calculation shall be carried out as per latest edition of API Std 2000.

The tank Vendor shall coordinate the complete design and supply of all the tanks and ensure the satisfactory performance of components supplied by Sub-Vendors. Where the Vendor provides components / equipment that he has not manufactured, he shall ensure that the items are compatible with all other components supplied. The Vendor shall be responsible for guaranteeing all equipment / components including those supplied by Sub-Vendor, if any.

 <b>ONGC</b> ॐ नमो भगवते वासुदेवाय <b>MRPL</b>	<b>MRPL Marketing Terminal Project at Devangonhi, Bangalore</b> <b>Marketing Infrastructure Projects, MRPL</b>		Page 213 of 269		 <b>nauvata</b> ENGINEERING & CONSULTING
	Part – C	<b>SPECIFICATION</b>  <b>FOR TANKS</b>	Tender No. :	3200000495	
	Section – C-3		Doc No.:	20005-GEN-M-SPE-4005	
Subsection – C-3.10	Rev :		1		

### 9.2. Design Life, Reliability and Maintenance

The equipment and their components shall be designed and constructed for a design life of 25 years. Equipment components should be of a proven design for reliability and minimum maintenance.

The Contractor / Vendor shall supply all the equipment with proper design, workmanship and quality to meet all the specified design and operating conditions. Sole responsibility rests with Contractor / Vendor for safe and reliable operation of equipment throughout the design life.

### 9.3. Corrosion Allowance

The minimum corrosion allowance (CA) for tanks shall be as specified in the individual tank mechanical datasheets. A minimum corrosion allowance of 1.5 mm shall be provided for carbon steel shell, bottoms, Floating roofs and all welded components, even if tank internally coated unless otherwise specified. (Bottom Shell course and Bottom Plate 3.0 mm CA as shown in data sheets.) Self supported roof plates shall have CA is 1.0 mm

Corrosion allowance for shell, floor, supported roof & structural members shall be applied according to API Std 650. Corrosion allowance for nozzles, manholes & self-supporting roofs shall be added to the design thickness. The resulting thickness shall in no case be less than the minimum nominal thickness required by API Std 650.



Corrosion Allowance (typ. 3 mm) on anchor bolts shall be applied to the nominal diameter, for tank requiring anchorage. Corrosion allowance for anchor straps shall be added to the required strap thickness. For internal structural, the corrosion allowance shall be applied to each exposed surface unless otherwise specified. Removable internals shall have half the specified corrosion allowance applied to all surfaces exposed to the process fluid.

No corrosion allowance is required on stainless steel materials or materials protected by stainless steel unless otherwise specified. (Refer also data sheets)

### 9.4. Design Loads

Tank shall be designed for the combined loads applicable to operation, shutdown and test conditions. These shall, as a minimum, include loads due to;

- Dead loads, i.e. the loads resulting from weight of tank plus all attachments (viz. ladders, stairs, platforms etc.)
- Live loads (as per Datasheet or Code whichever is higher)
- Insulation loading if applicable.
- Contents
- Internal Operating Pressure or Vacuum.
- Hydrostatic Test Pressure.
- Wind loads.
- Seismic loads.
- Piping External Load
- Thermal Loads (Appendix M of API 650)

	<b>MRPL Marketing Terminal Project at Devangonhi, Bangalore</b> <b>Marketing Infrastructure Projects, MRPL</b>		Page 214 of 269		
	Part – C	<b>SPECIFICATION</b>  <b>FOR TANKS</b>	Tender No. :	3200000495	
	Section – C-3		Doc No.:	20005-GEN-M-SPE-4005	
Subsection – C-3.10	Rev :		1		

- Rainfall loads
- Foam loads

Uplift is also caused by the internal vapour pressure acting against the underside of the roof, in conjunction with wind load. A stability calculation shall be made to determine the number of anchor bolts required, including embedment depth.

#### Wind Loads

Tank shall be designed for wind load as per API Std 650. Wind code and wind pressure shall be considered as per the Environmental data provided in project design basis. Generally, ASCE shall be used for wind design unless otherwise specified.

#### Seismic Loads

Tank shall be designed for seismic load as per API Std 650, Appendix E. Seismic design code and seismic data shall be considered as per the Environmental data provided in project design basis. Generally, UBC shall be used for seismic design unless otherwise specified. (As per IS-1893 Part 4 Bangalore is classified in Zone 2 with a Seismic factor of 0.1.)

The Manufacturer shall submit his calculations for seismic design to the Purchaser for approval. Sloshing of floating roof, if applicable, shall not damage internals including floating roof itself during earth quake.

#### Rainfall Load

Rain fall load considered, if specified in mechanical datasheet.

Wind and earthquake shall not be applied simultaneously.



Overturning and sliding stability and the need for anchor bolts shall be based on the empty tank in corroded condition.

### **9.5. Bottom Plates & Annular Plates**

The tank bottom shall be sloped in accordance with the individual tank Mechanical Data sheet. All lap joints in bottom plates shall be fully fillet welded on the top side only and weld shall be with minimum two (2) passes. The minimum lap shall be five times the thickness of the plate.

Annular bottom plate shall be provided for the tanks, if required. Annular plates shall be same material and heat treatment, and shall conform to same impact properties as the bottom course to which annular plate are welded. Annular plate shall have a minimum width of 600 mm at any point and minimum lap between the bottom and annular plates shall be 65 mm. Annular plate shall be butt welded, if lowest shell course hydrostatic test stress is 171 MPa (24900 psi) or greater irrespective of material used. Annular plate thickness shall be of API Std 650 Table 5-1a.

Drain sump shall be located so as to clear any lap joints in the tank bottom or annular plate. The lap shall be so arranged to shed the water towards drain.

	<b>MRPL Marketing Terminal Project at Devangonhi, Bangalore</b>		Page 215 of 269		
	<b>Marketing Infrastructure Projects, MRPL</b>		Tender No. :	3200000495	
	Part – C	<b>SPECIFICATION</b>	Doc No.:	20005-GEN-M-SPE-4005	
Section – C-3	Rev :		1		
Subsection – C-3.10	<b>FOR TANKS</b>				

Pipe supports, floating roof leg supports and other internal fixtures that are supported off tank bottom shall rest on circular wear pad that is seal welded to bottom plate.

The connection between the lowest shell course and annular plate shall be continuous fillet on both sides.

#### 9.6. Shell Design

Allowable Stress of IS 2062 materials shall be calculated based on formulas given in API.

No shell course shall have a thickness less than that of the course above, regardless of the material of construction.

Calculation for intermediate wind girders for tanks where the shell corrosion allowance exceed 1.5 mm shall be based on nominal shell thickness minus corrosion allowance.

All horizontal and vertical joints in shell plates shall have full penetration and full fusion welds. Single side butt welds are not permitted. All shell seams shall be butt welded from both sides of the plate.

In single-vee or single-bevel butt joints, the vee or bevel shall be made on the outside of the tank, unless otherwise specified. The reverse side of double butt welds shall be back chipped or ground to sound metal before welding.

First shell course plates shall be arranged so that the vertical joints clear the annular ring welds or sketch plate welds by at least 300mm. Vertical joints of the shell courses shall also clear the nozzle attachment welds or reinforcement pad welds as per API-650 and applicable appendix.

Shell plates shall be suitably stiffened for the local loads on nozzles and on piping / structural clips to prevent local buckling of shell. The stiffening arrangement shall be such as to distribute the load to a larger shell area or to transfer the load to a thicker shell. A finite element analysis is required to establish that the proposed stiffening arrangement is adequate, if the same cannot be accessed analytically.



Tanks subject to external pressure above 25 kPa shall be analysed in accordance with API Std 650 Appendix V, Design of Storage Tanks for External Pressure.

When aluminium dome roof is specified in data sheet, tank shall be designed as an open top tank and its wind girder shall meet the requirement of API Std 650 clause 5.9, Top and Intermediate Stiffening Rings (Wind Girders).

When the shell courses are of various thickness, they shall be aligned in a way such that internal diameter of tank is kept constant. Nominal tank diameter shall be the inside diameter of the tank.

#### 9.7. Shell Openings

The number and sizes of nozzles shall be governed by the process requirements for individual tanks. All nozzles, except manways, shall have minimum class 150# flanges. Flanges for 24" NB nozzles and smaller shall conform to ASME B16.5. Flanges larger than 24" NB shall be to ASME B16.47 Series B.

	<b>MRPL Marketing Terminal Project at Devangonhi, Bangalore</b>		Page 216 of 269		
	<b>Marketing Infrastructure Projects, MRPL</b>		Tender No. :	3200000495	
	Part – C	<b>SPECIFICATION</b>	Doc No.:	20005-GEN-M-SPE-4005	
Section – C-3	Rev :		1		
Subsection – C-3.10	<b>FOR TANKS</b>				

Minimum wall thicknesses of carbon steel nozzle necks including corrosion allowance shall as per API Std 650 / project specifications.

The minimum nozzle projections from the outside of the tank wall to the face of flange shall be as per Table 5.6 of API Std 650. However, for top nozzles, projection may have to be increased to clear platform, if required. This shall be specified in nozzle orientation drawing.

As a minimum one roof manway and one shell manway shall be provided on the storage tanks.

Nozzle flanges shall be raised face unless otherwise shown on the individual data sheets and/or drawings. Flanges for shell and roof manways shall conform to clause 5.7 & 5.8 of API Std 650.

All stud bolts shall be fully threaded. Threads shall be UNC series for stud bolts up to and including 1"dia & UN8 series for higher sizes. Internal bolting shall be compatible with the contacting fluid.

Storage tank in dirty service (e.g. liquid sulphur, bitumen or crude) shall have minimum one (1) flush type clean-out door. If the manway cover / clean out door cover exceeds 25kg in weight a davit shall be provided.

In all earthen foundations, Method A of API 650 Figure 5-13 shall be used. In all such cases the Vendor shall be responsible for the supply and installation of the bulkhead plate and in all instances the bulkhead plate shall be welded to the bottom reinforcing plate. Thickness of bulkhead plate shall be 12 mm minimum. In all concrete ring wall foundations, Method C of shall be used, unless otherwise specified. Gasket material 'CNAF' to be used for cleanout door cover.

The tank vendor shall provide the following API Std 650, Appendix P information for bottom shell course nozzles DN 150 (NPS 6) and larger.

- Nozzle rotations, deflections and stiffness coefficients.
- Nomograms of the allowable loads (see API Std 650)

For nozzles other than those noted above, the piping designer is responsible for the Appendix P analysis.



Pipes connected to the nozzles of tank shells shall be designed in such a way that no significant bending moments or loads act on the nozzle. The settlement of the tank, the outward movement of the shell and the inclination of nozzle under full hydrostatic load shall be taken into account. For nozzles DN 500 (NPS 20) and more in diameter the use of bellow and balanced supports should be considered. Large size shell nozzle connections (e.g.> DN 500 (NPS 20) in diameter) may influence the lowest position of the floating roof and increase the 'dead stock'. In such a case two smaller shell nozzles should be used in order to reduce the 'dead stock'.

#### 9.8. Stiffening Ring, Curb Angles and Compression Rings

Radial joints in the curb angles, compression rings and stiffening rings shall not align with the vertical joints in shell and shall be at least 150 mm away from the shell vertical joints.

Stiffening rings shall be provided with drain holes of 25 mm diameter at maximum 2400 mm spacing.



	<b>MRPL Marketing Terminal Project at Devangonhi, Bangalore</b> <b>Marketing Infrastructure Projects, MRPL</b>		Page 217 of 269		
	Part – C	<b>SPECIFICATION</b>  <b>FOR TANKS</b>	Tender No. :	3200000495	
	Section – C-3		Doc No.:	20005-GEN-M-SPE-4005	
Subsection – C-3.10	Rev :		1		

Stiffening rings shall be attached to the shell with a continuous fillet weld at the top side and a seal weld at bottom.

Hand railing shall be provided all around the top stiffening ring / wind girder when it is used as a walkway on external floating roof tanks & open top tanks.

The curb angle at the top of the shell shall be lap or butt welded to the top course with flange turned outside. The size of the curb angle shall be as specified in code. A smaller sized curb angle may be used when so required for making the roof to shell joint frangible. The roof to shell junction shall be checked for the radial load imposed from the roof supporting structure.

For Tanks with internal pressure, the participating area of the compression ring based on the corroded thickness of shell and roof shall be more than the required compression ring area calculated using the code rules. The failure pressure shall be calculated on the basis of the participating area of the compression ring using as-built thickness of the roof and shell.

Where the roof to shell junction is not frangible, the frangibility pressure shall be calculated on the basis of the participating area of the compression ring using as-built thickness of the roof and shell.

### 9.9. Roof Design

Roof selection of tanks shall be based on the volatile emissions and process fluid handled in the tank. Type of roof shall be indicated in the datasheets.

#### 9.9.1. Fixed roof

Fixed roof shall be self-supported type or supported type and shall be generally conical roof unless otherwise specified. Supported roof shall be of structure supported type, fixed cone design. Roof support arrangement shall be indicated in the individual tank Mechanical Data sheet.



The roof and the supporting structures shall be designed to carry the minimum loads and the lateral loads as specified in API Std 650 and applicable specifications.

The fixed roof tanks shall be freely vented and shall be frangible as defined in API Std 650. If roof joints are not frangible, then emergency vents shall be considered for oil and hydrocarbon tanks.

Vents for fixed roof tanks shall be sized in accordance with API Std 2000. Flame arresters shall not be supplied unless specified in datasheets. All the tank vents, including those on internal floating roof tanks, shall be screened with coarse mesh stainless steel screen. Tank vents shall not be located closer to stair or platforms.

Where an internal coating for fixed carbon steel roof would be required, one of the following shall be used.

- A steel roof with any support members being external, usually a dome or umbrella roof. Roof plates shall be fillet welded on both sides or butt welded. Any support members shall be continuously welded to roof and have drain slots.
- An Aluminium dome roof, if appropriate to resist the corrosive condensation anticipated.

	<b>MRPL Marketing Terminal Project at Devangonhi, Bangalore</b>		Page 218 of 269		
	<b>Marketing Infrastructure Projects, MRPL</b>		Tender No. :	3200000495	
	Part – C	<b>SPECIFICATION</b>	Doc No.:	20005-GEN-M-SPE-4005	
Section – C-3	Rev :		1		
Subsection – C-3.10	<b>FOR TANKS</b>				

Roof plates shall be joined at the top by continuous full fillet welds. Laps shall be arranged with lower edge of the upper plate underneath the upper edge of the lower plate. On the bottom side, where flexure can be anticipated adjacent to roof stiffening members, clips or nozzles with large piping loads, full fillet welds not less than 50 mm long on 250 mm centre shall be used on any plate lap joint that occur within 300 mm of any such member. A minimum of three fillet welds shall be made.

Roof plates of supported roof shall not be welded to the internal roof structure, unless otherwise specified in the datasheet. However, stiffened roofs to be welded to external roof structures. Hand railing shall be provided all around the roof for fixed roof tanks.

The loads from piping / structural clips on the roof plate shall be transferred to the roof structure by providing supporting beams connected to the roof structure underneath the roof plate.

Manholes shall be of circular cross section and 600 mm in diameter, unless otherwise specified by Purchaser. Manholes shall be as per API 650; All manholes shall have a hinge arrangement for manhole cover removal without any obstructions.

#### 9.9.2. Internal Floating Roof

Internal floating roof shall confirm to API Std 650, Appendix H. Following types of internal floating roof are acceptable; however, type of roof shall be as indicated in respective datasheets.

- ~~Full contact Aluminium sandwich-panel/composite roof (Honeycomb panel)~~ Pontoon Type, Single Deck



All internal floating roofs shall include buoyancy required to support at least twice its dead weight (including the weight of the flotation compartments, seal and all other floating roof and attached components), plus additional buoyancy to offset the calculated friction exerted by peripheral and penetration seals during filling at the lowest expected specific gravity, which shall not be more than 0.7 under conditions given in API Std 650 Appendix H. The design shall also cater for foam hold up near the seal area. Vendor shall provide suitable arrangement for holding the foam.

All internal floating roofs with multiple floatation compartments shall be capable of floating without additional damage after any two compartments are punctured and flooded. Designs which employ an open centre deck in contact with the liquid shall be capable of floating without additional damage after any two compartments and the centre deck are punctured and flooded.

The roof shall be designed to withstand the effects of a maximum fill rate equal to twice the fill rate specified in the data sheet.

The floating roof shall be capable of withstanding internal blending operations using Nitrogen or internal jet nozzle / eductor systems. Vendor shall request and obtain any information required from Purchaser on this regard.

Adequate means shall be provided to prevent electrical charge on the floating roof causing sparking in or above the seal. Shunts shall be provided on secondary seals, at maximum spacing of 3 meters. Shunts shall be of austenitic stainless steel 50wide x 0.4thk x 400lg. All conductive parts of the internal



	<b>MRPL Marketing Terminal Project at Devangonhi, Bangalore</b> <b>Marketing Infrastructure Projects, MRPL</b>		Page 219 of 269		
	Part – C	<b>SPECIFICATION</b>  <b>FOR TANKS</b>	Tender No. :	3200000495	
	Section – C-3		Doc No.:	20005-GEN-M-SPE-4005	
Subsection – C-3.10	Rev :		1		

floating roof shall be electrically interconnected and bonded to the outer tank structure by cables from the external tank roof to the internal floating roof.

Internal floating roof component that are fabricated or attached by welding shall be completely seal welded.

Following requirements shall be considered for design and construction Aluminium floating roof in addition to above.

- Aluminium floating roofs shall be full contact type with minimum vapor spacing between floating roof and project surface. Also type of roof shall be selected considering minimum vapor emission.
- Roof and accessories shall be so designed as to allow roof to operate throughout its normal travel without manual attention without damage to any part of tank or floating roof. Roof shall float and rest reasonably horizontal pattern.
- The floating roof shall be naturally buoyant to support at least twice the weight of roof and accessories, plus additional buoyancy to offset the calculated friction exerted by peripheral and penetration seals and shall not sink if punctured anywhere. Buoyancy shall be based on a product specific gravity of 0.7 or actual specific gravity if less than 0.7
- The floating roof shall have considerable excess floatation as well as structural rigidity to allow 2 persons (total wt. 500 lbs per sq. feet) to walk side-by-side anywhere on the roof without damaging or allowing product on the roof.
- Floating roof structures and panels are to be designed to ensure that all stresses fall within the allowable limits for the material used when subjected to a uniform load of 500 psf anywhere on the surface while floating or when suspended and receiving no buoyancy from the panels.
- The roof shall have sufficient rigidity to permit provision of peripheral primary mechanical shoe seal and secondary wiper seal. Module design shall such that it shall maximize the strength, stiffness and durability. Minimize evaporation loss through the joints.
- The roof design shall prevent retention of product on top surface. Drains provided shall extend at least 100mm into the product.
- The floating roof design shall incorporate anti-rotation system with cable and guide.
- The floating roof shall incorporate standard accessories such as Manways, Gauging nozzles, pressure vacuum vents etc.
- Roof design shall be such that there are no hidden pockets for absorption/retention of vapour/product during degassing. Each closed flotation compartment shall be capable of being field-inspected for the presence of combustible gas. Closed compartments shall be capable of being resealed in the field after periodic inspection (to prevent liquid or vapour entry). Vendor's Operating and Maintenance Manual shall give guidelines and training in this regard.
- Where tank mixers are installed, the roof shall be designed for operation of a tank mixer at the low pump-out level. For the calculation, the Vendor shall assume:
  - 7.5 kW (10hp) in tanks less than 12 m (40ft) in diameter
  - 18.7 kW (25hp) in tanks between 12 m and 30.5 m (100ft) in diameter

	<b>MRPL Marketing Terminal Project at Devangonhi, Bangalore</b> <b>Marketing Infrastructure Projects, MRPL</b>		Page 220 of 269		
	Part – C	<b>SPECIFICATION</b>  <b>FOR TANKS</b>	Tender No. :	3200000495	
	Section – C-3		Doc No.:	20005-GEN-M-SPE-4005	
Subsection – C-3.10	Rev :		1		

- 30 kW (40hp) for tanks over 30.5 m in diameter.

### 9.9.3. Floating Roof Accessories

#### 9.9.3.1. Roof seals

Space in between the outer periphery of the floating roof and the tank shell shall be sealed by approved sealing devices consisting of double seal arrangement with a Primary seal and secondary seal. Peripheral seals and other seals shall be designed remain in full contact with mating tank components throughout the entire travel span for floating roof.

Double seal arrangement shall be either a mechanical shoe with a secondary wiper seal, foam seal with secondary wiper seal or a double wiper seal. Selection of seal material shall be based on operating conditions. Recommended seal material shall be sufficiently resilient under operating conditions to maintain good contact and will not deteriorate under prolonged exposure to the product or its vapours.

Sealing device material shall be resistant to withstand product to be stored in the tank and also durable against friction due to roof movement. At the same time the sealing system shall exert sufficient sealing pressure in all directions to prevent any evaporation leaks.

Primary Mechanical shoe shall be of SS 316 material with 1.2 mm minimum thickness with 100% aromatic-resistant fabric seal. Secondary wiper seal shall be with compression plate of SS 316 material with polymer seal tips.

The seals shall be installed and maintained from the top side of the floating roof and design should permit installation or maintenance while the tank is in service. Secondary seal shall permit inspection of primary seal without removal and the seals shall be designed to deflect sand or other debris back on the roof.

Stainless steel shunts shall be provided for earthing of the floating roof across the rim space at a maximum interval of 3 meters. The sliding contact with the shell shall be in the open air above the secondary seal.



The Sealing material shall be guaranteed for its durability / satisfactory performance for a minimum life period of four (4) years.

If Wax scrappers are specified in datasheets, they shall be located such that the scrapping action occurs below the liquid surface. Design of wax scrappers shall not interface with shell accessories when roof at lowest position.

Vendor shall specify and provide information for type of seal & configuration, seal Vendor etc. with their Tender. Seal Vendor and the seal design shall be approved by Purchaser.

#### 9.9.3.2. Roof penetrations & nozzles

Roof penetration shall be provided as indicated in respective datasheets; however as minimum following nozzles & penetrations shall be provided all the internal floating roof tanks.

	<b>MRPL Marketing Terminal Project at Devangonhi, Bangalore</b>		Page 221 of 269		
	<b>Marketing Infrastructure Projects, MRPL</b>		Tender No. :	3200000495	
	Part – C	<b>SPECIFICATION</b>	Doc No.:	20005-GEN-M-SPE-4005	
Section – C-3	Rev :		1		
Subsection – C-3.10	<b>FOR TANKS</b>				

Columns, ladders and other rigid vertical appurtenances that penetrate the floating roof shall have vapour seal provided which will permit a local deviation of +/- 127mm. A rim shall be provided around the floating roof periphery and shall extend 150 mm minimum above the liquid to contain product turbulence. Columns, ladders and other openings shall extend 150 mm above the liquid.

Each roof shall be equipped with auto bleeder vents, designed to open automatically when the roof lowers to 75mm its lowest operating position or lower leg setting, and to close automatically when the roof raises more than 75mm above its lowest position.

Floating roof shall be equipped with a vent or vents to prevent overstressing of the floating roof or seal. It shall be open during filling and emptying to evacuate air and gases underneath of roof or to release of vacuum during emptying and it shall not open while roof is floating due to pressure or vacuum. These vents shall be pressure/vacuum relief valve of approved make and Vendor shall size the vents based on maximum filling and emptying rate specified in datasheets.

Also, tank circulation vent shall be provided if specified in the datasheets. These vents shall be also be used as emergency overflow slots and shall conform to the requirements of H5.2.2 & H5.3.3 of API STD 650 Appendix H. These vents shall be provided at maximum spacing around 10 mtr. (32 ft) but in no case shall there be less than four equally spaced vents. Total open area of these vents shall be equal to or greater than 0.06 m<sup>2</sup>/m of tank diameter. Vents shall be covered with rain hood and coarse screen.

A gauge hatch, spark proof type with quick opening cover and fireproof gaskets shall be provided on fixed roof of Tank. Still well with perforations as indicated shall be provided and shall pass through the IFR and this shall also act as anti-rotation device shall extend up to the bottom and shall be maintained in perfect verticality. IFR shall be provided with sealed opening for the Stillwell of gauge hatch.



Gauge well pipes, Level indicator still well, landing legs and the other facilities which penetrate the deck shall be provided with sealing arrangements to limit emissions. Socks/ sleeves shall be custom designed self-adjusting type that can be easily retrofitted on existing gauge poles and landing legs while in service. Material shall be 100% compatible, non-corrosive while handling petroleum hydrocarbons and shall be of minimum 0.4 mm thick.

Internal floating roof deck shall be provided with at least one NPS 24 or larger manhole for access to and for ventilation when tank is empty and supported on its supports. If Pontoon design is used each pontoon shall provide with inspection opening / manhole with bolted cover for each compartment shall be design & supplied by Vendor.

### 9.9.3.3. Floating suction

Floating suction shall be provided, if specified in the datasheets.

Floating suction system shall be provided where there is a need to draw off product from just below the surface of liquids stored in bulk. This shall be normally provided for all aviation grade fluid tanks, where a high-quality product, free of water and sediment is required.

	<b>MRPL Marketing Terminal Project at Devangonhi, Bangalore</b>		Page 222 of 269		
	<b>Marketing Infrastructure Projects, MRPL</b>		Tender No. :	3200000495	
	Part – C	<b>SPECIFICATION</b>	Doc No.:	20005-GEN-M-SPE-4005	
Section – C-3	Rev :		1		
Subsection – C-3.10	<b>FOR TANKS</b>				

Floating suction shall be in sections and each section shall be removable through manhole. Manhole shall be suitably sized for the same.

- a) Floating suction shall be of made of Aluminium and having VITON / equivalent seal material as approved by Purchaser for swivel joints. Use of other materials is not acceptable without prior approval from Purchaser.
- b) Lubricant, if used, shall not contaminate the product to be stored in the tank.
- c) Suction nozzle shall be arranged in such a manner that the product is sucked without vortex, with full pipe flow and at lower velocity. Proper suction shall be ensured through the floating suction at any level of operation (at extreme positions as well as during the movement). The arrangement shall be in such a manner that the floating suction movement will not damage any part of the tank internal including the floating suction itself.
- d) External floating indicator shall be provided near tank outlet nozzle to know the level of suction from tank outside.
- e) All parts of floating suction shall be electrically bonded for electrical continuity. The electrical resistance between extreme points or between two points of the floating suction shall be within acceptable criteria stipulated by international standards / practices for the intended service of product to be handled.



#### 9.9.3.4. Floating roof support legs

The roof support shall be designed such that the roof when it rests in its support legs at lowest or highest position, it shall not deform the tank bottom or roof. The number of supports shall be sufficient to ensure non-deformity of the roof and tank bottom when the roof is resting on the legs. Also supports shall be designed such that it shall prevent damage to fixed roof and floating roof when tank is in overflow position.

Supports shall be designed for the high level (maintenance level of min. 2 m from tank bottom) and for the low level (minimum operating level). Minimum operating level shall be based lowest roof position permitted by internal components such as shell nozzle, nozzle projections, jet mixers or propeller mixers etc. a minimum clearance of 75 mm shall be allowed between the roof seal and any internal component.

Supports shall be fabricated from pipes unless cable or other type is specified in datasheet. The pipe supports shall be provided with cotter pins suitable for two level operations. For this, holes shall be provided on the top portion of the legs to adjust the cotter pin. Corrosion allowance shall be provided for roof supporting pipes and sleeves also.

If Cable supports are specified, cable supports shall be adjustable externally from fixed roof and shall not have an open penetration at floating roof surface, proper sealing shall be provided. Also fixed roof shall be designed and verified for cable support loads.

	<b>MRPL Marketing Terminal Project at Devangonhi, Bangalore</b>		Page 223 of 269		
	<b>Marketing Infrastructure Projects, MRPL</b>		Tender No. :	3200000495	
	Part – C	<b>SPECIFICATION</b>	Doc No.:	20005-GEN-M-SPE-4005	
Section – C-3	Rev :		1		
Subsection – C-3.10	<b>FOR TANKS</b>				

Changing low/high position must be accomplished from topside of floating roof and while tank is in service. In addition, legs shall be completely removable from top side of floating roof, while tank is in service if required.

For buckling design considerations of pipe support the effective length of pipe supports shall be taken as 1.5 times actual length of pipe support in maintenance position.

Bearing plates shall be provided on the tank bottom, centrally placed beneath each floating roof support. Bearing plates shall be 600mm diameter or square by 10mm thick, attached to the tank bottom by 5mm continuous fillet welds.

Pipe sleeve shall project sufficiently above the roof to take care of the flooded condition of the roof.

The projection of sleeve below the roof shall be 75 mm minimum to provide a vapour seal.

The length of the leg supports shall be re-adjusted at site by the Vendor after hydro-test of the tank so as to take care of the initial settlement of the tank bottom.

The base of the legs shall be designed so that no undue wear can occur on the tank base. Design shall include adequate drainage of the legs.

#### 9.9.3.5. Earthing (grounding)

The floating roof shall be electrically bonded to tank. This shall be accomplished with flexible cables from the tank roof to floating roof (minimum two, uniformly distributed). They shall be normally 1/8 inch diameter stainless steel aircraft cable or equivalent to ensure the strength, corrosion resistance, joint reliability, and service life.

All conductive parts of the internal floating roof shall be electrically interconnected and bonded to the outer tank structure by cables from the external tank roof to the internal floating roof. The entire contact surface shall be continuously conductive electrically expect for the perimeter seal to minimize the chance of static charges building up to sparking potential.



#### 9.9.3.6. Anti-rotation and Centering Devices

Internal floating roof shall be cantered and restrained from rotating. A Guide pole with rollers, two or more seal cantering cables or other suitable device shall be provided.

Gauge polls or still wells may be used as anti-rotation device. If more still wells are required, these shall be clubbed together in a casing pipe so that the total number of pipes passing through the floating roof is not more than two.

When still wells are used as anti-rotation device, roof shall be provided with rollers on either side of the still wells to keep the still well at the centre of the opening and to facilitate smooth movement of the roof.

For aluminium floating roofs anti-rotation device shall be provided by means of two (2) or more vertical cables firmly fixed to the tank roof and bottom. The cables shall pass through a stainless bushing mounted in the floating roof. The cables shall be minimum ¼-inch (6 mm) diameter stainless steel

 <b>ONGC</b> ॐ नमो भगवते वासुदेवाय <b>MRPL</b>	<b>MRPL Marketing Terminal Project at Devangonhi, Bangalore</b>		Page 224 of 269		 <b>nauvata</b> ENGINEERING & PROJECT MANAGEMENT
	<b>Marketing Infrastructure Projects, MRPL</b>		Tender No. :	3200000495	
	Part – C	<b>SPECIFICATION</b>  <b>FOR TANKS</b>	Doc No.:	20005-GEN-M-SPE-4005	
Section – C-3	Rev :		1		
Subsection – C-3.10					

aircraft type and made taut by means of a turnbuckle or spring arrangement. All cable fittings shall be type 304 or 316 stainless steel. Additional systems can be added for high turbulence applications.

#### 9.9.3.7. Foam Dams and Foam Chambers

Floating roofs shall be equipped with foam dams and chambers. Foam dams and chambers shall be designed in accordance with NFPA 11. Foam dams shall be adequately sealed to the roof with slots for drainage, as per NFPA 11.

The bottom of the foam dam shall be continuously welded to the roof upper deck plate. The dam shall be suitably braced at intervals of not greater than 5 m. The bracing shall extend radially towards the centre of the roof.

Provision shall be made for the attachment of linear heat detection supports.

The foam chamber height shall be at least 50 mm above the tip of the secondary seals.

#### 9.10. Wind Girders

Wind girder computations shall be provided according to API STD 650 Sections 5.9 for all tanks. Intermediate wind girders shall be provided if the calculations indicate the need. When a corrosion allowance is given, the corroded shell thickness shall be used in the calculations.

Primary wind girder shall be provided for all open top and external floating roof tanks.

When aluminium dome roof is specified in data sheet, tank shall be designed as an open top tank and its wind girder shall meet the requirement of API STD 650 clause 5.9.

It is to be evaluated whether temporary / additional stiffening rings may need during construction and avoid damage due to high winds (during construction stage).

#### 9.11. Internal Attachments



The tank Vendor shall furnish vortex breakers (in outlet nozzles), piping and other internals as required by the drawings and data sheets. Internal piping including dip pipes shall be flanged for ease of removal through tank manholes. Where inlet diffusers are specified on the inlet nozzles, these shall be sized to reduce inlet velocity to one meter per second (1m/s) at the outlet of the diffuser.

All removable internals shall be fabricated to pass through tank manholes. All internal and external attachments to the tank shall be continuously/seal welded.

Storage tanks to be provided with stilling well as indicated in the individual tank data sheet. Stilling well shall have equally spaced holes or slots over the entire height to prevent product stratification inside the well.

If specified in datasheet tank shall be provided with side entry mixers. Floating roof shall have sufficient (min. 75 mm) clearances from the propellers of mixer.



	<b>MRPL Marketing Terminal Project at Devangonhi, Bangalore</b> <b>Marketing Infrastructure Projects, MRPL</b>		Page 225 of 269		
	Part – C	<b>SPECIFICATION</b>  <b>FOR TANKS</b>	Tender No. :	3200000495	
	Section – C-3		Doc No.:	20005-GEN-M-SPE-4005	
Subsection – C-3.10	Rev :		1		

## 9.12. External Attachments

The tank Vendor shall furnish and attach all insulation supports, external pressure stiffeners, lifting lugs, stairways, ladder and platform clips, pipe supports, nameplates and earthing lug, unless otherwise specified. All attachments shall be continuously / seal welded.

The Vendor is responsible for the evaluation of local stresses at tank appurtenances and for providing sufficient reinforcement to avoid excessive stress levels.

Vendor shall provide clips for deluge pipe work on external shell surface. Also, provisions shall made for fabrication and installation of support brackets and hangers required for mounting of cable trays, electrical conduits, light fixtures and instrumentation hardware. These brackets shall be with circular wear pads.

### 9.12.1. Platforms, walkways and stairs

The operational fittings and accessories shall be provided as per data sheets. Design of these components shall be the Vendor's responsibility and shall be based upon sound structural principles substantiated by full calculations.

Tanks shall be provided with stairway, roof access and hand railing as indicated in the datasheets and the code. Angle of spiral stairways to the horizontal plane shall be maximum 45 °. Spiral stairways shall be provided for tank height more than 6 m with intermediate landings at every 5m height. Handrails shall be provided at the edge of the roof for the full circumference and outside of the spiral stairway. For smaller tanks vertical ladders with cage may be provided, if indicated in data sheet.

The handrail around the tank shall be suitable for a painter's trolley capable of supporting a total weight of 400 kgs between two vertical rail posts.



Spiral stairway shall be completely supported by the tank shell, and the ends of any stringers or supports shall terminate clear of the tank foundations. Stairway shall comprise of double stringers with non-skid treads and include intermediate landings. Stair treads shall in no case be directly welded on the tank shell. Stringer supports shall be welded to tanks with pads only.

Stairways and walkways shall be capable of supporting a superimposed live load of 5 KN/m<sup>2</sup> & 2.5 KN/m<sup>2</sup> or a concentrated load of 7.5 KN & 3 KN applied at any point respectively.

Handrails shall be constructed from carbon steel pipes. The distance between handrail uprights around the tank perimeter, on walkways, or along the slope of the stairway shall not exceed 1500 mm.

Unless otherwise specified, ladders extending more than 3000 mm above grade shall have cages above elevation 2300 mm and all ladders shall have safety gates. Rest platforms shall be provided at intervals not greater than 9000 mm. Ladders shall be oriented as side entry.

The minimum clear walking space on stairways and walkways shall be 800 mm. Minimum headroom clearance shall not be less than 2100mm. Walking surfaces shall be non-slip. Treads and landings shall have a distinctive non-slip nosing. Unless otherwise specified, external spiral stairways shall have landings at every 4000 mm of maximum riser 200 mm.

	<b>MRPL Marketing Terminal Project at Devangonhi, Bangalore</b>		Page 226 of 269		
	<b>Marketing Infrastructure Projects, MRPL</b>		Tender No. :	3200000495	
	Part – C	<b>SPECIFICATION</b>	Doc No.:	20005-GEN-M-SPE-4005	
Section – C-3	Rev :		1		
Subsection – C-3.10	<b>FOR TANKS</b>				

Tank Roof - Platform shall be provided for level gauge, sample hatch and instrumentation nozzles with access walkway to this platform from the top landing platform. Proper access shall be provided to manholes, vents and foam pourer nozzles, as applicable. Access walkway with handrails on either side to roof Centre shall be stairway (shall not be on anti-slippery pads or angle sections welded to roof plates). Minimum width of walkway shall be 900mm. There shall be platform with hand rails at roof Centre.

All burrs and sharp edges shall be removed from hand railing, ladders and cages.

Platforms, landings, stairways and railings shall be either hot dipped galvanized or painted with an approved protective coating for corrosion prevention.

#### 9.12.2. Tank Earthing

All tanks shall be fitted with earthing lugs. Required number is 3 for tanks up to 15m dia. and 4 for greater diameter.

For earthing of the tanks earthing pits will be made adjacent to the tanks. The tank shall be connected to the earthing pit by 50 x 6 mm thick MS galvanized strip.

All parts of the floating roof shall be electrically connected, i.e. earth bonded, to each other and the tank wall, in accordance with API-RP 2003 Recommended Practice for Protection against Ignition Arising out of Static, Lightning and Stray Currents.

#### 9.12.3. Miscellaneous

Central sump shall be provided as per data sheet and details per API 650.

Datum plate 6 mm thk shall be provided by welding to the tank bottom directly below the roof gauge hatch, dip hatch, level gauge with or without still well pipes

The water draw off and stripping lines shall extend to the centre of the centre sump and shall be flanged connections.



Settlement markers shall be provided at adequate intervals throughout the circumference of the tank as per API 650.

#### 9.12.4. Foam Tanks

The applicable code for two nos. Foam tanks shall be API 650 Annex S Austenitic Stainless-Steel Storage Tanks, and Good Engineering Practices.

To use min SS Plate thk 5 mm SA 240 TYP 304 Plate Material for shell and conical heads as per drawings.

All shell joints shall be butt-welded so that full penetration is produced without the use of back-up bars. Shell plates shall be sized to limit the number of plates to the smallest practical number consistent with sound economic practice. Each course should preferably be constructed of one plate. Joints in Bottom plate shall be avoided. All accessories as support legs, ladder, manholes shall be as per drg and data sheet. Structural members may be Carbon steel.

	<b>MRPL Marketing Terminal Project at Devangonhi, Bangalore</b> <b>Marketing Infrastructure Projects, MRPL</b>		Page 227 of 269		
	Part – C	<b>SPECIFICATION</b>  <b>FOR TANKS</b>	Tender No. :	3200000495	
	Section – C-3		Doc No.:	20005-GEN-M-SPE-4005	
Subsection – C-3.10	Rev :		1		

## 10. DESIGN REQUIREMENTS – HORIZONTAL TANKS

### 10.1. General

The three underground atmospheric type steel tanks one each for Slop, MS, and HSD are 2.75 m diam. x 13m long to be installed in a pit are to be designed as per IS 10987:1992 for below ground tanks as the pit is to be sand filled. The plate minimum thickness for shell and end plate shall be 8 mm and 10 mm for above ground tanks as per Table 1 of IS code.

Tanks covered by these requirements are cylindrical tanks that are fabricated, inspected, and tested for leakage before shipment from the factory as completely assembled vessels. OISD guidelines shall be applicable.

The total capacity of a tank shall not be:

- a) less than the rated nominal capacity and
- b) more than 105 percent of the rated nominal capacity.

The tank should be located in an RCC pit and shall be filled with sand.

A tank shall be constructed of commercial or structural grade carbon steel. Only new material shall be used.

### 10.2. Shell & End Plate Joints

Shell Joints shall be butt welded as per Fig 3A of IS code. ISI marked electrode of required size to be used for all fabrication & welding works.

The plates are to be assembled and retained in position for welding by some suitable methods. Tack welds, where used, are to be removed so that they do not become part of the main seam. Corrections of irregularities are not to be carried out by hammering.



All shell welds shall be butt welds with full penetration and minimum of double inside and outside beads. The end plate will be welded to the shell with two runs of fillet weld both from inside and outside (as shown in the drawing). However, One extra run of welding should be provided from outside, along the periphery of end plates, in addition to the said fillet weld.

Single pass welds are not permitted. Undercutting, overlapping at the toe or bad profile shall be avoided. While welding the metal at the bottom of the first side is to be removed by grinding, chipping, machining or other approved methods so as to provide clean sound metal to deposit the subsequent welds.

Each run of weld metal is to be thoroughly cleaned and all slag removed before the next run is deposited.

Joints shall be staggered to ensure no + joints formed on the shell.

Only one no. horizontal joint is allowed in the end plates and no vertical joints will be allowed in the end plates.

	<b>MRPL Marketing Terminal Project at Devangonhi, Bangalore</b> <b>Marketing Infrastructure Projects, MRPL</b>		Page 228 of 269		
	Part – C	<b>SPECIFICATION</b>  <b>FOR TANKS</b>	Tender No. :	3200000495	
	Section – C-3		Doc No.:	20005-GEN-M-SPE-4005	
Subsection – C-3.10	Rev :		1		

Manhole pad plate to be made out of single plate as per drawing. Longitudinal Joints in Shell Plates shall not appear below central line of Tanks.

### 10.3. Fittings

All Pipes & nozzles will conform to IS 1239, heavy class. SORF Flanges used for nozzle connections will be of plate type IS 2062, Gr. B suitable for class 150 pound per Sq. Inch with serration and dimensions as per ANSI B 16.5

All other fittings as per drawing shall conform to relevant spec mentioned in the drawings.

All Structural Steel will be as per IS 2062. In case of non-availability of any specific size of Structural Steel (viz. Angel, Section, Channel etc.) mentioned in the drawings, the fabricator will be allowed to use higher sizes of the same.

### 10.4. Nozzles and Reinforcing Pads / Pad Flanges

- a. Nozzles shall be fitted with flanges as indicated in the drawing.
- b. All nozzles 50 mm dia and above shall be provided with reinforcing as per the drawing. Reinforcing pads / pad flanges shall be fabricated in accordance with the details given in the drawing.
- c. Nozzle and their reinforcing plates shall not straddle shell welds. All weld accessories shall be at an adequate distance away from shell welds.
- d. Welding of nozzles to the shell shall be of same quality weld as the shell welding.
- e. Inside edge of the manhole shall be smooth with no sharp edges.
- f. Manhole cover plate & manhole flange (10mm thick) edge should be machine finished and bolt hole should be drilled of desire size.

### 10.5. Special Requirements - Corrosion Protection

Vendor shall propose systems for Corrosion Protection and leakage monitoring of these tanks as optional.

## 11. FABRICATION & WELDING REQUIREMENTS



### 11.1. Fabrication

Every shell plate shall be inspected for thickness. Six measurements are required, one at each former of the plate, and two at the Centre of the long sides. Measurements shall be taken immediately upon arrival of the plate at the construction site. Measurements shall be reported in writing showing a sketch, and both the plate and the sketch shall be marked for positive identification.

Prefabrication of various parts shall be carried out in vendor shop prior to delivery of material to site.

For site fabricated tank extent of shop fabrication shall be identified by tank Vendor. Small tanks shall be totally fabricated at vendor shop.

The tank fabrication and dimensional tolerances shall comply with Section 6 & clause 7.5 of API-Std 650. Nozzle location shall not deviate more than 6 mm vertically or horizontally from the positions shown on the data sheet.

	<b>MRPL Marketing Terminal Project at Devangonhi, Bangalore</b>			Page 229 of 269	
	<b>Marketing Infrastructure Projects, MRPL</b>				
	Part – C	<b>SPECIFICATION</b>  <b>FOR TANKS</b>	Tender No. :	3200000495	
	Section – C-3		Doc No.:	20005-GEN-M-SPE-4005	
Subsection – C-3.10	Rev :		1		

The deviation of flange faces from the normal plane shall not exceed 1deg for nozzles and 2 deg for manways.

No fabrication shall begin until the Vendor has received written approval of material certification, detailed fabrication drawings, calculations, weld procedures, plus welder performance and weld procedure qualifications from the PMC / Contractor

All reinforcing pads, backing plates and similar attachments shall fit closely to and conform to the curvature of the surfaces to which they are to be attached. The gap at all exposed edges of such attachments shall not exceed 1.5mm. The maximum gap between the outside surface of a nozzle/manway neck and the inside edge of the hole in either the shell/roof plate or reinforcing plate, through which the nozzle/manway is set, shall at no position be greater than 1.5mm.

The edges of plates may be sheared, machined or cut with a machine-operated gas torch. Shearing shall be limited to plates 10mm or less in thickness.

Curved edges of roof and bottom sketch plates and bottom annular plates shall be cut to shape in the workshop by mechanized gas cutting or machining.

The Vendor shall ensure that only the latest PMC / Contractor approved revision of documentation is issued to the fabrication shop.

Cutting and shaping of openings and weld preparations shall be carried out by machining, chipping, grinding or flame-cutting. Chipped surfaces which will not be covered with weld metal shall be ground smooth.

Shell plates shall be completely welded, checked for roundness and all fit-up scars and burrs removed prior to radiography.

Manways shall have internal welds ground smooth and inside corners rounded off.

On floating roof tanks, the internal weld surface shall be ground smooth to prevent damage to the rim seal.



All shell plates shall be rolled to the correct tank curvature. Shell plates for tanks smaller than 25m diameter shall have their ends pre-set to the proper curvature.

Shell plates shall be rolled in the same direction as the final roll given while manufacturing the plate. Main seams shall be located to avoid nozzles, attachment welds and reinforcing pads.

Frequent alignment checks shall be conducted during prefabrication to ensure correct alignment of components prior to shipment to site.

Internal flanges, where required, may be fabricated from plate of 12 mm minimum thickness with full-face gaskets.

The Vendor shall issue a detailed erection procedure for approval by the PMC / Contractor at least two months prior to commencement of work at site.

	<b>MRPL Marketing Terminal Project at Devangonhi, Bangalore</b>		Page 230 of 269		
	<b>Marketing Infrastructure Projects, MRPL</b>		Tender No. :	3200000495	
	Part – C	<b>SPECIFICATION</b>	Doc No.:	20005-GEN-M-SPE-4005	
Section – C-3	Rev :		1		
Subsection – C-3.10	<b>FOR TANKS</b>				

## 11.2. Erection

Bottom plates shall normally be lap welded. The procedure for joggling the lap welded bottom plate below the shell shall be submitted to PMC / Contractor for his approval before proceeding any welding on the bottom plate. Overlap shall not be less than 5 times the plate thickness unless otherwise specified. For sketch plate to annular plate overlap shall be as per code.

Annular plates shall be assembled by butt welding with backing strips and it shall be lap welded to the sketch plates. The radial joint shall be radiographed as specified.

For floating roof tank bottom bearing plates shall be centered under each support and welded to bottom by continuous fillet weld of size equivalent to plate thickness. Plates shall be 600 mm round and 10mm thick.

During erection, tanks shall be adequately safeguarded against distortion or damage due to wind pressure by the provision of suitable steel wire guys or braces.

A minimum of one guy wire every 7.5m of circumference shall be provided. These shall remain in place until welding of the shell plates and erection of the roof framing has been completed, or, for open top tanks, until the wind girder has been completed. No holes shall be made in shell plates for erection purposes.

The circles corresponding to the inside and outside curvatures of the bottom course shell plates shall be marked out on the periphery of the tank bottom plates and used in setting out the bottom course shell plates. Allowance shall be made for the contraction of the vertical joints during welding. The bottom course plates shall be plumbed and checked for circularity, and be held securely in position and locked together by metal clamps or other devices.



Before fully welding the vertical butt joints of the bottom course of shell plates, a final check shall be made to ensure that the alignment of the plates and the width of the gaps between them are such that any inaccuracies after welding will be within the tolerances specified herein. If the tolerances are expected to be exceeded, the plates shall be re-aligned before the final welding begins.

Vertical joints in bottom shell courses shall be at least 300 mm away from annular or bottom plate joint. Vertical joints in adjacent shell courses shall be offset from each other by a minimum 300 mm.

After the bottom course vertical butt joints have been welded, the bottom course ring shall be set to the circles previously marked out on the tank bottom plates and any discrepancies in radius and curvature taken up as equally as possible around the whole circumference of the tank.

For floating roof tanks, internal diameter shall be maintained at all shell courses and shall be flush with Inside surface. Internal shell weld seams shall be ground flush and even to allow proper movement of the roof. Bulges and dents shall be avoided and shell shall be in perfect plumb.

Care shall be taken to minimize lack of circularity or distortion between the top and bottom of the tank shell, whether due to welding or any other cause.

	<b>MRPL Marketing Terminal Project at Devangonhi, Bangalore</b> <b>Marketing Infrastructure Projects, MRPL</b>		Page 231 of 269		
	Part – C	<b>SPECIFICATION</b>  <b>FOR TANKS</b>	Tender No. :	3200000495	
	Section – C-3		Doc No.:	20005-GEN-M-SPE-4005	
Subsection – C-3.10	Rev :		1		

Before erection of the roof framing begins, the shell periphery shall be carefully checked for uneven settlement and any misalignment of the top of the shell shall be corrected before the roof members are positioned.

All welded connections such as but not limited to wind girders, pipe supports, foam clamp platform handrails, etc. shall be seal welded to avoid corrosion

Temporary supports for the erection of the roof framing shall never be removed until the erection of the main and secondary framing is complete.

When assembling roof sheets on the framing, unsymmetrical loadings shall be avoided and not more than three roof sheets shall be stacked at any one point.

The design strength of erection poles to be used for temporary support of the roof structure shall be checked by calculation for the maximum load to be carried. In particular the strength against buckling shall be checked.

### 11.3. Welding

Welding of steel plates and other structures and accessories shall be carried out in accordance with approved procedures by qualified welders / welding operators.

Only experienced and qualified welders shall be used for fabrication and erection. Vendor shall submit a list of qualified welders and the processes for which they have been qualified.

The Vendor is responsible for the welding done by welders employed by him. Tests required qualifying welding procedure and to qualify the welders and if, necessary re-qualification of welders and welding operators shall be conducted with the approval of the engineer-in-charge.



All welding shall be done with procedures and operators, which have been qualified in accordance with Section 9 of API Std 650. Prior to commencing any production welding, the Vendor shall submit proposed qualified welding procedures and weld details for the PMC / Contractor's review and approval for the welding activities in his scope.

Welding will not be permitted when the surfaces to be welded are wet, covered in ice or any foreign substance or during periods of high winds unless adequate protection and heating are provided.

All welding shall be performed in conditions recognised to produce sound welds. Where welding is to be carried out in the open-air adequate protection from adverse weather conditions shall be provided. Weld under cuts are not permitted.

All the weld bevels and weld surfaces shall be free of cracks, excessive porosity, slag inclusions and other defects indicative of poor workmanship.

The lower shell plates shall be connected to the annular plates or bottom plates by continuous fillet welds on both sides. The leg length of both fillet welds shall be equal to the thickness of the annular plate or bottom plate. However, when the shell plate thickness is less than that of the annular plate or

	<b>MRPL Marketing Terminal Project at Devangonhi, Bangalore</b>			Page 232 of 269	
	<b>Marketing Infrastructure Projects, MRPL</b>				
	Part – C	<b>SPECIFICATION</b>  <b>FOR TANKS</b>	Tender No. :	3200000495	
Section – C-3	Doc No.:		20005-GEN-M-SPE-4005		
Subsection – C-3.10	Rev :		1		

bottom plate, the leg length of each fillet weld shall not exceed the thickness of the shell plate by more than 1.5mm. Tack welds for shell to bottom fillet welds, if used, shall be removed prior to welding fillets.

Minimum shell to bottom fillet weld size shall be the same as the bottom annular plate thickness or bottom shell course thickness whichever is less. Throat thickness of all fillet welds shall be checked using a profile gauge.

The surfaces of butt welds shall be of regular contour and irregular particles on metal surfaces shall be dressed off. Those regions of welds which are to be subjected to radiography shall not contain surface irregularities of such a nature as to interfere with the interpretation of the radiographs. Where such irregularities are present, they shall be removed by local dressing of the surface of the weld.

Fillet welds for attachments shall be continuous on all sides. Wind girders shall be seal welded to the shell on the wind girder underside.

Where tanks are to be internally lined or coated, weld joints shall be smooth and free from sharp edges and corners. No welding shall be performed after internal coating of the tank.

Flux cored welding shall not be used without PMC / OWNER approval.

When impact testing of base material is required, production weld test plates shall be made tested and results reported to PMC prior to tank erection as follows:

- The test plates made shall represent the bottom-course, mid-course, and top-course vertical and horizontal weld seams.
- Each test plate shall be from one of the heats that produced the plates for the tank. It shall be welded in the field using the same qualified welding procedure, joint detail, number of weld layers, position, and consumables required for the tank joint.

Welding electrodes, automatic or manual, shall deposit a composition corresponding to the material being welded. Where applicable, electrodes shall meet AWS/ASME specifications.

Welding electrodes and other welding materials may be of any recognized brand approved by the PMC / Contractor. Fabricator shall furnish brand names of welding consumables to Engineer-in-Charge for approval. No welding shall be undertaken without approval of the welding procedure and welder qualification test by the Engineer-in-Charge.



Low hydrogen electrode shall be used for all butt welds on plates thickness larger than 12 mm for materials in Group I, II & III (of API Std 650) and for all thicknesses in other groups.

Low hydrogen electrodes shall be dried or baked at the temperature level and times specified by the Vendor, and shall be used within 8 hours when stored in heated quivers. Electrodes stored in quivers, but not used within the specified times, shall be re-baked in ovens prior to use.

The Vendor shall operate a procedure for maintaining proper control of welding consumables.

No electrodes shall be left lying around the site, or in workshops. Electrodes so left shall be scrapped.



	<b>MRPL Marketing Terminal Project at Devangonhi, Bangalore</b>		Page 233 of 269		
	<b>Marketing Infrastructure Projects, MRPL</b>		Tender No. :	3200000495	
	Part – C	<b>SPECIFICATION</b>	Doc No.:	20005-GEN-M-SPE-4005	
Section – C-3	Rev :		1		
Subsection – C-3.10	<b>FOR TANKS</b>				

The Vendor shall provide proof to the satisfaction of the Owner / Contractor's Inspector that the welder has been using the process for which he is qualified within the previous 6 months. If not, then the welder shall be re-qualified.

Any stress relieving of shell clean-out doors, manholes and fittings, the assembly shall be furnace relieved prior to installation. No local stress relieving is permitted for shell fittings.

## 12. INSPECTION & TESTING

### 12.1. General

The Vendor shall perform all the inspection and tests in accordance with approved written test procedures.

The materials, manufacture and testing of all tanks shall subject to inspection to the Inspector or agency appointed by Owner / Contractor at the stages desired by Owner / Contractor.

All the inspection shall be carried out in accordance with the relevant codes and requirements of this specification and approved Quality Assurance Plan.

Inspectors shall have free access to all workshops of the fabricator at all stages of the manufacture. They shall place at the disposal of the inspector all means and facilities necessary for the proper execution of the inspection. All means and facilities shall be safe and adequate. Copies of all approval / certificate for the above to be submitted to PMC / MRPL, as directed.

Tests shall be carried out in accordance with a test schedule in the works execution plan.

No witnessed testing shall take place until all the latest relevant drawings, technical specifications, certificates and completed data sheets have been issued to and approved by the Contractor / PMC.



Approval of the Owner shall in no way relieve the Contractor / Vendor of his responsibilities for proper execution of the work.

The Vendor shall complete all internal inspection and routine tests prior to inspection by the Contractor to ensure that the witnessed testing is not prolonged by fault finding and rectification.

Faults or unsatisfactory operations that result in abortive witness tests shall be rectified at the expense of the Vendor. Any expense incurred by the Contractor / Owner / PMC resulting from abortive tests will be chargeable to Vendor.

The Vendor shall have necessary test equipment, tools and facilities required to carry out all the tests satisfactorily. All test instruments shall be calibrated and copy of calibration certificates shall be provided.

Tank shall be subjected to stage wise inspection by inspector, which will be arranged by Owner/ Contractor. Vendor shall provide full support and free access to his works and that of Sub Vendors for the Inspector. All necessary certification on materials, shop test data, etc. shall be made available to

	<b>MRPL Marketing Terminal Project at Devangonhi, Bangalore</b>		Page 234 of 269		
	<b>Marketing Infrastructure Projects, MRPL</b>		Tender No. :	3200000495	
	Part – C	<b>SPECIFICATION</b>	Doc No.:	20005-GEN-M-SPE-4005	
Section – C-3	Rev :		1		
Subsection – C-3.10	<b>FOR TANKS</b>				

verify that the requirements of the purchase order are being met. The Quality Control plan, showing witness hold points and statutory/code surveillance points, shall be made available.

The PMC / Owner/ Contractor or his agent reserves the right to conduct visual and dimensional checks of tanks during manufacture to ensure compliance with the relevant data sheet, API Std 650 and specifications. PMC / Owner / Contractor's inspection may include witnessing such tests as called for in the code, e.g., non-destructive tests as applicable and hydrostatic test, verification of welder's qualifications, review of welding procedures, etc.

The approval of any work by the PMC / Owner / Contractor or his authorized representative and the release of tanks or tank components for shipment / commissioning shall in no way relieve the Vendor of his responsibility for compliance of this specification, applicable codes, and standards and approved drawings.

Prior to final inspection and hydrostatic test, the inside and outside of the tank shall be cleaned and free from all slag, loose scale, dirt, weld spatter, oil and debris.

#### 12.2. Non-Destructive Examination

Only experienced personnel qualified to a recognized certification scheme shall be employed for non-destructive examination and interpretation of results. NDE procedures shall be submitted for review prior to manufacture.

All tanks shall be examined in accordance with the requirements of API Std 650 and as specified in the data sheets. In addition, the following inspection requirements must be met:



All welds shall be 100% visually inspected by competent welding inspectors.

Radiographic examination of butt joints shall be in accordance with API Std 650 and the following supplemental requirements:

- Spot radiograph shall show 150 mm minimum weld length. The film for spot radiographs at junctions between vertical and horizontal joints shall be positioned with the greater length on vertical seam.
- For manually welded joints, radiographic inspection requirements shall apply to each welder
- For automatically welded horizontal joints, one spot radiograph shall be taken in the first 3m of weld after each setup of automatic welder.

Liquid penetration/DP tests wherever required, shall be carried out as per ASME Section V and acceptance criteria shall be ASME Section VIII, Division - I.

Nozzles, manway openings and reinforcing pads shall not intersect or cover a weld seam. If this cannot be avoided the requirements of API STD 650 Para 5.7.3 shall be followed with approval of PMC. Also, the covered area of the joint plus 1.5 times the diameter of opening each side shall be ground flush and 100% radiographed prior to fitting the pad.

	<b>MRPL Marketing Terminal Project at Devangonhi, Bangalore</b>		Page 235 of 269		
	<b>Marketing Infrastructure Projects, MRPL</b>		Tender No. :	3200000495	
	Part – C	<b>SPECIFICATION</b>	Doc No.:	20005-GEN-M-SPE-4005	
Section – C-3	Rev :		1		
Subsection – C-3.10	<b>FOR TANKS</b>				

Pipes for nozzles or internals shall be seamless. Welded plate necks may be used for nozzle and manways but shall be subject to full radiography.

All welds for brackets, lugs, structural steel, etc. shall be located so as to miss tank welds by a minimum distance between edges of welds of 150mm. Otherwise those welds to be covered shall be ground flush for a distance of 150mm either side of the attachment and radiographed prior to welding the attachment.

All lugs, nuts, clamps & other devices attached by welding to facilitate erection, shall be removed prior to final inspection and the plate surface ground smooth and checked for surface cracks, by magnetic particle inspection, before the application of any coating. No holes shall be made in either the bottom or shell plates for the purposes of erection.

All bottom plate joints & roof plate joints tested using vacuum test equipment with a vacuum of 35 to 48 KPa.

The bottom to shell joint shall be tested using penetrating oil after completion of inner fillet weld and vacuum test equipment on the completed weld. Also, initial weld pass of inside shell shall be visually inspected for removal of slags and non-metals. In addition, the inner bottom to shell weld shall be 100% checked by Magnetic particle examination (MPI) in accordance with Section V of ASME Code.

The weld seams of single deck plates shall be checked for liquid tightness by vacuum box method or applying penetrating oil. Also, before the top plates of the pontoons are installed all fillet welds shall be tested for tightness, using penetrating oil, having been already thoroughly cleaned of slag and dirt. Double deck roof the bulk heads and lower centre deck also shall be tested as above.

For Aluminium geodesic dome roofs, 100% liquid penetration testing shall be performed on structural welds and components joined by welding.

Nozzle reinforcing plates shall be tested with 1 barg air pressure and soap-suds solution after welding to the shell and prior to hydrostatic test. No air leakage shall be permitted.

All welded joints in the base and shell as well as those in the floating roof necessary to ensure floatation and leak tightness shall be tested for leaks.



All NDE for acceptance purposes shall be performed after PWHT.

All lifting attachment welds shall be subjected to 100% crack detection.

### 12.3. Hydro Test

A hydrostatic test shall be conducted on field-fabricated tanks / shop-fabricated tanks after they have been placed on their foundations. Fixed roof tanks shall be tested for the design overpressure and vacuum as appropriate.

The Vendor shall be responsible for the following during testing:

	<b>MRPL Marketing Terminal Project at Devangonhi, Bangalore</b>			Page 236 of 269	
	<b>Marketing Infrastructure Projects, MRPL</b>				
	Part – C	<b>SPECIFICATION</b>  <b>FOR TANKS</b>	Tender No. :	3200000495	
	Section – C-3		Doc No.:	20005-GEN-M-SPE-4005	
Subsection – C-3.10	Rev :		1		

- Testing, including filling and emptying. If the water used for testing remains in the tank for more than 30 days, an oxygen scavenger and a corrosion inhibitor at 0.05 ml/l (50ppm) shall be added. In such a case means shall be provided for mixing.
- Installing the covers of deck manholes in floating roofs before filling.
- Furnishing, laying and removing all lines required for testing from the water disposal point.
- Cleaning out any standing water, silt or other dirt left in a tank after hydrostatic testing so that the tank interior is "broom" clean and ready for operation.

Storage Tanks shall be pressure tested hydrostatically in accordance with the requirements of API Std 650 and the data sheets. The hydrostatic test shall be carried out in the presence of the PMC / Owner / Contractor's representative.

The filling height in case of fixed roof or open roof tanks shall be up to the curb angle.

A hydraulic test procedure, specifying water filling rate and holding time, shall be submitted for PMC/ Contractor's approval.

Filling shall be in 4 stages, 25%, 50%, 75% and 100%. After each stage a load stabilization period shall be observed for 12 hours between each stage.

Hydrostatic test water shall be fresh water and for austenitic stainless-steel tanks, the chloride content shall be less than 50 ppm. The water for hydrostatic test shall be at a temperature of between 5 deg. C and 40 deg. C

Tanks with non-metallic linings or protective coatings shall be hydrostatically tested prior to the installation of such coating.

During hydrostatic test, after the water level in the tank has reached the design liquid level, fixed roof joints shall be tested for leaks by applying an internal air pressure equal to:



- the weight of roof plates for atmospheric tanks;
- the design pressure for tanks governed by clause F.1.2 of API Std 650 and,
- 1.25 times the design pressure for tanks governed by API 620 or clause F.1.3 of API Std 650.

The Vendor shall furnish all necessary test bolts, gaskets, blind flanges and facilities including temporary piping required for the pressure test. Gaskets and bolting used for hydro test shall be of same type as required for service and these gaskets shall be replaced after hydro testing.

No repairs and welding shall be carried out after pressure testing without the approval of the PMC / Owner / Contractor.

For floating roof tanks integrity test and floatation test of floating roof shall be carried in presence of PMC / Owner / Contractor.

After completion of the hydrostatic test, tanks shall be drained and dried throughout as soon as possible. Draining of the tank shall be at a rate that avoids vacuum induced collapse; all roof vents and manholes shall be open.

	<b>MRPL Marketing Terminal Project at Devangonhi, Bangalore</b>		Page 237 of 269		
	<b>Marketing Infrastructure Projects, MRPL</b>		Tender No. :	3200000495	
	Part – C	<b>SPECIFICATION</b>	Doc No.:	20005-GEN-M-SPE-4005	
Section – C-3	Rev :		1		
Subsection – C-3.10	<b>FOR TANKS</b>				

#### 12.4. Tank Settlement Measurements

Tank settlement during filling and for the duration of the hydrostatic test shall be monitored and recorded.

Hydrotest settlement readings shall be taken for every 2.4 m fill increment and just before draining is begun at following number of equal spaces, N, around the tank:  $N = D/3$  (where D= diameter in meters). Round N to the nearest even integer, but not less than four.

Vendor shall install elevation measuring stations equally spaced around the periphery of the tank on the annular plates. These stations shall consist of 100mm x 110mm plates welded on edge to the shell and numbered with weld metal on the side of each plate.

A set of at least three measurements shall be made at each location commencing inward from the inside surface of the tank shell and equally spaced on a radial line. A 100 % visual examination shall be made of the tank bottom to detect any localized depressions. The location of depressions shall be indicated on the tank bottom plate layout drawing.

The PMC / Owner / Contractor's representative shall witness the tank levels taken by the Vendor before, during and after the testing of the tank. The Vendor shall record these levels. The tanks shall be left full of water for not less than 24 hours or for such a period as required by PMC / Owner/ Contractor.

Testing of the tank shall be stopped if, in the opinion of the Inspector, settlement exceeds expected levels.

Any differential settlement shall not be greater than 1.3 mm per meter of circumference or a uniform settlement of maximum 50 mm. If settlement around the shell exceeds 1 in 180 for fixed roof tanks or 1 in 360 for floating roof tanks of the filling height during water filling, filling shall be stopped until clearance to continue has been received from the PMC / Owner / Contractor. Hydrotest water shall be held for one day unless settlement is occurring.



#### 12.5. Underground (Horizontal) tank pneumatic / Hydro tests

Each tank, before painting, shall be tested by the manufacturer and proved tight against leakage using either the following method

##### 1. Pneumatic Test (Horizontal tank)

Prior to pressurization, the external surface of the tank should be inspected for defects. A compressed-air source is applied (according to the manufacturer's recommended procedures) to raise the internal tank pressure to a level recommended for this test by the tank manufacturer. A pressure gauge with a maximum range of 10-15 pounds per square inch gauge with graduations of no more than ¼ pound increments should be used to confirm proper pressurization.

When the internal pressure is achieved, the compressed air source should be disconnected from the tank, and the entire tank shell, as well as all seams, bungs, and manholes should be uniformly coated

	<b>MRPL Marketing Terminal Project at Devangonhi, Bangalore</b> <b>Marketing Infrastructure Projects, MRPL</b>		Page 238 of 269		
	Part – C	<b>SPECIFICATION</b>  <b>FOR TANKS</b>	Tender No. :	3200000495	
	Section – C-3		Doc No.:	20005-GEN-M-SPE-4005	
Subsection – C-3.10	Rev :		1		

and recoated as necessary with a soap solution. Leaks are detected by the presence of bubbles identified by a visual inspection. The importance of this visual inspection cannot be over emphasized.

If bubbles are observed around fittings, the fittings should be checked for tightness and repaired as necessary. If leaks are detected in seams or the shell, the supplier and/or the manufacturer should be notified and the leak eliminated prior to installation. When the inspection is completed, the air pressure should be released.

## 2. Hydro Test (Horizontal tank)

Completely filling the tank with water and applying an additional gauge pressure of 7 psi (48.3 kPa) pressure at least for one hour while the tank is placed in the position in which it shall be installed and observing for water leakage from the tank and fittings by hammering around all welded joints. Tank should not leak at any joint. Acceptance/Rejection will be as per PMC / MRPL approved drawing for dimensions. Check list and stage wise inspection report /release note to be given by TPIA.

When leaks are noted during the test, the tank shall be made tight by welding and retested. Defects in welds shall be repaired by chipping or melting out from one or both sides of the joint, as required, and rewelding.

All the materials including the blind flanges, gaskets, bolting nipples, plugs, water and all other items required during hydrostatic testing shall be arranged by the fabricator at their own cost.

## 13. SURFACE PREPARATION & PAINTING REQUIREMENTS

Package painting shall be in accordance with the Engineering Design Basis for Surface Preparation and Protective Coating.



Final paint shade and thickness of coating for exterior and interior shall be as specified in Vendor drawings. All components to be painted shall have their sharp edges ground smooth. Coating application shall not commence unless all welding, grinding, inspection and repairs (if any is required) and including hydrostatic testing is fully complete.

When the tank is pre-fabricated in the shop and shipped in knocked-down condition to site for subsequent assembly and welding, plate sections (both sides) shall be shop coated by Vendor with the approved priming paints as specified in the painting specification. Vendor shall then at site shall remove the wash primer from all areas requiring painting by blast cleaning to the required surface finish before applying the primer & paint as per above Technical specification for painting.

All structural steels (including ladders, platforms, stairs, framings etc.) shall be galvanized.

Nozzles shall be painted to the flange edges, inside bolt holes and up to but excluding the gasket surface.

Internal coatings shall be carried out as specified on the tank mechanical data sheets.

	<b>MRPL Marketing Terminal Project at Devangonhi, Bangalore</b>		Page 239 of 269		
	<b>Marketing Infrastructure Projects, MRPL</b>		Tender No. :	3200000495	
	Part – C	<b>SPECIFICATION</b>	Doc No.:	20005-GEN-M-SPE-4005	
Section – C-3	Rev :		1		
Subsection – C-3.10	<b>FOR TANKS</b>				

#### 14. PREPARATION FOR SHIPMENT

Vendor shall comply with the project specifications attached with the Requisition for packing and forwarding shop fabricated tanks and pre-fabricated tank components.

All tanks shall be complete with necessary temporary support steelwork to enable safe transportation, lifting and installation.

All plates and structural (including ladders, platforms, stairs, framings etc.) shall be cut, rolled and match marked. All rolled plates shall be placed on fabricated saddle to maintain the curvature.

All flanged connections of tanks not fitted with blinds shall be sealed with 6mm thick metal discs, rubber gaskets and four bolts before being wrapped around their circumference with Denso tape or equivalent.

All exposed machined and threaded surfaces shall be thoroughly coated with a suitable rust preventative compound and suitably protected for shipment. All female threaded connections shall be fitted with solid pipe plugs of the same material as the connection. All vent holes in reinforcing pads shall be plugged with heavy grease, unless otherwise specified.

All flange faces & other machined surfaces shall be covered with grease to avoid rusting.

The Vendor shall be responsible for loading and anchoring tanks to prevent any damage during shipment.

All loose parts shall be adequately crated and given clear markings relating the parts to the tank identification number. The Tags and wire used for markings shall be stainless steel.

The Vendor shall ensure that all items are protected with suitable preservation and packing.

#### 15. DOCUMENTATION



Vendor shall provide all documents with the number of copies and soft-files, as listed in the VDRL attached with the requisition.

Drawings and Calculations: Fabrication drawings submitted to Contractor / Owner / PMC for review shall be complete with all dimensions, thicknesses and details of construction, including location of weld seams and nozzles and orientations. All material thicknesses shall be shown. All welds and weld preparations shall be detailed or fully described by notes or weld symbols and annotated to the relevant weld procedure specification.

The Vendor shall submit his calculations for seismic design to the PMC / Purchaser for approval.

The General Assembly drawings shall contain all pertinent information relating to the standards, codes and specifications used in design, fabrication, inspection and testing of the tanks, material of construction, nozzle list, design data and foundation load data.

The foundation load data shall include weights (empty, operating & hydrotest), shear forces & moments due to wind and seismic, uplift due to wind & internal pressure and the counter balancing weight if applicable.

	<b>MRPL Marketing Terminal Project at Devangonhi, Bangalore</b>		Page 240 of 269		
	<b>Marketing Infrastructure Projects, MRPL</b>		Tender No. :	3200000495	
	Part – C	<b>SPECIFICATION</b>  <b>FOR TANKS</b>	Doc No.:	20005-GEN-M-SPE-4005	
Section – C-3	Rev :		1		
Subsection – C-3.10					

Relevant design information furnished by the PMC / Owner / Contractor shall be checked by the Vendor and referenced together with explanatory notes on the appropriate drawing.

Vendor shall include a welding map to be prepared for each item, including an outline drawing that identifies all welds (incl. those to pressure parts) and cross references to related weld procedure number, material group and thickness.

The Vendor shall prepare detailed calculations establishing the compliance of the tank design with the requirements of the codes and specifications listed in this specification. The calculations shall be submitted to the PMC / Contractor for review.

Calculations shall show the formulae used together with the material properties and design conditions being analysed. Where Code calculation methods do not exist and alternative procedures are used, procedure of such calculations shall be fully explained and validated by the Vendor.

Computer print-outs for design calculation are acceptable provided the design report clearly shows the input data and the calculation formulae in addition to the output data.

For the Floating roof tanks the Vendor shall submit calculations in sufficient detail to show that all requirements of this specification and API Standard 650 for the design of the floating roof have been met. Calculations shall be included for the punctured & flood condition for any two compartments, twice the dead weight condition and stress calculations for live loads on roof as per the requirement of API STD 650 Appendix H for internal floating roof tanks and rain water filled condition and punctured & flood condition for two adjacent pontoon/deck compartments and stress calculations for live loads on roof as per the requirement of API STD 650 Appendix C for external floating roof tanks.

Vendor shall submit a design calculation for the floating roof showing the submergence of roof during normal floatation and floating under punctured condition. The design report shall also include stress analysis of the roof & leg supports and sizing of bleeder vent, roof drains.



Vendor shall develop and submit all design calculations, drawings, list of materials & bill of materials, storage & erection procedure, list of special tools & consumables required for erection and ITP (Inspection and Test Plan) for the floating roof to PMC / Purchaser for review and prior approval.

Floatation test shall be the responsibility of Vendor. Procedure for the floatation test shall be submitted to Purchaser for prior approval.

Review of drawings, calculations and other documents by the PMC / Owner / Contractor, does not relieve the Vendor of his responsibility for the correctness of the design to suit the stated conditions.

The Vendor shall supply Manufacturing Record Books containing all material certificates, fully catalogued and indexed NDT test records, mechanical test certificates, welding qualification certificates, heat treatment certificates, hydrostatic test certificates, fabrication drawings, weld procedures, nameplate rubbing or photograph and other data specified in the VDRL.



	<b>MRPL Marketing Terminal Project at Devangonhi, Bangalore</b>		Page 241 of 269		
	<b>Marketing Infrastructure Projects, MRPL</b>		Tender No. :	3200000495	
	Part – C	<b>SPECIFICATION</b>  <b>FOR TANKS</b>	Doc No.:	20005-GEN-M-SPE-4005	
Section – C-3	Rev :		1		
Subsection – C-3.10					

Approval of documents by the PMC / Owner / Contractor does not relieve the Vendor from his responsibility/obligation to supply the equipment as per requirements specified in the requisition, its attachments, codes and standards referred therein.

#### 16. WARRANTY

Vendor shall have final and total responsibility for the design and performance of all equipment furnished by him. Vendor shall warrant that the equipment furnished by him and the performance of the said equipment is in accordance with this specification and general codes.

Vendor shall warrant and guarantee that all the materials and equipment incorporated in the entire equipment under his Scope shall be new, and all work shall be of good quality.

Vendor shall also be responsible for all system and detailed designing, the aspects of which may not have been covered in this specification as regards the workmanship, performance etc., of the equipment supplied by him.

Vendor shall, upon notice from PMC, make good at his own expense all defects found during the warranty period expeditiously.

Vendor shall, if required, supply the services of an experienced engineer to supervise the correction of any defects found during the warranty period.

Vendor shall also warrant and guarantee all work, materials and equipment furnished by any Sub-Vendor and which is incorporated in the Package.

#### 17. QUALITY ASSURANCE

Vendor shall operate a Quality Management System which meets the requirements of ISO 9001:2015 or equivalent standards acceptable to the COMPANY. Evidence of certification by a recognized independent accredited certification body to ISO 9001:2015 or equivalent shall be submitted during bid stage. Certification shall be current, appropriate for the WORK and applicable to the designated organization and location. Successful vendor shall also submit their as well as their major sub-vendor's certificates after order.

	<b>MRPL Marketing Terminal Project at Devangonhi, Bangalore</b>				
	<b>Marketing Infrastructure Projects, MRPL</b>				
	<b>Part – C</b>	<b>PIPELINE DESIGN BASIS</b>	Tender No :		3200000495
	<b>Section – C-2</b>		Document No:		20005-GEN-PL-EDB-7010
<b>Subsection – C-2.5</b>	Rev :		1		

<b>C-2</b>	<b>ENGINEERING DESIGN BASIS</b>
<b>C-2.5</b>	<b>PIPELINES</b>

## MRPL Marketing Terminal Project at Devangonhi, Bangalore



**PROJECT :** Marketing Infrastructure Projects, MRPL

**OWNER :** MANGALORE REFINERY AND PETROCHEMICALS LTD

**PMC :** NAUVATA ENGINEERING PVT. LTD.



**JOB NO. :** JBG20005

Rev. No	Date	Purpose	Prepared by	Checked by	Approved by
1	06-05-2021	Re-ISSUED FOR BID	PB	SVV	SVV
0	12-03-2021	ISSUED FOR BID	PB	SVV	SVV

	<b>MRPL Marketing Terminal Project at Devangonhi, Bangalore</b>			Page 243 of 269	
	<b>Marketing Infrastructure Projects, MRPL</b>				
	<b>Part – C</b>	<b>PIPELINE DESIGN BASIS</b>	Tender No :	3200000495	
	<b>Section – C-2</b>		Document No:	20005-GEN-PL-EDB-7010	
<b>Subsection – C-2.5</b>	Rev :		1		

## TABLE OF CONTENTS

<b>1. INTRODUCTION.....</b>	<b>3</b>
<b>2. SCOPE OF DOCUMENT .....</b>	<b>3</b>
<b>3. DESIGN CODES AND STANDARDS .....</b>	<b>3</b>
<b>4. DESCRIPTION OF FACILITIES .....</b>	<b>4</b>
<b>5. DESIGN DATA .....</b>	<b>4</b>
<b>6. PIPELINE AND ASSOCIATED FACILITIES DESIGN.....</b>	<b>4</b>
<b>7. OTHER TECHNICAL REQUIREMENTS .....</b>	<b>8</b>

	<b>MRPL Marketing Terminal Project at Devangonithi, Bangalore</b> Page 244 of 269 <b>Marketing Infrastructure Projects, MRPL</b>				
	<b>Part – C</b>	<b>PIPELINE DESIGN BASIS</b>	Tender No :		3200000495
	<b>Section – C-2</b>		Document No:		20005-GEN-PL-EDB-7010
	<b>Subsection – C-2.5</b>		Rev :		1

## 1. INTRODUCTION

Mangalore Refinery & Petrochemicals Limited (MRPL), is setting up new Marketing Terminal as part of the MRPL Marketing Projects. It proposes to have a pipeline-fed Petroleum Terminal at Devangonithi, Bengaluru to cater to the MS and HSD requirement. M/s MRPL has envisaged to effect supplies for sales through its own Retail and Consumer Channels and also effect supplies to other players like M/s. Shell India /Other Retail players. The product would be pumped through the pipeline owned by M/s. Petronet MHBL. M/s. Nauvata Engineering Pvt. Ltd. has been appointed by MRPL to provide services for Project Management Consultancy (PMC). The project is being executed through Single Lump Sum Turnkey (LSTK) package including Engineering, Procurement, Construction and Commissioning (EPCC).

The conceptualized terminal comprises of MS, HSD and ATF Storage tanks and gantry facility for truck tanker loading along with associated facilities.

## 2. SCOPE OF DOCUMENT



This document establishes minimum design parameters and basis for design and detailed engineering of the Pipeline and Associated facilities covered under this project as defined briefly herein below.

## 3. DESIGN CODES AND STANDARDS

Pipelines and terminal facilities envisaged shall be designed and engineered primarily in accordance with the provisions of the latest edition of Code ASME B31.4: Pipeline Transportation Systems for Liquid Hydrocarbons and Other Liquids and OISD 141: Design and construction Requirements for Cross Country Hydrocarbon Pipelines. In addition, requirements, as applicable to gas service of following codes/standards shall be complied with:

OISD Std. 138	Inspection of Cross Country Pipelines-Onshore
ASME B 31.3	Chemical Plant & Petroleum Refinery Piping
API Std. 1102	Steel Pipeline Crossing Railways & Highways
API Std. 1104	Standard for Welding Pipelines and Related Facilities
ISO 13623	Petroleum & natural gas industries – Pipeline transportation systems

In case of conflict between the requirements of ASME B31.4/OISD 141 and other codes/Standards referred above, requirement of ASME B 31.4/OISD 141 shall govern. In case of conflict between requirements of B31.4/OISD 141 and this document, requirements of this document shall govern.

 <b>ONGC</b> एन.ओ.एन.सी.पी.एल. <b>MRPL</b>	<b>MRPL Marketing Terminal Project at Devangonthi, Bangalore</b> Page 245 of 269 <b>Marketing Infrastructure Projects, MRPL</b>			 <b>nauvata</b> ENGINEERING CONSULTANTS	
	<b>Part – C</b>	<b>PIPELINE DESIGN BASIS</b>	Tender No :		3200000495
	<b>Section – C-2</b>		Document No:		20005-GEN-PL-EDB-7010
	<b>Subsection – C-2.5</b>		Rev :		1

#### 4. DESCRIPTION OF FACILITIES

- a. Design, Supply and Laying of 3 Nos. of 14” HSD, ATF and MS product Pipelines from Manifold located inside PMHB Facility at Devangonthi to PLT manifold inside MRPL Marketing Terminal.
- b. 2 number of OFC shall be laid along with the proposed 3 Nos. of pipelines from Manifold located inside PMHB Facility at Devangonthi to PLT manifold inside MRPL Marketing Terminal.

#### 5. DESIGN DATA

Pipeline shall be designed to the conditions as follows:



<b>PIPELINE DESIGN PARAMETER FOR HSD, ATF AND MS PRODUCTS</b>	
DESCRIPTION	VALUE
Design Pressure (Kg/ Cm <sup>2</sup> g)	70
Operating Pressure (Kg/ Cm <sup>2</sup> g)	5 to 20
Maximum Design Temperature (°C)	65
Operating Temperature (°C)	15 to 50
Economic Design Life, Years	25 years
Corrosion Allowance (mm)	3mm

#### 6. PIPELINE AND ASSOCIATED FACILITIES DESIGN

##### 6.1 Pipeline

Pipeline shall be designed in accordance with requirements of ASME B 31.4 and OISD 141. The pipeline shall withstand all installation, testing and operating condition/ loads. All necessary calculations shall be carried out to verify structural integrity and stability of the pipeline for the combined effect of pressure, temperature, bending (elastic), soil/pipe interaction, external loads and other environmental parameters as applicable during all phases of work from installation to operation. Allowable stress limit shall be as per ASME B 31.4. Such calculations shall include, but are not limited to following:

- Stress analysis at crossing of highway etc.
- Pipeline expansion and its effect on station piping (above ground/below ground).
- Pipeline shall also be checked for adequacy against anticipated earthquake loading and any special measures such as increase in wall thickness/ grade/ select backfill etc. as required to ensure safety and integrity of the pipeline system shall be implemented.
- Pipeline and its associated facilities shall be designed using the applicable design code

	<b>MRPL Marketing Terminal Project at Devangonhi, Bangalore</b> Page 246 of 269 <b>Marketing Infrastructure Projects, MRPL</b>				
	<b>Part – C</b>	<b>PIPELINE DESIGN BASIS</b>	Tender No :		3200000495
	<b>Section – C-2</b>		Document No:		20005-GEN-PL-EDB-7010
	<b>Subsection – C-2.5</b>		Rev :		1

and as modified below.

The pipeline shall be designed to meet the Location Class as defined in ASME B31.4, except as modified below.



Location Class	Type of Facility	Design Factor
All	Station Piping	0.5
Class – 1	River / Stream Crossings	
	Drilled / Bored/ Inaccessible / Open cut	0.6
	Others	0.72
	HDD	0.5
	Cased/Uncased Crossings or Parallel Encroachments on ROW of Hard Surfaced Roads, Public Streets and Highways	0.6
	Railway Crossing	0.5
Class – 2	River / Stream Crossings	
	Drilled / Bored/ Inaccessible / Open cut	0.5
	Others	0.6
	HDD	0.5
	Cased/Uncased Crossings or Parallel Encroachments on ROW of Hard Surfaced Roads, Public Streets and Highways	0.5
	Railway Crossing	0.5
Class – 3	All	0.5
Class – 4	All	0.4

### 6.3 Station Piping

Station piping to be provided at PMHB Manifold and pipeline terminal (PLT) manifold (MRPL Terminal) shall be designed in accordance with OISD 141/ASME B 31.4 and utility piping to be provided at these locations shall be designed in accordance with the provisions of ASME B 31.3.

All piping shall be designed for combined effects of pressure, weight and temperature during operating conditions without over stressing the piping, valves or equipment. All piping shall be adequately supported, guided or anchored so as to prevent undue vibration, deflection or loads on connected equipment such as filters, meters etc.

### 6.4 Materials

 <b>ONGC</b> एन.ओ.एन.सी. <b>MRPL</b>	<b>MRPL Marketing Terminal Project at Devangonhi, Bangalore</b> Page 247 of 269 <b>Marketing Infrastructure Projects, MRPL</b>			 <b>nauvata</b> ENGINEERING CONSULTANTS	
	<b>Part – C</b>	<b>PIPELINE DESIGN BASIS</b>	Tender No :		3200000495
	<b>Section – C-2</b>		Document No:		20005-GEN-PL-EDB-7010
	<b>Subsection – C-2.5</b>		Rev :		1

Pipeline and its appurtenances shall be provided with carbon steel materials suitable for the intended service, as detailed in subsequent paragraphs.

### Line pipe for main line

Proposed 3 Nos. of HSD, ATF and MS product line pipes shall conform to API 5L and specification 20005-GEN-PL-SPE-7001. Type of line pipe shall be Ø355.6 mm (14”) x 14.3mm WT, API 5L Gr B, PSL-2, CS SEAMLESS. 

### Other Materials

All other pipeline associated materials in general including Insulation joints, Valves, Flanges and Fittings, if any, shall be carbon steel.

### External/ Internal corrosion coating

Pipeline to be installed below ground shall be protected against external corrosion by a combination of high integrity externally applied coatings and permanent impressed cathodic protection system. Externally applied coating shall be three layer side extruded polyethylene coating, refer specification 20005-GEN-PL-SPE-7003.

In addition, pipeline shall be provided with minimum 80 micron thick liquid epoxy internal coating conforming to ISO 15741/API RP 5L2. Extremities of pipe shall be free from coating over a length of 20± 5 mm.

All above ground piping and structures shall be painted to prevent atmospheric corrosion. Painting of above ground piping and structures shall be as per specifications. Painting shall be as per MRPL’s Painting Specification.

### Insulating joints



Insulating joints shall be provided to electrically isolate the buried pipeline from above ground pipeline. Insulating joints shall be monolithic type. Insulating joints shall be installed in above ground portion of the pipeline, immediately after the buried/aboveground transition.

Wherever pressure/ temperature transmitters are used on cathodically protective pipeline the same shall be electrically isolated by providing insulating joints/ flanges.

### Pipeline Burial

The pipeline shall be buried normally at a depth of 1.0 meter below natural ground level except road/waterways crossing (if any) where minimum cover shall be as given below or as per the requirements of statutory/local authorities, whichever is more stringent. Increased cover shall be provided at critical locations and crossings.

Sl. No.	Location	Minimum Cover
---------	----------	---------------

	<b>MRPL Marketing Terminal Project at Devangonthi, Bangalore</b> Page 248 of 269 <b>Marketing Infrastructure Projects, MRPL</b>				
	<b>Part – C</b>	<b>PIPELINE DESIGN BASIS</b>	Tender No :		3200000495
	<b>Section – C-2</b>		Document No:		20005-GEN-PL-EDB-7010
	<b>Subsection – C-2.5</b>		Rev :		1

1	Industrial, commercial and residential area	1.0
2	Rocky terrain	1.0
3	Minor water crossing/ canal/ drain/ nala/ waterways	1.5
4	HDD crossing of canals (below bed)	2.5
5	River crossings for which scour depth is defined (below scour)	1.5
6	Other River crossings (Bank width > 50m) (Below Bed)	2.5 (For normal soil) 1.5 (For rocky strata)
7	Other River crossings (Bank width < 50m) (Below Bed)	1.5
8	Cased/uncased road crossing	1.2
9	Cased railway crossing	1.7
10	Drainage, ditches at roads/railway crossings	1.2
11	Marshy land/Creek area	1.5

Additional soil cover other than specified above shall be provided at locations indicated by statutory/ local authorities or in areas likely to have an increased risk of impact damage or third party interference as per agreements between COMPANY and authorities. In case, any private dwelling, industrial building or place of public assembly falls within 15 m of pipeline, additional cover of minimum 300 mm shall be provided over and above the cover indicated in the above table.

### **Pipeline in common ROW**

The location of new underground pipeline, when running parallel to an existing underground pipeline in same ROU/ROW shall be laid at minimum clear distance of 5.0m from the existing underground pipeline.



This distance may be reduced to 3.0 m after assessment of construction methodology which do not result in unsafe conditions during construction.

### **Backfilling**

In normal areas, the pipeline trench shall be backfilled with excavated soil. Select rock fill/ slope breakers shall be provided in the trench in steep areas (slope generally 10% and more) to prevent erosion. In case of water bodies prone to scour and erosion, the safety cover shall be provided below the predicted scour level. In addition to the cover, anti-buoyancy measures (concrete coating) shall be provided at water body crossings.

Contractor shall keep top 150 mm of excavated top soft soil (free of gravels) aside, which shall be back filled in the end as top layer.



	<b>MRPL Marketing Terminal Project at Devangonthi, Bangalore</b> Page 249 of 269 <b>Marketing Infrastructure Projects, MRPL</b>				
	<b>Part – C</b>	<b>PIPELINE DESIGN BASIS</b>	Tender No :		3200000495
	<b>Section – C-2</b>		Document No:		20005-GEN-PL-EDB-7010
	<b>Subsection – C-2.5</b>		Rev :		1

Select backfill shall be provided at approaches to terminal up to transition point (below ground/above ground) inside terminal.

Select back fill shall also be provided as applicable for areas prone to seismic activity. Recommendation of Seismic Analysis Report should be considered for such special backfill.

Disposal of debris and surplus material to designated disposal areas or designated place(s), as the case may be and as directed by Engineer-in-charge shall be carried out.

## 7. OTHER TECHNICAL REQUIREMENTS

### 7.1 Piping

#### General

All piping and equipment shall be designed as per ASME B 31.4. All piping materials shall be as per Piping Material Specification (PMS). Utility piping to be provided shall be designed in accordance with the provisions of ASME B 31.3.

Design shall provide consideration for all loadings like weight, temperature etc., significantly affecting the pipe material stresses in addition to fluid pressure.



#### Piping flexibility/stress analysis

All piping shall be designed for thermal expansion under start up, operating and shut down conditions without over stressing the piping, valves or equipment. Provisions for expansion shall normally be made with bends and offsets.

All piping shall be adequately supported, guided or anchored so as to prevent undue vibration, deflection or loads on connected equipment. Valves requiring periodical maintenance shall be supported in such a way that the valves and equipment can be removed with minimum temporary pipe supports.

#### Piping layout

- ✓ Piping will be located above-ground wherever possible within the terminals.
- ✓ Piping shall be designed considering skin temperature of piping material under empty conditions as 65°C or design temperature of pipeline whichever is higher.
- ✓ Piping stress analysis shall be carried out to determine allowable pipe movement and support requirements wherever felt necessary.
- ✓ Buried piping inside the terminal area will have a minimum depth of cover of 1.2 m.
- ✓ Where buried pipes come out of the ground, the underground coating on the pipe will continue for a distance of 500 mm above ground.
- ✓ Platforms, crossovers shall be provided for ease of operation and maintenance, if any.

	<b>MRPL Marketing Terminal Project at Devangonhi, Bangalore</b> Page 250 of 269 <b>Marketing Infrastructure Projects, MRPL</b>				
	<b>Part – C</b>	<b>PIPELINE DESIGN BASIS</b>	Tender No :		3200000495
	<b>Section – C-2</b>		Document No:		20005-GEN-PL-EDB-7010
	<b>Subsection – C-2.5</b>		Rev :		1

- ✓ Platform for filters shall be provided for maintenance/ operational access.
- ✓ Painting above ground piping and structures shall be as per MRPL's specification.

## 7.2 Welding

Welding shall be carried out in accordance with API 1104, specification for welding and welding charts. Butt welds shall be 100 % radio graphed / automatic UT for automatic welding, as applicable for all pipelines.

## 7.3 Hydrostatic Testing

After installation, the entire pipeline system shall be hydrotested with inhibited water. The water shall be tested, as applicable prior to using for hydrotesting. The minimum hydrostatic pressure in any section shall be as per ASME B 31.4 for gaseous hydrocarbon pipelines. The maximum hydrostatic test pressure at any location of the pipeline shall not exceed the pressure required to produce a hoop stress equal to 95% of SMYS of the pipe material based on minimum wall thickness in the test section. The test duration shall be minimum 24 hours. Hydrostatic testing of terminals shall be carried out separately. Terminals as well as other intermediate facilities shall be tested at 1.4 times the design pressure. The test duration shall be 6 hours. Mainline valves shall be installed after successful completion of hydrotesting.

## 7.4 Crossings



### Water Crossings (if any)

All water crossing shall be installed by open cut. The requirement of HDD at any water crossing shall be finalized during detailed engineering. Wherever there is an evidence of bank erosion, the banks shall be protected by using gravel and boulders filled embankment mattresses of galvanized iron wire to be laid over the backfilled, compacted and graded banks.

### Road Crossing

Road crossings shall comply with the requirements of API 1102 and the requirements of the concerned road authorities. Unless otherwise required by concerned Authorities, casing pipe shall not be used. However at national highway road crossings pipeline shall be provided with casing pipe, which shall extend min. 600 mm beyond Road ROW on either side. The casing pipe shall be installed by trenchless method like ramming/ boring/ jacking/ HDD /Micro Tunnelling. Provision of casing at locations other than national highways shall be decided based on type of road crossing and as per requirements of local authorities if necessary. The casing pipe diameter/wall thickness shall be calculated as per codes and standards. The crossing angle shall be as close to 90° as possible. Casing insulators and end seals shall be provided to ensure electrical isolation of carrier pipe and casing pipe.



### Existing Pipeline Crossing

	<b>MRPL Marketing Terminal Project at Devangonthi, Bangalore</b> Page 251 of 269 <b>Marketing Infrastructure Projects, MRPL</b>				
	<b>Part – C</b>	<b>PIPELINE DESIGN BASIS</b>	Tender No :		3200000495
	<b>Section – C-2</b>		Document No:		20005-GEN-PL-EDB-7010
	<b>Subsection – C-2.5</b>		Rev :		1

The specific requirements of Owner/operator of existing pipeline shall generally be followed. The minimum clearance between the lines shall be 300 mm unless specified otherwise.

### 7.5 Pipeline Bends

In order to accommodate changes in vertical and horizontal alignment in a section of pipeline, elastic bends/cold field bends/hot formed long radius bends shall be used. Miter bends shall not be used for change in direction. Necessary design/calculation for arriving Minimum Elastic Bend Radius shall be worked out by Contractor and shall be approved by PMC.

	<b>MRPL Marketing Terminal Project at Devangonhi, Bangalore</b>				
	<b>Marketing Infrastructure Projects, MRPL</b>				
	Part – C	<b>Specifications- Double Block &amp; Bleed VALVE</b>	Tender No. :		3200000495
	Section – C-3		Doc No.:		20005-GEN-I-SPE-6017
Subsection – C-3.60	Rev :		0		

<b>C-3</b>	<b>SPECIFICATIONS</b>
<b>C-3.60</b>	<b>SPECIFICATONS DOUBLE BLOCK AND BLEED VALVE</b>

## MRPL Marketing Terminal Project at Devangonhi, Bangalore



**PROJECT :** Marketing Infrastructure Projects, MRPL

**OWNER :** MANGALORE REFINERY AND PETROCHEMICALS LTD

**PMC :** Nauvata Engineering Pvt. Ltd.

**JOB NO. :** JBG20005

0	09-03-2021	ISSUED FOR BID	RB	SKH	SV
<b>Rev. No</b>	<b>Date</b>	<b>Purpose</b>	<b>Prepared by</b>	<b>Checked by</b>	<b>Approved by</b>

	<b>MRPL Marketing Terminal Project at Devangonhi, Bangalore</b>			Page 253 of 269	
	<b>Marketing Infrastructure Projects, MRPL</b>				
	Part – C	<b>Specifications- Double Block &amp; Bleed VALVE</b>	Tender No. :		3200000495
	Section – C-3		Doc No.:		20005-GEN-I-SPE-6017
Subsection – C-3.60	Rev :		0		

## TABLE OF CONTENTS

### Contents

1.	<b>GENERAL</b> .....	3
2.	<b>ABBREVIATIONS</b> .....	3
3.	<b>CODES AND STANDARDS</b> .....	4
4.	<b>DOUBLE BLOCK AND BLEED VALVE</b> .....	5
6.	<b>MARKING</b> .....	16
7.	<b>PAINTING/PREPARATION OF SHIPMENT</b> .....	16
8.	<b>SPARES &amp; SPECIAL TOOLS</b> .....	17
9.	<b>COMMISSIONING ASSISTANCE &amp; WARRANTIES</b> .....	17



## 1. GENERAL

This Specifications covers the general requirements for Double Block and Bleed Valve.

Note: The contradictions shall be brought to the notice of Owner / Consultant immediately for approval. All design shall be done based on the Best Available Technology

## 2. ABBREVIATIONS

TFMS	Tank Farm Management System
LRCS	Loading Rack Computer System
EWS	Engineering Work Station
OIC	Operator Interfacing Console
TTRS	Tank Truck Reporting System
TTES	Tank Truck Entry System
HWP	Hardwired Panel
ROSOV	Remote Operated Shut Off Valve
DBBV	DOUBLE BLOCK AND BLEED VALVE
MOV	Motor Operated Valve
CIU	Communication Interfacing Unit
ISA	Instrument Society of America
IEC	International Electro-technical Commission
IEEE	Institute of Electrical & Electronics Engineers
HAZOP	Hazard and Operability Study
UL	Underwriters Laboratory Inc
MCR	Main Control Room
EN	European Nation
EUC	Equipment Under Control
ESD	Emergency Shutdown System
SIS	Safety Instrumented System
E/E/P/S	Electrical and Electronics Programmable Systems
ANSI	American National Standards Institute
HMI	Human Machine Interface
SIL	Safety Integrity Limit
DIN	Deutsches Institut Tur Normung eV
ATEX	<i>ATmosphères EXplosibles</i>
CENELEC	European Committee for Electro technical Standardization
TUV	Technische Uberwarchungs Verein
NEMA	National Electrical Manufacturers Association
CPU	Central Processing Unit
I/O	Input/ Output
UPS	Un-interrupted Power Supply
FAT	Factory Acceptance Test
SAT	Site Acceptance Test

	<b>MRPL Marketing Terminal Project at Devangonhi, Bangalore</b>				
	<b>Marketing Infrastructure Projects, MRPL</b>				
	Part – C	<b>Specifications- Double Block &amp; Bleed VALVE</b>	Tender No. :		3200000495
	Section – C-3		Doc No.:		20005-GEN-I-SPE-6017
Subsection – C-3.60	Rev :		0		



### 3. CODES AND STANDARDS

The components of Instrumentation and Control system shall conform in design, materials and performance with the appropriate sections of the latest editions and revisions of the standards. The equipment shall also conform to the latest Indian Electricity Rules as regards safety, earthing and other essential provisions specified there in for the installation and operation of electrical plants.

The equipment in the hazardous area shall have CMRI/ATEX & CCOE/PESO approvals.

#### API American Petroleum Institute

API 6D	Specification for pipeline Valve
API 6FA	Specification for fire test of Valves
API 598	Valve Inspection and testing
ASME B1.20.1	Pipe Threads General Purpose ( Inch)
ASME B16.5	Steel Pipe flanges and Flanged fittings
ASME B16.10	Face to face and End to end Dimension of Valves
ASME B16.34	Valves-Flanged , Threaded and Welding End
ASME B31.3	Chemical Plant and Petroleum refinery piping
ASME B31.4	2004 Liquid transportation for hydrocarbons and other Liquids
ANSI B46.1	Surface texture (Surface roughness, waviness and Lay)
BSEN 12266	Industrial valves, Testing of Valves , Test procedure and Acceptation criteria
BS-EN-102222	Specification assistance for Steel forgings for pressure purpose
BS-EN10213	Specification for Steel coating for pressure Purpose
BS-1560	Steel pipe flanges and flanged fittings
BS-EN-1092	Flanges and their joints Circular flanges for pipes, valves , fitting and accessories, PN designated
BS-EN1515-1	Flanges and Their Joints
BS 5146	Inspection and test of steel valves for Petroleum, Petrochemical and Allied Industries
MSS -SP-6	Standard finishes for contact faces for pipe flanges and connecting end Flanges of Valves and Fitting
MSS-SP-25	Standard Making system for Valves, fitting Flanges and Unions.
MSS-SP-44	Steel pipeline Flanges
MSS-SP-45	By-Pass and drain connection Standards
MSS-SP-61	Pressure Testing of Steel Valves
MSS-SP-65	Quality Standards for Steel costing

	<b>MRPL Marketing Terminal Project at Devangonhi, Bangalore</b>				
	<b>Marketing Infrastructure Projects, MRPL</b>				
	Part – C	<b>Specifications- Double Block &amp; Bleed VALVE</b>	Tender No. :		3200000495
	Section – C-3		Doc No.:		20005-GEN-I-SPE-6017
Subsection – C-3.60	Rev :		0		

#### 4. DOUBLE BLOCK AND BLEED VALVE

##### 4.1 SCOPE

This specification establishes the technical requirements for Double block & bleed and double Isolation valves with single operator to be used for positive isolation purpose.

The valve shall be conforming to API-6D specifications & shall bear API-6D monogram.

This specification establishes the technical requirements for Double block & bleed and double Isolation valves with single operator to be used for positive isolation purpose while handling refined petroleum liquid hydrocarbon products like ( MS,HSD,ATF,PCK etc).

This specification covers the minimum requirements for the design, manufacture, Assembly, Inspection, testing, certification & delivery of Manual / electrically operated Double block & bleed and double Isolation valves complete with all accessories.

##### 4.2 DEVIATIONS TO SPECIFICATIONS

The Bidder shall provide an itemized list of any deviations to this specification. These shall be listed on the Compliance sheet with seal & duly signed by authorized signatory & shall be submitted along with offer by the Bidder.

Where a conflict between standards occurs then the Bidder shall seek a clarification ruling from the Owner. Where a deviation from the standard is required, then the Bidder shall make a formal request with full supporting information.

Only those deviations that are agreed between the Owner and the Bidder will be incorporated into the requisition at the time of order.

##### 4.3 CONFLICTING REQUIREMENTS

In case of conflict between the requirements of this specification, API 6-D and the Codes, Standards and Specifications referred above, the requirements of this specification shall govern. Order of precedence shall be as follows:

First priority - This Specification

Second priority - API 6-D/6FA

Third priority - Other Referred Codes & Standards

Fourth priority - Manufacturer's Standard



**Note:** Should any conflict arise either before or after order placement the Bidder shall immediately inform the Owner for technical resolution of the conflict.

##### 4.4 GENERAL FEATURES / SPECIFICATIONS

The valve shall have one operator only. Gear operation (with or without reduction gear) shall be provided as per manufacturer's specifications / relevant standards.

Gear operator shall be provided with position indicators for open/ close positions, with limit stops as per manufacturer's design in line with API- 6D. The operators shall be totally enclosed of helical



	<b>MRPL Marketing Terminal Project at Devangonithi, Bangalore</b>			Page 257 of 269	
	<b>Marketing Infrastructure Projects, MRPL</b>				
	Part – C	<b>Specifications- Double Block &amp; Bleed VALVE</b>	Tender No. :		3200000495
	Section – C-3		Doc No.:		20005-GEN-I-SPE-6017
Subsection – C-3.60	Rev :		0		

worm/bevel or combination of helical worm, bevel and spur gear in grease case with grease nipples/ plugs or as per specifications of manufacturers with weather protection

Gear operator shall be so designed to operate the valve at **break away torque** as defined in API-6D. The maximum force required at the hand- wheel or wrench to apply the breakaway torque or thrust shall not exceed 360 N (80 lbf). However failing to meet the above requirements vendor shall offer gear-operated valve.

Valves with wrench or lever operators shall have “open” position Indicators with limit stops.

Wrenches for valves, if required, shall either be of an integral design or consist of a head which fits on the stem and is designed to take an extended handle. The head design shall allow permanent attachment of the extended section if specified by the purchaser. Wrenches that are of integral design (not loose) shall not be longer than twice the face-to-face or end-to-end dimension unless otherwise agreed. Hand-wheel diameter(s) shall not exceed the face-to-face or end-to-end length of the valve or 1000 mm, whichever is smaller, unless otherwise agreed. Except for valve sizes DN 40 (NPS 1.) and smaller, spokes shall not extend beyond the perimeter of the hand-wheel unless otherwise agreed. If specified by the purchaser, the hand-wheel of the gearbox input shaft shall be provided with a torque-limiting device, such as a shear pin, to prevent damage to the drive train. Direction of closing shall be clockwise, unless otherwise specified.

Vendor shall be supplying flame proof / PESO, India approved electrical actuators along with the valves where ever specified.



The valves shall be Expanding gate valves with rising stem having two piece parallel expanding gates with resilient seats or twin seal plug valves having two independent resilient Retractable seats. The valve shall be designed to provide a tight mechanical seal and positive shut-off under high and low differential Pressures.

Rotation of the hand wheel/operator while opening shall lift / rotate the plug or gate without wiping the seals due to retracting action of the sealing slips so that during rotation / lifting of the plug / gate, clearance is maintained between the sealing slips and the valve body to minimize wear & tear of the seals. Rotation of the hand wheel/operator while closing shall lower the plug or gate after the sealing slips are aligned with the valve body and force the sealing slips against the valve body for positive closure independent of line operating pressure.

Motor operated valves shall be directly mounted with flame proof electric actuators / gear operators and delivered to the field as a complete unit.

**RELIEF SYSTEM:** The valves are to be provided with integral thermal relief system consisting of suitable valves & piping as per ratings of the valves to relieve the pressure build up in the internal body cavity when the valve is closed. Relief valves shall open at minimum 25 psi differential pressure or as specified by the manufacturer within limits as specified under clause 7.8 of API-6D and shall discharge to the upstream side of the valve. Thermal relief valves shall be externally placed in a way so that the same can be serviced without dismantling the main valve.

**BLEED VALVES:** Manually operated bleed valves are to be provided on the valve that can be

	<b>MRPL Marketing Terminal Project at Devangonhi, Bangalore</b>				
	<b>Marketing Infrastructure Projects, MRPL</b>				
	Part – C	<b>Specifications- Double Block &amp; Bleed VALVE</b>	Tender No. :		3200000495
	Section – C-3		Doc No.:		20005-GEN-I-SPE-6017
Subsection – C-3.60	Rev :		0		

opened to verify that the valves are not leaking when in the closed position. Suitable discharge piping with isolation valves and end plug / suitable adaptor for extension purpose, shall be provided so that the released liquid from each bleed valve can be contained locally. There shall be a provision to provide necessary instruments for remote checking of valve integrity in control room, if required by the user company.

Vendor shall quote in strict accordance with the valves data/ specification sheets, subject technical notes and all other enclosures to the tender document. Any deviation to be highlighted clearly in the deviation sheets enclosed.

Vendor shall supply valves along with auxiliaries, if any, such as gear operator, bypasses, drains etc. wherever specified in the specification sheets, subject notes and other enclosures to the tender document.

Valve body shall preferably have provision to drain any muck or dirt remains inside the Valve body, which can damage the seats.

The valve bodies shall be suitable for above ground open atmosphere Installation & shall be suitable for ambient Temperature range of -10°C to + 55°C & Relative humidity up to 100 %.

The valve shall be maintainable while being in position either by unbolting from Top or bottom or both. Valve design shall permit sealing slips to be replaced from the Top or bottom with the valve mounted in the piping. Vendor to mention the clearance required below the valve for on-line maintenance.

#### 4.5 DESIGN DETAILS



Valve shall be designed, manufactured, tested, inspected as per API- 6D/ISO 14313, ASME B16.34 & other manufacturing standards, design codes and standards (latest editions) indicated in latest edition of API-6D . Each valve shall bear API-6D monogram.

Metallic Pressure-containing and pressure controlling parts, including bolting, shall be designed with materials as per manufacturers" standards complying with minimum requirements as stipulated in clause 8 of API-6D.

All process-wetted parts, metallic and non-metallic, and lubricants shall be suitable for the commissioning fluids and service specified by the purchaser. Metallic Materials shall be selected so as to avoid corrosion and galling, which would impair function and/or pressure containing capability. Selection of elastomeric materials for valves intended for hydrocarbon gas service at pressures of PN 100 (class 600) and above shall consider the effect of explosive decompression.

The wetted parts shall be suitable coated with chrome coating / plating, Fluorocarbon coating & electro less nickel coating as required to enhance properties of materials for achieving longer life as per manufacturer"s standards & Approved QAP.

Design and calculations for pressure-containing elements shall be in accordance with an internationally recognized design code or standard with consideration for pipe loads, operating forces, etc. The choice of standard shall be in line with API-6D. Pressure & temperature ratings for

	<b>MRPL Marketing Terminal Project at Devangonithi, Bangalore</b>				
	<b>Marketing Infrastructure Projects, MRPL</b>				
	Part – C	<b>Specifications- Double Block &amp; Bleed VALVE</b>	Tender No. :		3200000495
	Section – C-3		Doc No.:		20005-GEN-I-SPE-6017
Subsection – C-3.60	Rev :		0		

ASME class-rated valves shall be in accordance with the applicable rating table for the appropriate material group in ASME B16.34. Material of construction of critical components of valves has been tabulated in Annexure-I.

Face-to-Face and end-to-end dimensions of valves shall be in accordance with Tables 2 to 6 of API-6D. Face-to-face and end-to-end dimensions for valve sizes not specified in Tables 2 to 6 shall be in accordance with ASME B16.10. Valve connections shall be ASME B16.5, Class 150 or Class 300, raised face flanged, as specified.

Positioning of cover must be provided to ensure correct Alignment of the valve disc part or an arrangement of parts for securing a valve in the open and/or closed position. Locking devices shall be designed to lock the valve in the open and/or closed position. The position of the obturator shall not be altered by dynamic forces of the passing flow. Valves fitted with manual or powered actuators shall be furnished with a visible indicator to show the open and the closed position of the obturator. For plug valves, the wrench and/or the position indicator shall be in line with the pipeline when the valve is open and transverse when the valve is closed. The design shall be such that the component(s) of the indicator and/or wrench cannot be assembled to falsely indicate the valve position. Valves without position stops shall have provision for the verification of open and closed alignment with the operator/actuator removed.

Travel stops shall be provided on the valve and/or operator and they shall locate the position of the obturator in the open and closed position. The travel stops shall not affect the sealing capability of the valve. Misalignment or improper assembly of components shall be prevented by suitable means, such as a dowel pin or fitting bolt, which ensures the correct location of manual or powered operators and stem extension assemblies.

The operating levers or handles on valves shall indicate, by their position, whether the valve is open or closed. The open position shall be indicated when the lever or handle points in a direction parallel to the flow through the valve. In addition, it shall be impossible to reverse the indicating position inadvertently during reassembly of the valve. Suitable marking shall be done on the valve to indicate flow direction.

Welding, including repair welding of pressure-containing and pressure- controlling parts shall be carried in line with clause 9 of API-6D.



Valve body/ bonnet shall be forged / cast as specified. Forgings are acceptable in place of casting but not vice versa. For expanding gate valves, fabricated body ( using steel plates) is acceptable

Material of construction of yoke shall be minimum equivalent to body/ bonnet material.

Stem shall be forged or machined from forged/ rolled bar. No casting is permitted.

Graphite material used for stem packing shall be chloride free i.e. leachable chlorides shall be less than 50 PPM. Stellite/ hard-facing by deposition, if required shall be min.1.6mm or as per manufacturer"s specifications.

Suitable gaskets are to be provided for body bonnet joints as per Manufacturer"s specifications in line with the requirement of standards. valves shall be supplied with antistatic arrangement as specified in API- 6D

	<b>MRPL Marketing Terminal Project at Devangonhi, Bangalore</b>				
	<b>Marketing Infrastructure Projects, MRPL</b>				
	Part – C	<b>Specifications- Double Block &amp; Bleed VALVE</b>	Tender No. :		3200000495
	Section – C-3		Doc No.:		20005-GEN-I-SPE-6017
Subsection – C-3.60	Rev :		0		

The MOVs are to be installed in an open area and the actuators shall be IP-65. The testing of complete assemblies of MOVs along with the actuators shall be carried out by the supplier at his works.

Ends of flanged valve of 22” size shall match corresponding flanges to MSS-SP44 unless otherwise specified.

For reduced bore valves, Minimum bore size shall be as per API-6D. Reduced-opening valves with a circular opening through the obturator shall be supplied with a minimum bore as follows, unless otherwise specified:

- valves DN 300 (NPS 12) and below: one size below nominal size of valve with bore according to Table 1 of API-6D;
- Valves DN 350 (NPS 14) to DN 600 (NPS 24): two sizes below nominal size of valve with bore according to Table 1 of API-6D;
- Valves above DN 600 (NPS 24): by agreement / as per standards of manufacture.

Reduced-opening valves with a non-circular opening through the obturator shall be supplied as per API-6D .

The valve shall be maintainable on line, without having a need to remove the valve body from the piping system. Valve seat shall be removable & replaceable without removing the valve from the manifold or pipe line. For gate valves, Valve gate, segment and seat rings shall be removable without removing the valve from the manifold or pipe line for ease of maintenance.



Gate/Plug design shall be such that it shall expand only in the closed position and provide a tight mechanical seal. Increases or decreases in line pressure shall not affect the mechanical sealing.

The design of stem protector and position indicator must be rugged and weatherproof. The position indicator shall be sealed at its exit point from the stem protector using a suitable mechanism. Operators, stem extensions and their interfaces shall be sealed to prevent ingress of external contaminants and moisture.

Valve stem packing shall be designed for easy on-line maintenance. The stem shall be of anti blowout design, permitting replacement of the stem seals with the valve in fully closed position. Valves shall be designed to ensure that the stem does not eject under any internal pressure condition or if the packing gland components and/or valve operator mounting components are removed. The stem integrity shall be ensured as per vendor’s design.

Manufacturer of the valve shall ensure bonding of slip seals for integrity & there shall be established procedures for ensuring QA/QC of the sealing materials & bonding. Viton material sourced from DUPONT / 3M shall only be accepted.

Drain, vent and sealant lines, if required as per design of the valve shall be provided and shall be extended by means of rigid pipe work, if necessary. The lines shall be fastened to the valve and/or extensions and terminate close to the stem extension top works, by agreement. Drain and vent lines shall :

	<b>MRPL Marketing Terminal Project at Devangonhi, Bangalore</b>			Page 261 of 269	
	<b>Marketing Infrastructure Projects, MRPL</b>				
	Part – C	<b>Specifications- Double Block &amp; Bleed VALVE</b>	Tender No. :		3200000495
	Section – C-3		Doc No.:		20005-GEN-I-SPE-6017
Subsection – C-3.60	Rev :		0		

- have a design pressure not less than the rated pressure of the valve on which they are installed;
- be capable of withstanding the hydrostatic shell test pressure of the valve
- be designed in accordance with a recognised design code;
- be suitable for blow-down operation, where applicable.

Sealant lines for stem sealant injection, if required shall have a design pressure not less than the greater of the pipeline valve rated pressure and the injection pressure. If not specified by the purchaser, the manufacturer shall advise the maximum injection pressure for the system. The size of the sealant lines shall be by agreement. Prior to assembly, the internal bores of sealant lines shall be clean and free from rust and any foreign particles.

Drain and vent block valves shall be provided, if specified, shall have a rated pressure not less than the valve on which they are installed and be suitable for blow-down operation.

Bypass, drain and vent connections and plug entries shall be drilled and threaded unless otherwise specified / as per manufacturing standards.

Thread profiles shall be tapered unless otherwise agreed. Tapered threads shall be capable of providing a seal and comply with ASME B1.20.1.

If the use of parallel threads is specified, the connection shall have a head section for trapping and retaining a sealing member suitable for the specified valve service. Parallel threads shall comply with ISO 228-1.



Minimum sizes shall be in accordance with Table 7 of API-6D.

The pressure as determined in accordance with clause 7.2 of API-6D shall be the maximum pressure differential (MPD) at which the valve is required to be opened by the lever, gearbox or actuator. The manufacturer shall provide the following data to the purchaser in technical bid:

- flow coefficient Cv or Kv;
- breakaway thrust or torque for new valve;
- maximum allowable stem thrust or torque on the valve and, if applicable, the maximum allowable input torque to the gearbox;
- Number of turns for manually operated valves.

Drive trains: The design thrust or torque for all drive train calculations shall be at Least two times the breakaway thrust or torque to allow for thrust or torque increase in service due to infrequent cycling and the adverse effect of debris. Allowable Tensile stresses in drive train components, including stem extensions, shall not exceed 67 % of SMYS when delivering the design thrust or torque. Shear, torsion and bearing stresses shall not exceed the limits specified in ASME Code Section VIII, Division 2, Part AD- 132, except that design stress intensity values, Sm, shall be 67 % of SMYS. These stress limits do not apply to the components of rolling- element or other proprietary bearings or high bearing strength capable materials that are included in the drive train where manufacturer's recommendations or limits derived from tests and service experience apply. These limits shall be justified in design documents, if requested.

The drive train shall be designed such that the weakest component is outside the Pressure

	<b>MRPL Marketing Terminal Project at Devangonhi, Bangalore</b>				
	<b>Marketing Infrastructure Projects, MRPL</b>				
	Part – C	<b>Specifications- Double Block &amp; Bleed VALVE</b>	Tender No. :		3200000495
	Section – C-3		Doc No.:		20005-GEN-I-SPE-6017
Subsection – C-3.60	Rev :		0		

boundary. A strength efficiency factor of 0,75 shall be used for fillet Welds .

Note — If an actuator or operator can deliver a thrust or torque that is greater than the design thrust or torque of the drive train, such a thrust or torque can result in permanent deformation or failure of drive train Components. Hence careful selection shall be carried out for actuator.

Deflections of the extended drive train shall not prevent the obturator from reaching the fully closed or fully open position. For all valves, attention shall be paid to deflection and strain. Adherence to the allowable stress limits of Design codes alone might not result in a functionally acceptable design.

The manufacturer shall demonstrate, by calculation or test, that under loads resulting from design pressure and any defined pipe or external loads, distortion of the obturator or seat does not impair functionality or sealing.

Valves of size DN 200 (NPS 8) and larger shall be provided with lifting points. The manufacturer shall verify suitability of the lifting points. The valve manufacturer shall verify the suitability of the lifting points for the complete valve and operator assembly.

Materials of construction for critical valve components shall be as given below in table A & B

TABLE –A (DBB PLUG VALVES)

S.NO.	DESCRIPTION	SPECIFICATION	VENDORS CONFIRMATION
4	Body	Cast Carbon Steel ASTM A 216 WCC /WCB	
5	Bonnet / Lower plate	Cast Carbon Steel ASTM A516 Gr. 70 / ASTM A 216 WCC/WCB	
6	Plug	Cast Carbon Steel ASTM A 216 WCC/WCB, case hardened and 0.003 in. ENP	
7	Stem	AISI 4140 (1.5 mm steliting) / ASTM-A479 TY 410 (0.03in. ENP)	
8	Slips	Cast Ductile iron ASTM A 536-80-55-06/ A395 Gr. 60-40-18	
9	Gasket	Flexible Graphite.	
10	Gland packing	Flexible Graphite	
11	Body Fire seals	Graphite	
12	Slip seals	Viton (Dupont / 3M)	
13	Bolts/Nuts	ASTM A193 Gr.B7 /ASTM A 194 Gr2H	
14	Tubing / connectors /needle valves	SS-316	



TABLE -B (DBB GATE VALVES)

S. No	DESCRIPTION	SPECIFICATION	VENDORS CONFIRMATION
1	Body	ASTM A 516 GR. 70 / ASTM A 216 GR. WCB/WCC	
2	Bonnet	ASTM A 516 GR. 70 /ASTM A 216 GR. WCB/WCC	
3	Bolts/Nuts	ASTM A193 Gr B7/ASTM A 194 Gr2H	
4	STEM	AISI 4140 (1.5 mm stelling / ENP)	
6	STEM SEAL	GRAFOIL TYPE TO COMPLY WITH FIRE SAFE REQUIREMENT	
7	GATE / SEGMENT	A216WCC/ WCB or ASTM A 516(ENP)	
8	SEAT ASSEMBLY	ASTM A 516-GR.70 OR A105	
9	Centralised arm	ASTM A 516-GR.70(ENP)	
10	SEAT SEAL	VITON (DUPONT/3M)	
11	O-RING SEALS	VITON GFLT	
12	PRESSURE RELEASE VALVE	SS-316	
13	Packing	Graphite	
14	End Flanges	ASTM A 105,125AARH	
15	Tubing / connectors /check /needle valves	SS-316	

All applicable codes and standards for design, materials, manufacture, testing, inspection etc. shall be of latest editions. Vendor to list all the specifications / standards applicable.

#### 4.6 QUALITY CONTROL / INSPECTION & TESTING

Valve shall be subject to all the tests and checks required as per quality control requirements of clause 10.0 & testing requirements of clause 11.0 of API-6D & other relevant standards & as per the QAP specified in the tender document. However vendor shall submit their detailed QAP in line with the specifications stipulated in this tender document. NDE tests shall be carried out in line with

	<b>MRPL Marketing Terminal Project at Devangonhi, Bangalore</b>				
	<b>Marketing Infrastructure Projects, MRPL</b>				
	Part – C	<b>Specifications- Double Block &amp; Bleed VALVE</b>	Tender No. :		3200000495
	Section – C-3		Doc No.:		20005-GEN-I-SPE-6017
Subsection – C-3.60	Rev :		0		

Annexure-A of API-6D. Vendor shall be deploying services of TPIA for witnessing tests as per approved QAP at their (Vendor"s) cost.

Purchaser, at its discretion may depute their representatives at their own cost to witness critical tests at manufacturing works in addition to TPIA.

Chemical composition and mechanical properties shall be checked as per relevant material standards and this specification, for each heat of steel used.

Non-destructive examination of individual valve material and components consisting of, but not limited to castings, forgings, plate and assembly welds shall be carried out by the Manufacturer in line with API-6D.

The manufacturer shall submit a certificate covering the testing of the valves and Certifying the materials of construction used in the valves, according to API 6D and other relevant standards of Latest edition.

Vendor shall submit type test certificates for fugitive emission tests carried out in accordance with TU-LUFT / ISO 15848 / US Clean air act or equivalent standards.

Valves shall be tested prior to shipment in line with the requirements of API-6D and agreed QAP. Testing shall be performed in the sequence detailed in API-6D. Pressure testing shall be carried out before coating of the valves. Test fluid shall be fresh water or, by agreement, light-weight oil having a viscosity not exceeding that of water. Water used for testing shall contain a corrosion inhibitor.

Valves shall be tested with the seating and sealing surfaces free from sealant except where the sealant is the primary means of sealing. A secondary sealant system, if provided, shall not be used before or during tests.

Supply pressure shall be stabilized prior to the start of pressure testing and shall be held for the minimum test durations listed in Tables 9, 10 and 11 of API-6D.

Fire type-testing certification of the design shall be provided. The fire- resistance design of valves shall be qualified by fire type-testing in accordance with ISO 10497. Fire resistance designs already qualified to ISO 10497, API 6FA, API 6FC, API 6FD or API 607 are also acceptable as per stipulations of API-6D.

**Hydrostatic shell test:** Valve ends shall be closed off and the obturator placed in the partially open position during the test. If specified by the purchaser, the method of closing the ends shall permit the transmission of the full-pressure Force acting on the end blanks to the valve body. If present, external relief valves shall be removed and their connections plugged. The test pressure shall be 1,5 or more times the pressure rating determined in accordance with 7.2 for Material at 38 °C (100 °F). The duration shall not be less than that specified in Table 10. No visible leakage is permitted during the hydrostatic shell test.

After hydrostatic shell testing, external relief valves shall be fitted to the valve. The connection to the valve body shall be tested at 95 % of the set pressure of the relief valve for 2 min for valve sizes up to and including DN 100 (NPS 4), and 5 min for valve sizes DN 150 (NPS 6) and larger. The relief-valve connection shall be free of visible leakage during this period. All the valves are required to be tested for hydrostatic shell test.



**Hydrostatic seat test:** The test pressure for all seat tests shall not be less than 1.1 times the pressure rating determined in accordance with clause 7.2 of API-6D for material at 38 °C (100 °F). The test duration shall be in accordance with Table 11. The test procedures for various types of block valve shall be in line with para 11.4.4. of API-6D

**Acceptance criteria:**

Leakage for soft-seated valves shall comply with the requirements of API 598. API-598 states for shell and backseat tests, no visible leakage is permitted. If the fluid is a liquid, there shall be no visible evidence of drops or wetting of the external surfaces (no visible leakage through the body, body liner, if any, and body-to-bonnet joint and no structural damage).



If the test fluid is air or gas, no leakage shall be revealed by the established detection method. For both the low-pressure closure test and the high- pressure closure test, visual evidence of leakage through the disk, behind the seat rings, or past the shaft seals (of valves that have this feature) is not permitted (Plastic deformation of resilient seats and seals is not considered structural damage).

The allowable rate for leakage of test fluid past the seats, for the duration of the tests, is listed in the following table:

Valve Size	All Resilient Seated Valves	All Metal-Seated Valves (except Check Valves)		Metal-Seated Check Valves	
		Liquid Test (drops/min)	Gas Test (bubbles/min)	Liquid Test (drops/min)	Gas Test (bubbles/min)
<= 2"	0	0 (b)	0 (b)	(c)	(d)
2.5" - 6"	0	12	24	(c)	(d)
8" - 12"	0	20	40	(c)	(d)
>= 14"	0	28	56	(c)	(d)

Where:

- 1 milliliter is considered equivalent to 16 drops
- There shall be no leakage for the minimum specified test duration. For liquid test, 0 drop means no visible leakage per minimum specified test duration. For gas test, 0 bubble means less than 1 bubble per minimum specified test duration.
- The maximum permissible leakage rate shall be 0.18 cubic inch (3 cubic centimeters) per minute per inch of nominal pipe size.
- The maximum permissible leakage rates shall be 1.5 standard cubic feet (0.042 cubic meter) of gas per hour per inch of nominal pipe size.

	<b>MRPL Marketing Terminal Project at Devangonhi, Bangalore</b>				
	<b>Marketing Infrastructure Projects, MRPL</b>				
	Part – C	<b>Specifications- Double Block &amp; Bleed VALVE</b>	Tender No. :		3200000495
	Section – C-3		Doc No.:		20005-GEN-I-SPE-6017
Subsection – C-3.60	Rev :		0		

All the valves are required to be tested for hydrostatic seat test

Additional seat testing:

Since the valves are expected to have the functionality for the valve to be that of double-block-and-bleed (DBB) & double-isolation-and-bleed (DIB-1), the test described in Clause B.10 & B.11 of API-6D shall be performed. 10 % of the valves of all sizes & types are required to be tested for Additional seat testing.

Test of thermal relief valve: The external relief valve shall be set and certified to relieve at the specified pressure either by the relief-valve supplier or the valve manufacturer for all the valves .

Testing of drain, vent and sealant injection lines, if provided: drain and vent Lines shall be subject to a hydrostatic test with all the valves.

Anti-static testing: The electrical resistance between the obturator and the Valve body and between the stem/shaft and the valve body shall be measured using a direct-current power source not exceeding 12 V. The resistance shall be Measured on dry valves before pressure testing and shall not exceed 10 ohm 5 % of the valves of each size & type shall be tested for Anti-static testing.

Torque/thrust functional testing: The maximum torque or thrust required to Operate gate or plug valves shall be measured at the pressure specified by the purchaser for critical valve operations. Thrust and torque testing shall be performed following hydrostatic shell testing and, if specified, prior to any low-pressure gas seat testing. The measured torque or thrust results shall be recorded and shall not exceed the manufacturer"s documented breakaway torque/thrust. 1 % of the valves (min.1) of each size & type shall be tested.

Drive train strength test: The test torque shall be the greater of

- a) Twice the manufacturer's predicted break-away torque/thrust, or
- b) Twice the measured break-away torque/thrust.

The test torque shall be applied with obturator blocked for a minimum time of 1 min.

NOTE:



- a) For gate valves, the thrust can be tensile or compressive, whichever is the most stringent condition.
- b) The test shall not cause any permanent visible deformation of the drive train.
- c) For plug valves, the total torsional deflection of the extended drive train when delivering the design torque shall not exceed the overlap contact angle between the seat and obturator.
- d) 1 % of the valves (min.1) of each size & type shall be tested for Drive train strength test.

## 5. DOCUMENTATION

Vendor shall arrange to retain documents in his works as stipulated in API-6D.

In addition, Vendor shall arrange to submit following documents along with the consignment:

- a) Detailed dimensioned, cross section drawing of each size of valve being offered with parts/ material lists, weight etc. as manufacturer"s / API / Other relevant applicable standard.
- b) Drawings for valves with accessories like gear operator, extension bonnet, extended stems with stands bypass etc. giving major salient dimensions.

	<b>MRPL Marketing Terminal Project at Devangonhi, Bangalore</b>			Page 267 of 269	
	<b>Marketing Infrastructure Projects, MRPL</b>				
	Part – C	<b>Specifications- Double Block &amp; Bleed VALVE</b>	Tender No. :		3200000495
	Section – C-3		Doc No.:		20005-GEN-I-SPE-6017
Subsection – C-3.60	Rev :		0		

- c) Material test certificates (physical property, chemical composition & heat treatment report, radiography etc.) of the pressure containing parts & for the other parts shall also be furnished for verification during inspection.
- d) Following supplementary documentation is required to be provided in line with API-6D as given below:
- NDE records;
  - Hardness test report on pressure-containing parts;
  - Heat treatment certification records (e. g. charts);
  - Pressure test / Leak test (Valve seat & Fugitive) & other test reports, (Including pressure, test Duration, test medium and Acceptance Criteria);
  - coating/plating certification;
  - Fire type-test certificates;
  - Material inspection certificates in accordance with ISO 10474 or EN 10204, as applicable (the purchaser shall specify the type of Certification, and for which parts, when ordering);
  - Design verification by certification body/agency;
  - Installation, operation and maintenance instructions/manuals;

## 6. MARKING

Valve markings, symbols, abbreviations etc. shall be in accordance with Table 12 of API-6D. Vendor's name, valve rating, material designation, nominal size, direction of flow (if any) etc. as specified in the table 12 of API-6D shall be integral on the body.

Body/cover/closure stamping shall be performed using a low-stress die- stamp, rounded "V" or Dot Face type. Each valve shall be provided with an austenitic stainless steel nameplate securely affixed and so located that it is easily accessible. The marking on the nameplate shall be visually legible.

Each valve shall be marked with API-6D Monogram



## 7. PAINTING/PREPARATION OF SHIPMENT

All non-corrosion-resistant valves shall be coated externally in accordance with manufacturer's standards, unless otherwise agreed.

Carbon steel valves shall be painted with two coats of inorganic zinc silicate primer ( Min. 35 micron per coat) .Flange faces, weld bevel ends and exposed stems shall not be coated.

Parts and equipment that have bare metallic surfaces shall be protected with a rust preventative that can provide protection at temperatures up to 50 °C (122 °F).

After testing, all valves shall be drained and dried thoroughly. Valve shall be suitably painted as above / vendor's standard approved specifications.

	<b>MRPL Marketing Terminal Project at Devangonhi, Bangalore</b>				
	<b>Marketing Infrastructure Projects, MRPL</b>				
	Part – C	<b>Specifications- Double Block &amp; Bleed VALVE</b>	Tender No. :		3200000495
	Section – C-3		Doc No.:		20005-GEN-I-SPE-6017
Subsection – C-3.60	Rev :		0		

Flanged, threaded and welding ends shall be blanked off to protect the gasket surfaces, welding ends and valve internals during shipment. Machined surfaces shall be protected against corrosion during shipment and storage.

Valves shall be protected from rust, corrosion and any mechanical damage during Transportation, shipment and storage. The packages shall be sea-worthy when required to be transported by ships.

Rust preventive on machined surfaces shall be easily removable with a Petroleum solvent.

Each end of valves shall be protected with the following materials:

- Flange Face : Wood, Wood fiber, Metal or Plastic cover
- Beveled End : Wood, Wood fiber, Metal or Plastic cover SW & SCRD End : Plastic Cap

The ends shall be securely attached to the valve ends by bolting, steel straps, Steel clips or suitable friction-locking devices. The design of the covers shall Prevent the valves from being installed unless the covers have been removed.

A warning label shall be attached to the protective cover with instructions to remove, prior to installation, material from inside the valve that secures or supports the disc

Each valve shall be wrapped in a polythene / impervious sheet & packed separately in wooden crate, properly secured to prevent damage during transportation. Each box shall be clearly marked, valve size, location of dispatch, Purchaser company's name, UP marking & —fragilell warning.

The valve boxes shall be put in a large container for transportation as per manufacturer's standards separately for each Purchaser Company & location of dispatch.

The Plug valves shall be shipped in the fully open position. While, gate valve shall be shipped with the gate in the fully closed position.



Valves of size DN 200 (NPS 8) and larger shall be provided with lifting points, Unless otherwise agreed. The manufacturer shall verify suitability of the lifting points.

## 8. SPARES & SPECIAL TOOLS

- a) Vendor shall submit list of standard spares of valves & actuators along with unit rates with validity for 2 years.
- b) Vendor shall submit list of special tools, if required for maintenance of valves along with unit rates with validity of 2 years.

## 9. COMMISSIONING ASSISTANCE & WARRANTIES

Bidder shall depute OEM commissioning engineer for the commissioning of DBBVs. The representative shall ensure that the valve is commissioned successfully.

	<b>MRPL Marketing Terminal Project at Devangonhi, Bangalore</b>			Page 269 of 269	
	<b>Marketing Infrastructure Projects, MRPL</b>				
	Part – C	<b>Specifications- Double Block &amp; Bleed VALVE</b>	Tender No. :		3200000495
	Section – C-3		Doc No.:		20005-GEN-I-SPE-6017
Subsection – C-3.60	Rev :		0		

Vendor shall provide warranty for the performance of valves for 18 months from date of dispatch or 12 months from date of installation, whichever is later subject to not exceeding 24 months from date of dispatch.

Manufacturer shall have / develop adequate service support in India to provide technical after sales service in India with in 48 hrs. Notice & shall guarantee supply of parts, services for at least 10 years for all valves supplied by way of an undertaking.