



MANGALORE REFINERY & PETROCHEMICALS LTD.

(A subsidiary of Oil & Natural Gas Corpn. Ltd – ONGC)

Regd. Office: Kuthethoor P.O., Via: Katipalla, Mangaluru-575030 (India)

Phone: 0091-824-2270400 Fax: 0091-824-2271239

E-PUBLIC Tender No.: 3200000464 Date: 10.11.2020

E-OPEN TENDER

**ENGINEERING, PROCUREMENT AND CONSTRUCTION MANAGEMENT
(EPCM) SERVICES FOR INSTALLATION OF LPG AMINE ABSORBER
SYSTEM IN PFCC UNIT AT MRPL, MANGALURU**

Tender Download Start Date	10.11.2020
Tender Download End Date & Time	30.11.2020 ; 15.00 Hrs
Pre bid Meeting	18.11.2020 ; 11:15 Hrs
Bid Closing date & Time	30.11.2020 ; 15.00 Hrs
Un priced Bid Opening date & Time	30.11.2020 ; 15.30 Hrs

In view of recent Govt. notification and changes on MSME classification, all MSE's bidders are requested to register again on Udyam Registration portal (earlier known as UAM) as the existing registration is valid only upto 31.03.2021.

MRPL has discontinued publication of Tender Advertisements through newspapers or any other print media.

The complete Tender/Bidding document is available for view/download on MRPL website <http://www.mrpl.co.in> as well as on <https://eprocure.gov.in/cppp/>

Further replies to pre-bid queries, all updates, Corrigendum, Addendum, Amendments, Extension in last date of submission of bid, Clarifications etc.,(if any) to the Tender/Bidding document will be hosted on above indicated websites only.

Bidders should regularly visit above indicated website to keep themselves updated.

INDEX

Sl. No.	Title
1	Notice Inviting Bid (NIT)
2	Instruction to Bidder(s) (ITB)
3	Proposal Forms
4	Form of Contract & Conditions of Contract
5	Exhibits
	Exhibit 1 - Project Description
	Exhibit 2 - Scope of Services, Special Conditions of Contract (SCC)
	I) Annexure I to SCC - Specification For Documentation Requirements II) Annexure II to SCC - MRPL Contract Worker Safety Policy III) Annexure III to SCC - Minimum Manpower Requirement - Mobilization of Key Consultant Personnel
	Exhibit 3 - Completion Schedule
	Exhibit 4 - Price Reduction Schedule & Penalties
	Exhibit 5 - MRPL' s Obligations
	Exhibit 6 - Exclusions From Consultant's Scope
	Exhibit 7 - Warranties & Guarantees
	Exhibit 8 - General Conditions of Contract (GCC)
	Exhibit 9 - Remuneration, Contract Price & Terms Of Payment
	Exhibit 10 - BG Format for EMD & PBG
	Exhibit 11 – Summary of Schedule of Prices



NOTICE INVITING TENDER (NIT)

For

**ENGINEERING, PROCUREMENT AND CONSTRUCTION
MANAGEMENT (EPCM) SERVICES FOR INSTALLATION OF
LPG AMINE ABSORBER SYSTEM IN PFCC UNIT AT MRPL,
MANGALURU.**

Tender No.: 3200000464

(DOMESTIC COMPETITIVE BIDDING)



1.0 INTRODUCTION

Mangalore Refinery and Petrochemicals Limited (MRPL) a government of India schedule A, CPSE and a subsidiary of Oil and Natural Gas Corporation Limited (ONGC) is a State of Art Grass Root Petroleum Refinery located in a beautiful hilly terrain, north of Mangalore city, in Dakshina Kannada region, Karnataka State. The Refinery is operating a 15.25 MMTPA fuels refinery at Mangalore and has got a versatile design with high flexibility to process Crudes of various API with high degree of automation. The Refinery complex is integrated to Aromatic Complex and designed to produce 900,000 TPA of Paraxylene.

MRPL has high standards in refining and environment protection matched by its commitments to society. MRPL has also developed a Green Belt around the entire Refinery with plant species specially selected to blend with the local flora.

2.0 REQUIREMENT OF LPG AMINE ABSORBER SYSYEM

MRPL has installed Petrochemical Fluidized Catalytic Cracking (PFCC) unit with a capacity of 2.2 MMTPA. The unit was commissioned in 2014. The process technology is licensed by M/s. Technip Stone and Webster. While processing feed with higher Sulphur content in PFCCU, higher H₂S is expected in LPG stream. A New LPG Amine Treatment unit shall be installed to remove the hydrogen sulfide present in the LPG and to minimize the spent caustic generation in existing caustic treatment system.

3.0 BRIEF SCOPE OF WORK:

The scope of work broadly includes detailed Engineering, Procurement and Construction Management, Mechanical Completion and Commissioning of the unit. This shall include but not limited to Project Management, Detailed Engineering, Procurement Services, Inspection and Expediting, Construction Management, Safety and Supervision of unit. The scope includes but not limited to Civil, Structural, Architectural, UG Piping, Mechanical, Piping, Electrical, Instrumentation, Insulation, Painting, Assistance in obtaining statutory clearance, Assistance during Pre-commissioning, Startup, Commissioning and Performance Test of the Unit.



ENGINEERING, PROCUREMENT AND CONSTRUCTION MANAGEMENT (EPCM) SERVICES FOR INSTALLATION OF LPG AMINE ABSORBER SYSTEM IN PFCC UNIT AT MRPL, MANGALURU

4.0 SILENT FEATURES OF THE BIDDING DOCUMENT:

SL.No.	Description	Details
1	Tender Number	3200000464
2	Brief Description of the Tender	E – OPEN TENDER FOR ENGINEERING, PROCUREMENT AND CONSTRUCTION MANAGEMENT (EPCM) SERVICES FOR INSTALLATION OF LPG AMINE ABSORBER SYSTEM IN PFCC UNIT AT MRPL, MANGALURU.
3	Tender Type	Open- domestic
4	Bid Type	Two Bid
5	Mode	Electronic Procurement System (EPS)
6	Tender Document download start date	10.11.2020
7	Bid Closing date/Time	30.11.2020 @ 15.00 Hrs (IST)
8	Date / Time of Technical Bid Opening	30.11.2020 @ 15.30 Hrs (IST)
9	Pre bid Conference	Applicable on 18.11.2020 @ 11.15 Hrs. Venue : Nethravathi building, 1 st floor (near E gate) Mangalore Refinery and Petrochemicals Ltd, Mangaluru -575030, Karnataka, India
10	EMD	Applicable: ₹ 17,50,000/- (In words: Seventeen Lakh Fifty thousand only)
		EMD (BG or DD) drawn in favour of MRPL Mangaluru, to be sent directly to Projects Department, Nethravathi building, MRPL, Kuthethoor PO, Via Katipalla, Mangaluru. Please super-scribe on envelope “EMD for Tender No. 3200000464 dated 10.11.2020”
11	Duration of Contract / Contract Period	Mechanical Completion Within 24 (Twenty four) Months from date of issue of LOA
12	Purchase Preference for Micro & Small Enterprises(MSE)	Applicable
13	Item(s) Splittable	No
14	Relaxation in BQC (Financial Turnover & Past Experience) for Start-up Companies	Not Applicable
15	Offer Validity	120 days from Bid closing Date
16	Price Reduction Clause	Applicable
17	Security deposit	Applicable @ 10% of the Order value
18	Defect Liability	Applicable
19	Integrity pact	Applicable



ENGINEERING, PROCUREMENT AND CONSTRUCTION MANAGEMENT (EPCM) SERVICES FOR INSTALLATION OF LPG AMINE ABSORBER SYSTEM IN PFCC UNIT AT MRPL, MANGALURU

20.A	Contact details – Technical Queries	Mr. GIRISH M. PAI Email Id: gmpai@mrpl.co.in Ph. No: 0824-288 2050
B	Commercial Queries	Section Incharge: Mr. SANJAY M. MESWANI Email: sanjay@mrpl.co.in Ph. No: 0824-288 2047 Dealing Officer: Mr. K. HARIKUMAR Email: hari_kumar@mrpl.co.in Ph. No: 0824-288-2070
21	Contact person For Queries related to E-tendering	Mr. Dilip Ranganath, Email: eps@mrpl.co.in Phone No. 0824-288-2248 (Dealing officer / Section In-charge details as mentioned above may also be contacted).
22	Alternate Contact details for E-Tendering	Mr. Mohan Kumar / Mr. Prabhuswamy, mohan@antaressystems.com / prabhuswamy@antaressystems.com Phone No. 080 – 49352000
23	Address to submit the tender document (in case of Manual Tender / Other Relevant Documents)	Projects Department, II floor, Nethravathi Building, Mangalore Refinery and Petrochemicals Ltd, Mangalore -575030, Karnataka, India (Please mention tender number on the envelop)

Contact details & Address for Site visit.

Contact Details	Address
Mr. GIRISH M. PAI Email Id: gmpai@mrpl.co.in Ph. No: 0824-288 2050	Mangalore Refinery & Petrochemicals Limited. (A subsidiary of Oil & Natural Gas Corpn. Ltd – ONGC) Kuthethoor P.O., Via: Katipalla, Mangaluru-575030 (India)

Important information to be noted by the bidders:

- Bidders are requested to visit MRPL website <http://mrpl.co.in> regularly to keep themselves updated. Any Revision, clarification, addendum, corrigendum, for replies to queries raised during pre-bid meeting Time / Due date extension etc., (if any) , to this tender would appear on the above websites only and & will not be published on any other Media /Press.
- In case of E-Tenders, the Technical & Price Bid Formats should be downloaded, filled & uploaded in the EPS portal (<https://www.tenderwizard.com/MRPL>).

Bid-Qualification Criteria & Bid Evaluation Criteria

1.0 Bid-Qualification Criteria:

A) Financial Turnover:

a	Average Annual Financial Turnover during the last 3 years ending 31st March of the previous financial year should be at least	₹ 300 Lakhs
b	Net worth of the bidder as per latest audited annual financial result shall be positive.	

B) Past Experience:

The Bidder should have experience of having successfully completed similar work during the last **10** years ending last day of the month previous to the one in which tenders are invited, which experience should be any one of the following:

a	Three similar completed works, each costing not less than	₹ 400 Lakhs
b	Two similar completed works, each costing not less than	₹ 500 Lakhs
c	One similar completed works, costing not less than	₹ 800 Lakhs

Note:

1. **“Similar work”** is defined as Project Management Consultancy (PMC) services or Engineering, Procurement and Construction Management (EPCM) Consultancy services for a Hydrocarbon Processing unit in a Petroleum Refinery / Oil and Gas / Petrochemical / Fertilizer Plant.
2. All above indicated amounts are exclusive of Service Tax / GST.
3. **Relaxation to MSE/Start-up bidders :**
 - a. Bid-qualification criteria with respect to Prior Turnover and Prior experience (on the amount) may be relaxed for Micro and Small Enterprises (to the extent of 15%) as per GOI guidelines subject to meeting of quality and technical specifications. (For example, if BQC value applicable to other than MSE bidders is Rs 100/-, the same shall be Rs 85/- for MSE bidders).
 - b. No relaxation in Bid-Qualification criteria with respect to Prior Turnover and Prior experience for start up bidders for this tender, due to public safety, health, critical security operations & equipment etc.

C) Other Criteria:

1. The Bidder shall be a Government Organization / Public Sector Undertaking / Registered Partnership Firm / Limited Company / Private Limited / Limited liability partnership / LLC or equivalent and shall be in existence as on date of NIT. Relevant documents of registration should be submitted as part of the proposal.



ENGINEERING, PROCUREMENT AND CONSTRUCTION MANAGEMENT (EPCM) SERVICES FOR INSTALLATION OF LPG AMINE ABSORBER SYSTEM IN PFCC UNIT AT MRPL, MANGALURU

2. Bidders who have been issued and executed orders for any Services/works in MRPL during the last 10 years shall provide Completion Certificate from MRPL, else a declaration shall be given by the bidder that they have not executed such work orders in MRPL in the said period.
3. Bidders who have been issued orders/contract for any services/works by MRPL during the last 10 years and the same work is in progress and not completed till the last day of the month previous to the one in which tenders are invited, Bidder shall give declaration to regarding the same, giving full details of Order/Contract, Contract Delivery date and reasons for the order/contract not completed till the last day of the month previous to the one in which the tenders are invited. MRPL reserves the right to access the performance of such Contracts/Orders of such internally.
4. MRPL is entitled to contact the firm which has provided completion certificate by whatsoever means required to verify the authenticity.
5. Experience of only the Bidding Entity shall be considered, In-house experience (where for the past experience referred for qualification, the contractor and the Owner belonging to the same organization as on date of the past experience completion date) shall not be considered as a valid experience for the purpose of qualification.
6. A bid made by a wholly owned Indian Subsidiary of a Foreign Company will also be considered provided the Parent Company meets the BQC. In such case, the following shall be complied and necessary documents from parent company shall be submitted.
 - a) The work under consideration shall either be executed by the Parent company or shall be executed under the supervision and back-up of the Parent Company.
 - b) The Parent Company shall furnish a corporate undertaking to be jointly and severally responsible with the Indian subsidiary for due, proper and timely performance of the contract and discharge of liabilities of its Indian Subsidiary in the event of award of work to its Indian Subsidiary.
7. The bidder should not be under a black-list / holiday list of any state / central government department or undertaking (including PSUs). Bidder shall give a declaration to this effect.
8. Bids submitted on Consortium or Unincorporated Joint-venture / Joint bid basis shall not be accepted for this tender.
9. All offers shall be submitted in INR (Indian Rupee) only. Bids Submitted in any other currency shall be rejected. Bidder shall submit a confirmation to this effect with the Techno-commercial bid.

Note : Bidder is required to provide the following documentary proof in support of meeting Bid - Qualification Criteria along with their technical bid:

1. Annual reports containing Audited balance sheets and Profit and Loss statement, in support of their fulfilling the qualification criteria. (In case the last Financial closing date is within 9 months of bid due date and audited annual report of immediately preceding Financial year is not available, bidder has the option to submit the financial details of the three previous years immediately prior to the last financial year. Otherwise, it is compulsory to submit the financial details of the immediate three preceding financial years).
2. Bidder shall furnish documentary evidence covering similar work mentioned above, but not be limited to:
 - a. Copies of work orders with relevant pages of contract and SOR

- b. Proof of Completion / completion certificate indicating value of work completed against above order, in support of their fulfilling the qualification criteria.
3. Other relevant documentary evidence for all the above-mentioned criteria (As applicable for the tender).
4. All documents furnished by bidder in support of meeting the experience criteria of BQC shall be

EITHER

“Duly certified by Statutory Auditors of the Bidder or a practicing Chartered Accountant (not being an employee or a director or not having any interest in the bidder(s) company/firm) where audited accounts are not mandatory as per law.

OR

Duly notarized by any Notary Public in the bidder’s country”

5. MRPL reserves the right to complete the evaluation based on the details furnished without seeking any additional information.

D) Bid Evaluation Criteria (BEC):

1. The bidder should accept in Toto the Technical specification and Scope of work given in the Tender with no deviations as per clauses of the tender document.
2. Techno-Commercially accepted bids will be evaluated commercially on Overall L-1 basis, i.e., lowest landed cost to MRPL.
3. The Lumpsum Price quoted by bidders in Price bid format (FORM SP-0) and Optional manpower rates quoted by bidder in Price Bid Format (FORM SP-1) shall be considered for the purpose of evaluation along with the GST quoted and commercial Loading if any.
4. In case of Tie between two or more bidders at L-1 Position, all the L-1 bidders shall be asked to submit discount over previous quoted rate in a sealed envelope (Priced). The process shall be repeated till final L-1 position is established

E) Rejection Criteria:

1. Bids received after the due date and time of bid submission shall be summarily rejected.
2. Bids without EMD: Bids received without / with insufficient EMD (in original with the Technical Bid), before the bid closing date and time shall be summarily rejected. However, Govt. Dept. / PSUs / firms registered with NSIC / MSE (Micro and Small Enterprise), vendors registered with District Industries Centre (DIC) / any other body specified by Ministry of MSME (MoMSME) / Udyog Aadhaar Memorandum issued by MoMSME, Start-ups are exempted from submission of EMD. Such bidders shall submit relevant documentary proof towards exemption, along with technical bid of the tender.
3. Offer sent without having the prescribed bidding document of MRPL, non-adherence to technical / commercial terms and conditions, Un-priced bid and Price bid not in the prescribed format, incomplete bids and bids with deviations to the tendered scope of work shall be liable for rejection.
4. Non-compliance to any of BQC / BEC will be liable for rejection.



**ENGINEERING, PROCUREMENT AND CONSTRUCTION MANAGEMENT (EPCM) SERVICES FOR
INSTALLATION OF LPG AMINE ABSORBER SYSTEM IN PFCC UNIT AT MRPL, MANGALURU**

5. Bidder's failure to enter into Integrity Pact as applicable for the Tender along with the bid duly signed shall be liable for rejection.
6. If technical bid and price bid is submitted together.
7. Bids found to have been submitted with falsified / incorrect information.
8. If Bidder is in the Holiday / Blacklist of any CPSU / State PSU / Central or State Government Undertaking. Bidder shall give a self-declaration to this effect.
9. Bids submitted on Consortium or Unincorporated Joint-venture / Joint bid basis shall not be accepted.
10. Offers not meeting statutory requirement are liable for rejection.



INSTRUCTION TO BIDDER(S) (ITB)

For

**ENGINEERING, PROCUREMENT AND CONSTRUCTION
MANAGEMENT (EPCM) SERVICES FOR INSTALLATION OF
LPG AMINE ABSORBER SYSTEM IN PFCC UNIT AT MRPL,
MANGALURU.**

Tender No.: 3200000464



**ENGINEERING, PROCUREMENT AND CONSTRUCTION MANAGEMENT (EPCM) SERVICES FOR
INSTALLATION OF LPG AMINE ABSORBER SYSTEM IN PFCC UNIT AT MRPL, MANGALURU**

INSTRUCTION TO BIDDER(S) (ITB)

INDEX

<u>CLAUSE NO.</u>	<u>DESCRIPTION</u>
1.0	GENERAL
2.0	COST OF BIDDING
3.0	SITE VISIT
4.0	TENDER INSTRUCTIONS
5.0	CLARIFICATION REQUESTS BY BIDDER
6.0	CORRIGENDUM/ ADDENDUM/ CLARIFICATION
7.0	CONFIDENTIALITY OF BIDDING DOCUMENT
8.0	LANGUAGE OF BID
9.0	PREPARATION AND SUBMISSION OF BIDS
10.0	TENDERS INVITED THROUGH E-PROCUREMENT SYSTEM
11.0	TENDERS INVITED ON MANUAL MODE
12.0	PRICE / SCHEDULE OF RATES (SOR) / BILL OF QUANTITIES
13.0	BID CURRENCY
14.0	EARNEST MONEY DEPOSIT (EMD)
15.0	PRE-BID MEETING
16.0	LATE BIDS
17.0	MODIFICATION AND WITHDRAWAL OF BIDS(APPLICABLE FOR E-TENDERS ONLY)
18.0	BID OPENING
19.0	BID EVALUATION AND AWARD CRITERIA
20.0	REBATE
21.0	NOTIFICATION OF AWARD
22.0	UNSOLICITED POST TENDER MODIFICATIONS
23.0	CONTACTING MRPL
24.0	CANVASSING
25.0	COLLUSIVE BIDS
26.0	MULTIPLE/ALTERNATIVE BID
27.0	CARTEL FORMATION
28.0	CORRUPT AND FRAUDULENT PRACTICES
29.0	PUBLIC UTILITY SERVICE
30.0	INTEGRITY PACT
31.0	RAISING DISPUTES / COMPLAINTS
32.0	HOLIDAY LISTING POLICY
33.0	CONTRACT AGREEMENT



ENGINEERING, PROCUREMENT AND CONSTRUCTION MANAGEMENT (EPCM) SERVICES FOR INSTALLATION OF LPG AMINE ABSORBER SYSTEM IN PFCC UNIT AT MRPL, MANGALURU

INSTRUCTION TO BIDDER(S) (ITB)

1.0 GENERAL:

- 1.1 Mangalore Refinery and Petrochemicals Limited (MRPL), a subsidiary of Oil and Natural Gas Corporation Limited, is operating a 15.25 MMTPA fuels refinery at Mangalore. The Refinery complex is integrated to Aromatic Complex and designed to produce 900,000 TPA of Paraxylene.
- 1.2 The bidder is advised to read these instructions carefully and to ensure that his response complies fully with the requirements of the tender. Failure to provide the information and documents required by this Invitation to Bid may render the Bid to be unacceptable. Tender should be submitted in the prescribed form supplied by the company only.
- 1.3 The bidder shall download the complete set of tender document from the owner's website as per the index of the tender, fully read, understand & compile the same as per the various instructions contained herein and in "Instructions to Bidder".
- 1.4 Every bidder must submit bid strictly in accordance with the conditions and specifications prescribed by MRPL. Special conditions (if any) submitted along with the tender documents by the bidder will not be applicable to this Tender, in case they are in conflict with any of our terms and conditions.
- 1.5 Bidders to note that Physical/ Hard Copy of the Tender Documents shall not be issued from the office of Tender Inviting Authority. Any request in this regard shall not be entertained under any circumstances.

2.0 COST OF BIDDING:

- 2.1 The Bidder shall bear all costs associated with the preparation and submission of its bid and MRPL will in no case be responsible or liable for those costs, regardless of the conduct or outcome of the bidding process.

3.0 SITE VISIT :

- 3.1 Bidder is advised to visit and examine the site and its surrounding and shall familiarize himself of the existing facilities and environment and shall collect all other information which he may require for preparing and submitting the Tender and entering into the contract. Claims and objections due to ignorance of existing conditions or inadequacy of information will not be considered after submission of the Bid and during the contract period / after contract period. All costs for and associated with site visits shall be borne by the bidder.
- 3.2 The bidder and any of his personnel or authorised representatives will be granted permission by the OWNER to enter upon its premises and lands for the purpose of such inspection, but only upon the explicit condition that the bidder, its personnel or authorised representative shall be understood to have released and indemnified the OWNER and its personnel from and against all liability in respect thereof and will be responsible for personal injury (whether fatal or otherwise), loss of or damage to property and any other loss, damage, cost and expenses incurred as a result of such visit.

4.0 TENDER INSTRUCTIONS:

- 4.1 The Tender document comprises of following sections:-
 - Notice Inviting Tender.
 - Bid-Qualification Criteria/Bid Evaluation criteria.
 - Instruction to Bidder.
 - General conditions of Contract.
 - Formats of Credentials / EMD / Security Deposit, etc.
 - Integrity pact, etc.
 - BQC Compliance, Deviation statement, declaration, etc
 - Scope of work / Special Conditions of Contract,

- Price bid format.
 - Contract Workers Safety Policy.
- 4.2 The Tender Documents shall always be & remain the exclusive property of the Owner without any right with the Bidder to use them for any purpose except for submitting the tender in accordance with the provisions of these instructions by the prospective Bidders and for use by the successful Bidder with reference to the work. The Owner shall have no obligation to return to the Bidder the Tender Documents submitted by the Bidder.
- 4.3 The Tender shall be completely filled in all respects and shall be tendered together with requisite information & annexure. The Bidder is expected to examine the Tender Documents, including all instructions, specifications and drawings in the tendering document. Failure to furnish all the information required by the tendering documents or tender incomplete in particulars or submission of tender not substantially responsive to the tendering document in every respect shall result in rejection of the Tender.
- 4.4 It is hereby stipulated that the Tenderers shall not affect any corrections/ alterations/ modifications in the Tender Documents and various formats contained therein. Any correction/ alteration/ modification in the Tender Documents by the Bidder shall make their tender liable for rejection.
- 4.5 Originals of the documents related to the tender should be produced as and when asked for verification, and failure to produce such Original document(s) at specified date, time and place would mean rejection of tender for further evaluation.
- 4.6 When person signing the Tender / agreement is not the sole Proprietor of the company the original Power of Attorney or a Notary certified copy thereof authorizing such person to act and sign on behalf of the company must be enclosed.
- 4.7 Date format should be DD/MM/YYYY (Date/Month/Year).
- 4.8 Bidders should get clarified all the technical doubts and other points related to the tender before submitting the priced and un-priced offer.
- 4.9 MRPL reserves the right to accept or reject any or all tenders and at any stage of the tender evaluation process at the company's sole discretion and without assigning any reason thereof.
- 4.10 Any false/fake/incorrect information submitted by the bidder/contractor while submitting the bid will be liable for rejection of bid, action like Forfeiture of EMD, Cancellation of the Order, Forfeiture of Security deposit including Banning/Holiday listing of the Bidder's Company/ Contractor in all ONGC/MRPL establishments.
- 4.11 Any false/fake/incorrect information surfaced out after award of job would lead to action like Forfeiture of EMD, Cancellation of the Order, Forfeiture of Security deposit including Banning/Holiday listing of the Bidder's Company/ Contractor in all ONGC /MRPL establishments.
- 4.12 If the successful bidder, backs out during finalization of tender/after award of order, action will be initiated by MRPL as deemed fit.
- 4.13 The tender terms/ conditions as per SCC (Special conditions of the contract) Supercedes all similar terms prescribed under GCC/ Other Conditions of Contract (OCC).
- 4.14 MRPL reserves it right to seek the Originals if needs or inspect the documents at its premises for verification and return. In case, it is found that the bidder has attempted to mislead MRPL on any counts, MRPL may proceed with any action that is deemed fit.
- 4.15 "The item supplied / service provided shall be Environment friendly and Energy efficient".

5.0 CLARIFICATION REQUESTS BY BIDDER:

- 5.1 Although the details presented in this Tender document consisting of Conditions of Contract, Scope of Work, Technical Specifications and Drawings have been compiled with all reasonable care, it is the Bidder's responsibility to ensure that the information provided is adequate and clearly understood.
- 5.2 Bidder shall examine the Tender document thoroughly in all respect and if any conflict, discrepancy, error or omission is observed, Bidder may request clarification at any time up to one week prior to the tender closing date. Such clarification requests shall be directed as per the contact details mentioned in the NIT.
- 5.3 Any failure by Bidder to comply with the aforesaid requirement shall not excuse the Bidder, after subsequent award of contract, from performing the work in accordance with the agreement.

6.0 CORRIGENDUM/ ADDENDUM/ CLARIFICATION:

- 6.1 MRPL may, for any reason whether at his own initiative or in response to the clarification requested by the prospective bidder, issue amendment in the form of addendum/corrigendum/clarification during the Tender period and subsequent to receiving the Tenders. Any addendum / corrigendum / clarification thus issued shall become part of Tender document.
- 6.2 For addendum/corrigendum/clarification issued during the Tender period, Bidder shall consider the impact in his Tender. For addendum/corrigendum/clarification(s) issued subsequent to receiving the Tenders, Bidder shall follow the instructions issued along with addendum/corrigendum/clarification(s).
- 6.3 Such Addendum / Corrigendum/ Clarification(s) shall be uploaded on the MRPL website (<https://mrpl.co.in>) / Owner's e-tendering portal and it will not be published in newspaper. Prospective bidders should visit the above MRPL website / MRPL's e-procurement site from time to time to make note of corrigendum/addendum/clarification if any. MRPL is not responsible for non-receipt of any communication / information of addendum/corrigendum/clarification.
- 6.4 All such Addendum / Corrigendum / Clarification(s) issued shall form part of the Tender Documents.
- 6.5 It is incumbent on all the Bidders to view, download, understand and furnish Addendum / Corrigendum / Clarification(s) along with his/its/their tender. Any deviation/ clarification due to non-receipt of Addendum / Corrigendum / Clarification(s) at later stage should not be entertained. Any bid without copy of Addenda/ Corrigenda/ Clarification(s), if issued, as mark of its acceptance may not be accepted.

7.0 CONFIDENTIALITY OF BIDDING DOCUMENT:

- 7.1 All information disclosed to the Tenderers by way of the Tender Documents shall be considered confidential and any person/ Tenderer shall not part with possession of the Tender Documents or copy or disclose information thereof to any party, except as may be necessary for carrying out the work. It is being understood that the Tender Documents have been downloaded by the eligible Tenderer solely for the purpose of bidding. Where it is found that any Tenderer has violated and has disclosed sensitive and vital information impugning on the security of the installation/ national security, necessary action, as may be called for, may be taken against the Tenderer concerned in addition to his being liable to be black listed and/ or barred from participating in future bids.

8.0 LANGUAGE OF BID:

- 8.1 The Bid and all correspondence incidental to and concerning the Bid shall be in the English Language. For supporting documents and printed literature submitted in any other language, an equivalent English Translation shall also be submitted. Responsibility for correctness in translation shall lie with the Bidder. In case of any conflict, for the purpose of interpretation of the Bid, the English Translation shall govern.
- 8.2 In the event of submission of any document / certificate by the Bidder in a language other than English, the English translation of the same duly authenticated by Chamber of Commerce of Bidder's country shall be submitted by the Bidder.

9.0 PREPARATION AND SUBMISSION OF BIDS:

- 9.1 The offer must be complete in all respects, leaving no scope for ambiguity. Bidder is fully responsible for the bid submitted and no relief or consideration can be given for errors and omissions.
- 9.2 **Date & Time of submission:** Bid must be submitted by the due date and time mentioned in the notice Inviting Tender / Letter inviting Bid or any extension thereof as duly notified in writing on MRPL / e-tender website.
- 9.3 Bidder shall submit the offer in two parts:
Part I - Techno-Commercial (un-priced) bid and
Part II - Priced bid.
- 9.4 Price bid & technical bids if submitted together shall be summarily rejected.
- 9.5 **Part I - Techno-commercial bid (Unpriced Bid)** shall be submitted with all documents that are called **for in PDF format only**
- Bid Form as per **FORM-A** (FORM OF TENDER for Commercial Bid) & **FORM A1**(information about tenderer Concurrent Commitments of the Bidder)
 - Scanned copy of duly authenticated documents in support of meeting the Experience and Financial criteria as per **FORM-B1 & B2**.
 - Copy of EMD/Bid Security as per clause 14.0 below.
 - Power of attorney in favour of signatory (ies) of the bid.
 - Copy of Partnership Deed in case of Partnership Firm or Memorandum & Article of Association in case of Limited Company.
 - Compliance to Bid requirement as per **FORM-C** or in case of Deviation/ Exceptions (Bidder is requested not to stipulate any deviation), as per proposal **FORM-D**. (Sheet-1 for Commercial Section and Sheet-2 for Technical Section)
 - Check List duly filled in as per **FORM-E**.
 - Reply to Commercial Questionnaire as per **FORM-F**.
 - Details regarding PF as per **FORM-G**.
 - Declaration by Bidder regarding Black listing/ Holiday listing as per Performa **FORM-P**.
 - Declaration by the Bidder as per **FORM-J**.
 - Submission of Undertaking for non-engagement of child labour as per **FORM-K**
 - Bank details of Bidder as per **FORM-L**
 - Integrity Pact Agreement along with Affidavit, duly signed & Stamped as per **FORM-M1 & Affidavit as per FORM-M2**.
 - Letter of Waiver on Letter head of Bidder as per **FORM-N**
 - Technical offer and Engineering details, if any, required as per Bidding Document.
 - Blank copy (without price/ Percentage BOQ) of Price bid, indicating Quoted / Not Quoted duly signed and stamped.



ENGINEERING, PROCUREMENT AND CONSTRUCTION MANAGEMENT (EPCM) SERVICES FOR INSTALLATION OF LPG AMINE ABSORBER SYSTEM IN PFCC UNIT AT MRPL, MANGALURU

- Complete copy Tender document Signed & Stamped on each page in token of acceptance.
- Any other information required in the Bidding Documents or considered relevant by the Bidder.
- Signed & Stamped copy of Statement of Credentials –**Form R**.
- Declaration about Liquidation, Court receivership-**FORM-S**
- Signed & Stamped copy of Minimum Manpower to be deployed by the Consultant (**SCC Annexure III**).
- Declaration about any Current Litigation/ Arbitration, if any, in which bidder is involved.**(Form-Q)**
- Cancelled cheque of bidders.
- PAN card Copy.
- Signed Copy of MRPL Contract Workers Safety Policy (**Annexure –II to SCC**)
- Hard copy of following authenticated documents to be submitted along with EMD to the address provided:
 1. Integrity Pact
 2. Power of Attorney

Note: Bidders are required to serially number all the pages being appended by them as part of submission to the Technical bid. Such numbering shall include Covering letter, Technical specifications, Items list being offered, Drawings, Bid qualification proof, Testimonials, Certificates, Catalogues, Compliance or Deviation statements, etc as applicable to this Tender and create an Index Page with headings and corresponding page numbers. Declaration as per the format of 'Undertaking by Bidders' duly signed & stamped by the bidder in token of having read and understood all the tender requirements and accept all terms and conditions of the tender including all corrigendum / addendum / clarification issued, if any. In addition to this, all pages of the Tender documents issued by MRPL shall be signed on all pages and submitted/upload along with the Technical Bid / attachment in EPS system.

- 9.6 **Priced bid (Part II)** shall be submitted in the same format as mentioned/Included in the Tender document. Otherwise, offer will be liable for rejection.
- 9.7 No assumption, stipulation, deviations from terms and conditions or presumptions, etc. shall be made by the bidder while submitting the offer in the Price Part of the Tender. The liability of obtaining all necessary clarity with respect to the tender, its technical aspects and pricing shall be on the vendor. MRPL shall be under no obligation whatsoever to entertain any tender bid which is based on any assumption, stipulation, deviations from terms and conditions or presumptions, etc. and would have the option to reject such bid at their discretion.
- 10.0 **TENDERS INVITED THROUGH E-PROCUREMENT SYSTEM:**
- 10.1 For tenders invited through E-Procurement System, bids shall be submitted through **online (EPS) mode only** on the Owner's e-tendering portal for tenders invited through e-procurement mode.
- 10.2 Bidders to upload the Un-priced and Price part of their bids strictly in the Unpriced & Priced folders respectively at the designated place in the e-tender portal. Non Compliance to the same may lead to rejection of their offer.
- 10.3 **Bids submitted in any other form through Telex/ Fax/ Telegram/ E-mail/ Courier/ Registered Post/ manually shall not be accepted.**
- 10.4 However, documents which necessarily have to be submitted in originals like EMD and any other documents mentioned in the Tender Documents have to be submitted offline.



ENGINEERING, PROCUREMENT AND CONSTRUCTION MANAGEMENT (EPCM) SERVICES FOR INSTALLATION OF LPG AMINE ABSORBER SYSTEM IN PFCC UNIT AT MRPL, MANGALURU

The Owner shall not be responsible in any way for failure on the part of the Bidder to follow the instructions.

- 10.5 Bidders should avoid the last minute rush to the website for registration of user id and password, enabling of user id and mapping of Digital Signature, SI no, etc., since this exercise require activities from MRPL and EPS provider and needs time. In the event of failure in bidder's connectivity with MRPL/Service provider during the last few hours, bidder is likely to miss the deadline for bid submission. **Due date extension request due to above reasons may not be entertained.**
- 10.6 Bidders to note that the very act of using Digital Signature Certificate (DSC) for downloading the bids and uploading their offers shall be deemed to be a confirmation that they have read all pages of the bid document without any exception.
- 10.7 **E-Procurement System Instructions :**
- 10.7.1 Tender is invited on-line on the website www.tenderwizard.com/MRPL from **the firms** having Class IIB or above Digital Signature Certificate (DSC) (with Signing & Encryption Certificate) issued by any agency authorized by Controller of Certifying Authority (CCA), Govt. of India.
- 10.7.2 Offers received online on the e-procurement portal only will be considered for evaluation.
- 10.7.3 The server date and time as appearing on website www.tenderwizard.com/MRPL shall only be considered as cut-off time for receipt of tenders. Offers received by any other mode will not be considered.
- 10.7.4 Bidders are responsible for obtaining the digital certificates for participation / submission of bids at their cost.
- 10.7.5 The digital certificate shall be registered on the portal www.tenderwizard.com/MRPL and bidders shall upload the bid well in time.
- 10.7.6 Bidder shall download the bidding manual, system requirement and vendor registration manual and JRE setup for portal www.tenderwizard.com/MRPL to get acquainted with the procedures for submitting the online bids and load their Bids well within the time provided for bid submission to avoid last minute hassles
- 10.7.7 MRPL shall not be responsible for any delays occurred due to reasons whatsoever in receiving as well as on line submission of offers, including internet connectivity, document uploading/downloading issues etc.
- 10.7.8 Any corrigendum / amendment to the tender will be uploaded on e-Procurement site www.tenderwizard.com/MRPL and will not be published through other mode. Prospective bidders should visit the above MRPL e-Procurement site from time to time to make note of corrigendum / amendment if any.
- 10.7.9 In case of any queries regarding registration, bid submission procedure and system related, the bidder shall contact help desk of our e-procurement service provider M/s. ANTRES SYSTEM Ltd., contact person Mr. Dilip Ranganath, contact no. 0824-2882248. **Email:eps@mrpl.co.in.**
- 10.7.10 Support details as mentioned below;

Support Location	Name	Contact No.	Email ID
Mangalore	Mr.DilipRanganath	0824-2882248	eps@mrpl.co.in
Bangalore	Mr.Mohan Kumar	080-49352000	mohan@antaressystems.com
	Mr.PrabhuSwamy	080-49352000	prabhuswamy@antaressystems.com

11.0 TENDERS INVITED ON MANUAL MODE:

~~11.1 For tenders invited through Manual mode submission, Offer shall be submitted in two parts in two separate sealed covers:~~

~~Part-I Technical & Commercial (un-priced) bid and
Part-II Priced bid.~~

~~11.2 Both the sealed covers containing Part-I (Un priced Technical Bid) and Part-II (Priced Bid) shall be put in one single cover and submitted by duly super scribing Enquiry Number & Bid Closing date to the following address, before due date and time :~~

**Materials Department,
Mangalore Refinery and Petrochemicals Limited,
Kuthethoor, Katipalla, Mangalore 575 030.
Karnataka, India**

~~11.3 In case offer received without super scribing Tender Number it will be treated as unsolicited offer.~~

~~11.4 MRPL will not be responsible for any loss of postal delay.~~

12.0 PRICE / SCHEDULE OF RATES (SOR) / BILL OF QUANTITIES :

12.1 Unless otherwise agreed to in the terms of the Purchase Order, the price shall be firm and not subject to escalation for any reason whatsoever till the execution of entire Purchase order/Contract, even though it might be necessary for the Purchase order /Contract execution to take longer than the Completion period specified in the Purchase order/Contract.

12.2 The SOR shall be read in conjunction with all other sections of Tender document.

12.3 The price quoted by the Bidder shall be firm and fixed for the completion period of the tendered works, unless stated otherwise.

12.4 Rates / amount must be filled in 'Schedule of Rates / price bid' only. In any case, Bidder shall be presumed to have quoted against the tendered description of work and the same shall be binding on the Bidder.

12.5 Bidder shall quote for all the items of 'Schedule of Rates / price bid' after careful analysis of cost involved for the performance of the completed item(s) considering all parts of the Tender document. In case any activity though specifically not covered in description of item under 'Schedule of Rates / price bid' but is required to complete the work as per Scope of Work, Scope of Supply, Specifications, Standards, Drawings, General Conditions of Contract, Special Condition of Contract or any other part of Tender document, the item(s) quoted price will deemed to be inclusive of cost incurred for such activity.

12.6 All item(s) of work in the Bill of Quantities shall be carried out as per the specifications, and directions / instructions of the Engineer-in-charge and the rates are inclusive of labour, supervision, as well as preparatory, incidental, intermediate / auxiliary / ancillary or enabling works.

12.7 The rate shall include all expenditure incurred towards mobilisation and de-mobilisation. All prices shall be quoted in Indian Rupees unless otherwise instructed.

12.8 Bidder shall be considered only if the bidder has quoted for all the items of the 'Schedule of Rates / price bid' unless stated otherwise. Tenders which are received with some item(s) left blank / not quoted for all the items of the 'Schedule of Rates / price bid' shall be liable for rejection.

- 12.9 For supply items under the scope of the Contractor supply, the rates quoted by the Bidder shall be all inclusive for delivery of materials at site (F.O.R. destination basis). It shall include Basic Cost, all applicable taxes, duties & levies, inspection charge, transportation charges, transit insurance, auxiliary taxes, etc. as may be applicable. The consignee for despatch of materials shall be the Contractor. However, the Contractor/ Supplier shall be responsible for any incidental consequences arising out during the transit of materials up to destination (site).
- 12.10 Prices quoted by the Bidders shall be strictly in the given price bid format. Prices should not be clubbed with any of items in any way i.e. complete break up as suggested to be given after each item for the materials and works covered under the scope of contract, otherwise the bid may be considered as non-responsive.
- 12.11 Unless stated otherwise in the Tender Documents, the contract shall be for the complete supplies, services and composite works as described in the relative scope of supplies, services and composite works.
- 12.12 All Government circulars/ guidelines applicable on tender work would be enforced from time to time and it would be binding on the part of the Bidder/Contractor to abide by the same as per stipulations.
- 12.13 Price Bid shall not contain any conditions whatsoever. Any condition mentioned therein, Price bid shall not be considered for evaluation.
- 12.14 **Any incomplete bid in any of the above requirement shall be considered as non-responsive and shall be summarily rejected without any reference whatsoever to the Bidder.**
- 12.15 **Rates to be quoted in Figures & words:**
The price quoted by the Bidder shall be checked for arithmetic correction, if any, based on rate and amount filled by the Bidder in the standard SOR / Price Bid format. If some discrepancies are found between the rate / amount given in words and figures, the total amount shall be corrected as per the following procedure, which shall be binding upon the Bidder:
- 12.15.1 Prices shall be written both in Words and Figures. In the event of discrepancy between the price in figures and words, the amount entered in words would be taken into consideration for evaluation and finalization of the order.
- 12.15.2 When the rate quoted by the Bidder in figures and words tallies but the amount is incorrect, the rate quoted by the Bidder shall be taken as correct and amount reworked.
- 12.15.3 When there is difference between the rate in figures and words, the rate which corresponds to the amount worked out by the Bidder shall be taken as correct.
- 12.15.4 When it is not possible to ascertain the correct rate, in the manner prescribed above the rate as quoted in words shall be adopted and amount reworked.
- 12.15.5 When Bidder has quoted only in figures and the amount written against the particular item does not correspond to the rate written in figures, then the higher of the rates i.e. rate worked out by dividing the amount with quantity and quoted rate in figures shall be adopted for evaluation purposes and in the event such a Tender is determined lowest Tender, then lower of the rates mentioned shall be considered to award of the works.
- 12.15.6 When Bidder has quoted rates in figures and words but has not calculated the amount and the total contract price, such Tenders shall be rejected forthwith without consulting the Bidder.
- 12.16 Bidder shall bear, within the quoted rates, income tax liability of both corporate and Personnel as applicable in respect of their personnel and their sub contractor's personnel, arising out of this contract. Bidder shall also bear, within the quoted rates, the Corporate Tax, as applicable, on the income arising out of this contract.



ENGINEERING, PROCUREMENT AND CONSTRUCTION MANAGEMENT (EPCM) SERVICES FOR INSTALLATION OF LPG AMINE ABSORBER SYSTEM IN PFCC UNIT AT MRPL, MANGALURU

12.17 The rates quoted by the bidder shall be inclusive of all duties, taxes and levies etc, Central or State or Local bodies, etc. except GST.

12.18 The rates stated in the Schedule of Rates shall not be subject to escalation on any account whatsoever.

13.0 BID CURRENCY:

13.1 Bidders should quote firm prices in Indian rupee only unless otherwise specified else where in this tender. Prices quoted in any other currency shall not be considered.

13.2 For Global tenders, Foreign Bidders may quote prices for materials and services to be imported into India either in Indian Rupees or in Foreign Currency. For the purpose of this clause and any other relevant provisions in these documents, Foreign Currency (FC) shall mean and be limited to US DOLLARS, GREAT BRITAIN POUND, EURO and JAPANESE YEN.

13.3 Bidders shall quote the price for materials and services to be procured from India and for expenses to be incurred in India only in Indian Rupees.

13.4 For evaluation purposes, the bid price shall be converted to Indian Rupees by converting the Foreign Currency into Indian Rupees at the RBI Exchange Rate prevailing on the day of opening of the price bid.

14.0 EARNEST MONEY DEPOSIT (EMD):

14.1 EMD shall be submitted by way of Demand Draft in favour of M/s Mangalore Refinery and Petrochemicals Limited, and payable at Mangalore. Bank Guarantee in place of demand draft shall also be accepted as per format enclosed. **BG shall be valid for 180 days from the date of bid submission. Offer submitted without requisite / insufficient EMD will be summarily rejected without assigning any reason.**

The irrevocable Bank Guarantee (BG) in the prescribed format if submitted against Earnest Money Deposit shall be subject to verification from the issuing Bank, the email ID of bank for the same must be incorporated in the BG.

The BG issued by the issuing Bank on behalf of Bidder/Contractor/Supplier in favour of "Mangalore Refinery and Petrochemicals Limited" shall be in paper form and also be made available under the "Structured Financial Messaging System" (SFMS).

A separate advice of the BG will invariably be sent by the issuing bank to the beneficiary's Bank through SFMS and SFMS transmission message reference number (currently 32 digits code) is to be sent along with BG directly to MRPL through speed post/regd. Post.

The details of beneficiary for issue of BG under SFMS platform is furnished below:

Name of Beneficiary: Mangalore Refinery and Petrochemicals Limited

Beneficiary Bank, Branch and address: Union Bank of India (Erstwhile Corporation Bank), MRPL Project Site, Kuthethoor Post Mangaluru 575030, Karnataka

IFSC code: CORP0000592

SWIFT Code: CORPINBB

MICR Code: 575017015

Any bank guarantee submitted in physical mode which cannot be verifiable through SFMS will not be accepted under any circumstances.

- 14.2 Earnest Money Deposit (EMD) of value mentioned above should be sent in a separate cover to the following address;
Project Department,
II Floor, Nethravathi Building,
Mangalore Refinery & Petrochemicals Limited,
Kuthethoor P.O., Via Katipalla,
Mangaluru- 575 030.
- Super scribing tender number and bid submission date on the envelope. It should reach positively on or before the bid due date and time. Otherwise, the bid will be liable for rejection.
- 14.3 In case of bids invited through EPS, Bidders are also advised to scan the Draft/BG and upload in EPS along with the technical bid document.
- 14.4 Incomplete tender/ tenders **without requisite / insufficient EMD** will be rejected. The Company reserves the right to reject a tender or all the tenders without assigning any reason whatsoever.
- 14.5 EMD may be paid in one of the following forms in a separate sealed cover.
- Demand drafts drawn on Scheduled Bank in favour of Mangalore Refinery and Petrochemicals Ltd, Mangalore.
 - Bank Guarantee in prescribed format (enclosed) which is enclosed, executed by scheduled / Nationalised Bank and valid for a period of 180 days.
 - EMD to be sent to the concerned officer before due date/ time.
- 14.6 Company will not be responsible for loss or late / non receipt of EMD. No interest shall be payable on Earnest Money Deposit. Late receipt of EMD will be summarily rejected. No Cheques will be accepted towards EMD.
- 14.7 Tender will be summarily rejected under following circumstances
- EMD submitted in form of cheque.
 - The name of tender mentioned in the BG is different from the tender for which bids have been invited.
 - The firm on whose behalf the BG has been furnished is different from the bidder
 - The EMD is not of prescribed/requisite value.
 - The validity of the BG is less than the stipulated period.
- l) Earnest Money is liable to be forfeited if tenderer.
- Withdraws or modifies offer in full or part during the validity period.
 - Failure of the bidder to honor their offer.
 - Non acceptance of Purchase / Work Order placed by MRPL.
 - Does not Confirm of acceptance of order within the stipulated time after placement of order.
 - Inability to perform satisfactorily after receipt of order in case of successful bidder.
 - If document(s)/certificate(s) submitted along with the bid are found false/fake, fabricated, incorrect information.
 - The name of the tender mentioned in the BG is different from the tender for which bids have been invited.
 - The firm on whose behalf the BG has been furnished is different from the bidder.
- 14.8 The following are exempted from payment of EMD.
- The unit is registered with NSIC for the item tendered.

- ii. In- line with the Government Directives, Small Scale Industrial Units registered with National Small scale Industries Corporation (NSIC) under the single point registration scheme shall be exempted from submitting EMD for items registered with NSIC and upto the monetary limit specified in the registration certificate.

MSE (Micro &. Small Enterprises) registered with DIC.

MSEs who are having Udyog Aadhar Memorandum.

PSU'S / Startups are exempted from payment of EMD.

14.9 Refund of EMD :

- i. If the successful tenderer commences supplies / work and also lodges the security deposit in the manner prescribed and within the period specified, MRPL shall return to him Earnest Money Deposit, paid by him without any interest thereon.
- ii. Earnest Money Deposit will be refunded to all unsuccessful tenderers after finalization of the Tender.

15.0 PRE-BID MEETING :

- 15.1 Pre-bid meeting shall be held as per time & at the venue specified in the Tender Invitation. In case pre-bid meeting information is not available in the Tender Invitation & the Owner decides to have a pre-bid meeting to clarify any issues, necessary intimation with adequate notice shall be posted on e-tendering portal.
- 15.2 Bidders can submit their queries through the e-tendering portal/e-mail one day prior to the due date of Pre-bid meeting. The queries shall be replied during the pre-bid meeting or the Owner will respond through the e-tendering portal to any request for clarification received by the deadline for submission of queries.
- 15.3 Brief summary of the queries received through e-tendering portal, queries raised by the attending tenderers during pre-bid meeting and the clarifications given by the Owner respect thereof, as well as any further information which the Owner choose to furnish to the tenderers, shall be posted on e-tendering portal in the form of Minutes of the Meeting or Addendum, which shall form a part of the Tender Documents, unless otherwise specified.
- 15.4 The tenderer or their representatives with necessary authorisation letter can be present during the Pre bid conference, if any.
- 15.5 If pre-bid meeting information is not available in the e-tender notice then the same shall not be held.

16.0 LATE BIDS:

- 16.1 Any bid received by MRPL after the deadline for submission of the bids (including any extension(s) hereof) will be declared "Late" and shall be rejected.
- 16.2 The "Late Bid" shall be returned unopened to the bidder in due course in case of Manual Tenders.

17.0 MODIFICATION AND WITHDRAWAL OF BIDS (APPLICABLE FOR E-TENDERS ONLY):

- 17.1 The Bidder may modify or withdraw its bid after the bid's submission, provided that the modification or withdrawal is uploaded on e-tender website prior to the deadline prescribed for submission of bids.

18.0 BID OPENING:

18.1 UN-PRICED (TECHNO-COMMERCIAL) BID OPENING:

- 18.1.1 Techno-Commercial (Un-priced) Part (Part-I) will be opened on the scheduled date and time.

- 18.1.2 For E-Tenders, Bidders can also witness bid opening by logging on to the E-Tendering website through their system using their valid digital signature/certificate.
- 18.1.3 The bidder or their representative with necessary authorization letter can be present during the technical bid opening in case of Manual tender.
- 18.1.4 During the opening of Un-priced Part (Part-I), only the names of agencies who have quoted and furnished EMD shall be made public.
- 18.1.5 **Clarification of Bids:** MRPL, if necessary, will obtain clarifications on the bid by requesting for such information / clarifications from any or all bidders, either in writing or through personal contact. All responses shall be in writing, and no change in the price or substance of the bid shall be permitted unless specifically sought by MRPL.

18.2 **PRICE BID OPENING:**

- 18.2.1 Price part of only those bidders, whose bids are considered techno-commercially acceptable, shall be opened. Bidders selected for opening of their price bids shall be informed about the date of price bid opening.
- 18.2.2 The Price Bid opening shall be done of e-tender portal and Bidders can also witness bid opening by logging on to the E-Tendering website through their system using their valid digital signature/certificate.
- 18.2.3 In case of manual tenders, bidders may depute their authorised representative during the price bid opening with necessary authorisation letter.
- 18.2.4 Any unsolicited reduction in price offered by a bidder within the bid validity by way of discount or revised prices, subsequent to the bid due date, shall not be taken into account for comparison. However, such reduction in price shall be taken into account for ordering if such bidder happens to be recommended as per the originally quoted prices.
- 18.2.5 In the event of any unsolicited price increase sought by any bidder, subsequent to the bid due date, the bid of such a bidder shall be rejected, in case the bidder does not agree to withdraw the price increase. However, in case the unsolicited price increase is known only after price bid opening and the bidder's comparative ranking changes by withdrawal of the price increase, the Bidder shall not be allowed to withdraw the price increase and the bid shall be rejected outright. But, if such a bidder is lowest with or without the price increase, the order shall not be placed with price increase and if the bidder does not agree, the enquiry shall be refloated.
- 18.2.6 Wherever, decision is taken to reject a bid, EMD, if submitted, by the Bidder, shall also be forfeited and action as deemed fit.

19.0 **BID EVALUATION AND AWARD CRITERIA:**

19.1 **COMPLIANCE TO BID REQUIREMENT**

Bidders are requested to submit zero deviation bid, strictly as per terms and conditions of the Bidding Document. Bidder is required to confirm the same in the proforma provided in the Bidding Document. Stipulation or any deviation may render the bid liable for rejection. MRPL/ Owner expect the Bidder to comply with the requirements of the Bidding Document without any deviation and submit substantially responsive bid. MRPL/ Owner reserves the right to proceed with the evaluation if adequate nos. of techno commercially responsive bids have been received without raising any CQ/TQ.

Therefore, it is expected that bidders submits total compliance bid.

The deviation, if unavoidable, should be furnished as per FORM-D attached. Exception/ Deviations submitted elsewhere in the offer shall not be considered.

- 19.2 The Owner reserves the right to consider/ evaluate only substantially responsive tenders. A substantially responsive tender is one, which, in the opinion of the Owner (which shall be final and binding on the Tenderer(s)), substantially conforms to all the terms, conditions, specifications and requirements of the Tender Document without material deviations or reservations in respect of any of the following:
- Scope, Quality or Performance of the work;
 - The Owner's rights or the Tenderer's obligations under the contract as per the tender documentation;
 - Such deviations the correction of which would affect the competitive position of other tenderers, who have submitted substantially responsive bids;
 - Any tender unaccompanied by the Earnest Money in a form which is not acceptable as per the Tender Documents, or falling short of the requirement of the Tender Document, shall be liable for rejection.
 - MRPL reserves the right to use in-house information for assessment of capability of bidder and their performance on jobs completed / in progress for evaluation purpose.
 - Directives issued by Govt. of India from time to time shall be given due consideration during bid evaluation.
- 19.3 **Expressions like "can offer if required/ will be submitted later/ will be taken up during detailed engineering after order is placed/ noted etc." will be construed as "TOTAL NON-COMPLIANCE" and the Bid shall be deemed "NON-RESPONSIVE AND INCOMPLETE" and may be summarily REJECTED.**
- 19.4 Prior to detailed evaluation of bids, the Owner will determine whether each bid is substantially responsive to the requirement of bidding documents. If the bid is not substantially responsive to the requirements of the Tender Documents, it will be rejected by the Owner, and may not subsequently be made responsive by the Bidder having corrected or withdrawn the non-conforming deviation or reservation.
- 19.5 The requirements of specifications shall be approximately studied for compliance on each of the points. The Bidder may explain clearly his stand on the specifications not complied with. However bids in compliance to each point would be deemed "Responsive Bid".
- 19.6 Bids which do not cover the complete scope of work will be treated as incomplete and shall be rejected.
- 19.7 Bid stipulating completion period/delivery schedule beyond that specified may not be considered.
- 19.8 Substantially responsive bids shall be evaluated by the Owner to ascertain the relative position of the best evaluated bid in the interest of the Owner, for the total of the complete supplies and services covered by the Tender Documents including Technical Specifications and as set out in the Price Schedule.
- 19.9 The evaluation of bids shall be done on the basis of total prices quoted for the complete scope of work and Supply, Services, Composite Works and conditions elsewhere as specified in the tender.
- 19.10 The Prices quoted by Bidders in Price bid format FORM SP-0 shall be considered for the purpose of evaluation along with the GST quoted and commercial loading if any .
- 20.0 REBATE:**
- 20.1 No suo-moto reduction in price(s) by bidders is permissible after opening of the bid. If any Bidder unilaterally reduces the price(s) quoted by him in his bid after opening of bids, such reduction shall not be considered for comparison of prices but shall be binding on the Bidder if he happens to be selected for award of work. Conditional discount, if offered, shall not be considered for evaluation.

21.0 NOTIFICATION OF AWARD :

- 21.1 The lowest evaluated bid shall be accepted by owner for award. The Bidder, whose bid is accepted, selected for award of contract by Owner shall be issued Order/Letter/Fax of Acceptance (LOA/FOA) prior to expiry of bid validity. Bidder shall acknowledge the receipt.
- 21.2 MRPL shall not be obliged to furnish any information / clarification / explanation to the unsuccessful Bidders as regards non-acceptance of their bids. Except for refund of EMD to unsuccessful Bidders, MRPL shall correspond only with the successful bidder.

22.0 UNSOLICITED POST TENDER MODIFICATIONS:

- 22.1 Bidders are advised to quote as per terms and conditions of the Bidding Document and not to stipulate deviations/ exceptions. Once quoted, the Bidder shall not make any subsequent price changes, whether resulting or arising out of any technical/ commercial clarifications and details sought on any deviations, exceptions or stipulations mentioned in the bid unless any amendment to Bidding Document is issued by MRPL/Owner. Similarly, no revision in quoted price shall be allowed should the deviations stipulated by him are not accepted by MRPL/OWNER and are required to be withdrawn by him in favour of stipulation of the Bidding Document. Any unsolicited proposed price change is likely to render the bid liable for rejection.

23.0 CONTACTING MRPL :

- 23.1 No bidder shall contact the OWNER on any matter relating to its bid from the time of bid opening till the time Contract is awarded, unless requested to do in writing. Any effort by a bidder to influence the OWNER in the Owner's decisions in respect of bid evaluation or Contract award will result in the rejection of that bidder's bid and action as deemed fit shall be initiated against the bidder.

24.0 CANVASSING :

- 24.1 Canvassing in connection with tenders is strictly prohibited and the Tenders submitted by the Tenderers who resort to canvassing shall be liable to rejection.
- 24.2 Subject to the provisions concerning clarification of Bids, no Bidder shall contact the Owner on any matter relating to its bid from the time of the bid opening up to the time that the contract is awarded.
- 24.3 Any effort by the Bidder or Bidder's representative however described to influence the Owner in any way concerning scrutiny, consideration, evaluation of the Bid(s) or decision concerning award of contract shall entail rejection of Bid and action against the bidder as deemed fit.
- 24.4 The Owner will deal with the Bidder on a principal bases, without involvement in any manner in India or abroad of any agent or consultant or associate or other person howsoever described.

25.0 COLLUSIVE BIDS:

- 25.1 In case it appears to the owner, after examining the tenders received, that any 2 (two) or more tenders are collusive or otherwise manipulated to the disadvantage of the owner and against the spirit of ethical competition, the owner reserves the right to summarily reject such tenders. It shall not be incumbent on the owner to prove any collusion or other malpractice in this regard.

26.0 MULTIPLE/ALTERNATIVE BID :

- 26.1 A bidder (i.e., the bidding entity) shall, on no account submit more than one bid either directly (as a single bidder or as a member of consortium) or indirectly (as a sub-contractor) failing which following actions shall be initiated:

- 26.2 All bids submitted by such bidder (say 'A') directly or indirectly, shall stand rejected and EMD, if any, in case of direct bid submitted by bidder "A" shall be forfeited.
- 26.3 If another bidder (say 'B') has proposed bidder 'A' as a sub-contractor then bidder 'B's bid shall also be rejected. However, in case the bidder 'B' has also proposed an alternative sub-contractor who is other than the bidder 'A', then bidder 'B's bid shall be evaluated with the proposed alternative sub-contractor only. Hence, every bidder shall ensure in his own interest that his proposed sub-contractor is not submitting alternative/multiple bids.

27.0 CARTEL FORMATION :

- 27.1 In case any Bidder is found to be involved in cartel formation, his bid will not be considered for evaluation / placement of Order. Such bidder will also be banned from bidding in future.

28.0 CORRUPT AND FRAUDULENT PRACTICES:

- 28.1 Bidders are required to furnish the complete and correct information/ documents required for evaluation of their bids. If the information/ documents forming basis of evaluation is found to be false/ fake/ forged, the same shall be considered adequate ground for rejection of the bids and forfeiture of earnest money deposit.
- 28.2 OWNER requires that the CONTRACTOR observes the highest standard of ethics during the execution of Contract. In pursuance of this policy, OWNER defines, for the purposes of this provision, the terms set forth below as follows:
- "Corrupt Practice" means the offering, giving, receiving, or soliciting of anything of value to influence the action of public official in contract execution; and
 - "Fraudulent Practice" means a misrepresentation of facts in order to influence the execution of a Contract to the detriment of OWNER, and includes collusive practice among bidders (prior to or after bid submission) designed to establish bid prices at artificial non-competitive levels and to deprive OWNER of the benefits of free and open competition.
 - "False/Fake" means to make or construct falsely. "Faked alibi" is a made, manufactured, or false alibi. Something that is not what it purports to be; counterfeit, an imposter.
 - "Forgery" means the false making or the material altering of a document with the intent to defraud. A signature of a person that is made without the person's consent and without the person otherwise authorizing it. A person is guilty of forgery if, with the purpose to defraud or injure anyone or with knowledge that he is facilitating a fraud or injury to be perpetrated by anyone, the actor;
 - alters any writing of another without his authority
 - makes, completes, authenticates, executes, issues or transfers any writing, so that it purports to be the act of another who did not authorize that act or to have been executed at a time or place or in a numbered sequence other than was in fact the case, or to, be a copy of an original when no such original exists.Utters any writing which he knows to be false in a manner specified in (i) & (ii) above.
- 28.3 OWNER may terminate the Contract if it discovers subsequently that the Contractor had engaged in Corrupt Practices or Fraudulent Practices in competing for the Contract.
- 28.4 In case, the information/ document furnished by the Contractor forming basis of evaluation of its Bid is found to be false / fake/ forged after the award of the Contract, OWNER shall have the right to terminate the Contract and get the remaining Works executed by a third party at the risk & Cost of the Contractor and without any prejudice to other rights available to OWNER under the Contract such as forfeiture of the Contract Performance Bank Guarantee, withholding of payment etc.

28.5 In case, this issue of submission of false/fake documents comes to the notice after execution of the Works, OWNER shall have full right to forfeit any amount due to the Contractor along with forfeiture of the Contract Performance Bank Guarantee furnished by the Contractor. Further, any Contractor which is found guilty of any Corrupt or Fraudulent Practice or submission of false/fake /forged documents, shall be put on the blacklist / negative / holiday list of OWNER debaring them from future business with OWNER.

29.0 PUBLIC UTILITY SERVICE :

29.1 The Bidder / Contractor shall take on record that MRPL has been declared as a Public Utility Service under Industrial Dispute Act 1947 and Essential Services Maintenance Act 1994 and various other provisions hereby undertake on their behalf and on behalf of the employees under their roll that they refrain from indulging in any activity(ies) which would hamper Industrial peace in MRPL and also would extend their Assistance and support to MRPL to comply with the requirements within mentioned statutory requirement / declaration.

30.0 INTEGRITY PACT ALONG WITH AFFIDAVIT : (Applicable)

30.1 Bidders are required to sign and stamp the Integrity Pact (IP) along with Affidavit, as per the proforma enclosed in Proposal Forms **(FORM M1 & FORM M2)**. Proforma of Integrity Pact along with Affidavit shall be submitted in original by the Bidder along with their Bid (Part-I: Techno-Commercial Bid), duly signed in all the pages by the same signatory who is authorized to sign the Bid. Bidder's failure to submit the Integrity Pact duly signed shall result in the Bid not being considered for further evaluation.

30.2 Bidders shall also be required to furnish an Affidavit confirming that he is not involved in any case of transgression in terms of Integrity Pact as per the document provided as per Proposal Forms **(FORM M1 & FORM M2)**. Non Submission of Integrity Pact and Affidavit shall lead to not considering their bid for further evaluation.

31.0 RAISING DISPUTES/COMPLAINTS. (Applicable for all tenders where Integrity Pact is applicable.)

31.1 MRPL has appointed independent external monitors (IEMs). Bidders may raise disputes/complaints, if any, with the nominated Independent External Monitors (IEM). The name, emails & Phone no of the present IEMs are as given below:

SI No	IEMs	E-mail ID	Mobile / Phone
1	Shri. M N Krishnamurthy, IPS (Retd.)	krishnamurthymn19@gmail.com	9591110000 080-25427282
2	Shri S Ravi, IRS (Retd.)	sudhaandravi@gmail.com	9444143642 044 -24792558

31.2 Curriculum Vitae of Independent External Monitors (IEMs) are placed permanently on the home page of MRPL's website www.mrpl.co.in –Tenders.

31.3 The bidders may raise disputes / complaints, if any, either with the designated Competent Purchase Authority (CPA) related to the Tender or with the concerned Director of MRPL or directly with the IEMs c/o CVO, MRPL, Kuthethoor via Katipalla, Mangalore 575030.

31.4 Notes:

- (i) IEMs would not consider any representation received on the basis of oral submission made by the representing bidder unless additional documents or clarifications have specifically been sought by IEMs from such representing bidders.
- (ii) IEMs would consider only those representations on post contract issues wherein there is an alleged violation of provisions of IP.

32.0 HOLIDAY LISTING POLICY:

- 32.1 The Guidelines and procedures for Holiday Listing are available in MRPL website as Holiday Listing Policy and shall be applicable in the context of all tenders and consequently all Orders / Contracts / Purchase Orders. This can be accessed at URL www.mrpl.co.in refer to Tenders - Holiday Listing Policy.
- 32.2 Agencies participating in tenders are deemed to have read, accepted and agreed for the Holiday Listing Policy of MRPL and shall not seek any damages/compensation from MRPL on account of the Holiday Listing of business with the Agency.
- 32.3 **DECLARATION:** Any party or its associated company if had been in the holiday list / black-listed/ banned by any Central / State Government agencies or any Central / State PSU company or any Regulatory Institution/Authority and such name appears in the list of the above mentioned central / state Government agencies or central / state PSUs or any Regulatory Institution/Authority as on date is disqualified and would not be considered.

An affidavit to this effect/ or an affidavit that the vendor is not holiday listed / black listed / banned by above mentioned Agencies is required to be produced, if called for by MRPL, in the event of award of work order.

33.0 CONTRACT AGREEMENT:

The CONTRACTOR shall execute a formal contract with OWNER within 28 days from the date of issue of Letter of Acceptance, on a non-judicial stamp paper of ₹ 200/- value. The cost of non-judicial stamp paper shall be borne by the CONTRACTOR. Contract documents for agreement shall be prepared after the acceptance of bid. Until the final contract documents are prepared and executed, this Bidding Document together with the annexed documents, modifications, deletions agreed upon by the OWNER and bidder's acceptance thereof shall constitute a binding contract between the successful Bidder and the OWNER based on terms contained in the aforesaid documents and the finally submitted and accepted prices.

The Contract document shall consist of the following:

- a) Form of Contract on non-judicial stamp paper
- b) Original Bidding Document.
- c) Amendment to Bidding Document issued, if any.
- d) Fax/ Letter of Acceptance.
- e) Detailed Letter of Award (DLOA) along with enclosures.



PROPOSAL FORMS

TABLE OF CONTENTS

S. NO.	DESCRIPTION
1.	FORM OF BID - (FORM A)
2.	INFORMATION ABOUT TENDERER -(FORM -A1)
3.	PROFORMA OF BANK GUARANTEE IN LIEU OF EARNEST MONEY DEPOSIT (FORM-A2)
4.	FORMAT FOR SPECIFIC WORK MEETING THE EXPERIENCE CRITERIA (FORM B1 & B2)
5.	COMPLIANCE TO BID REQUIREMENT (FORM-C)
6.	EXCEPTIONS AND DEVIATIONS (FORM-D)
7.	CHECK LIST FOR SUBMISSION OF BID (FORM-E)
8.	COMMERCIAL QUESTIONNAIRE (FORM -F)
9.	DETAILS OF P.F. REGISTRATION (FORM-G)
10.	BIDDER'S QUERIES (TECHNICAL) (FORM H)
11.	BIDDER'S QUERIES (COMMERCIAL) (FORM-I)
12.	DECLARATION BY THE BIDDER (FORM-J)
13.	UNDERTAKING FOR NON-ENGAGEMENT OF CHILD LABOUR (FORM-K)
14.	FORMAT FOR BANK DETAILS OF BIDDERS (FORM-L)
15.	FORMAT FOR INTEGRITY PACT ALONG WITH AFFIDAVIT (FORM-M1 & M2)
16.	FORMAT OF LETTER OF WAIVER (FORM -N)
17.	PROFORMA OF DECLARATION OF BLACK LISTING/HOLIDAY LISTING (FORM P)
18.	DECLARATION FOR ARBITRATION/LITIGATION (FORM- Q)
19.	STATEMENT OF CREDENTIALS (FORM-R)
20.	DECLARATION FOR LIQUIDATION/COURT RECEIVERSHIP (FORM -S)
21.	UNDERTAKING BY THE BIDDERS



**ENGINEERING, PROCUREMENT AND CONSTRUCTION MANAGEMENT (EPCM) SERVICES FOR
INSTALLATION OF LPG AMINE ABSORBER SYSTEM IN PFCC UNIT AT MRPL, MANGALURU**

FORM-A

FORM OF BID

(TO BE GIVEN ON BIDDER'S LETTER HEAD)

FORM OF TENDER

(To be filled up by the Tenderer)

For Commercial Bid

Serial No.

Date:

From

To

Mangalore Refinery and Petrochemicals Limited
Mangalore

Tender No. _____

Dear Sirs,

Having examined the Tender Documents consisting of the Tender Notice, General Instructions to Tenderers, General Conditions of Contract, Special Instructions to Tenderers, Special conditions of Contract, Specifications, Plans (Exhibits _____ to _____), Drawings (Exhibits _____ to _____) Time Schedule, Form of Contract, Form of Schedule of rates, and Addendum (a) to the Tender Documents, and having understood the provisions of the said Tender Documents and having thoroughly studied the requirements of Mangalore Refinery and Petrochemicals Limited, relative to the work tendered for in connection with the _____ (Name of the Refinery/Project) and having conducted a thorough study of the job site(s) involved, the site conditions, soil conditions, the climatic conditions, labour, power, water, material and equipment availability, the transport and communication facilities, the availability and suitability of borrow areas, the availability of land for right of way and temporary office accommodation and quarters and all other facilities and things whatsoever necessary for or relative to the formulation of the tender of the performance of work, I/we hereby submit my/our tender offer for the performance of proposed work in accordance with the terms and conditions and within the time mentioned in the Tender Documents.

In consideration of the sum of Rupee 1/- (Rupee one) only paid to me/us by Mangalore Refinery and Petrochemicals Limited, by adjustment in the price of Tender Documents, I We further undertake to keep my/our this tender offer open for a period of not less than 4 (four) months from the schedule date of opening of Tenders as specified in the General Instructions to Tenderer forming part of the Tender Documents:

I/ We hereby further state that I/We/None of us (in the case of partnership firm) and none of our Directors (in the case of a Company) was/were employed as Directors of Mangalore Refinery and Petrochemicals Limited, during the period of 2(two) years immediately preceding the date hereof OR I/We hereby declare that I/Shri _____ one of our partners (in case of partnership firm/Directors in the case of a company) was employed as a Director in Mangalore Refinery and Petrochemicals Limited, during the period of 2 (two) years immediately preceding the date hereof and that I/Shri _____ have/has obtained previous permission of Mangalore Refinery and Petrochemicals Limited, to make this tender .



**ENGINEERING, PROCUREMENT AND CONSTRUCTION MANAGEMENT (EPCM) SERVICES FOR
INSTALLATION OF LPG AMINE ABSORBER SYSTEM IN PFCC UNIT AT MRPL, MANGALURU**

I/We have annexed to this Bid the following documents:

- i. Schedule or Rates in the prescribed form.
- ii. Original Power of Attorney or other proof of authority of the person who has signed the Tender OR copy of Power of Attorney attested by a Gazetted Officer or a Notary Public in proof of authority of the person who has signed the Tender.
- iii. Original Income-tax clearance certificate OR copy of Income-Tax Clearance certificate duly attested by Gazetted Officer/Notary Public.
- iv. Information regarding tenderer in the form annexed to the Form of Tender.
- v. Information regarding experience of the tenderer in the performance of work of a comparable nature in the form annexed to the Form of Tender.
- vi. Information regarding construction organization and equipment in the form annexed to the Form of Tender.
- vii. Solvency Certificate from a Nationalized/Scheduled bank.
- viii. Set of Tender Documents, as issued duly signed.
- ix. Additional Documents as listed below.

I/We hereby undertake that the statements made herein/information given in the Annexures referred to above are true in all respects and that in the event of any such statement or information being found to be incorrect in any particular, the same may be construed to be a misrepresentation entitling Mangalore Refinery and Petrochemicals Limited, to avoid any resultant contract.

I/We further undertake as and when called upon by Mangalore Refinery and Petrochemicals Limited to produce, for its inspection, original(s) of the document(s) of which copies have been annexed hereto.

I/We confirm having deposited earnest Money of Rs._____ (Rupees_____) as detailed hereunder (Strike off whichever is not applicable).

(Signature(s) of the Tenderer(s))

Name & Designation of Authorized person
Singing the Tender on behalf of The Tenderer(s):
Full Name and address of the Bidder(s):

Witness:

Signature

Name:

Occupation:

Name & Designation of Authorized person
Singing the Tender on behalf of The Tenderer(s):
Full Name and address of the Bidder(s):

Witness:

Signature

Name:

Occupation:



**ENGINEERING, PROCUREMENT AND CONSTRUCTION MANAGEMENT (EPCM) SERVICES FOR
INSTALLATION OF LPG AMINE ABSORBER SYSTEM IN PFCC UNIT AT MRPL, MANGALURU**

FORM OF TENDER

(To be filled up by the Tenderer)

For Price Bid

Serial No.

Date:

From

To

Mangalore Refinery and Petrochemicals Limited
Mangalore

Tender No. _____

Having examined the Tender Documents consisting of the Notice inviting Tender, General Instruction of Tenderer, General Conditions of Contract, Special Instructions to Tenderers, Special Conditions of Contract, specifications, plans, drawings, time-schedule, form of Contract, form of tender, form of Schedule of Rates and Addendum (s) to Bidding Document having understood the provisions of the said Tender Documents and having thoroughly studied the requirements of Mangalore Refinery And Petrochemicals Ltd., relating to the work tendered for in connection with the construction of (Name of Refinery/ Project , Mangalore", and having conducted a thorough study of the job site(s) involved, the site conditions, soil conditions, the climatic conditions, labour, power, water, material and equipment availability, the transport and communication facility, the availability and suitability of borrow areas, the availability of land for right-of-way and temporary office and accommodation quarters and all other factors and facilities and things whatsoever necessary or relative to the formulation of the tender and the performance of work. I/We hereby submit our tender offer for the performance of the proposed work in accordance with the terms and conditions and within the time mentioned in the Tender Documents at the rate(s) quoted by me/us in the accompanying schedules of rates based on the form of schedule (s) of Rates included within the Tender documents and arrived at a Total Contract Value of **(as quoted in E-tendering Portal)**

based on an application of the rates tendered in the accompanying Schedule(s) of Rates to the relative quantities indicated in the form of Schedule (s) of Rates forming part of the Tender Documents.

If the work or any part thereof is awarded to me/us, I/We undertake to perform the work in accordance with the contract document as defined in Form of contract forming part of the Tender Documents and accept the terms and conditions of Contract as laid down therein, and undertake within 10 (ten) days of receipt of Acceptance / Award of Tender to pay to and/or deposit with the Accounts Officer, Mangalore Refinery And Petrochemicals Ltd., Mangalore, a sum which, together with the amount of Earnest Money deposited by me/us in terms hereof, shall make Rupees/- (Rupees.....) as specified in the Acceptance / Award of Tender for the purpose of security deposit, by any one or more of the modes of payments specified in the general conditions of contract, and to commence work at each job site(s) involved within 10 (ten) days of handing over the job site or any part thereof to me/us, and to sign, the formal contract in terms of the form of contract forming part of Tender Documents, within 10 (ten) days of receipt of Letter of



**ENGINEERING, PROCUREMENT AND CONSTRUCTION MANAGEMENT (EPCM) SERVICES FOR
INSTALLATION OF LPG AMINE ABSORBER SYSTEM IN PFCC UNIT AT MRPL, MANGALURU**

Acceptance / Award from or on behalf of Mangalore Refinery And Petrochemicals Ltd., in this behalf failing which Mangalore Refinery and Petrochemicals Ltd., shall be at liberty, without further reference to me/us and without prejudice to any of its rights or remedies, to terminate the contract and/or to forfeit the Earnest Money deposited in terms hereof.

In consideration of the sum of Rupee 1/- (Rupee one only) paid to me/us by Mangalore Refinery And Petrochemicals Ltd., by adjustment in the price of Tender Documents, I/We further undertake to keep my/our this tender offer open for a period of not less than 4/6 (four/six) months from the Schedule date of opening of Tender as specified in the General Instructions to tenderers forming part of the Tender Documents.

I/We hereby further state that I/We/None of us (in the case of partnership firm) was/were employed as Directors of Mangalore Refinery And Petrochemicals Ltd., during the period of 2 (two) years immediately preceding the date hereof or I/We hereby declare that I/Sri....., one of our partners in the case of a partnership firm, was employed as a Director in the Mangalore Refinery And Petrochemicals Ltd. during the period of 2 (two) years immediately preceding the date hereof and that I/Sri..... have/has obtained previous permission of Mangalore Refinery And Petrochemicals Ltd., to participate in this tender.

I/We have annexed to this tender the following documents:

- (i) Schedule of Rates in the prescribed form:
- (ii) Original Power of Attorney or proof of authority of the person who has signed the Tender OR copy of Power of Attorney or duly attested by a Gazetted Officer in proof of authority of the person who has signed the tender;
- (iii) Original Income-tax Clearance certificate OR copy of Income-tax Clearance Certificate duly attested by a Gazetted Officer;
- (iv) Original Sales Tax Clearance Certificate OR copy of Sales-tax Clearance Certificate duly attested by a Gazetted Officer;
- (v) Information regarding tenderer in the form annexed to the Form of Tender;
- (vi) Information regarding experience of work of a comparable nature in the form annexed to Form of Tender:
- (vii) Information regarding construction organization and equipment in for form annexed to the Form of Tender;
- (viii) Solvency Certificate from a Nationalized/Scheduled Bank:
- (ix) Set of Tender Documents, as issued duly signed;
- (x) Any additional documents as listed below;

I/We hereby undertake that the statements made herein and the information given in the Annexures referred to above are true in all respects and that in the event of any such statement or information being found to be incorrect in any particular, the same may be construed to be misrepresentation entitling Mangalore Refinery And Petrochemicals Ltd. to avoid any resultant contract.



**ENGINEERING, PROCUREMENT AND CONSTRUCTION MANAGEMENT (EPCM) SERVICES FOR
INSTALLATION OF LPG AMINE ABSORBER SYSTEM IN PFCC UNIT AT MRPL, MANGALURU**

I/We further undertake as and when called upon by Mangalore Refinery And Petrochemicals Ltd., to produce, for its inspection, original(s) of the document(s) of which copies have been annexed hereto.

I/We confirm having deposited Earnest Money of Rs.....
(Rupees.....) as detailed hereunder: (strike-off
whichever is not applicable.)

By Demand Draft No..... Dated..... Drawn.....
Bank..... Branch.....attached hereto)

Dated this day of2020.

Yours faithfully,

Signature(s) of the Tenderer (s)

Name and designation of authorised person
signing the tender on behalf of the tender(s):

Full name and address of the tenderer(s)

Witness (Signature):

Name in block letters:

Address:

Occupation:



FORM –A1

INFORMATION ABOUT TENDERER

(To be furnished with Tender)

1. In case of Individual
 - 1.1 Name of Business:
 - 1.2 Whether his business is registered:
 - 1.3 Date of Commencement of business:
 - 1.4 Whether he pays Income Tax over Rs.10,000/- per year:
 - 1.5 Whether he is a Director or is related to any Director of MRPL present or retired within the past 2 years.
 - 1.6 Permanent Account Number:
 - 1.7 What are his profits/losses for the past 3 (three) years with a copy of Balance Sheet and Profit & Loss Account for the past 3 (three) years with a copy of the audited balance Sheets and Profit & Loss account for the past 3 (three) years:
 - 1.8 What are his concurrent job commitments:
 - 1.9 How does he propose to finance the work if awarded to him:

2. In case of Partnership
 - 2.1 Name of Partners:
 - 2.2 Whether the partnership is registered:
 - 2.3 Date of establishment of firm:
 - 2.4 If each of the partner of the firm pays Income tax over rs.10,000/- a year and if not, which of them pays the same:
 - 2.5 Whether any partner of the firm is a Director of MRPL present or retired within the past 2 years.
 - 2.6 Permanent Account Number:
 - 2.7 What are the firm's profits/losses for the past 3 (three) years with a copy of Balance Sheet and Profit & Loss Account for the past 3 (three) years:
 - 2.8 What are the firm's concurrent job commitments:
 - 2.9 How does the firm propose to finance the work if awarded to him:

3. In case of Limited Company or Company Limited by Guarantees:
 - 3.1 Amount of paid up capital:
 - 3.2 Name of Directors:
 - 3.3 Date of registration of Company:
 - 3.4 Copies of the Balance Sheet of the company of the last two years:
 - 3.5 Whether any of the Directors of the Company is a Director or is related to any Director of MRPL present or retired within the past 2 years.
 - 3.6 Permanent Account Number:
 - 3.7 What are the Company's profits/losses for the past 3 (three) years with a copy of the audited Balance Sheet for the past 3 (three) years
 - 3.8 What are the company's concurrent job commitments:
 - 3.9 How does the Company propose to finance the work if awarded to it:

Signature of Tenderer
Name & Address of the Tenderer



PROFORMA OF BANK GUARANTEE

(FOR EARNEST MONEY DEPOSIT AS APPLICABLE)
(On non-judicial paper of appropriate value)

To
Mangalore Refinery and Petrochemicals Limited
Mangalore

Dear Sirs,

In consideration of Mangalore Refinery and Petrochemicals Limited, having its Registered Office at Kuthethoor P.O Via Katipalla, Mangalore - (hereinafter called "the Owner" which expression shall include its successors and assigns), having agreed inter alia to consider the tender of (Name of the Tenderer) having its Head Office/Registered Office at (Address of the Tenderer) (Hereinafter called the "Tenderer" which expression shall include its successors and assigns), for the work of..... (Name of the Project/ Work) at..... to be awarded under Tender No..... Upon the Tenderer furnishing an undertaking from the Bank as hereinafter appearing in lieu of cash deposit of the Earnest Money.

We (Name of the Bank), a Bank Constituted/Registered under the Act, having our Head Office/Registered Office at (hereinafter called the "Bank" which expression shall include its successors and assigns), at the request of the Tenderer and with the intent to bind the Bank and its successors and assigns do hereby unconditionally and irrevocably undertake to pay the Owner at Mangalore forthwith on first demand without protest or demur or proof or satisfaction or condition and without reference to the Tenderer, all sums payable by the Tenderer as and by way of Earnest Money to the Owner, up to an aggregate limit of (Amount in figures and words).

AND THE BANK DOETH HEREBY FURTHER AGREE AS FOLLOWS:

1. This Guarantee/Undertaking shall be a continuing guarantee and shall remain in full force and effect for all claims and demands made by the Owner on the Bank until the Owner discharges this Guarantee/Undertaking subject, however, that the Owner shall have no claims under this Guarantee/Undertaking after the midnight of200..... Or any written extension(s) thereof.

PROVIDED that if the aforesaid work tendered for or any part thereof shall be awarded to the Tenderer on or before the said date, whether on the basis of accompanying tender or any other basis, then the validity of this guarantee/undertaking shall stand automatically extended for all claims and demands made by the Owner for further three months.

2. The Owner shall have the fullest liberty without reference to the Bank and without affecting in any way the liability of the Bank under this Guarantee/Undertaking at any time and/or from time to time any wise to postpone and/or vary any of the powers, rights, and obligations exercisable by the Owner against the Tenderer and either to enforce or to forbear from enforcing all or any of the terms and conditions of or governing the said Tender and/or any contract consequent upon any award of work or the said Earnest Money Deposit or the securities available to the Owner or any of them and the Bank shall not be released from its liability under these Presents and the Liability of the Bank hereunder shall remain in full force and effect notwithstanding any exercise by the Owner of the liberty with reference to any or all the matters aforesaid or by reason of any other act, matter or thing whatsoever which under law relating to the sureties or otherwise which could, but for this provision have the effect of releasing the Bank from all or any of its obligations hereunder or any part thereof, and the Bank specifically waives any and all contrary rights whatsoever.



**ENGINEERING, PROCUREMENT AND CONSTRUCTION MANAGEMENT (EPCM) SERVICES FOR
INSTALLATION OF LPG AMINE ABSORBER SYSTEM IN PFCC UNIT AT MRPL, MANGALURU**

3. It shall not be necessary for the Owner to proceed against the Tenderer before proceeding against the Bank and the Guarantee/Undertaking herein contained shall be enforceable against the Bank as principal debtor notwithstanding the existence of any other undertaking or security for any indebtedness of the Tenderer to the Owner and notwithstanding that any such security shall at the time when claim is made against the Bank or proceedings taken against the Bank hereunder, be outstanding or unrealised.
4. The amount stated by the Owner in any demand, claim or notice made with reference to this guarantee shall as between the Bank and the Owner for the purpose of these Presents be conclusive of the amount payable by the Bank to the Owner hereunder.
5. The liability of the Bank to the Owner under this Guarantee/Undertaking shall remain in full force and effect notwithstanding the existence of any difference or dispute between the Tenderer and the Owner, the Tenderer and the Bank and/or the Bank and the Owner or otherwise howsoever touching these Presents or the liability of the Tenderer to the Owner, and notwithstanding the existence of any instructions or purported instructions by the Tenderer or any other person to the Bank not to pay or for any cause withhold or defer payment to the Owner under these Presents, with the intent that notwithstanding the existing of such difference, dispute or instructions, the Bank shall be and remain liable to make payment to the Owner in terms thereof.
6. This Guarantee/Undertaking shall not be determined or affected by the liquidation or winding up or dissolution or change of constitution or insolvency of the Tenderer or any change in the legal constitution of the Bank or the Owner.
7. Without prejudice to any other mode of service, a demand or claim or other communication may be transmitted by the Owner to the Bank either by post or by fax. If transmitted by fax, the transmission shall be complete as soon as acknowledged by the Bank.
8. Notwithstanding anything contained herein:
 - (i) The Bank's liability under this guarantee/undertaking shall not exceed (Amount in figures & words);
 - (ii) The guarantee/undertaking shall remain in force up to _____ and any extension(s) thereof; and
 - (iii) The Bank shall be released and discharged from all liability under this guarantee/undertaking unless a written claim or demand is issued to the Bank on or before _____ or the date of expiry of any extension(s) thereof if this guarantee/undertaking has been extended.

The Bank doth hereby declare that Shri _____ (designation) _____ who is authorised to sign this Guarantee/Undertaking on behalf of the Bank and to bind the Bank thereby.

This _____ day of _____ 20_____.

Yours faithfully

Signature: _____

Name & Designation: _____

Name of the Branch: _____



**ENGINEERING, PROCUREMENT AND CONSTRUCTION MANAGEMENT (EPCM) SERVICES FOR
INSTALLATION OF LPG AMINE ABSORBER SYSTEM IN PFCC UNIT AT MRPL, MANGALURU**

FORM-B1

FORMAT FOR SPECIFIC WORK MEETING THE EXPERIENCE CRITERIA

(AS APPLICABLE IN NIT)

Bidder shall furnish their Experience for similar work with all details and documents as mentioned in this Specific Experience Format which are in conformity with Bidder's Qualification Criteria mentioned in Notice Inviting Tender .In case of more than one work, furnish details for all such Works.

S. NO.	DESCRIPTION	DETAILS
Details of similar works executed by bidder (Complying the requirement of BQC)		
1.	Name of Project and its location	
2.	Description of work	
3.	Name of Owner, Postal Address, Phone/Fax No./E-mail Address	
4.	Name of Consultant, Postal Address, Phone/ Fax No./E-mail Address	
	Contract Value: (a) Awarded (b)Final Executed (c) Component of relevant work experience as Per BQC.	Rs. _____ Rs. _____ Rs. _____
5.	Milestone Dates	•Date of award: _____ •Starting date: _____ •Scheduled Completion Date: _____ •Actual Completion Date: _____ •Reasons for delay, if any: _____ _____ _____ _____



**ENGINEERING, PROCUREMENT AND CONSTRUCTION MANAGEMENT (EPCM) SERVICES FOR
INSTALLATION OF LPG AMINE ABSORBER SYSTEM IN PFCC UNIT AT MRPL, MANGALURU**

S. NO.	DESCRIPTION	DETAILS
6.	Supporting Documents for Experience Criteria	<ul style="list-style-type: none"> Whether copy of Work Order/Contract Agreement enclosed <p align="center">YES NO</p> <p>Ref.no. _____</p> <p>Dated _____</p> <ul style="list-style-type: none"> Whether Completion Certificate enclosed <p align="center">YES NO</p> <p>Ref. No.: _____</p> <p>Dated _____</p> <p>Date of Completion _____</p>
	Supporting Document for Financial Criteria	<ul style="list-style-type: none"> Whether Complete Annual Audited Financial Report Including P& L account is enclosed. <p align="center">YES NO</p> <p>If Yes, submitted for financial years</p> <p>1. _____</p> <p>2. _____</p> <p>3. _____</p>
	Whether Worked as Consultant directly with Client or Sub- Consultant of Consultant	<p>Executed the work as</p> <ul style="list-style-type: none"> Main Consultant <input type="checkbox"/> Sub- Consultant <input type="checkbox"/>
7.	CONFIRMATIONS	BIDDER'S CONFIRMATION
7.1	Confirm that the above work has been completed within the qualifying period as mentioned in NIT	Confirmed



ENGINEERING, PROCUREMENT AND CONSTRUCTION MANAGEMENT (EPCM) SERVICES FOR INSTALLATION OF LPG AMINE ABSORBER SYSTEM IN PFCC UNIT AT MRPL, MANGALURU

7.2	Confirm that the above work is not an In-housework experience.	Confirmed
7.3	Confirm that the information/documentation furnished in this proforma are correct and in case of any original document is required by Owner/MRPL the same shall be submitted for Verification.	Confirmed
7.4	Confirm that all information/documentation for the work to be considered for qualification is Furnished in this proforma along with supporting documents as detailed NIT. Non submission of above required information/ documentation may lead to rejection of bid	Confirmed
7.5	Confirm the submission of following Formats/Certificates, as applicable towards fulfilment of Bidder Qualification Criteria: (i) Statutory Document (ii) Notarized document	If Yes, (Please tick mark \surd the applicable) YES <input type="checkbox"/> NO <input type="checkbox"/> YES <input type="checkbox"/> NO <input type="checkbox"/>
7.6	Confirm that all documents furnished by the bidder in support of meeting the experience & financial criteria of BQC have been duly certified by the Statutory Auditor of the bidder or a practicing Chartered Accountant (not being an employee or a Director or not having any interest in the bidder's company/ firm) where audited accounts are not mandatory as per law or Notarized by a Public Notary in bidder's Country or self-certified by CEO or CFO or Company Secretary of the bidder (Limited company only) as per the provision of NIT.	Confirmed

Note: Bidder to use separate format for different works.

SIGNATURE OF BIDDER : _____

NAME OF BIDDER : _____

COMPANYSEAL : _____



ANNEXURE TO FORM-B1

DELETED



ANNUAL TURNOVER STATEMENT

The bidder shall indicate herein his annual turnover during preceding 3 years based on the audited balance sheet/profit & loss account statement.

A. FINANCIAL DETAILS

1.	FINANCIAL YEAR/ YEAR ENDING	ANNUAL TURNOVER (RS.)
	Year 1 (20 - 20)	
	Year 2 (20 - 20)	
	Year 3 (20 - 20)	
NET WORTH OF IMMEDIATE PRECEDING YEAR AS PER AUDITED FINANCIAL RESULT		

NOTES:

- i) **Net worth** means paid up share capital, Share Application Money pending allotment* and reserves# less accumulated losses and deferred expenditure to the extent not written off.



ENGINEERING, PROCUREMENT AND CONSTRUCTION MANAGEMENT (EPCM) SERVICES FOR INSTALLATION OF LPG AMINE ABSORBER SYSTEM IN PFCC UNIT AT MRPL, MANGALURU

Reserves to be considered for the purpose of networth shall be all reserves created out of the profits and securities premium account but shall not include reserves created out of revaluation of assets, write back of depreciation and amalgamation.

*Share Application Money pending allotment will be considered only in respect of share to be allotted.

Accordingly, the definition of Net worth shall be as follows:

Paid up share capital	XXXX
Add: Share Application Money pending allotment	XXX
Add: Reserves (As defined Above)	XXXX
Less: Accumulated Losses	XX
Less: Deferred Revenue Expenditure to the extent not written off	XX
Net worth	XXXX

(Sign & Stamp of Bidder)



ENGINEERING, PROCUREMENT AND CONSTRUCTION MANAGEMENT (EPCM) SERVICES FOR INSTALLATION OF LPG AMINE ABSORBER SYSTEM IN PFCC UNIT AT MRPL, MANGALURU

FORM-C

COMPLIANCE TO BID REQUIREMENT

NAME OF WORK:

BIDDING DOC. NO.:

We hereby agree to fully comply with, abide by and accept without variation, deviation or reservation all technical, commercial and other conditions whatsoever of the Bidding Documents and Amendment(s) / Addendum(s) to the Bidding Documents, if any, for subject work issued by MRPL.

We here by further confirm that any terms and conditions if mentioned in our bid (Un-priced as well as Priced Part) shall not be recognized and shall be treated as null and void.

SIGNATURE OF BIDDER : _____

NAME OF BIDDER : _____

COMPANY SEAL : _____



ENGINEERING, PROCUREMENT AND CONSTRUCTION MANAGEMENT (EPCM) SERVICES FOR INSTALLATION OF LPG AMINE ABSORBER SYSTEM IN PFCC UNIT AT MRPL, MANGALURU

FORM-D (Sheet 1 of 2)

**EXCEPTIONS AND DEVIATIONS
(FOR COMMERCIAL PART)**

SL.NO	REFERENCE OF BID DOCUMENT		SUBJECT	DEVIATIONS
	PAGE NO.	CLAUSE NO.		

NOTE: This shall be submitted separately for Commercial & Technical Sections

SIGNATURE OF BIDDER :

NAME OF BIDDER :

COMPANY SEAL :



ENGINEERING, PROCUREMENT AND CONSTRUCTION MANAGEMENT (EPCM) SERVICES FOR INSTALLATION OF LPG AMINE ABSORBER SYSTEM IN PFCC UNIT AT MRPL, MANGALURU

FORM-D (Sheet 2 of 2)

**EXCEPTIONS AND DEVIATIONS
(FOR TECHNICAL PART)**

SL.NO	REFERENCE OF BID DOCUMENT		SUBJECT	DEVIATIONS
	PAGENO.	CLAUSENO.		

NOTE: This shall be submitted separately for Commercial & Technical Sections

SIGNATURE OF BIDDER :

NAME OF BIDDER :

COMPANY SEAL : _____



FORM-E

CHECKLIST FOR SUBMISSION OF BID

Bidder is requested of ill this check list and ensure that all details/ documents have been furnished as called for in the Bidding Document along with duly filled in, signed & stamped check list **with each copy of the "Unpriced bid (Part-I)"**.

Please tick the box and ensure compliance:

- (1) Form of Bid as per FORM-A
Submitted
- (2) Power of Attorney in Favour of the person who as signed the bid.
Submitted
- (3) Information about Bidder as per FORM-A1
Submitted
- (4) EMD
Submitted
- (5) EMD details
DD No: _____
BG No: _____
Dated: _____
Amount: _____
Validity: _____
Name & Address of issuing bank:

- (6) Registered under Micro or Small Enterprise Development Act 2006 and claiming exemption From payment of EMD? Yes / No
If yes, copy of NSIC/ DIC / UAM registration Certificate uploaded Submitted/Not Submitted/Not Applicable
- (7) Integrity Pact along with Affidavit (If Required as per Bidding Document)
Submitted
- (8) Documentation against Bidder meeting the BQC (Technical & Commercial) stipulated in NIT per FORM-B1 & B2 and as per NIT
(a) Submitted
(b) Not Submitted
- (9) Compliance to Bid Requirement as per FORM-C.
Submitted



**ENGINEERING, PROCUREMENT AND CONSTRUCTION MANAGEMENT (EPCM) SERVICES FOR
INSTALLATION OF LPG AMINE ABSORBER SYSTEM IN PFCC UNIT AT MRPL, MANGALURU**

- (10) Exceptions / Deviations as per FORM-D both technical and commercial Part (Un-priced)
- Submitted
- (11) Reply to commercial questionnaire as per FORM-F with Bidder's Reply/ confirmation for each SI.Nos.
- Submitted
- (12) Details of PF as per FORM-G
- Submitted
- (13) Employees Provident Fund Registration Certificate Submitted / Not Submitted /Not applicable
- (14) If EPF Registration is not available, duly acknowledged (by the EPF Authorities) copy of application or undertaking on Bidder's Company letterhead for obtaining the same in case of award Of contract Submitted / Not Submitted / Not available
- PF Code No: _____
- (15) ESI obtained from the Competent Authority Submitted / Not Submitted /Not applicable
- (16) If ESI No is not available, duly acknowledged (by ESI Authority) Copy of application or undertaking on Bidder's Company Letterhead for obtaining the same in case of award of contract submitted / Not Submitted / Not available
- ESI No: _____
- (17) Declaration by the Bidder as per FORM-J
- Submitted
- (18) Declaration about current litigation/arbitration
- (19) Blank copy (without price) of Price Part
- Submitted
- (20) MOU/AOA/Partnership Deed
- Submitted
- (21) Declaration by Bidder regarding Blacklisting / Holiday listing
- Submitted, if Applicable
- (22) Undertaking for non-engagement of child labour as per FORM-K
- Submitted
- (23) Bidder's Bank Details as per FORM-L
- Submitted



**ENGINEERING, PROCUREMENT AND CONSTRUCTION MANAGEMENT (EPCM) SERVICES FOR
INSTALLATION OF LPG AMINE ABSORBER SYSTEM IN PFCC UNIT AT MRPL, MANGALURU**

- (24) Reply to Technical questionnaire (if enclosed in technical part) with Bidder's Reply/ Confirmation for each SI.No.
Submitted (If applicable)
- (25) Technical Details/Documents specified in Technical part.
Submitted (If applicable)
- (26) Cancelled cheque of bidders bank account
Submitted
- (27) Copy of PAN Card
Submitted
- (28) Letter of Waiver as per Form-N
Submitted

CONFIRM THE FOLLOWING

- (1) All pages of the bid have been page numbered in sequential Manner YES
- (2) Master Index and Copy of Addendum/ Amendment, if any, Has been submitted along with offer, duly signed and stamped On each page. YES
- (3) Blank copy (without price) of Price bid duly signed and stamped On each page has been submitted. YES
- (4) The bid has been submitted in line with requirements as specified in Instructions to Bidders YES

SIGNATURE OF BIDDER : _____

NAME OF BIDDER : _____

COMPANY SEAL : _____



**ENGINEERING, PROCUREMENT AND CONSTRUCTION MANAGEMENT (EPCM) SERVICES FOR
INSTALLATION OF LPG AMINE ABSORBER SYSTEM IN PFCC UNIT AT MRPL, MANGALURU**

FORM-F

COMMERCIAL QUESTIONNAIRE

Bidder's reply/ confirmation as furnished in the Commercial Questionnaire (CQ) shall supersede the stipulations mentioned elsewhere in their bid.

SL. NO.	MRPL'S QUERY	BIDDER'S REPLY/ CONFIRMATION
1.0	Confirm that your Bid is valid for 120 days months from the last date of submission of Bid.	
2.0	Confirm that Earnest Money Deposit (EMD)/Indemnity Bond (as applicable) as per bid stipulations have been furnished along with bid.	
3.0	Confirm that the following documents are submitted with Part-I:	
a)	All documents as per Form- E (CHECKLIST) & Clause 9.5 of I.T.B.	
b)	Master Index as enclosed with NIT is submitted in unpriced part duly signed and stamped on each page.	
c)	Copy of Addendum/ Amendments as a token of acceptance (Applicable, if issued).	
4.0	Confirm that price has been submitted in an e-tender portal as per the manner stated in the ITB.	
5.0	Schedule of Rates/Price	
a)	Price must be filled in the Price bid Form uploaded in the e-tender portal. Please note that the format is not to be edited /altered by the bidder.	
b)	Confirm that rate/price has been quoted in FORM SP-0 & FORM SP-1	
c)	Confirm that deviation/terms & conditions are not mentioned in the price part. In case any terms and condition is mentioned in the price part, the same shall be treated as null and void.	
6.0	Confirm your compliance to TERMS AND CONDITIONS of Bidding Document .Confirm your compliance to critical stipulations of bidding document as mentioned in ITB.	



**ENGINEERING, PROCUREMENT AND CONSTRUCTION MANAGEMENT (EPCM) SERVICES FOR
INSTALLATION OF LPG AMINE ABSORBER SYSTEM IN PFCC UNIT AT MRPL, MANGALURU**

SL. NO.	MRPL'S QUERY	BIDDER'S REPLY/ CONFIRMATION
7.0	Confirm that you have studied complete Bidding Document including Technical and Commercial part and your Bid is in accordance with the requirements of the Bidding Document.	
8.0	Confirm your compliance to total Scope of Services mentioned in the Bidding Document	
9.0	Confirm your acceptance for Scope of Services mentioned in the Bidding Document	
10.0	Confirm your acceptance for Time Schedule as mentioned in Bidding Document.	
11.0	Confirm that your quoted price includes all taxes & duties as applicable for this services/ Work in accordance with the provision of General Conditions of Contract (GCC) / Conditions of contract	
12.0	Confirm that your quoted price includes all types of insurance as per the provisions of GCC/ Conditions of contract .	
13.0	Confirm that all costs resulting from safe execution of Work, such as safety practices, use of protective clothing, safety glasses and helmet, safety precaution taken during monsoon, or any other safety measures to be undertaken are included in the quoted rates	
14.0	Confirm that while submitting your price, you have taken consideration of scope of services/ work and technical requirement mentioned in Bidding Document	
15.0	Confirm that you have your own QA/QC programme for executing this work. In case of award of work, you will submit all QA/QC documents as per specification.	
16.0	We confirm that we are not involved in any Litigation or Arbitration. OR We confirm that the current litigation/ arbitration in which We are involved will not have any impact in work being tendered or in entering into contract during the validity of offer and performing the contract till all contractual Obligations under contract are performed.	
17.0	Confirm that the Bidder is not under liquidation, court receivership or similar proceedings.	



**ENGINEERING, PROCUREMENT AND CONSTRUCTION MANAGEMENT (EPCM) SERVICES FOR
INSTALLATION OF LPG AMINE ABSORBER SYSTEM IN PFCC UNIT AT MRPL, MANGALURU**

SL. NO.	MRPL'S QUERY	BIDDER'S REPLY/ CONFIRMATION
18.0	Confirm Compliance to the following: i) Minimum required equipment's, tools & tackles to be mobilized as required. ii) Key Construction Manpower to be deployed at site as per SCC.	
19.0	Please confirm that your Bid does not have any deviation to terms and conditions of the Bidding Document.	
20.0	Confirm that you have uploaded the Bid on e-tender portal as per the instructions given in ITB.	
21.0	None of the Directors of BIDDER is a relative of any Director of Owner or the BIDDER is a firm in which any Director of Owner or his relative is a Partner or the BIDDER is a private company in which none of director of Owner is a member or Director.	
22.0	Confirm that all authenticated documents submitted for meeting the BQC are certified as per the authentication requirement defined in the bidding document.	
23.0	Bidder to confirm the submission of the following : a) Bank Guarantee for PBG upon Placement of Order. b) Bank Guarantee for Mobilisation Advance, if applicable.	<input type="checkbox"/> <input type="checkbox"/>

SIGNATURE OF BIDDER : _____

NAME OF BIDDER : _____

COMPANY SEAL : _____



FORM- G

DETAILS OF P.F. REGISTRATION

Bidder to furnish details of Provident Fund Registration:

PF Registration No. :

District & State :

We hereby confirm that the above PF Account is under operation presently and shall be used for all. PF related activities for the labour engaged by us in the present work (if awarded to us).

SIGNATURE OF BIDDER: _____

NAME OF BIDDER : _____

COMPANY SEAL : _____



ENGINEERING, PROCUREMENT AND CONSTRUCTION MANAGEMENT (EPCM) SERVICES FOR INSTALLATION OF LPG AMINE ABSORBER SYSTEM IN PFCC UNIT AT MRPL, MANGALURU

FORM – H

BIDDER'S QUERIES (TECHNICAL)

SL. NO.	BIDDING DOCUMENT		SUBJECT	BIDDER'S QUERY	OWNER'S REPLY
	PAGENO.	CLAUSENO.			

NOTE: Bidder's Queries may be sent by e-mail to: gmpai@mrpl.co.in
Submit the queries one day prior to the Pre-bid meeting



ENGINEERING, PROCUREMENT AND CONSTRUCTION MANAGEMENT (EPCM) SERVICES FOR INSTALLATION OF LPG AMINE ABSORBER SYSTEM IN PFCC UNIT AT MRPL, MANGALURU

FORM-I

BIDDER'S QUERIES (COMMERCIAL)

SL. NO.	BIDDINGDOCUMENT		SUBJECT	BIDDER'SQUERY	OWNER'SREPLY
	PAGENO.	CLAUSENO.			

NOTE: Bidder's Queries may be sent by e-mail to: sanjay@mrpl.co.in / hari_kumar@mrpl.co.in

*Submit the queries one day prior to Pre-bid meeting



ENGINEERING, PROCUREMENT AND CONSTRUCTION MANAGEMENT (EPCM) SERVICES FOR INSTALLATION OF LPG AMINE ABSORBER SYSTEM IN PFCC UNIT AT MRPL, MANGALURU

FORM-J

DECLARATION BY THE BIDDER

We (Name of the Bidder) here by represent that we have gone through and understood the Bidding Document (which is in two Parts) in Commercial Part (including Price)) and Technical Part and that our Bid has been prepared accordingly in compliance with the requirement stipulated in the said documents.

We are submitting Master Index of Bidding Document as part of our Bid, duly signed and stamped on each page in token of our acceptance. We undertake that Commercial Part (including Price) and Technical Part of the Bidding Document shall be deemed to form part of our bid and in the event of award of work to us, the same shall be considered for constitution of Contract Agreement. Further, we shall sign and stamp each page of above Parts of Bidding Document as a token of Acceptance and as a part of the Contract in the event of award of Contract to us.

We further confirm that we have indicated prices in Schedule of prices / Schedule of Rates (Short Description) which is print out of Short Description of SOR with prices, considering detailed description of items given in Schedule of Rates (Detailed Description) including Summary of Price and submitted in Price Bid in separately sealed envelope/in EPS portal. We confirm that price quoted by us includes price for all works/activities/supply etc. as mentioned in tender / item description of the items in Schedule of Rates (with detailed tem description) which has been issued to us in CD (PDF File) or downloaded as per the Bidding Document.

SIGNATURE OF BIDDER : _____

NAME OF BIDDER : _____

COMPANY SEAL : _____

NOTE: This declaration should be signed by the Bidder's representative who is signing the Bid.



FORM-K

UNDERTAKING FOR NON-ENGAGEMENT OF CHILD LABOUR

Name of Work:

Bidding Doc. No.:

I/we hereby declare that:

- a) We are committed to elimination of child labour in all its forms.
- b) Neither we nor any of our nominated sub-contractor(s) are engaging Child Labour in any of our work(s) in terms of the provisions of The Child Labour (Prohibition and Regulation) Act, 1986 and other applicable laws.
- c) We as well as our nominated sub-contractor(s) undertake to fully comply with provisions of The Child Labour (Prohibition and Regulation) Act, 1986 and other applicable labour laws, in case the work is awarded to us.
- d) It is understood that if / We, either be for re award or during execution of Contract, commit at transgression through violation of Article b/c above or in any other form, such as to put my/our reliability or credibility in question, the Owner is entitled to disqualify us from the Tender process or terminate the Contract, if already executed or exclude me /us from future contract award processes .The imposition and duration of the exclusion will be determined by the severity of transgression and determined by the Owner. Such exclusion may be for a period of 1 year to 3 years as per the procedure prescribed in the guidelines for holiday listing of the Owner.
- e) I/We accept and undertake to respect and uphold the Owner's absolute right to resort to and impose such exclusion.

Place:

Signature of Bidder:

Date:

Name of Signatory



**ENGINEERING, PROCUREMENT AND CONSTRUCTION MANAGEMENT (EPCM) SERVICES FOR
INSTALLATION OF LPG AMINE ABSORBER SYSTEM IN PFCC UNIT AT MRPL, MANGALURU**

FORM-L

VENDOR FORM FOR ELECTRONIC FUNDS TRANSFER PAYMENT & TAX DETAILS

Please use additional copies of this form if your Company has additional Branches/ Divisions dealing with MRPL/ if Material/ Service/ Invoice will be provided from different GST Nos.

Vendor data – ver-8

To: GGM- Materials	
Mangalore Refinery & Petrochemicals Ltd.,Kuthethoor P.O., via Katipalla, Mangaluru. (Karnataka), Pin Code-575030, INDIA	
The following is a confirmation/ updation of our bank account details and I/we hereby affirm our choice to opt for payment of amounts due to us under various contracts through electronic mode.	
1. Vendor/ Contractor particulars:	
(i)	Name of the Company:
(ii)	Corporate Identity No. (CIN)
(iii)	Existing Vendor Code (given by MRPL)
(iv)	Complete Postal Address:
(v)	Pin code/ ZIP code:
(vi)	Telephone nos. (with country/area codes):
(vii)	Fax No.: (with country/area codes):
(viii)	Cell phone Nos.:
(ix)	Contact persons /Designation:
(x)	Email IDs:
2. Bank Account Particulars:	
(i)	Name of the Account holder:
(ii)	Complete Bank Account No. (for Electronic Funds Transfer):
(iii)	Account type :
(iv)	Bank Name :
(v)	Bank Branch:
(vi)	Bank Branch Contact Nos.:
(vii)	11 Digit IFS Code (for Bank Branches in India)
(viii)	Swift Code (for Bank Branches not in India)
3. Tax Registration numbers: *(Please fill in the applicable fields and attach relevant proofs)	
(i)	Income Tax PAN no.:
(ii)	Vendor type as per GST Act (tick any one) <input type="checkbox"/> Registered <input type="checkbox"/> Not Registered <input type="checkbox"/> Compounding <input type="checkbox"/> SEZ
(iii)	GST No.:
(iv)	Registered address as per GST No.
(v)	Contact Names, Nos.& email IDs for GST matters (Please mention primary and secondary contacts):



**ENGINEERING, PROCUREMENT AND CONSTRUCTION MANAGEMENT (EPCM) SERVICES FOR
INSTALLATION OF LPG AMINE ABSORBER SYSTEM IN PFCC UNIT AT MRPL, MANGALURU**

	Accounts Deptt.	1. 2.
	Material Dispatch Deptt./ Services Deptt.	1. 2.
(vi)	Are you registered under TreDS	No/Yes with RXIL/ A-TREDS/M1xchange 10 digit Reg No-

4. Organization information (MSMEs refer to Micro, Small and Medium Enterprises Development Act, 2006):

(i)	Company /Partnership Firm /Proprietary Concern / Society/Trust /NGO/Others (Please Specify):	
(ii)	Whether Proprietor/ Partner belongs to SC/ ST category. (Please specify names and percentage of shares held by SC/ST Partners):	
(iii)	Micro/Small / Medium Enterprise/ SSI/ Govt. Deptt./ PSU/ Others:	
(iv)	Name of MSME Registering Body (NSIC/ DIC/ KVIC/KVIB etc.):	
(v)	MSME Registration no. (with copy of registration)	
(vi)	Udyog Aadhaar Memorandum no.	
(vii)	MSME-Women Entrepreneur	No/Yes
(viii)	Start-Up recognized by DIPP, Ministry of Commerce, Govt of India	No/Yes, copy of certificate from DIPP attached

I/we hereby confirm that the particulars given above are correct and complete and also undertake to advise any future changes to the above details.

Name, Seal & Signature of Authorized Signatory for the Vendor with date

TO BE FILLED BY AUTHORISED BANKER OF THE VENDOR:

Certified that the Particulars as in Sr. No. 2 above are correct as per our records

Bank Seal & Signature with date



INTEGRITY PACT

Between

Mangalore Refinery and Petrochemicals Ltd (MRPL) hereinafter referred to as "The Principal",

And

M/s..... Hereinafter referred to as "The Bidder/Contractor"

Preamble

The Principal intends to award, under laid down organizational procedures, contract/s for procurement of products / services vide tender No.**dated**..... The Principal values full compliance with all relevant laws and regulations, and the principles of economic use of resources, and of fairness and transparency in its relations with its Bidder/s and Contractor/s.

In order to achieve these goals, the Principal cooperates with the renowned international Non-Governmental Organization "Transparency International" (TI). Following TI's national and International experience, the Principal will appoint an external independent Monitor who will monitor the tender process and the execution of the contract for compliance with the principles mentioned above.

Section 1 - Commitments of the Principal

(1)The Principal commits itself to take all measures necessary to prevent corruption and to observe the following principles:-

1. No employee of the Principal, personally or through family members, will in connection with the tender for, or the execution of a contract, demand, take a promise for or accept, for him/herself or third person, any material or immaterial benefit which he/she is not legally entitled to.
2. The Principal will, during the tender process treat all Bidders with equity and reason. The principal will in particular, before and during the tender process, provide to all Bidders the same information and will not provide to any bidder confidential/additional information through which the Bidder could obtain an advantage in relation to the tender process or the contract execution.
3. The Principal will exclude from the process all known prejudiced persons.

(2)If the Principal obtains information on the conduct of any of its employees which is a criminal offence under the relevant Anti-Corruption Laws of India or if there be a substantive suspicion in this regard, the Principal will inform its Vigilance Office and in addition can initiate disciplinary actions.

For "The Principal"

For "The Bidder/Contractor"



Section 2 – Commitments of the Bidder/Contractor

- (1)The Bidder / Contractor commits itself to take all measures necessary to prevent corruption. He commits himself to observe the following principles during his participation in the tender process and during the contract execution.
1. The Bidder/Contractor will not, directly or through any other person or firm, offer, promise or give to any of the Principal's employees involved in the tender process or the execution of the contract or to any third person any material or immaterial benefit which he/she is not legally entitled to, in order to obtain in exchange any advantage of any kind whatsoever during the tender process or during the execution of the contract.
 2. The Bidder/Contractor will not enter with other Bidders into any undisclosed agreement or understanding, whether formal or informal. This applies in particular to prices, specifications, certifications, subsidiary contracts, submission or non-submission of bids or any other actions to restrict competitiveness or to introduce cartellization in the bidding process.
 3. The Bidder/Contractor will not commit any offence under the relevant Anti-corruption Laws of India; further the Bidder/Contractor will not use improperly, for purposes of competition or personal gain, or pass on to others any information or document provided by the Principal as part of the business relationship, regarding plans, technical proposals and business details, including information contained or transmitted electronically.
 4. The Bidder / Contractor will, when presenting his bid, disclose any and all payments he has made, is committed to or intends to make to agents, brokers or any other intermediaries in connection with the award of the contract.
- (2)The Bidder / Contractor will not instigate third persons to commit offences outlined above or be an accessory to such offences.

Section 3 - Disqualification from tender process and exclusion from future contracts

If the Bidder, before contract award has committed a transgression through a violation of Section 2 or in any other form such as to put his reliability or credibility as Bidder into question, the Principal is entitled to disqualify the Bidder from the tender process or to terminate the contract, if already signed, for such reason.

- (1)If the Bidder / Contractor has committed a transgression through a violation of Section 2 such as to put his reliability or credibility into question, the principal is entitled also to exclude the Bidder / Contractor from future contract award processes. The imposition and duration of the exclusion will be determined by the severity of the transgression. The severity will be determined by the circumstances of the case, in particular the number of transgressions, the position of the transgressors within the company hierarchy of the Bidder and the amount of the damage. The exclusion will be imposed for a minimum of 6 months and maximum of 3 years.
- (2)A transgression is considered to have occurred if the Principal after due consideration of the available evidence, concludes that no reasonable doubt is possible.
- (3)The Bidder accepts and undertakes to respect and uphold the principal's absolute right to resort to and impose such exclusion and further accepts and undertakes not to challenge or question such exclusion on any ground, including the lack of any hearing before the decision to resort to such exclusion is taken. This undertaking is given freely and after obtaining independent legal advice.
- (4)If the Bidder / Contractor can prove that he has restored / recouped the damage caused by him and has installed a suitable corruption prevention system, the principal may revoke the exclusion prematurely.

For "The Principal"

Tender No: 3200000464

For "The Bidder/Contractor"

Bidder Seal & Signature



Section 4 - Compensation for Damages

- (1) If the Principal has disqualified the Bidder from the tender process prior to the award according to Section 3, the Principal is entitled to demand and recover from the Bidder liquidated damages equivalent to Earnest Money Deposit / Bid Security.
- (2) If the Principal has terminated the contract according to Section 3, or if the Principal is entitled to terminate the contract according to Section 3, the Principal shall be entitled to demand and recover from the Contractor liquidated damages equivalent to Security Deposit / Performance Bank Guarantee.
- (3) The bidder agrees and undertakes to pay the said amounts without protest or demur subject only to condition that if the Bidder / Contractor can prove and establish that the exclusion of the Bidder from the tender process or the termination of the contract after the contract award has caused no damage or less damage than the amount of the liquidated damages, the Bidder / Contractor shall compensate the principal only to the extent of the damage in the amount proved.

Section 5 - Previous transgression

- (1) The Bidder declares that no previous transgressions occurred in the last 3 years with any other Company in any country conforming to the TI approach or with any other Public Sector Enterprise in India that could justify his exclusion from the tender process.
- (2) If the Bidder makes incorrect statement on this subject, he can be disqualified from the tender process or the contract, if already awarded, can be terminated for such reason.

Section 6 - Equal treatment of all Bidders / Contractors / Subcontractors

- (1) The Bidder / Contractor undertakes to demand from all subcontractors a commitment in conformity with this Integrity Pact, and to submit it to the Principal before contract signing.
- (2) The Principal will enter into agreements with identical conditions as this one with all Bidders, Contractors & Subcontractors.
- (3) The Principal will disqualify from the tender process all bidders who do not sign this pact or violate its provisions.

Section 7 - Criminal charges against violating Bidders / Contractors / Subcontractors

If the Principal obtains knowledge of conduct of a Bidder, Contractor or Subcontractor, or of an employee or a representative or an associate of a Bidder, Contractor or Subcontractor which constitutes corruption, or if the Principal has substantive suspicion this regard, the Principal will inform the Vigilance Office.

For "The Principal"

For "The Bidder/Contractor"



Section 8 - External Independent Monitor / Monitors (three in number depending on the size of the contract)

(to be decided by the Chairperson of the Principal)

- (1) The Principals appoints competent and credible external independent Monitor for this Pact. The task of the Monitor is to review independently and objectively, whether and to what extent the parties comply with the obligations under this agreement.
- (2) The Monitor is not subject to instructions by the representatives of the parties and performs his functions neutrally and independently. He reports to the Chairperson of the Board of the Principal.
- (3) The Contractor accepts that the Monitor has the right to access without restriction to all project documentation of the Principal including that provided by the Contractor. The Contractor will also grant the Monitor, upon his request and demonstration of a valid interest, unrestricted and unconditional access to his project documentation. The same is applicable to Subcontractors. The Monitor is under contractual obligation to treat the information and documents of the Bidder / Contractor / Subcontractor with confidentiality.
- (4) The Principal will provide to the Monitor sufficient information about all meetings among the parties related to the Project provided such meetings could have an impact on the contractual relations between the principal and the Contractor. The parties offer to the Monitor the option to participate in such meetings.
- (5) As soon as the Monitor notices, or believes to notice, a violation of this agreement, he will so inform the Management of the Principal and request the Management to discontinue or heal the violation, or to take other relevant action. The monitor can in this regard submit non-binding recommendations. Beyond this, the Monitor has no right to demand from the parties that they act in a specific manner, refrain from action or tolerate action. However the Independent External Monitor shall give an opportunity to the bidder / contractor to present their case before making its recommendation to the Principal.
- (6) The Monitor will submit a written report to the Chairperson of the Board of the Principal within 8 to 10 weeks from the date of reference or intimation to him by the 'principal' and, should the occasion arise, submit proposals for correcting problematic situations.
- (7) Monitor shall be entitled to compensation on the same terms as being extended to/provided to Outside Expert Committee members/Chairman as prevailing with Principal.
- (8) If the Monitor has reported to the Chairperson of the Board a substantiated suspicion of an offence under relevant Anti-corruption Laws of India, and the Chairperson has not, within reasonable time, taken visible action to proceed against such offence or reported it to the Vigilance Office, the Monitor may also transmit this information directly to the Central Vigilance Commissioner, Government of India.
- (9) The word "Monitor" would include both singular and plural.

Section 9 – Pact Duration

This Pact begins when both parties have legally signed it. It expires for the Contractor 12 months after the last payment under the respective contract, and for all other Bidders 6 months after the contract has been awarded.

If any claim is made/lodged during this time, the same shall be binding and continue to be valid despite the lapse of this pact as specified above, unless it is discharged / determined by Chairperson of the Principal.

For "The Principal"

Tender No: 3200000464

For "The Bidder/Contractor"

Bidder Seal & Signature



Section 10 – Other Provisions

- (1) This agreement is subject to Indian Law, Place of performance and jurisdiction is the Registered Office of the Principal, i.e. Mangalore. The Arbitration clause provided in the main tender document / contract shall not be applicable for any issue / dispute arising under Integrity Pact.
- (2) Changes and supplements as well as termination notices need to be made in writing. Side Agreements have not been made.
- (3) If the Contractor is a partnership or a consortium, this agreement must be signed by all partners or consortium members.
- (4) Should one or several provisions of this agreement turn out to be invalid, the remainder of this agreement remains valid. In this case, the parties will strive to come to an agreement to their original intentions.

For "The Principal"

For "The Bidder/Contractor"
(Name & Signature with Seal)

Place: Mangaluru

Witness 1:.....

Date:.....

Witness 2:.....



FORM-M2

FORMAT FOR FURNISHING AFFIDAVIT W.R.T. INTEGRITY PACT

FORMAT OF AFFIDAVIT

**AFFIDAVIT OF..... S/o D/o , resident of
..... EMPLOYED ASWITH
..... HAVING OFFICE AT
.....PIN**

I, the above named deponent do hereby solemnly affirm and state as under:-

- 1. That I am the authorized representative and signatory of M/s**
- 2. Bidding entity M/s _____ is not involved in any case of transgression in terms of Integrity Pact
Submitted for tender No 3200000464**
- 3. I depose accordingly,**

DEPONENT

VERIFICATION

**I,..... the deponent above named, do hereby verify that the factual
Contents of this Affidavit are true and correct. No part of it is false and nothing material has
been concealed there from.**

Verified at on this day of 20

DEPONENT

[On non-judicial stamp paper of appropriate value & duly notarized]



FORM-N

FORMAT OF LETTER OF WAIVER

(ON LETTERHEAD OF BIDDER)

Name of Work: -----

Bidding Document No :-----

We *hereby agree to fully comply with, abide by and accept without variation, deviation or reservation all technical, commercial and other conditions whatsoever of the tender documents of Tender no and all Addenda issued by MRPL.

We further hereby waive, withdraw and abandon any and all deviations, variations, objections or reservations whatsoever thereto here to-before set out, given or indicated in our offer, clarifications, correspondence, communications, or otherwise with a view that the price bid submitted may be treated to conform in all respects, with the terms and conditions of the said tender documents including all Addenda.

We further hereby confirm that the price quoted in the price bid is as per the provisions of the tender document and there is no deviation to the provisions in the price bid.

**

For & on behalf of

Authorised signatory of Bidder

* Here fill in the name of bidder.

** The Letter of Waiver must be signed by the person(s) authorised to sign



FORM- P

(TO BE GIVEN ON BIDDER'S LETTER HEAD)

PROFORMA OF DECLARATION OF BLACK LISTING/HOLIDAY LISTING

In the case of a Proprietary Concern:

I hereby declare that neither I in my personal name or in the name of my Proprietary concern, M/s , submitting the Bid / Tender nor any other concern in which I am Proprietor nor any partnership firm in which I am involved as a Managing partner have been placed on blacklist or holiday list declared by any Government Department / Quasi-Government / Public Sector Undertaking or its Administrative Ministry (presently the Ministry of Petroleum & Natural Gas) / Regulatory authorities except as indicated below: (Here give particulars of banning or blacklisting or holiday listing and in the absence thereof state "NIL")

In the case of a Partnership Firm :

We hereby declare that neither we, M/s..... , submitting the Bid / Tender nor any partner involved in the management of the said firm either in his individual capacity or as proprietor or managing partner of any firm or concern have or has been placed on blacklist or holiday list declared by any Government Department / Quasi-Government / Public Sector Undertaking or its Administrative Ministry (presently the Ministry of Petroleum & Natural Gas)/ Regulatory Authorities except as indicated below: (Here give particulars of banning or blacklisting or holiday listing and in the absence thereof state "NIL")

In the case of a Company :

We hereby declare that we have not been placed on any holiday list or black list declared by any Government Department / Quasi-Government / Public Sector Undertaking or its Administrative Ministry (presently the Ministry of Petroleum & Natural Gas) / Regulatory authorities except as indicated below:

(Here give particulars of banning or blacklisting or holiday listing and in the absence thereof state "NIL")

Any false information will be liable for rejection of bid, severe action like Forfeiture of EMD, Cancellation of the Order, Forfeiture of Security deposit including Black listing of the Bidder Company in all ONGC /MRPL establishments.

Signature of Bidder_____

Name of Signatory: _____

Place:

Date:



FORM-Q

(ON LETTERHEAD OF BIDDER)

We confirm that we are not involved in any Litigation or Arbitration.

OR

We confirm that the current litigation/ arbitration in which we are involved will not have any impact in work being tendered or in entering into contract during the validity of offer and performing the contract till all contractual Obligations under contract are performed.

For & on behalf of

Authorised signatory of Bidder



STATEMENT OF CREDENTIALS

Tenderers should fill their technical offer by providing all information as follows (If not applicable-
Please mention as 'N/A') ;

SI No	Particulars	Details
1	Name of the Firm	
2	Nature of the Firm (State whether Limited Company, partnership Firm, Co-op. Society or Sole Proprietor, Photocopies of documents Confirming constitution of the firm to be Enclosed)	
3	Year of Establishment	
4	Registration Number, if any	
5	Registered Postal Address	
6	Telegraphic Address, if any	
7	Telephone No. (s)	
8	Fax No. (s), if any	
9	E-mail ID, if any	
10	Address of Branches, if any	
11	Address on which Order /LOA to be placed	
12	Name of Directors/ partners / Proprietor (as The case may be) with address & Telephone No.(s).	
13	Permanent Income Tax No.	
14	Last Income Tax Clearance (Attach Photocopy)	
15	Name of Bankers & Branch with full address	
16	Type of Account & A/C No.	
17	Name (s) of Authorized Representatives (s) Note: Power of Attorney signed by the Director(s)/ Partners / Proprietor in favour of the authorized Person signing the tender documents must be enclosed.	



**ENGINEERING, PROCUREMENT AND CONSTRUCTION MANAGEMENT (EPCM) SERVICES FOR
INSTALLATION OF LPG AMINE ABSORBER SYSTEM IN PFCC UNIT AT MRPL, MANGALURU**

18	Type of job in which engaged as independent manufacturer. contractor	
19	Maximum value of the Job the Contractor/ manufacturer is capable of Handling per year. (Furnish details of your Financial standing together with the Bank References and necessary Solvency certificate From their banker (Nationalized) as per Bank's Format).	
20	Were you associated with MRPL in any Other contract in the past	
21	Are you currently having any contract with MRPL	
22	Are you on the approved list of other Oil Cos/ Public Sector Undertakings / govt. Dept. Etc. If so, furnish true copies of Certificates certifying your performance	
23	Please confirm that you have qualified/ trained / experienced staff on your payroll to handle this job	
24	Furnish Audited Balance sheet for last 3 Years ending previous financial year	
25	Details of technical collaboration. Please provide Documentary support (Xerox copies) if any and the brief experience of the parties	
26	Confirmed that Bank Guarantee for acceptance of the Security Deposit as per tender will be provided	
27	Brief Description of the job methodology/Quality Assurance :	
28	Details of Testing methods and equipment's that will be made available	
29	Details of your Past Experience in the country (India) in this nature of job.	
30	Whether the bidder is put on Holiday list of any of the PSU. (If sought later, an affidavit to be produced later to MRPL.)	



**ENGINEERING, PROCUREMENT AND CONSTRUCTION MANAGEMENT (EPCM) SERVICES FOR
INSTALLATION OF LPG AMINE ABSORBER SYSTEM IN PFCC UNIT AT MRPL, MANGALURU**

Bidder shall provide details in the below format, of at least one Authorised Contact person in Bidder's organization with whom MRPL may correspond on the matter for seeking any clarifications:

1	<u>Primary Contact Details of the Bidder</u>	
	Name	
	Designation	
	Landline Nos.	
	Cell Phone nos.	
	Email IDs	
2	<u>Alternate Contact Details of the Bidder</u>	
	Name	
	Designation	
	Landline Nos.	
	Cell Phone nos.	
	Email IDs	

Note: The Bidder to fill up the above and enclose along with Technical Bid.

Authorized Signatory

(With Company Seal & Signature)



FORM-S

DECLARATION FOR LIQUIDATION/COURT RECEIVERSHIP

(ON LETTERHEAD OF BIDDER)

We confirm that we are not under Liquidation, Court Receivership or Similar Proceedings

For & on behalf of

Authorised signatory of Bidder



**ENGINEERING, PROCUREMENT AND CONSTRUCTION MANAGEMENT (EPCM) SERVICES FOR
INSTALLATION OF LPG AMINE ABSORBER SYSTEM IN PFCC UNIT AT MRPL, MANGALURU**

UNDERTAKING BY THE BIDDERS

(TO BE GIVEN ON BIDDER'S LETTER HEAD)

Tender No: _____

Name of the Work: _____

We _____ (Name of the Tenderer) hereby certify that we have fully read and thoroughly understood all the tender requirements and accept all terms and conditions of the tender including all corrigendum / addendum / clarification issued, if any. Our offer is in confirmation to all the terms and conditions of the tender including all corrigendum / addendum / clarification, if any and minutes of the pre-bid meeting. In the event our offer is found acceptable and contract is awarded to us, the complete tender document shall be considered for constitution of Contract Agreement.

We confirm that we have quoted the rates in the tender considering inter-alia the

- 1) Tender Document(s)
- 2) Scope of Work / Special Conditions of Contract
- 3) Safety Policy
- 4) Pre-bid meeting Minutes (if any)
- 5) SOR / Price bid format
- 6) Corrigendum / Addendum/ Clarification (if any)

Place :

Signature of Bidder :

Date :

Name of Signatory :

Note: This declaration should be signed by the Tenderer's authorised representative on Company Letterhead who is signing the Bid and Scanned copy to be uploaded.



**ENGINEERING, PROCUREMENT AND CONSTRUCTION MANAGEMENT (EPCM) SERVICES FOR
INSTALLATION OF LPG AMINE ABSORBER SYSTEM IN PFCC UNIT AT MRPL, MANGALURU**

FORM OF CONTRACT AND CONDITIONS OF CONTRACT

For

**ENGINEERING, PROCUREMENT AND CONSTRUCTION
MANAGEMENT (EPCM) SERVICES FOR INSTALLATION OF LPG
AMINE ABSORBER SYSTEM IN PFCC UNIT AT MRPL,
MANGALURU.**

Tender No.: 3200000464



**ENGINEERING, PROCUREMENT AND CONSTRUCTION MANAGEMENT (EPCM) SERVICES FOR
INSTALLATION OF LPG AMINE ABSORBER SYSTEM IN PFCC UNIT AT MRPL, MANGALURU**

FORM OF CONTRACT AND CONDITIONS OF CONTRACT

INDEX OF ARTICLES

ARTICLE	TITLE
Article 1	DEFINITIONS
Article 2	EFFECTIVE DATE OF CONTRACT
Article 3	SCOPE OF SERVICES
Article 4	REMUNERATION AND CONTRACT PRICE
Article 5	CONTRACT PERIOD
Article 6	NOTICES
Article 7	ENTIRE CONTRACT
Article 8	JURISDICTION & APPLICABLE LAW
Article 9	INSURANCE
Article 10	INDEMNITY
Article 11	SECRECY
Article 12	FORCE MAJEURE
Article 13	WAIVER
Article 14	ARBITRATION & CONCILIATION
Article 15	SUSPENSION,CANCELLATION, TERMINATION & RISK PURCHASE
Article 16	PATENTS
Article 17	ASSIGNABILITY
Article 18	CESSATION OF CONSULTANT SERVICES
Article 19	MECHANICAL COMPLETION
Article 20	CHANGES AND ADDITIONS IN CONSULTANT'S SCOPE OF SERVICES
Article 21	CONTRACT PERFORMANCE BANK GUARANTEE /SECURITY DEPOSIT (SD)
Article 22	AMENDMENT
Article 23	LIMITATION OF LIABILITY& EXCLUSION OF GOVT OF INDIA'S LIABILITY
Article 24	MISCELLANEOUS



**ENGINEERING, PROCUREMENT AND CONSTRUCTION MANAGEMENT (EPCM) SERVICES FOR
INSTALLATION OF LPG AMINE ABSORBER SYSTEM IN PFCC UNIT AT MRPL, MANGALURU**

FORM OF CONTRACT

THIS CONTRACT made on the ---- day of 2020

BY AND BETWEEN

Mangalore Refinery and Petrochemicals Ltd. a Company having its registered office at Mudapadav, Kuthethoor, P.O. Via Katipalla, Mangalore – 575 030, (hereinafter referred to as "MRPL" or "OWNER") which term shall, unless repugnant to the context or meaning thereof, be deemed to include its successors and permitted assigns, of one part,

AND

Consultant, a Company having its registered office at (Hereinafter referred to as CONSULTANT) which expression shall, include its successors and permitted assigns, of the other part,

MRPL AND CONSULTANT also sometime referred individually as "Party" and collectively as "Parties"

WITNESSETH THAT

WHEREAS MRPL intends to engage Consultant to provide Consultancy for EPCM services for the systems specified

Hereinafter referred to and specified in this CONTRACT as "SERVICES".

AND WHEREAS CONSULTANT agrees to perform such SERVICES and submitted proposal thereof, and after discussion MRPL and CONSULTANT have finally agreed to the terms and conditions for the performance of the said SERVICES as detailed herein.

NOW THEREFORE, in consideration of the premises and the covenants set forth in this CONTRACT, MRPL and CONSULTANT mutually agree and confirm the agreement detailed herein and witnesseth as follows:

**ARTICLE-1
(DEFINITIONS)**

For the purpose of this CONTRACT, unless otherwise specified or repugnant to the subject or context, the following terms shall be deemed to have the following meaning:

- 1.1 "AUTHORISED REPRESENTATIVE" shall mean the representatives of "MRPL" and/or 'CONSULTANT' as the case may be who are duly empowered and authorized by their representative organizations to act for and on behalf.
- 1.2 "BATTERY LIMIT" shall mean the demarcated area within which all the Units and Facilities under Consultant's scope as detailed in the Contract are being installed for Project.
- 1.3 "CONTRACT" shall mean this contract including Tender documents as given in Instructions to Bidders, Acceptance Award of Tender, further Amendments / Corrigendum, all Exhibits hereto, all documents herein attached and amendments which the PARTIES may hereafter agree in writing to be made to this CONTRACT.
- 1.4 "CONSULTANT" shall mean successful bidder.



**ENGINEERING, PROCUREMENT AND CONSTRUCTION MANAGEMENT (EPCM) SERVICES FOR
INSTALLATION OF LPG AMINE ABSORBER SYSTEM IN PFCC UNIT AT MRPL, MANGALURU**

- “CONTRACTOR” shall mean any third party whose services are obtained by MRPL for supply, execution and/or erection of units/ facilities covered under Consultant’s Scope of Services.
- 1.5 “DESIGN BASIS” shall mean requirements as agreed between MRPL and CONSULTANT for CONSULTANT’s Scope of Services.
- 1.6 “MECHANICAL COMPLETION” shall mean completion of PLANT as defined in the CONTRACT.
- 1.7 OWNER/MRPL shall mean, Mangalore Refinery & Petrochemicals Ltd a Company incorporated under Companies Act. 1956 and having its registered office at Mangalore”.
- 1.8 “PROJECT” shall mean the Engineering, Procurement and Construction Management (EPCM) Services for Installation of LPG Amine Absorber System in PFCC Unit at MRPL, Mangaluru for which CONSULTANT shall provide SERVICES under this CONTRACT.
- 1.9 “PARTIES” shall mean MRPL and CONSULTANT, each one individually referred to as PARTY.
- 1.10 “PLANT” shall mean the systems and facilities associated with the PROJECT for which CONSULTANT is to provide SERVICES under this contract.
- 1.11 “PROCESS LICENSOR” shall mean the agency carrying out the job of preparation of Process packages for the licensed units.
- 1.12 “PROJECT DESCRIPTION” shall mean all necessary work and SERVICES to be performed by CONSULTANT as described in Exhibit-1.
- 1.13 “Sub-consultant”-any person or entity to whom/which the Consultant subcontracts any part of the Services.
- 1.14 “SCOPE OF WORK” /”WORKS” shall mean the SERVICES to be performed by CONSULTANT as set forth in Exhibit-2.
- 1.15 “SPECIFICATIONS” shall mean and include detailed description, statements to technical data, performance characteristics, and standards (Indian as well as International) as applicable and as specified in the CONTRACT.
- 1.16 “WARRANTIES & GUARANTEES” shall mean the warranties described in Exhibit- 7

ARTICLE 2

(EFFECTIVE DATE OF CONTRACT)

- 2.1 On signing by MRPL and CONSULTANT, this CONTRACT shall be deemed to have come into force with effect from.....20....

ARTICLE 3

(SCOPE OF SERVICES)

- 3.1 CONSULTANT shall perform the SERVICES as herein specified as Exhibit-2 for the Project description specified as Exhibit-1 and within the schedule of Commissioning as defined in Exhibit-3 from the “zero date of contract” as specified in this CONTRACT (Exhibit-3). OWNER’S obligations shall be defined in Exhibit-5.



**ENGINEERING, PROCUREMENT AND CONSTRUCTION MANAGEMENT (EPCM) SERVICES FOR
INSTALLATION OF LPG AMINE ABSORBER SYSTEM IN PFCC UNIT AT MRPL, MANGALURU**

**ARTICLE-4
(REMUNERATION AND CONTRACT PRICE)**

- 4.1 MRPL shall, in consideration of the SERVICES performed including grant of rights as herein stipulated, pay to CONSULTANT remuneration as provided in Exhibit-4, 9 & 11 and as per the payment terms specified therein.
- 4.2 The total lump sum amount payable by MRPL to CONSULTANT shall constitute the Contract Price as described in LOA No.....

**ARTICLE 5
(CONTRACT PERIOD)**

- 5.1 On signing by MRPL and CONSULTANT, this contract shall be deemed to have come into force from the effective date of contract and remain in force up to such period as may be stipulated in the CONTRACT and where no such period has been stipulated, on cessation of CONSULTANT's responsibilities and payments by MRPL to CONSULTANT of all admitted amounts due and payable under the CONTRACT.

**ARTICLE 6
(NOTICES)**

- 6.1 The official address and facsimile numbers of the PARTIES for the purposes of this contract are as follows but either PARTY may change the same by notice in writing to the other PARTY. The address of the PARTIES hereto are:
Consultant:
MRPL:
All notices hereunder shall be in writing and shall be sufficient if delivered or sent by registered mail, facsimile, airmail, to the PARTY entitled thereto at the above address.
- 6.2 Date of notice of instruction shall be the day on which said notice or instruction is received.

**ARTICLE – 7
(ENTIRE CONTRACT)**

- 7.1 The contract documents mentioned in this contract hereof embody the entire contract between the PARTIES hereto, and the PARTIES declare that in entering this contract they do not rely upon any previous representation, whether expressed or implied and whether oral or written, or any inducement, understanding or agreement of any kind not included within the contract documents, and unless herein incorporated at prior negotiations, representations, and/or agreements and understandings relating to the subject matter are hereby treated as null and void.



**ARTICLE – 8
(JURISDICTION & APPLICABLE LAW)**

- 8.1 Notwithstanding any other Court or Courts having jurisdiction to decide the question(s) forming the subject matter of the reference, any/all actions and proceeding arising out of or relative to the CONTRACT (including any arbitration in terms thereof) shall lie only in the court of Competent Civil Jurisdiction in this behalf at Mangalore (India) and only the said Court(s) shall have jurisdiction to entertain and try any such action(s) and/or proceeding(s) to the exclusion of all other Courts.
- 8.2 This CONTRACT shall be governed by the laws of India.

**ARTICLE –9
(INSURANCE)**

- 9.1 Owner shall at its own cost and expense take out from a suitable insurance company and maintain the following insurances, which shall be
Erection All risks Insurance (EAR) or Contractor's All Risks Insurance (CAR)

The OWNER at his own cost has taken an "all risk" type insurance policy. These policies apply only to insurance risks at site and to no other location. The CONSULTANT shall be solely liable in the event of his and/or his permitted SUB CONSULTANT's having caused any loss or damage of any nature arising out of or in connection with the execution of the WORK not covered under those policies and shall indemnify the OWNER and /or his representative in respect of any claim in respect of any such loss or damage. The CONSULTANT shall make himself fully familiar with the terms of the said policies and take such additional insurance as he may deem necessary at his own cost.

During the performance of SERVICES hereunder, CONSULTANT maintain insurance as listed below:

CONSULTANT FURNISHED INSURANCE:

Insurance Cover for Workmen:

The consultant shall obtain adequate Insurance Policy in respect of his workmen to be engaged for the work compulsorily towards compensations as admissible under the Workmen's Compensation Act 1923, and Rules framed there under upon death/disablement of a worker and the same has to be produced to the concerned in charge of Administration Section before start of the work.

All workers whose salary is more than **Rs 21,000/-** per month (Prevailing rate as per the act) need not to be covered by ESI. However, consultant to take insurance policy to cover the risk towards temporary disablement and permanent disablement for the workmen.

- 9.2 CONSULTANT shall at his cost and expense take out from a suitable insurance company acceptable to owner and maintain for the entire period until ACCEPTANCE OF WORKS or until such time thereafter as the CONSULTANT may consider appropriate the following insurances.

1. Workmen's Compensation Insurance (WCI)



**ENGINEERING, PROCUREMENT AND CONSTRUCTION MANAGEMENT (EPCM) SERVICES FOR
INSTALLATION OF LPG AMINE ABSORBER SYSTEM IN PFCC UNIT AT MRPL, MANGALURU**

This insurance shall confirm to and satisfy all the requirements of the applicable laws and regulations of the country, state territory or province having jurisdiction over the CONSULTANT's employees engaged in the WORKS.

2. Employer's Liability Insurance (ELI)

The insurance shall cover the liability of the CONSULTANT as employer, for compensation beyond the coverage of the Workmen's Compensation Insurance for bodily injury to or loss of life the CONSULTANT's employees while engaged in the WORKS.

3. Third Party Liability Insurance (TPL)

This insurance shall cover legal liability for bodily injury to loss of life of and/or damage to and loss of properties of the third person party arising out of the performance by the CONSULTANT of the works.

4. Automobile Liability Insurance (ALI) (If applicable)

This insurance shall cover all the CONSULTANT 's liabilities in connection with use by the CONSULTANT for the WORKS of any mobile equipment and automobile and when used which are owned, non-owned hired and otherwise placed under the CONSULTANT 's administration and control, for bodily injury to loss of life of and/or property damage of any person or party.

5. Movable All Risks Insurance (MRI) (If applicable)

This insurance shall cover the damage to and/or loss of the CONSTRUCTION EQUIPMENT including watercraft and aircraft and further including the CONSULTANT 's TEMPORARY WORKS, owned, non-owned, hired or otherwise placed under the CONSULTANT 's administration and control with the full replacement value coverage for each and every occurrence.

6. Other Insurance

Other insurance which shall be necessary or which the CONSULTANT deems necessary for proper performance of the SERVICES e.g.

- Overseas (and/or Domestic) Travellers' accident Insurance.
- Burglary Insurance
- All Risks marine cargo Insurance for the CONSULTANT 's equipment, tools and machinery, and for equipment and materials that the CONSULTANT 's TEMPORARY WORKS and that the CONSULTANT under the CONTRACT may supply for the WORKS and/or the PERMANENT WORK and
- Fidelity Guarantee Insurance

The CONSULTANT agree that the provisions of this Clause shall to the extent as appropriate, be apply all the contracts that may for the WORKS/SERVICE be entered into by and between the CONSULTANT and the respective SUBCONSULTANT s and unless the CONSULTANT furnished insurance called for by the CONTRACT are good also for the SUBCONSULTANT s their properties and/or their liabilities in connection



**ENGINEERING, PROCUREMENT AND CONSTRUCTION MANAGEMENT (EPCM) SERVICES FOR
INSTALLATION OF LPG AMINE ABSORBER SYSTEM IN PFCC UNIT AT MRPL, MANGALURU**

with the WORKS/ SERVICE the CONSULTANT shall include in such contracts as aforementioned the requirements for insurance conforming to this clause.

Inclusion of such insurance requirements in such contracts as aforementioned however, shall not release the CONSULTANT from any of his responsibilities and liabilities under the CONTRACT.

The Consultant in addition is responsible to procure any other insurance as mandated under any applicable law

**ARTICLE – 10
(INDEMNITY)**

- 10.1 CONSULTANT shall hold harmless and indemnify MRPL against any claims or liability because of personal injury including death of any employee of CONSULTANT and arising out of or in consequence of the performance of this contract, howsoever caused.
- 10.2 MRPL shall not be responsible for any loss or damage to property of any kind belonging to CONSULTANT or its employees, servants or agents.
- 10.3 MRPL shall hold harmless and indemnify CONSULTANT against any claim or liability arising in respect of:
- Injury to or death of MRPL's employees, agents and contractors or any other persons excluding only employees of CONSULTANT, save that are caused due to voluntary contribution and or negligence of the CONSULTANT; and
 - Loss of or damages to the property of MRPL, MRPL's employees, agents and contractors or any other person except those belonging to CONSULTANT or its employees, save that are caused due to voluntary contribution and or negligence of the CONSULTANT.

**ARTICLE – 11
(SECURITY)**

- 11.1 MRPL shall not disclose to any third PARTY, any Technical information, process data, design, drawings, plans, specifications, etc. received from CONSULTANT at any time either in whole or in part, shall use all reasonable efforts to preserve the secrecy of the above Technical information and shall not use the same for any purpose other than the construction, maintenance and operation of the resultant PLANT. However, the disclosure of such Technical Information to Government of India or statutory authorities of Government of India shall not be deemed to be a violation of the Secrecy understanding contained herein.
- 11.2 The above undertakings shall not, however, extend to any such technical information which:
- Is in possession of MRPL prior to receipt of the same, directly or indirectly from CONSULTANT.
 - Is received by MRPL without any secrecy obligation.
 - Is or has become part of the public knowledge through no fault of MRPL.
- 11.3 CONSULTANT shall likewise have secrecy obligations in respect of confidential information provided by MRPL.



ARTICLE – 12

(FORCE MAJEURE)

Circumstances leading to force majeure;

- a) act of terrorism;
- b) riot, war, invasion, act of foreign enemies, hostilities (whether war be declared or not), civil war, rebellion, revolution, insurrection of military or usurped power;
- c) ionising radiation or contamination, radio activity from any nuclear fuel or from any nuclear waste from the combustion of nuclear fuel, radioactive toxic explosive or other hazardous properties of any explosive assembly or nuclear component;
- d) epidemics, earthquakes, flood, fire, hurricanes, typhoons or other physical natural disaster, but excluding weather conditions regardless of severity; and
- e) freight embargoes, strikes at national or state-wide level or industrial disputes at a national or state-wide level in any country where Works are performed, and which affect an essential portion of the Works but excluding any industrial dispute which is specific to the performance of the Works or the Contract.

For the avoidance of doubt, inclement weather, third party breach, delay in supply of materials (other than due to a nationwide transporters' strike) or commercial hardship shall not constitute a Force Majeure event.

12.1 Notification of Force Majeure;

Consultant shall notify within [10(ten)] days of becoming aware of or the date it ought to have become aware of the occurrence of an event of Force Majeure giving full particulars of the event of Force Majeure and the reasons for the event of Force Majeure preventing the Affected Party from, or delaying the Affected Party in performing its obligations under the Contract.

12.2 Right of either party to terminate;

If an event of Force Majeure occurs and its effect continues for a period of 180 (one hundred eighty days) or more in a continuous period of 365 (three hundred sixty five) days after notice has been given under this clause, either Party may terminate the Contract by issuing a written notice of 30 (thirty) days to the other Party.

12.3 Payment in case of termination due to Force Majeure;

The Contract Price attributable to the Works performed as at the date of the commencement of the relevant event of Force Majeure.

The Consultant has no entitlement and Owner has no liability for:

- a) any costs, losses, expenses, damages or the payment of any part of the Contract Price during an event of Force Majeure; and
 - b) any delay costs in any way incurred by the Consultant due to an event of Force Majeure.
- Time extension for such cases will be worked out appropriately.



**ARTICLE – 13
(WAIVER)**

13.1 No failure or delay by either PARTY in enforcing any right, remedy, obligations or liability in terms of the CONTRACT shall be deemed to be a waiver of such right, remedy, obligations or liability, by the said PARTY and notwithstanding such failure or delay, the PARTY shall be entitled at any time to enforce such right, remedy, obligation or liability as the case may be.

**ARTICLE – 14
(ARBITRATION & CONCILIATION)**

Parties hereby agree as under:

If any difference or dispute (hereinafter referred as "Dispute") under the Contract arises, the party shall give a 60 days written notice ("**Dispute Notice**") to the identified officer of the other party mentioned in the Contract giving details of the Dispute. The Parties shall use all reasonable endeavours to resolve the Dispute mutually and amicably. All efforts by either party within these 60 days Dispute Notice Period shall be kept confidential by both the parties under Section 75 of the Arbitration and Conciliation Act, 1996. Parties shall not rely upon any views expressed or suggestions made by the other party, admissions made by the other party or the fact that the other party had indicated his willingness to enter into a settlement as evidence in any Forum / arbitration / court proceeding.

If Parties are unable to resolve the Dispute amicably within 60 days of receipt of the Dispute Notice, then after expiry of the 60 days' Dispute notice period, the aggrieved Party can refer the Dispute to conciliation and / or arbitration subject to terms and conditions contained herein below:

- 1) Parties further agree that following matters shall not be referred to Conciliation or Arbitration:
 - i) Any claim, difference or dispute relating to, connected with or arising out of MRPL decision to initiate any proceedings for suspension or banning, or decision to suspend or to ban business dealings with the Bidder / Consultant and/or with any other person involved or connected or dealing with bid / contract / bidder / Consultant .
 - ii) Any claim, difference or dispute relating to, connected with or arising out of MRPL decision under the provisions of Integrity Pact executed between MRPL and the Bidder / Consultant.
- 2) Part-I: Conciliation (Not applicable in contracts valuing less than Rs. 10 lakhs)
- 3) Part-II: Arbitration (Not applicable in contracts valuing less than ₹ 5 lakhs) If the parties are not able to resolve the dispute through OEC or do not opt for conciliation through OEC, the party may invoke arbitration clause as provided in the contract.

PART - I : CONCILIATION: Resolution of disputes through conciliation by OEC (Not applicable in Contracts valuing less than Rs.10 lakhs):

If any dispute, difference, question or disagreement arises between the parties hereto or their respective representatives or assignees, in connection with construction, meaning, operation, effect, interpretation of the contract or breach thereof which parties are unable to settle mutually, the same may first be referred to conciliation through Outside Expert Committee ("OEC") to be constituted by MD, MRPL as provided hereunder:



**ENGINEERING, PROCUREMENT AND CONSTRUCTION MANAGEMENT (EPCM) SERVICES FOR
INSTALLATION OF LPG AMINE ABSORBER SYSTEM IN PFCC UNIT AT MRPL, MANGALURU**

Submission of proposal for OEC

1. Conciliation through OEC will be resorted in all cases involving disputed amount up to ` 250 crores only. The disputed amount will be calculated by considering the amount of claim and counter-claim of the parties.
2. Claimant shall give a 30 days' notice for conciliation. In cases where the consultant is claimant then the notice shall be given to the concerned MRPL office as per the contract, clearly bringing out the points of dispute and the amount claimed with documents in support of the claim and the party concerned shall not raise any new issue thereafter.

Constitution of OEC

3. MD, MRPL will have the sole discretion to constitute OEC. OEC will be formed from the panel of experts maintained by MRPL and will normally comprise of three members, one member from each category i.e., Technical, Finance, Commercial and Legal. However, there will be a single member OEC for disputes involving a claim and counter claim (if any) upto ` 1 crore.
4. MD, MRPL will have authority to reconstitute an OEC to fill any vacancy or if any OEC member is not available to attend the OEC Meetings.
5. Upon constitution of the OEC, Head-Legal will issue the appointment letters to OEC members and inform same to the parties concerned.
6. The OEC members shall give a declaration of independence and impartiality (in the format at **Annexure A1**) to both the parties before the commencement of the OEC proceedings.

Proceedings before OEC

7. The claimant shall submit its statement of claims to OEC members, and to the party(s) prescribed in the appointment letter within 30 days of the issue of the appointment letter. The claims shall be raised as per the format at **Annexure A2**.
8. The respondent shall file its reply and counter claim (if any) within 30 days of the receipt of the statement of claims. (As per aforesaid format at **Annexure A2**).
9. Parties may file their rejoinder/additional documents, if any in support of their claim/counter claim within next 15 days. No documents shall be allowed thereafter.
10. OEC will commence its meetings only after completion of the pleadings.
11. In case of 3 members OEC, 2 members will constitute a valid quorum and the meeting can take place to proceed in the matter after seeking consent from the member who is not available. If necessary video conferencing may be arranged. However, OEC Recommendations will be signed by all Members. Further, efforts must be made for unanimous recommendations.
12. The parties shall be represented by their in-house employees/executives. No party shall be allowed to bring any advocate or outside consultant/advisor/agent to contest on their behalf. Ex-officers of MRPL who have handled the dispute matter in any capacity are not allowed to attend and present the case before OEC on behalf of Consultant . However, ex-employees of parties may represent their respective organizations.



**ENGINEERING, PROCUREMENT AND CONSTRUCTION MANAGEMENT (EPCM) SERVICES FOR
INSTALLATION OF LPG AMINE ABSORBER SYSTEM IN PFCC UNIT AT MRPL, MANGALURU**

13. Solicitation or any attempt to bring influence of any kind on either OEC Members or MRPL is completely prohibited in conciliation proceedings and MRPL reserves the absolute right to close the conciliation proceedings at its sole discretion if it apprehends any kind of such attempt made by the Consultant or its representatives.
14. Parties agree to rely only upon documentary evidence in support of their claims and not to bring any oral evidence in the OEC proceedings.
15. OEC will give full opportunity of hearing to the parties before giving its recommendations.
16. OEC will conclude its proceedings in maximum 10 meetings, and give its recommendations within 90 days of its first meeting. OEC will give its recommendations to both the parties recommending possible terms of settlement MD, MRPL may extend the time/ number of meetings, in exceptional cases, if OEC requests for the same with sufficient reasons.
17. OEC members will be paid fees (plus applicable tax) and provided facilities as detailed in clause 29 below, subject to revision by MRPL from time to time and subject to Government guidelines on austerity measures, if any. All the expenditure incurred in the OEC proceedings shall be shared by the parties in equal proportion. The parties shall maintain account of expenditure and present to the other for the purpose of sharing on conclusion of the OEC proceedings.
18. Depending upon the location of the OEC members and the parties, the venue of the OEC meeting shall be either Delhi /Mangaluru / Bengaluru or any other location whichever is most economical from the point of view of travel and stay etc.
19. Parties shall not claim any interest on claims/counterclaims from the date of notice invoking conciliation till execution of settlement agreement, if so arrived at. In case, parties are unable to reach a settlement, no interest shall be claimed by either party for the period from the date of notice invoking conciliation till the date of OEC recommendations and 30 days thereafter in any further proceeding.
20. Legally, parties are under no obligation to refer a dispute to conciliation or continue with conciliation proceedings. Parties are free to terminate the conciliation proceedings at any stage as provided under the Arbitration and Conciliation Act, 1996 and subsequent amendments or re-enactment thereof.

Actions after OEC Recommendations

21. The recommendations of OEC are non-binding and the parties may decide to accept or not to accept the same. Parties are at liberty to accept the OEC recommendation with any modification they may deem fit.
22. The consultant shall give its response to MRPL within 7 days of receiving OEC Recommendation.
23. If the recommendations are acceptable to the consultant partly or fully, MRPL will consider and take a decision on OEC recommendations. MRPL shall communicate its decision to the Consultant. If decision of MRPL is acceptable to the Consultant, a settlement agreement under Section 73 of the Arbitration and Conciliation Act, 1996 will be signed within 15 days of Consultant's acceptance and same shall be authenticated by all the OEC Members.



ENGINEERING, PROCUREMENT AND CONSTRUCTION MANAGEMENT (EPCM) SERVICES FOR INSTALLATION OF LPG AMINE ABSORBER SYSTEM IN PFCC UNIT AT MRPL, MANGALURU

24. The timelines mentioned in the above guidelines are with an objective to achieve expeditious conclusion of OEC proceedings. However, it does not mean that any action beyond the timelines will be invalid. However, the party concerned will make all efforts to complete the actions within the stipulated time.
25. Parties shall keep confidential matters relating to the conciliation proceedings including minutes of OEC meeting and Recommendations of OEC. Parties shall not rely upon them as evidence in any Forum/arbitration/court proceeding, whether or not such proceedings relate to the dispute that is the subject of the conciliation proceedings,
- Views expressed or suggestions made by the other party in respect of a possible settlement of the dispute.
 - Admissions made by the other party in the course of the OEC proceedings;
 - Proposals made by the OEC;
 - The fact that the other party had indicated his willingness to accept a proposal for settlement made by the OEC.
26. Confidentiality extends also to the settlement agreement, except where its disclosure is necessary for purposes of implementation and enforcement. This stipulation will not apply to disclosure made by MRPL to Govt. of India, if required.
27. Subject to terms and conditions contained in the above paras, the provisions of the Part III of Arbitration and Conciliation Act, 1996 shall be acceptable to the conciliation proceedings and the parties and the OEC members shall be bound by the same.
28. If the parties are not able to resolve the dispute through OEC or do not opt for conciliation through OEC, the party may invoke arbitration clause as provided in the contract.
29. **Fees and Facility to the OEC Members :**

OEC members shall be entitled for the following fees plus applicable taxes per member and facilities:

Sl. No	Fees/Facility	Entitlement	To be paid by
1.	Fees	Rs 20,000/- per meeting subject to maximum of Rs. 2,00,000/-* for the whole case. In addition, one OEC member chosen by OEC shall be paid an additional amount of Rs 10,000/- towards secretarial expenses in writing minutes/ OEC Recommendations.	Consultant
2.	Fee for attending meeting/s to authenticate the settlement agreement.	Rs 10,000/-	Consultant
3.	Transportation in the city of meeting	Car as per entitlement or Rs 2,000/- per day	Consultant
4.	Venue of the meeting	MRPL conference rooms/Hotels	MRPL



ENGINEERING, PROCUREMENT AND CONSTRUCTION MANAGEMENT (EPCM) SERVICES FOR INSTALLATION OF LPG AMINE ABSORBER SYSTEM IN PFCC UNIT AT MRPL, MANGALURU

Facilities to be provided to the out-stationed member

5.	Travel from the city of residence to the city of meeting	Business class air tickets/first class train tickets/ car/ reimbursement of actual fare. However, entitlement of air travel by Business class shall be subject to austerity measures, if any, ordered by Govt. of India.	Consultant
6.	Transport to and fro airport / railway station in the city of residence	Car as per entitlement or Rs3,000/-	Consultant
7.	Stay for out stationed members	5 Star Hotel	MRPL
8.	Transport in the city of meeting	Car as per entitlement or Rs 2,000/- per day	Consultant

* except in exceptional cases, where the no. of meetings may extend beyond 10.

PART – II: ARBITRATION (Applicable in case of supply orders/Contracts with firms, other than Public Sector Enterprises) (Not applicable in contracts valuing less than ₹ 5 lakhs)

Except as otherwise provided elsewhere in the contract, if any dispute, difference, question or disagreement arises between the parties hereto or their respective representatives or assignees, in connection with construction, meaning, operation, effect, interpretation of the contract or breach thereof which parties are unable to settle mutually or through conciliation, the same shall be referred to Arbitration as provided hereunder:

1. There shall be no arbitration for disputes involving claims upto ₹ 25 lakhs and more than ₹ 100 crores. The disputed amount will be calculated by considering the amount of claim and counter-claim of the parties. Unresolved disputes involving claims above ₹ 100 crores shall be adjudicated under the Commercial Courts, Commercial Division and Commercial Appellate Division of High Courts Act, 2015.
2. A party wishing to commence arbitration proceeding shall invoke Arbitration Clause by giving 60 days' notice to the other party. The notice invoking arbitration shall specify all the points of disputes with details of the amount claimed to be referred to arbitration at the time of invocation of arbitration and not thereafter. If the claim is in foreign currency, the claimant shall indicate its value in Indian Rupee for the purpose of constitution of the arbitral tribunal.
3. Arbitration can be invoked by giving Invocation Notice only after expiry of the 60 days' period as per Dispute Notice.
4. For a dispute involving claims above ₹ 25 lacs and upto ₹ 5 crores, in case other party is Claimant, MRPL will forward a list containing names of five jurists to the other party for selecting one from the list who will be appointed as sole arbitrator by MRPL. In case MRPL itself is the Claimant, it shall appoint the Sole Arbitrator by invoking the Arbitration clause and inform the Consultant. Such dispute shall be resolved on fast track procedure specified in Section 29B of the Arbitration and Conciliation Act, 1996.



ENGINEERING, PROCUREMENT AND CONSTRUCTION MANAGEMENT (EPCM) SERVICES FOR INSTALLATION OF LPG AMINE ABSORBER SYSTEM IN PFCC UNIT AT MRPL, MANGALURU

5. For a dispute involving claims above ₹ 5 crores and upto ₹ 100 crore, the claimant shall appoint an Arbitrator and communicate the same to the other Party in the Invocation Notice itself along with the copy of disclosure made by nominated Arbitrator in the form specified in Sixth Schedule of the Arbitration & Conciliation Act, 1996. For the purpose of Section 21, the Arbitration Proceeding shall commence only upon date of receipt of Invocation Notice complete in all respects mentioned above. The other Party shall then appoint the second Arbitrator within 15 days from the date of receipt of written notice. The two Arbitrators appointed by the Parties shall appoint the third Arbitrator, within 30 days, who shall be the Presiding Arbitrator. The parties agree that they shall appoint only those persons as arbitrators who accept the conditions of this arbitration clause. No person shall be appointed as arbitrator or presiding arbitrator who does not accept the conditions of this arbitration clause.
6. For the purpose of appointment of Arbitrator(s), claims amount shall be computed excluding claim for interest, if any.
7. The parties agree that they shall appoint only those persons as arbitrators who accept the conditions of this arbitration clause. No person shall be appointed as arbitrator or presiding arbitrator who does not accept the conditions of this arbitration clause.
8. Parties agree that there will be no objection if the Arbitrator appointed holds equity shares of MRPL and/or is a retired officer of MRPL / any PSU. However, neither party shall appoint its serving employee as arbitrator and shall have been retired before 3 years on the date of commencement of the Arbitration.
9. If any of the Arbitrators so appointed dies, resigns, becomes incapacitated or withdraws for any reason from the proceedings, it shall be lawful for the concerned party/arbitrators to appoint another person in his place in the same manner as aforesaid. Such person shall proceed with the reference from the stage where his predecessor had left if both parties consent for the same; otherwise, he shall proceed de novo.
10. Parties agree that neither party shall be entitled for any pre-reference or pendente-lite interest on its claims, i.e. date of cause of action till date of Award by Arbitral Tribunal. Parties agree that claim for any such interest shall not be considered and shall be void. The Arbitrator / Tribunal shall have no right to award pre-reference or pendente-lite interest in the matter.
11. The arbitral tribunal shall make and publish the award within time stipulated as under:

Amount of Claims and Counter Claims (excluding interest)	Period for making and publishing of the award (counted from the date of first meeting of the arbitrators):
Up to Rs. 5 Crore	Within 8 months
Above Rs. 5 Crore	Within 12 months

The above time limit can be extended by the arbitrator, for reasons to be recorded in writing, with the consent of the parties.



**ENGINEERING, PROCUREMENT AND CONSTRUCTION MANAGEMENT (EPCM) SERVICES FOR
INSTALLATION OF LPG AMINE ABSORBER SYSTEM IN PFCC UNIT AT MRPL, MANGALURU**

12. The fees payable to each Arbitrator shall be as per rules framed by the High Court in whose territorial jurisdiction as per contract and seat of arbitration is situated. In case no rules have been framed, the fees prescribed may be as per Fourth Schedule of the Arbitration and Conciliation Act, 1996. However, Arbitrator may fix their fees keeping the aforesaid schedule as guiding factor.
13. The parties may, after invocation of dispute, agree for sharing the cost of Arbitration equally on 50:50 basis.
14. If after commencement of the Arbitration proceedings, the parties agree to settle the dispute mutually or refer the dispute to conciliation, the arbitrators shall put the proceedings in abeyance until such period as requested by the parties. Where the proceedings are put in abeyance or terminated on account of mutual settlement of dispute by the parties, the fees payable to the arbitrators shall be determined as under:
 - (i) 20 % of the fees if the claimant has not submitted statement of claim.
 - (ii) 40 % of the fees if the pleadings are complete.
 - (iii) 60% of the fees if the hearing has commenced.
 - (iv) 80% of the fees if the hearing is concluded but the award is yet to be passed
15. Each party shall pay its share of arbitrator's fees in stages as under:
 - (i) 20% of the fees on filing of reply to the statement of claims.
 - (ii) 40% of the fees on completion of pleadings.
 - (iii) 20% of the fees on conclusion of the final hearing.
 - (iv) 20% at the time when award is given to the parties.
16. Each party shall be responsible to make arrangements for the travel and stay etc of the arbitrator appointed by it. Claimant shall also be responsible for making arrangements for travel / stay arrangements for the Presiding Arbitrator and the expenses incurred shall be shared equally by the parties. In case of sole arbitrator, MRPL shall make all necessary arrangements for his travel stay and the expenses incurred shall be shared equally by the parties.
17. The Arbitration shall be held at the place from where the contract has been awarded. However, parties to the contract can agree for a different place for the convenience of all concerned.
18. The Arbitrator(s) shall give reasoned and speaking award and it shall be final and binding on the parties.
19. Subject to aforesaid, provisions of the Arbitration and Conciliation Act, 1996 and any statutory modification or re-enactment thereof shall apply to the arbitration proceedings under this clause.
20. Insofar as practicable, the Parties shall continue to implement the terms of the Contract notwithstanding the initiation of Arbitration proceedings.



**ENGINEERING, PROCUREMENT AND CONSTRUCTION MANAGEMENT (EPCM) SERVICES FOR
INSTALLATION OF LPG AMINE ABSORBER SYSTEM IN PFCC UNIT AT MRPL, MANGALURU**

**Arbitration Clause applicable in case of Purchase Orders/ Contracts on Public Sector
Enterprises**

Ref: No.4 (1) /2011-DPE (PMA)-GL, Government of India, Department of Public Enterprises. Dated 12th June 2013

In the event of any dispute or difference relating to, arising from or connected with the CONTRACT, such dispute or difference shall be referred by either party to the arbitration of one of the Arbitrators in the Department of Public Enterprises, to be nominated by the Secretary to the Government of India, In charge of the Bureau of Public Enterprises.

The Arbitration and Conciliation Act 1996 shall not be applicable to the Arbitration under this clause.

The award of the Arbitrator shall be binding upon the parties to the dispute, provided however; any party aggrieved by such award may make a further reference for setting aside or revision of the award to the Law Secretary, Deptt. of Legal Affairs, Ministry of Law and Justice,

Government of India. Upon such reference, the dispute shall be decided by the Law Secretary or the Special Secretary / Additional Secretary, whose decision shall bind the parties finally and conclusively.

The parties in the dispute will share equally the cost of the arbitration as intimated by the Arbitrator.

**Arbitrations with respect to Contracts between CPSEs & Government Departments /
Organizations:**

In the event of any dispute or difference relating to the interpretation and application of the provisions of commercial contract(s) between CPSEs / Port Trusts inter se and also between CPSEs and Government Departments / Organizations (excluding disputes concerning Railways, Income Tax, Customs and Excise Departments), such dispute or difference shall be taken up by either party for resolution through AMRCD as mentioned in DPE OM No 4(1)/2013-DPE (GM) fts-1835 DATED 22-05-2018.

Any amendment(s) made to the above shall be applicable as per Govt policies/guidelines issued from time to time.

Annexure A1

Declaration of independence and impartiality by OEC Member

To,

1. MRPL
2. Consultant

**Subject: Declaration of independence and impartiality by OEC Member in the dispute
between MRPLAnd.....under Contract No.....**

I, the undersigned, hereby accept to act as Member of the Expert Committee and conciliate in the disputes under reference between the parties above named.

I confirm that I am aware of the requirements of law particularly of the Arbitration and Conciliation Act, 1996, to act as a conciliator. I am able to act as conciliator and I am available to act as Member of the Expert Committee.



**ENGINEERING, PROCUREMENT AND CONSTRUCTION MANAGEMENT (EPCM) SERVICES FOR
INSTALLATION OF LPG AMINE ABSORBER SYSTEM IN PFCC UNIT AT MRPL, MANGALURU**

I hereby declare that I am independent of each of the parties and have no ownership interest in any part of the contract under reference or any financial interest in the said contract. I have no interest in the outcome of the dispute or its settlement.

I hereby affirm that I shall act with honesty, integrity, diligence, and will remain independent and impartial while discharging my duties as conciliator/OEC Member. I will disclose any interest or relationship with the parties or the subject matter which might compromise in any manner my ability or capacity to remain impartial and independent in the matter.

The fees and other facilities offered to me and the terms and conditions contained in the appoint letter and guidelines issued by MRPL are acceptable to me. I will not demand for enhancement of the same.

(Signature)

Name:

Address:

Phone:

Email:

Date:

Annexure - A2

STATEMENT OF CLAIM(S)/COUNTERCLAIM(S)

1. Chronology of the dispute
2. Brief of the contract
3. Brief history of the dispute:
4. Issues:
5. Details of claim(s)/Counter Claim(s):

Sl. No.	Description of claim(s)/Counter Claim	Amount (in INR/USD)	Relevant contract Clause

6. Basis/Ground of claim(s)/counter claim(s) (along with relevant clause of contract)

Statement of claims may kindly be restricted to maximum limit of 20 pages. Relevant documents may be compiled and submitted along with the statement of claims. The statement of claims is to be submitted to all OEC members, to other party and to the office of Head Legal Services-MRPL, by post as well as mail.

Authorized Signatory of the Claimant

Place :

Contact No. :

Date :

Email :



ARTICLE – 15

(SUSPENSION, CANCELLATION, TERMINATION & RISK PURCHASE)

15.1 SUSPENSION OF WORKS :

- I. Subject to the provisions of this contract, the consultant shall, if ordered by giving not less than fourteen days written notice by the Engineer-In-Charge/OWNER or his representative, temporarily suspend the works or any part thereof for such written order, proceed with the work therein ordered to be suspended until, he shall have received a written order to proceed therewith. Consultant shall use every reasonable efforts to recommence Work with the least possible delay within fourteen days upon receipt of OWNER's notice to resume. The consultant shall not be entitled to claim compensation for any loss or damage sustained by him by reason of temporary suspension of the works aforesaid. An extension of time for completion, corresponding with the delay caused by any such suspension of the works as aforesaid will be granted to the consultant should he apply for the same provided that the suspension was not consequent to any default or failure on the part of the Consultant.
- II. In case of suspensions of entire work, ordered in writing by Engineer-In-Charge/OWNER, for a period of more than two months, the consultant shall have the option to terminate the contract.

15.2 CANCELLATION :

- I. MRPL reserves the right to cancel the Order or any part thereof and shall be entitled to rescind the contract wholly or in a written notice to the vendor at any time if:

The successful tenderer shall commit a breach of any of the conditions stipulated contract and fail to remedy such breach within four days of the receipt of the written notice from MRPL in this regard.

Upon

- i. The death or adjudication as insolvent of the successful tenderer, if he/she be an individual.
- ii. The liquidation, whether voluntary or passing of the effective resolution for winding up of the successful tenderer if it be a company.
- II. If any successful tenderer or any partner in the firm of the successful tenderer shall be convicted of any criminal offence.
- III. If a receiver is appointed of any property or assets of the successful tenderer.
- IV. If the work/ services are no more required by MRPL.

If the license issued to the successful tenderer by the relevant authorities for modification filling and storage of bitumen supplied by MRPL is cancelled or revoked.

If the successful tender deliberately contaminates or tempers with quality or product supplied by MRPL.

MRPL will be at liberty to short close the contract work order without assigning any reason whatsoever by giving a notice of 15 days.

Specified delivery schedule/ completion period is not adhered to beyond 3 months from due date unless specifically agreed by MRPL.



ENGINEERING, PROCUREMENT AND CONSTRUCTION MANAGEMENT (EPCM) SERVICES FOR INSTALLATION OF LPG AMINE ABSORBER SYSTEM IN PFCC UNIT AT MRPL, MANGALURU

Laid down specifications are not adhered to or when the performance of the contract is unsatisfactory.

Major contractual terms and conditions are violated insolvency of the supplier.

The MRPL right to cancel the contract under the terms, aforesaid shall be without prejudice to any of its other rights and remedies against the successful tenderer In the event of MRPL cancelling the contract, it shall not be liable to pay for any loss or compensation in respect of such cancellation.

15.3 TERMINATION :

The OWNER shall be entitled to terminate the Contract by written notice at any time during or after the occurrence of any one or more of the following events or contingencies, namely:

- i. Failure to start the work /provide services within 10 (ten) days of Placement of order to the CONSULTANT.
- ii. Failure to provide at each job site sufficient labour, material, equipment, machinery, temporary work and/or facilities required for the proper and/or due execution of the work or any part thereof;
- iii. Failure to execute the works or any of item in accordance with the Contract;
- iv. Disobedience of any order or instruction of the Engineer-in-Charge and/or Site Engineer;
- v. Negligence in carrying out the works or carrying out of work found to be unsatisfactory by the Engineer-in-Charge/OWNER;
- vi. Abandonment of the works or any part thereof;
- vii. Suspension of the entire works or any part thereof, for a period of 14 (fourteen) days or more without due authority from the OWNER or Engineer-in-Charge.
- viii. Commission, permission or sufferance of any other breach of any of the terms, conditions or provisions of the Contract on the part of the CONSULTANT to be paid, performed and/or observed;
- ix. Failure to deposit the Initial Security Deposit within 15 (Fifteen) days of receipt by the CONSULTANT of Acceptance of Tender;
- x. If the CONSULTANT is incapable of carrying out the work.
- xi. If the CONSULTANT misconducts himself in any manner.
- xii. Dissolution of the CONSULTANT (if a firm) or commencement of liquidation or winding up (whether voluntary or compulsory) of the CONSULTANT (if a company) or appointment of a receiver or manager of any of the CONSULTANT 's assets and/or insolvency of the CONSULTANT (if a sole proprietorship) or any Partner of the CONSULTANT (if a firm);
- xiii. Distress, execution, or other legal process being levied on or upon any of the CONSULTANT's goods and/or assets.
- xiv. Death of a CONSULTANT (if an individual).
- xv. If upon any change in the Partnership/constitution of a CONSULTANT's organization (if a Partnership), the OWNER shall refuse to continue the contract with the re-constituted firm.



ENGINEERING, PROCUREMENT AND CONSTRUCTION MANAGEMENT (EPCM) SERVICES FOR INSTALLATION OF LPG AMINE ABSORBER SYSTEM IN PFCC UNIT AT MRPL, MANGALURU

- xvi. If the CONSULTANT or any person employed by him shall make or offer for any purpose connected with the Contract any gift, gratuity, royalty, commission, gratification or other inducement (whether money or in any other form) to any employee or agent of the OWNER.
- xvii. MRPL on assessment of consultant's performance determines that the Consultant administration of the contract/scope would be determinable to the interest of MRPL and or may result in unwanted litigation/claim by the contractor.
- xviii. MRPL on assessment of consultant's performance determines that the Consultant administration of the contract/scope would result in unwarranted financial and or any other liability on MRPL present or future.
- xix. Failure to provide the required technical and or the recommendation within the period as provided under the Contract.
- xx. Failure to address and provide resolution/recommendation within the period as provided under the Contract for the issue raised by the Contractor.

15.4 TERMINATION FOR CONVENIENCE:

Notwithstanding anything contained in the Contract, the Employer may, by 30 (Thirty) days written notice, terminate the Contract in whole or in part. In addition to the payment mentioned at GCC clause 30.3, the Service Provider shall be compensated for de-mobilization and other costs incurred at mutually negotiated terms. In case of such termination, the obligation of the OWNER to pay, shall be limited to the extent of work/job completed by the Service Provider as per provision of the Contract upto the date of termination, subject to the Service Provider complying with other terms of the Contract. Notwithstanding the termination of the Contract, the parties shall continue to be bound by the provisions of this Contract that reasonably require some action or forbearance after such termination.

15.5 RISK PURCHASE CLAUSE

In the event of Consultant not accepting/not meeting the indent/order/contract placed by the Owner with in the stipulated time, then Owner would be free to use the services of any others without notice unconditionally and recover the difference in such services and additional expenses incurred by the Owner from the Consultant.

ARTICLE – 16

(PATENTS)

- 16.1 CONSULTANT shall, subject to the limitations contained in this Article, indemnify and hold MRPL harmless from all costs, damages and expenses arising out of any claim, action or suit brought against MRPL by third parties in respect of any infringement of any patent or registered design or process or design belonging to CONSULTANT and furnished to MRPL. MRPL shall promptly notify CONSULTANT in writing of any claim preferred or any such similar right. CONSULTANT shall at its own cost take such legal action as may be necessary for defending the same and MRPL shall render all such reasonable assistance in this behalf as may be required by CONSULTANT.



**ENGINEERING, PROCUREMENT AND CONSTRUCTION MANAGEMENT (EPCM) SERVICES FOR
INSTALLATION OF LPG AMINE ABSORBER SYSTEM IN PFCC UNIT AT MRPL, MANGALURU**

- 16.2 Similarly MRPL shall indemnify and hold CONSULTANT harmless from all costs, damages and expenses arising out of any claim, action or suit brought against CONSULTANT by third parties in respect of any infringement of any patent or registered design or any similar rights resulting from the use of any information furnished to CONSULTANT by MRPL or by others on behalf of MRPL.

ARTICLE – 17

(ASSIGNABILITY)

- 17.1 The contract and benefits and obligations thereof shall be strictly personal to the PARTIES and shall not on any account be assignable or transferable by the PARTIES except with the prior agreement in writing.

ARTICLE – 18

(CESSATION OF CONSULTANT'S SERVICES)

- 18.1 Upon CONSULTANT's Warranties and Guarantees referred to in this contract as Exhibit-7 having been or being deemed to have been satisfied or twelve months from the date of commissioning or Eighteen months from the date of Mechanical Completion whichever occurs first, (Defect Liability period) all responsibilities of CONSULTANT under this contract shall be deemed to have been discharged.
- 18.2 Date of acceptance as referred above shall mean the date on which MRPL confirms written acceptance of CONSULTANT SERVICES. The SERVICES shall be deemed to have been accepted unless Consultant is notified by MRPL to the contrary within 90 days of completion of said SERVICES.

ARTICLE – 19

(MECHANICAL COMPLETION)

- 19.1 Mechanical completion is condition achieved when,
- The Plant or facility has been erected in accordance with relevant drawings, documents, specifications, instructions and applicable codes and regulations, safety standards.
 - The work detailed as per scope of services has been completed. Consultant shall prepare a detailed list of services to be completed before MC and after MC for each discipline (Mechanical/ Electrical/ Process/ Instrumentation/ Critical Rotary/ Piping/ Inspection etc) Minor remaining works, removal of scaffolding, temporary piping and minor left out housekeeping can be done after mechanical completion but shall be completed before start up
 - All the deficiencies that could prevent safer and orderly commissioning activities have been rectified.
 - Defined Tie-in work to the operating plant will be carried out during the opportune moments prior to Mechanical Completion.
 - Ensuring a phased Mechanical completion programme to facilitate sequential pre-commissioning activities culminating in a logical commissioning programme of various facilities of the Revamp.
 - Review formats of handing over including required documentation, construction completion certificates and mechanical completion certificate.



**ENGINEERING, PROCUREMENT AND CONSTRUCTION MANAGEMENT (EPCM) SERVICES FOR
INSTALLATION OF LPG AMINE ABSORBER SYSTEM IN PFCC UNIT AT MRPL, MANGALURU**

- g. When the revamp has been completed, other than in minor respects (as per discretion of MRPL) which do not prevent commissioning, all major MRPL's checklist points liquidated (FORMAT-3), consultant shall notify MRPL in writing that the revamp is Mechanically completed and ready for pre-commissioning activities and trial runs. The date of readiness for pre-commissioning as aforesaid shall be deemed to be the date of MECHANICAL COMPLETION for the purpose of this contract.

ARTICLE – 20

(CHANGES AND ADDITIONS IN CONSULTANT 'S SCOPE OF SERVICES)

- 20.1 MRPL shall have the right to request CONSULTANT in writing to make any changes, modifications, deletions and/or additions to CONSULTANT's scope of SERVICES without altering the ingredients of the material services/scope. In cases the changes suggested by MRPL would amount to addition to consultant scope, CONSULTANT will work out and submit without undue delay, the estimate of price and time adjustment on account of such changes, modifications, deletion and/or additions sought by MRPL. If the MRPL does not agree to CONSULTANT's reply to a fore stated request or any part thereof, MRPL shall promptly notify CONSULTANT in writing. PARTIES shall then meet and discuss the same for mutual agreement at the earliest without jeopardizing the PROJECT activities. If no such agreement is reached between PARTIES within 30 days from the date of such meeting / discussion, MRPL decision as to changes amounting to addition and to what extent would be final and binding on the Consultant
- 20.2 CONSULTANT shall not be entitled to price and/or schedule adjustment to reflect the impact of any event not attributable to OWNER unless approved by owner in writing.

ARTICLE – 21

CONTRACT PERFORMANCE BANK GUARANTEE / SECURITY DEPOSIT (SD)

- 21.1 Within 15 days of award of work order, CONSULTANT shall deposit with MRPL , an amount equivalent to 10 % of Order value as interest free security deposit towards due & satisfactory performance of contract.
- 21.2 SD shall be submitted In the form of Pay order or Demand Draft in favour of MRPL drawn on a Nationalised / scheduled bank payable at Mangalore on which no interest will be payable.

OR

In the form of Bank Guarantee from Nationalised / scheduled bank acceptable to MRPL (Format as per Exhibit 10). as per company standard Performa which is enclosed. The Bank Guarantee shall cover the defect liability period.

The irrevocable Bank Guarantee (BG) in the prescribed format if submitted against PBG/SD. shall be subject to verification from the issuing Bank, the email ID of bank for the same must be incorporated in the BG.

The BG issued by the issuing Bank on behalf of Bidder/Contractor/Supplier in favour of "Mangalore Refinery and Petrochemicals Limited" shall be in paper form and also be made available under the "Structured Financial Messaging System" (SFMS).



**ENGINEERING, PROCUREMENT AND CONSTRUCTION MANAGEMENT (EPCM) SERVICES FOR
INSTALLATION OF LPG AMINE ABSORBER SYSTEM IN PFCC UNIT AT MRPL, MANGALURU**

A separate advice of the BG will invariably be sent by the issuing bank to the beneficiary's Bank through SFMS and SFMS transmission message reference number (currently 32 digits code) is to be sent along with BG directly to MRPL through speed post/regd. Post.

The details of beneficiary for issue of BG under SFMS platform is furnished below:

Name of Beneficiary: Mangalore Refinery and Petrochemicals Limited

Beneficiary Bank, Branch and address: Union Bank of India (Erstwhile Corporation Bank), MRPL Project Site, Kuthethoor Post Mangalore 575030, Karnataka

IFSC code: CORP0000592

SWIFT Code: CORPINBB

MICR Code: 575017015

Any bank guarantee submitted in physical mode which cannot be verifiable through SFMS will not be accepted under any circumstances.

- 21.3 MRPL is entitled without being bound to do so, to adjust the whole or any portion of the security deposit towards the recovery of any amount due to MRPL from the successful tenderer. The Security Deposit or such portion thereof that has not been adjusted towards recovery of amount due from the successful tenderer will be refunded within 15 days of on satisfactory completion of the contract or after the expiry of DEFECT LIABILITY PERIOD wherever applicable. No interest is payable by MRPL to the successful tenderer on the security deposit and or towards bank charges/commission paid by the Consultant on the same.
- 21.4 Security deposit shall be forfeited in case the vendor fails to execute the order

**ARTICLE – 22
(AMENDMENT)**

- 22.1 Any amendment to the terms and conditions of this CONTRACT, including the Exhibit and the amendments, if any, shall be made in writing by PARTIES hereto and shall specifically state that it is an amendment to this CONTRACT.

**ARTICLE 23
(LIMITATION OF LIABILITY & EXCLUSION OF GOVT OF INDIA'S LIABILITY)**

23.1 LIMITATION OF LIABILITY :

- 23.1.1 The aggregate total liability of the Consultant to Owner under the Contract shall not exceed 20 % of the total Contract Price, except that this Clause shall not limit the liability of the Consultant for following:
- In the event of breach of any Applicable Law;
 - In the event of fraud, willful misconduct or illegal or unlawful acts, or gross negligence of the Consultant or any person acting on behalf of the Consultant ; or
 - In the event of acts or omissions of the Consultant which are contrary to the most elementary rules of diligence which a conscientious Consultant would have followed in similar circumstances; or
 - In the event of any claim or loss or damage arising out of infringement of Intellectual Property; or



ENGINEERING, PROCUREMENT AND CONSTRUCTION MANAGEMENT (EPCM) SERVICES FOR INSTALLATION OF LPG AMINE ABSORBER SYSTEM IN PFCC UNIT AT MRPL, MANGALURU

e) For any damage to any third party, including death or injury of any third party caused by the Consultant or any person or firm acting on behalf of the Consultant in executing the Works.

23.1.2 Neither Party shall be liable to the other Party for any kind of indirect nor consequential loss or damage like, loss of use, loss of profit, loss of production or business interruption which is connected with any claim arising under the Contract.

23.2 EXCLUSION OF GOVT OF INDIA'S LIABILITY

It is expressly understood and agreed that the MRPL will enter into this Contract solely on its own behalf and not on behalf of any other person or entity. In particular it is expressly understood and agreed that the Government of India are not party to any such Agreement and will have no liabilities, obligation or right whatsoever hereunder. It is expressly understood and agreed that the MRPL is an independent legal entity with power and authority to enter into Contracts solely on its own behalf under the applicable laws of India. CONSULTANT expressly agrees, acknowledges and undertakes that the MRPL is not an agent, representative or delegate of the Government of India and that of the Government of India are not and shall not be liable for any act, omission, commission breach or other wrong arising out of this Contract. CONSULTANT hereby expressly waives, releases and forgoes any and all actions or claims, including cross claims, impleader claims or counter claims, against the Government of India arising out of any resultant agreement and covenants not to sue the Government of India for any manner of claim, cause of action or thing whatsoever arising out of or under any such Contract.

**ARTICLE – 24
(MISCELLANEOUS)**

24.1 MRPL shall perform any and all activities, make available information and provide all approvals within a period of 14 days of receipt of documents or at such time as may be necessary to enable CONSULTANT to execute its services efficiently and without disruption or delay.

24.2 MRPL shall provide free and unrestricted access to the site in time as mutually agreed by the PARTIES.

IN WITNESS WHEREOF the PARTIES hereto have duly executed this CONTRACT in two originals at the place and date as follows:

For and on behalf of MRPL
Signature _____
Name
Designation
Place
Date

For and on behalf of Consultant
Signature _____
Name
Designation
Place
Date

Witness
1
2.

Witness
1.
2.



**ENGINEERING, PROCUREMENT AND CONSTRUCTION MANAGEMENT (EPCM) SERVICES FOR
INSTALLATION OF LPG AMINE ABSORBER SYSTEM IN PFCC UNIT AT MRPL, MANGALURU**

EXHIBITS

For

**ENGINEERING, PROCUREMENT AND CONSTRUCTION
MANAGEMENT (EPCM) SERVICES FOR INSTALLATION OF LPG
AMINE ABSORBER SYSTEM IN PFCC UNIT AT MRPL,
MANGALURU.**

Tender No.: 3200000464



EXHIBIT-1 PROJECT DESCRIPTION

1.0 INTRODUCTION

Mangalore Refinery and Petrochemicals Limited (MRPL) a government of India schedule A, CPSE and a subsidiary of Oil and Natural Gas Corporation Limited (ONGC) is a State of Art Grass root Petroleum Refinery located in a beautiful hilly terrain, north of Mangalore city, in Dakshina Kannada region, Karnataka State. The Refinery has got a versatile design with high flexibility to process Crudes of various API and with high degree of Automation. MRPL has high standards in refining and environment protection matched by its commitments to society. MRPL has also developed a Green Belt around the entire Refinery with plant species specially selected to blend with the local flora.

Mangalore Refinery and Petrochemicals Limited (MRPL), is operating a 15.25 MMTPA fuels refinery at Mangalore. The Refinery complex is integrated to Aromatic Complex and designed to produce 900,000 TPA of Paraxylene.

2.0 LPG AMINE ABSORBER SYSTEM

MRPL has installed Petrochemical Fluidized Catalytic Cracking (PFCC) unit with capacity of 2.2 MMTPA and unit was commissioned in 2014. The process technology licensed by M/s. Technip Stone and Webster. Processing feed with higher Sulphur content in PFCCU, higher H₂S is expected in LPG stream. A New LPG Amine Treatment unit shall be installed to remove the hydrogen sulfide present in the LPG and to minimize the spent caustic generation in existing caustic treatment system.

Proposed LPG Treatment Facility:

The primary objective of New LPG Amine Treatment Unit is to treat H₂S and minimize spent caustic generation. LPG from debutanizer overhead will be routed to new LPG Amine absorber where H₂S is absorbed using lean amine. The bottoms containing rich amine will be sent to Amine Regeneration Unit (ARU). The regenerated Lean amine from ARU is circulated to the absorber.

A typical block flow diagram of the proposed facility is given below.

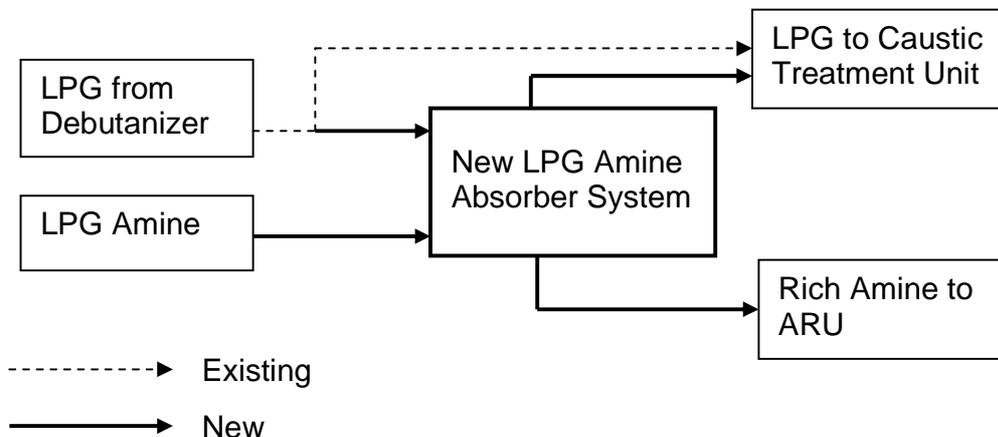



**ENGINEERING, PROCUREMENT AND CONSTRUCTION MANAGEMENT (EPCM) SERVICES FOR
INSTALLATION OF LPG AMINE ABSORBER SYSTEM IN PFCC UNIT AT MRPL, MANGALURU**

Brief Scope of Work

- 1.1) LPG Amine Absorber System shall be designed for the following design cases:
- A) Design Case I:** Sour LPG Streams (C3 and C4 stream) with a flow Rate: 170.520 TPH with Feed Sulphur (H₂S): 100 ppmw
 - B) Design Case II:** Sour LPG Streams (C3 and C4 stream) with a flow Rate: 170.520 TPH with Feed Sulphur (H₂S): 200 ppmw
- Product quality: Guaranteed treated LPG shall have H₂S of 15 ppmw.
- 1.2) LPG Amine Absorber System shall consist of following sections:
- LPG Amine Contactor
 - LPG Water Wash Coalescer
 - Lean Amine Surge Drum and Pump
 - Rich Amine Break Vessel and Pump
- 1.3) LPG Product Specification for the New LPG Amine Treatment Unit shall be designed for following specifications:
- H₂S in LPG ex new LPG amine contactor is 15 ppmw.
 - Amine carryover to LPG is 100 ppmw.
 - Hydrocarbon carryover to amine is 0.2 wt%
- 1.4) Process Package received from Licensor M/s. Technip Stone and Webster will be issued to the successful bidder. All residual and detailed engineering to be carried out thereon by the Consultant. Any inconsistency, incompleteness or any clarifications in the process package the Consultant shall contact the Licensor and obtain the resolution accordingly.



EXHIBIT-2

Scope of services

1.0 Brief Scope of Work:

The scope of work broadly includes detailed Engineering, Procurement, Construction management, Mechanical Completion and Commissioning of the unit. This shall include but not limited to Project Management, Detailed Engineering, Procurement Services, Inspection and Expediting, Construction Management, safety Supervision of required facilities. The scope includes but not limited to Civil, Structural, Architectural, UG piping, Mechanical, Piping, Electrical, Instrumentation, Insulation, Painting, Assistance in obtaining statutory clearance, Assistance during Pre-commissioning, Start-up, Commissioning and performance test for the unit.

The details of the facilities envisaged are mentioned in this document. It is not the intention of this document to completely specify all the services required during engineering, manufacture and construction. Nevertheless, the services provided shall conform to the highest standards in a manner acceptable to MRPL. Any additional facility and service which are not specifically mentioned here, but are required to make the unit complete in every respect in accordance with the intent and technical specification and for safe operation and guaranteed performance shall be covered under the scope of work. Bidder shall provide the hydraulic guarantee of the complete unit / system.

M/s. TECHNIP STONE AND WEBSTER is the licensor for PFCC Unit and for the LPG amine absorber system. Consultant shall coordinate with M/s. TECHNIP STONE AND WEBSTER for obtaining clarification and technical inputs with respect to the BEDP carried out by them, interface issues etc. and for all services as required in this tender for LPG Amine Treatment Unit. The Consultant shall review all documents as required for LPG Amine Treatment Unit which will be furnished by Licensor/ MRPL. The Consultant shall visit the project site during Kick Off meeting and collect all the existing unit documents as required in as available format from the EDC of MRPL.

The Consultant will report directly to MRPL with respect to the project management, control and execution of the project. The successful bidder may have to enter into a secrecy agreement with M/s. TECHNIP STONE AND WEBSTER.

Process Package received from Licensor M/s TECHNIP STONE AND WEBSTER will be issued to the successful bidder and as built P&ID of existing unit also will be issued to the successful bidder. Consultant to carry out the detail engineering considering as-built P&ID and Process Package. Consultant scope includes adequacy check of all the existing equipment, piping and instruments associated in the loop from LPG pumps up to Depropoanizer inlet. Consultant to take up cost estimate and procurement action for any equipment, instruments and safety valves as replacement for existing equipment, instruments and safety valves for the project and also for any new equipment envisaged as per BEDP. Further scope of work of EPCM Consultant envisaged is listed below:

- i. Carry out residual, basic engineering and detailed engineering based on basic engineering package of M/s. TECHNIP STONE AND WEBSTER.



ENGINEERING, PROCUREMENT AND CONSTRUCTION MANAGEMENT (EPCM) SERVICES FOR INSTALLATION OF LPG AMINE ABSORBER SYSTEM IN PFCC UNIT AT MRPL, MANGALURU

- ii. Carry out detailed engineering towards modifications as required in DCS, Satellite rack room (SRR) and electrical substation.
- iii. Carry out detailed engineering of streams coming from other units / OSBL facilities based on detailed engineering / input from MRPL required for the LPG Amine Treatment Unit.
- iv. Basic and Detailed engineering for hook-ups at ISBL and OSBL.
- v. To carry out detailed engineering of utilities such as Cooling water, Instrument air, steam, nitrogen, chemical injection pumps and piping, Fire Water, Utility Water, Plant Air etc. required for the LPG Amine Treatment Unit.
- vi. Updation of revised unit plot plan and all other drawings incorporating the required details of the LPG Amine Treatment Unit.
- vii. Prepare and submit the complete unit P&ID, based on existing as-built P&ID, Licensor Process Package, detailed engineering carried out by the Consultant, comments of MRPL and any other details required for completing the work.
- viii. Submission of drawings based on detailed engineering.
- ix. Submission of drawing / documents required for statutory approvals such as PESO, IBR factories, CEA etc. and obtaining / assisting for statutory approvals where ever possible.
- x. To undertake and submit detailed cost estimate of with accuracy up to + / - 10%.
- xi. Procurement services based on the detailed engineering, inspection, expediting and Ware house management including Material receipt, IMRV, SAT and Material issue to site contractor
- xii. Construction and Erection Management of Procured equipment / piping / electrical / instrumentation / civil and testing
- xiii. Procurement services based on HAZOP for the proposed LPG Amine Treatment Unit. HAZOP shall be performed after completion of all necessary adequacy check.
- xiv. Submission of Final HAZOP and Implementation of HAZOP recommendation before completion of Project.
- xv. Any residual engineering, procurement, and erection required for completion of the job in all respect.
- xvi. Safety management and supervision.
- xvii. Quality during construction and at vendor shop and during execution of work at site.
- xviii. Vendor and Contractor bill certification.
- xix. Material reconciliation and handing over of excess material to MRPL stores and assisting in codification in SAP of returned excess materials to stores
- xx. Assistance during pre-commissioning and commissioning and PGTR.
- xxi. Contract closure of all works / purchase contracts / orders within 09 months from Mechanical Completion
- xxii. Assistance to MRPL for a period of 24 Months from Mechanical Completion, for contractor litigation / vigilance, audit, Govt Authorities queries. If the Consultant has demobilised from site during this period, then the assistance shall be provided from Consultant Engineering / Main Office as required.
- xxiii. Final documentation as per procedure.
- xxiv. Obtaining / Assisting MRPL, for all statutory approvals required for the project (PESO, Factories, IBR, CEA, TAC etc)



ENGINEERING, PROCUREMENT AND CONSTRUCTION MANAGEMENT (EPCM) SERVICES FOR INSTALLATION OF LPG AMINE ABSORBER SYSTEM IN PFCC UNIT AT MRPL, MANGALURU

- xxv. Conducting PGTR of the LPG Amine Treatment Unit and hydraulic guarantee of the unit. Any failure in hydraulic performance, Consultant to carryout re-engineering and execution without time and cost implication.
- xxvi. Re-drawing of complete (existing and new) P&ID including utilities based on the P&ID received from Licensor in native form, P&ID of existing unit submitted by MRPL in native form and detailed engineering carried out by Consultant for the unit.
- xxvii. Carryout evaluation of structural soundness of existing RCC and Steel structure which shall be used (if any) for installation of the LPG Amine Treatment Unit and to carry out modification / rectification work as required for the project.
- xxviii. Carryout underground scanning works wherever required
- xxix. Carry out 3D modelling of the proposed unit (30%, 60% & 90% completion of engineering)
- xxx. Carryout 3D Laser scanning and mapping works wherever required
- xxxi. Utility summary including flare.

The below equipment may get tentatively added / modified as a part of project. The list is not exhaustive and there may be addition or deletion of equipment and addition / deletion of modification of equipment as decided by EPCM Consultant.

Sl. No.	Description	Equipment Tag No.	New / Replaced / Modified
1	LPG ATU Amine Coalescer	FA-33251	New
2	LPG ATU Lean Amine Surge Drum	FA-33252	New
3	LPG ATU Rich Amine Break Vessel	FA-33253	New
4	LPG ATU LPG Wash Water Circulation Pumps	GA-33258 A/B	New
5	LPG ATU Lean Amine Pumps	GA-33259 A/B	New
6	LPG ATU Rich Amine Pumps	GA-33260 A/B	New
7	LPG ATU Wash Water Injection Pumps (Positive Displacement)	GA-33261 A/B	New
8	LPG ATU Coalescer Mixer	GD-33203	New
9	LPG Pumps	GA-33222A/B	Replaced / Modified
10	LPG Amine Contactor	DA-33211	New

Others jobs

1. PLC / DCS upgradation as per changes and requirement
2. HAZOP / SIL study of process changes
3. Flare / CBD / utility connection and adequacy check
4. E&I work / ISBL piping
5. Process piping, Instruments and utility piping connection leak testing for new and associated existing piping during commissioning phase.
6. Existing SRR is adequate however if during detailed engineering if space is found inadequate additional SRR have to be built.



ENGINEERING, PROCUREMENT AND CONSTRUCTION MANAGEMENT (EPCM) SERVICES FOR INSTALLATION OF LPG AMINE ABSORBER SYSTEM IN PFCC UNIT AT MRPL, MANGALURU

7. Existing Sub stations is adequate however if during detailed Engineering if space is found inadequate additional substation have to be built
8. Fire Water Network extension if existing one not adequate as per OISD and TAC guidelines

Consultant's scope of services is covered under the following broad areas:

- A. Project Management and Control
- B. Engineering
- C. Procurement Management- including Tendering, Inspection, Expediting and Warehouse Management
- D. Construction Management and Supervision
- E. Pre-commissioning and Commissioning, start up and PGTR assistance
- F. Cooperation and Coordination with Process Licensors, Other Consultants, Contractors and Suppliers

A. Project Management and Control

A1. Overall Project Coordination and Management

1. Responsible for integrated proper management, support, contracting, monitoring, control, measurement, coordination and reporting for the total project with due focus on project cost, contractual schedule and quality control.
2. Responsible for design integrity and detailed engineering complete in all respects.
3. Co-ordination with TECHNIP STONE AND WEBSTER and other suppliers / contractors / vendors.
4. Assistance to MRPL for the resolution of technical and commercial disputes with suppliers / contractors / vendors.
5. Consultant to provide detailed Work Breakdown Structure (WBS) on monthly basis clearly identifying the components of the assets created (including appropriate allocation of common orders) under this contract reconciling to project cost.
6. Immediately after completion of individual orders placed, the Consultant to issue certified order close-out report.
7. Consultant shall provide overall project management services covering the following areas:
 - a. Establish Project Management System and Procedures
 - b. Project Execution philosophy
 - c. Planning and Scheduling, Control and Monitoring
 - d. Cost Control and Estimation
 - e. Change Order Control Management.
 - f. Project Documentation Control & approval philosophy
 - g. Recommendation on PRS applicability and Extension of completion schedules
8. Consultant shall prepare the following documents for Project implementation as per the requirements of the Project:
 - a. Coordination Procedure between MRPL, Consultant, Licensors etc. including but not limited to communication procedure, addresses and contact persons and correspondence numbering system
 - b. Project Organization and Project Schedules
 - c. Project Execution philosophy
 - d. List of reports and sample formats.



**ENGINEERING, PROCUREMENT AND CONSTRUCTION MANAGEMENT (EPCM) SERVICES FOR
INSTALLATION OF LPG AMINE ABSORBER SYSTEM IN PFCC UNIT AT MRPL, MANGALURU**

- e. Project Document Control procedures to ensure timely receipt and distribution of drawings and documents and shall cover document numbering system, time for review / submission, document distribution quantities, transmittal formats etc.
- f. Procedures for Quality Assurance, Inspection, Construction Management, Safety, Cost Control, Progress Reporting, Change Orders, System handing over etc.
- g. Prepare a comprehensive QAP for the Project so as to ensure quality standards with various vendors.

A2. Establish Project Management Systems and Procedures

1. Develop project strategy and schedules, scope and procedure including those for procurement and construction, contracts and establish formal lines of communication with MRPL, vendors and site contractors.
2. Review of BEDP packages and coordinate with TECHNIP STONE AND WEBSTER for clarifications. Co-ordinate with TECHNIP STONE AND WEBSTER on adequacy checks / outcome.
3. Ensure completeness and consistency of the process package with respect to data sheets, drawings, specifications and other data received from or developed by the Licensor during the preparation of the process package.
4. Review of PID, co-ordinate with TECHNIP STONE AND WEBSTER on HAZOP recommendations on final P&ID.

A3. Planning and Scheduling, Control and Monitoring

1. Establish monitoring, reporting and project information systems for management action and control.
2. Preparation and finalization of schedules in discussion with MRPL.
3. Preparation of an overall project schedule / network, identifying critical path, WBS, priority activities and target dates for completion.
4. Review and updating project schedule / network regularly.
5. Preparation of detailed discipline-wise schedules for setting out targets.
6. Monitoring purchasing, expediting and inspection activities and initiate such actions as may be required for timely delivery of purchased items to the project site. Joint visits with MRPL shall be organized for expediting to vendor's shop for critical orders in India or abroad as mutually agreed between Consultant and MRPL.
7. Monitoring project progress and identifying bottlenecks.
8. Monthly submission of progress reports to MRPL in formats as required by MRPL for review by MRPL / Government authorities.
9. Consultant shall organize and conduct Monthly / Weekly / Daily progress reviews. Monthly progress review meeting locations shall be mutually decided. Weekly / Daily progress review meetings shall be at site.
10. Consultant shall identify all items for this project and take action for procurement of the same.

A4. Cost Control and Estimating

1. Consultant services shall include cost estimation (+/- 10% accuracy) for each tendered purchase / service order in a format as required by MRPL with detailed backup, basis and justification. This shall be the basis for cost control and monitoring for the entire project.



ENGINEERING, PROCUREMENT AND CONSTRUCTION MANAGEMENT (EPCM) SERVICES FOR INSTALLATION OF LPG AMINE ABSORBER SYSTEM IN PFCC UNIT AT MRPL, MANGALURU

2. Prior to ordering of any item, availability / physical verification of the item (along with the required test certificates) in MRPL is to be checked by the Consultant.
3. Bulk materials means items like pipes, pipe fittings, valves, flanges, steam traps, steel plates, structural steel, HT and LT cables, control cables, light fitting junction boxes and fittings, signal, power, OFC and thermocouple cables, instrument tubing, valves and manifolds etc., If the total value of surplus bulk materials on completion of work exceed 5% of the total value of the bulk materials procured for the work, it will attract a penalty at the rate 1% of lump sum contract price for every 1% over and above 5% of the surplus bulk material cost subject to maximum of 5% of the lump sum contract price or 10% of the value of surplus bulk material beyond allowable limit of 5%, whichever is lower.
4. If the value of the items procured / contracts awarded for the project exceeds 10% of the total value of the cost estimate submitted by the Consultant for the items procured / contracts awarded, a penalty of 10% value of the items procured / contracts awarded beyond allowable limit of 10% is applicable to the maximum of 5% of the total EPCM contract value. This penalty is over and above the penalty mentioned for surplus bulk material.
5. Consultant shall furnish expenditure forecast (monthly, quarterly and annually) for submission by MRPL for financial planning and to government authorities for costs related to entire project.
6. Consultant shall regularly monitor the project cost during entire project duration and shall be submit monthly reports to MRPL
7. Project cost estimation shall be updated on regular basis based on the forecast. Consultant shall prepare detailed WBS indicating the cost to each item.
8. Consultant shall submit as-built cost after the completion of the project.
9. Consultant shall provide details of capitalisation of assets as when required.

A5. Change Order Control Management

Any project scope changes will also be scrutinized by Consultant and supplier / contractor proposal in this regard will be vetted by Consultant.

A6. Project Documentation Control

1. Consultant shall formulate and adopt a suitable document control and transmittal system (which are also to be followed by vendors / contractors / suppliers) to ensure timely receipt and distribution of documents and shall follow the project document procedure furnished by MRPL.

B. Engineering

B1. Engineering Management

1. Consultant shall be the nodal point for coordination between Technology Suppliers, Licensors, Vendors, Contractors and MRPL.
2. Consultant shall ensure that design drawings / documents meet all statutory requirements.
3. Consultant shall incorporate all features necessary to ensure safety of plant personnel.
4. Consultant shall ensure timely submission of drawings / documents in order to meet project schedule requirements.



ENGINEERING, PROCUREMENT AND CONSTRUCTION MANAGEMENT (EPCM) SERVICES FOR INSTALLATION OF LPG AMINE ABSORBER SYSTEM IN PFCC UNIT AT MRPL, MANGALURU

5. Consultant shall prepare detailed operating manual based on operating instructions and guidelines from Technology Suppliers / Licensors.

B2. Process Design – BEDP

1. Process design is prepared by M/s TECHNIP STONE AND WEBSTER. Typical Content of Process Package is as follows:
 - a. Process Design Basis
 - b. Process Flow Diagram (PFD) with Stream Data Summary
 - c. Process Description
 - d. P&IDs
 - e. Metallurgical Flow diagrams.
 - f. Instrumentation Cause and Effect diagrams.
 - g. Equipment List
 - h. Process Data Sheets for equipment
 - i. Process Data sheets for instruments
 - j. Line Schedule
 - k. Utility Summary (Equipment wise)
 - l. Catalyst / Chemical Requirement
 - m. Effluent Summary and Flare Load Summary
 - n. Piping Material Specification
 - o. Supervisory Operating Instructions
 - p. Indicative Unit Plot Plan / Equipment Layout.
 - q. Hydraulic Summary
2. Consultant shall review documents submitted by TECHNIP STONE AND WEBSTER which shall be basis of further work of the Consultant.
3. Consultant shall coordinate with TECHNIP STONE AND WEBSTER for clarifications and resolutions of all the issues, which are required for completing the work and performance of Consultant's services. Consultant may use these documents for the purpose of detailed engineering. These documents will be furnished to the successful bidder. Bidder will be required to enter into a secrecy / NDA agreement with TECHNIP STONE AND WEBSTER.

B3. Detailed Engineering

B3.1. General

1. Review existing Engineering Design Basis (EDB) in various disciplines and adopt the same with suitable modifications if required after approval from MRPL. EDB shall be issued to the successful bidder.
2. Consultant shall provide necessary assistance, wherever required for providing technical inputs for all statutory clearances to be obtained by MRPL.
3. HAZOP shall be carried out by Consultant in participation with Licensor, Technology Supplier, MRPL as the case may be and all the recommendations shall be incorporated during detailed engineering and furnished to MRPL and TECHNIP STONE AND WEBSTER.
4. Issue of as-built P&IDs including incorporating of P&IDs of sub-units which are interconnected to the LPG Amine Treatment Unit where-ever required.



ENGINEERING, PROCUREMENT AND CONSTRUCTION MANAGEMENT (EPCM) SERVICES FOR INSTALLATION OF LPG AMINE ABSORBER SYSTEM IN PFCC UNIT AT MRPL, MANGALURU

5. Engineering for hook-ups at Battery Limit (B/L) or other locations inside the B/L as required.
6. Review of as-built drawings (if any) prepared by contractors and submission of all as-built drawings prepared by Consultant and contractors to MRPL
7. Consultant shall participate in meetings with any authority as required by MRPL and provide technical inputs for all statutory clearances as required.
8. Consultant shall note that drawings as required by the Licensor will be reviewed by the Licensor and any changes as required by the Licensor shall be incorporated in the drawings and suitably implemented at site.
9. If during detailed design, Consultant is required to change any Licensor provided data, the same will be referred to Licensor for their concurrence. Consultant shall ensure that due to detailed engineering of the Consultant the Guarantees provided by the licensor suppliers are not diluted.
10. All requirements as stipulated in the Central and State Consent-For-Establishment (CFE) / Environmental clearance shall be suitably incorporated in the detailed design developed by the Consultant.
11. Hazardous area classification drawing to be prepared and submitted.
12. Preparation, review and approval of tender specifications with schedule of quantities for all equipment and works of civil, mechanical, electrical, instrumentation, structural, piping, painting, insulation and any other discipline as required, technical drawings and technical evaluation of bids.
13. Review and approval of all drawings submitted by contractors.
14. Preparation of drawings as required by Chief Inspector of Factories, PESO, CEA, CEIG and any other statutory authority as required.
15. Preparation of Material Requisition (MR) and Purchase Requisition (PR) for all equipment, items and materials, piping, bulk items, E&I items etc. as required.
16. Preparation of Job/Work Requisition for soil investigation, Civil & Structural, Piping & Mechanical, E&I contract for site related works
17. Equipment layout shall be prepared based on area allocated and requirement of Technology Suppliers and Licensor meeting all statutory, maintenance and operation requirements.
18. Drawing-up list of equipment for fire proofing and preparation of specification for fire proofing.

B3.2. Civil Design and Engineering

1. Soil investigation.
2. Site grading work if required.
3. Under-ground piping within ISBL and hook up with the nearest OSBL facility.
4. Internal road, approaches and drainage and interconnection to existing roads, approaches and drainages as the case may be.
5. Adequacy check of fire-fighting system, augmentation of the system if required and hooking up to the existing system as required shall be taken up by the Consultant. The fire-fighting system shall be designed with all required components like risers, monitors, sprinkler system, fin-fan coolers, booster pumps etc. as required to meet the requirement of the project and shall meet OISD and all statutory criteria.
6. Pavement for operating areas wherever required.



7. Service Water System, Condensate Recovery System, Contaminated Rain Water System, CBD System and Chemical Sewer System for the LPG Amine Treatment Unit and interconnection to the existing system as required.
8. Road crossing, sleepers, culverts etc.

B3.3. Structural Design and Engineering

1. Piling, piling layout drawings, soil improvement as required.
2. Preparation of foundations and foundation load data for various equipment, columns, structures, platforms, pump house, compressor house, substation, pipe rack, cable trenches, vessels etc.

B3.4. Pressure Vessels Design and Engineering

1. Preparation of mechanical design in accordance with specified codes

B.3.5. Heat and Mass Transfer Equipment

1. Review and validate the thermal design wherever carried out. If thermal design is not carried out by the Licensor / Technology Supplier, then Consultant shall carry out the same.
2. Mechanical design in accordance with specified codes to suit the process operating system.

B.3.6. Rotating Equipment Design and Engineering

1. Preparation of design and Specifications for all rotating equipment.

B.3.7. Piping

1. Finalization of piping material specification, classification and preparation of valve material specification according to process requirement and standard for process and utility lines based on the common PMS / VMS of the complex.
2. Preparation of GADs, Isometrics, Material take off etc. as required.
3. Review piping layout for package units for compliance.
4. Prepare IBR drawings / package for IBR approval.
5. Engineering and design of piping auxiliary support and isolation on piping layout.
6. Carrying out stress analysis using approved package.
7. Prepare list of piping and equipment for insulation, detailed specification of insulation material to be used, insulation thickness and application procedure etc.
8. Preparation of painting specifications and application procedure in accordance with existing MRPL specifications.
9. Determine battery limit connection points.

B.3.8. Instrumentation

1. Review of Engineering Design Basis for instrumentation and adopt the same with suitable modifications if required.
2. Sizing calculation for orifice plates and control valves / pressure relief valves.
3. Preparation of logic diagrams with write-up, functional schematics, field engineering inputs for DCS such as point database, graphics, auxiliary console layouts etc.
4. Preparation of all drawings related to field instruments including but not limited to
 - a. Cable duct / main trench, IRC layout drawing
 - b. Junction box and instrument location layout



ENGINEERING, PROCUREMENT AND CONSTRUCTION MANAGEMENT (EPCM) SERVICES FOR INSTALLATION OF LPG AMINE ABSORBER SYSTEM IN PFCC UNIT AT MRPL, MANGALURU

- c. Air supply distribution drawing
- d. Instrument installation standards
- e. Instrument hook up drawings (Prefabricated as well as fabricated type)
5. Preparation of field cable schedule
6. Participation in DCS / PLC Factory Acceptance Test / Site acceptance test, conducting FAT / SAT for any other systems to be supplied by contractor etc.
7. Coordinate the following with vendors / suppliers / site contractors
 - a. Calibration of instruments, hydro testing of impulse lines.
 - b. Installation and commissioning supervision of instruments / DCS
 - c. Loop checking of field instruments from field to control room in coordination with DCS vendor.
 - d. Cable laying up to rack room
 - e. Testing and simulation shutdown and process interlocks
 - f. Consultant shall carry out system study and adequacy check of the existing DCS and PLC system and suitable engineering solution with inputs as required shall be recommended to cater to the requirements of the project. The Consultant shall coordinate and witness simulation of process / equipment interlocks from field to control room PLC and also interface between DCS and third-party system as required.
8. Instrumentation engineering including as-built drawings / documents of cable schedules, loop diagrams, segment diagrams, termination drawings, and specifications of all field instruments like transmitters, orifices, control valves, temperature elements, thermowells, field switches, analysers etc. shall be prepared using engineering software tools.
9. Adequacy study of existing DCS of PFCC for catering to additional load of the LPG Amine Treatment Unit.

B.3.9. Electrical

1. Preparation of the following:
 - a. SLDs for all electrical circuits.
 - b. Specification and sizing of electrical equipment.
 - c. Area classification drawings
 - d. Equipment layout in sub-station
 - e. Lighting, lightning, earthing and cable layout drawings
 - f. Earthing calculations
 - g. Fire alarm, telephone and plant communication system layouts
 - h. Relay Coordination and setting
 - i. Adequacy study for existing PFCC substation transformers, switchboards, Cables, incoming feeders, UPS, DC system, etc for catering to the additional load of LPG Amine Treatment Unit.

B3.10. Statutory Clearance

1. Assistance in obtaining all statutory clearances including but not limited to PESO, CFE, EC, CEA, CEIG, IBR etc. required for the project including compilation and preparation of all necessary documentation, drawings, arrangement of statutory site / shop inspection etc. and getting final the approval.
2. Assistance in obtaining necessary statutory approval for Fire water system



**ENGINEERING, PROCUREMENT AND CONSTRUCTION MANAGEMENT (EPCM) SERVICES FOR
INSTALLATION OF LPG AMINE ABSORBER SYSTEM IN PFCC UNIT AT MRPL, MANGALURU**

3. Ensure Inspection of all lifting tools and tackles as required by statutory requirements and issue of relevant certificates from Competent Authority as the case may be, valid for one year from the date of mechanical completion.

C. Procurement Management

C.1. Procurement services as per the agreed Contract and Purchase (C&P) procedure finalized with MRPL shall include:

1. Preparation of Bid Evaluation Criteria, preparation of Estimate, issue of enquiry, tendering of all enquires / requisitions/ RFQs/NITs etc, receipt of bids, evaluation of bids, techno-commercial recommendations to MRPL, preparation of draft FOA / PO for final ordering by MRPL. Any change in agreed C&P procedure during execution needs approval of MRPL before initiation.
2. Conduct pre-bid meeting and provide clarifications to bidders as applicable.
3. Updation and finalization of GCC and SCC documents
4. Preparation of approved vendor list duly approved by MRPL.
5. Inspection, IRNs, dispatch instructions and expediting of delivery of indigenous equipment and materials.
6. Coordinating and monitoring activities of vendors, transporters, shipping agencies.
7. Inspection and expediting of imported equipment and material is excluded from the scope of Services. If required by MRPL, these services shall be provided by Consultant to MRPL on per-diem rate basis as per order. In case a third-party inspection agency is arranged, QA / QP submitted by the vendor shall be reviewed and approved by Consultant for its adequacy.
8. Procurement of short-supplied items and items as replacement of defective items.
9. Spares, Mandatory spares, Commissioning spares shall be received by Consultant stores and the spares handed over to MRPL's designated representative / store immediately on receipt as per mutually agreed procedure.
10. Recommendation on the performance of the vendors leading to closing of the contract.
11. Assist in Government Audit / Vigilance queries after completion of the individual contracts. This assistance shall be provided up to 2 years after mechanical completion of the facilities covered in this contract. Beyond this period, Consultant shall provide its services on per diem rate quoted in Form SP-1 subject to mutual acceptance.
12. Analyse applicability of PRS (Price Reduction Schedule) clause as per contract and recommendation of the same. Efforts to be made to give final recommendation on applicability of PRS, along with delay analysis, before Contractual completion date.
13. Custom clearance and material transport to site shall be by MRPL through their Clearing and forwarding agents. Consultant shall co-ordinate and assist for the same.
14. Certify vendor / Supplier / Contractor invoices.
15. Tendering services shall comprise:
 - a. Preparation of detailed tendering procedures.
 - b. Preparation of Bid evaluation criteria, SCC, list of subcontractors for MRPL approval as per C&P procedure provided by MRPL
 - c. Releasing/Floating of MRs/S Rs/RFQs/NITs, etc (either manual / e-tender) and as per C&P procedure
 - d. Receipt of Bids and safe custody of the same till finalisation of the Order



**ENGINEERING, PROCUREMENT AND CONSTRUCTION MANAGEMENT (EPCM) SERVICES FOR
INSTALLATION OF LPG AMINE ABSORBER SYSTEM IN PFCC UNIT AT MRPL, MANGALURU**

- e. Evaluation of tenders and recommendation to MRPL for opening of price bids for award of contract.
- f. Draft contract preparation and assistance in sorting out contractual problems during execution and assist in finalization of contracts.

C.2. Inspection

1. Consultant shall approve the QAP and prepare ITP for all indigenous equipment and materials.
2. Consultant shall undertake inspection of all indigenous equipment and materials and prepare IRN, dispatch clearance notes etc.
3. Consultant shall coordinate with vendors and suppliers for dispatch of equipment and materials and coordinate with the transporter for safe and early receipt of the same at site.
4. Items under the purview of authorities like Indian Boilers Regulations (IBR), Chief Controller of Explosives (CCE- PESO) and any other statutory bodies are excluded from Consultant's scope of inspection. However, documentation related activities shall be in the scope of the Consultant.
5. Inspection of imported equipment and materials is not considered in Consultant's scope of inspection. The inspection of these shall be in the scope of the approved Third-party Inspection agencies. However, the inspection reports shall be reviewed by Consultant before acceptance.

C.3. Expediting

1. Expediting services shall be provided for all purchase and service orders.
2. Expediting shall be carried out by way of shop visits for indigenous suppliers based on mutually agreed frequency with MRPL. Expediting visits for imported items and foreign orders shall be on per diem basis as per order.
3. On completion of order, an order closing report (OCR) shall be issued.

C4. Evaluation of Bids

1. Consultant shall carry out techno-commercial evaluation of bids and submit evaluation report with appropriate recommendation as per the approved bid evaluation criterion.
2. Consultant shall raise techno-commercial queries for getting required clarifications from the bidders and shall suitably resolve techno commercial queries raised by bidders.
3. Consultant shall arrange and participate in any meeting with bidders which may be required during bidding and evaluation period.
4. Consultant shall issue addendums, corrigendum and clarifications arising out of the pre bid meetings and discussions with bidders, replies to queries etc.

D. Construction Management and Supervision

The primary responsibility of construction management, front line supervision, cost control, quality assurance and control, health, safety and environment protection, warehouse management, material control and mechanical completion shall be with the Consultant.

D.1. Scope shall include but not limited to the following:

1. Organize, plan, monitor and manage construction work as a whole.
2. Fix and periodically review construction programs, time / billing schedules, targets etc. with construction agencies.
3. Identify construction infrastructure and resource requirement.



ENGINEERING, PROCUREMENT AND CONSTRUCTION MANAGEMENT (EPCM) SERVICES FOR INSTALLATION OF LPG AMINE ABSORBER SYSTEM IN PFCC UNIT AT MRPL, MANGALURU

4. Consultant shall plan, design and finalize temporary facility like fencing, hard barricading, construction power / water, lay down area etc. as per requirement of the project in consultation with MRPL.
5. Coordinate in conformity with plans, specifications and approved schedules. Liquidate all checklist points issued by statutory / regulatory bodies also, if any.
6. Liquidate all checklist points issued by Licensor / MRPL.
7. Arrange testing services for control of construction materials and methods and meet quality requirements. The cost incurred for such testing will be under the scope of the contractor.
8. Field engineering, supervision and inspection.
9. All safety precautions / requirements shall be ensured / followed.
10. Certify quality and quantity of work performed by contractors and maintain necessary records required for verifying contractor invoices. Analysing extra claims, if any and forwarding recommendations to MRPL.
11. Material reconciliation with the contractors and return of extra items / materials with valid test certificates to MRPL stores along with assistance in SAP codification for items / materials returned
12. Ensure statutory compliance such as PF, ESI, Insurance, Labour Cess etc. of contractors.
13. Checking of inventory.
14. All necessary services and site inspection for rectification of defective works.
15. Ensure disposal of scrap by contractors in designated area.
16. Process recoveries from contractors for issue of materials, hire charges, rents and taxes etc. as per provision of contracts and perform all duties of the Engineer-in-charge / Owner.
17. Technical assistance in expeditious settlement of extra claims, disputes etc.
18. Initiate action for arranging services of vendor's specialists as required for satisfactory execution of erection and mechanical trial run.
19. Assistance for arranging of contractors for various related services such as those required for receiving, movement, handling and transportation of materials.
20. Prepare construction Progress Reports, Construction Schedule, Action Plan and other applicable reports.
21. Review and certify as-built drawings prepared by respective contractors.
22. Technical assistance to MRPL in matters pertaining to local laws, labour and public relations.
23. Consultant shall inspect, audit and certify the compliances of all labour laws by the contractors including but not limited to payment of wages, PF, ESI and other labour related benefits.
24. Consultant scope also includes a study of the ODC consignments envisaged in the project and the roads leading to project site and make clear recommendations regarding the strategies to be followed in terms of shop fabrication or site fabrication or the routes to be followed for ODC consignments
25. Assist in settling disputes.
26. Prepare all documents including certification related document.
27. Warehouse Management: Receipt of materials, identification of short supply / defective items including assisting MRPL for lodging insurance claims, issue of materials to the contractors, reconciliation of materials and handing over the same to MRPL.



**ENGINEERING, PROCUREMENT AND CONSTRUCTION MANAGEMENT (EPCM) SERVICES FOR
INSTALLATION OF LPG AMINE ABSORBER SYSTEM IN PFCC UNIT AT MRPL, MANGALURU**

28. Assist in settlement of claims for period of 24 months beyond mechanical completion. Beyond this period CONSULTANT shall provide its services on mutually agreed per diem rate basis
29. Material Receipt Handling at site:
 - a. Receipt, handling, identification, inspection, acceptance, warehousing, storage and preservation of materials, material reconciliation, appropriation and handing over to MRPL as per agreed procedure.
 - b. Dispatch of free issue materials and inventory checks.
 - c. Segregation of scrap generated at site.
 - d. Recommendation for payment to the suppliers / transporters / material handling contractor / material preservation contractor.
 - e. Dispatch of free issue materials to contractors wherever applicable.
 - f. Return of balance materials to MRPL's stores with proper records.
 - g. Submit report on short supplied and defective items.
30. Shall abide by MRPL security and statutory requirements.
31. Consultant shall inspect, witness, review and certify work done by contractors including but not limited to weld records and field testing of all disciplines as per agreed QA plans. Records of rectification in case of unsatisfactory work not meeting / conforming with quality shall be maintained.
32. Suitable formats to be developed for QC, construction progress and Job / Work procedures.
33. For site inspection activities, Consultant shall ensure that
 - a. Contractors shall not proceed beyond identified witness tests and hold points without Consultant's clearance.
 - b. If it is observed that work is not conforming to specifications and drawings, Consultant shall ensure that remedial works are carried out.
 - c. In those situations, where continued work would cause damage, preclude further inspection, or make remedial action ineffective, and where there is no authorized representative of the contractor immediately available at the work location, Consultant's inspector responsible for that work shall stop the work in progress.
34. Further to the above, Consultant shall also undertake the following:
 - a. Welder qualification
 - b. Welding procedure finalization and approval
 - c. Welding inspection
 - d. Hydro testing
 - e. Review of radiography and interpretation of radio graphic films
 - f. Mechanical clearance
35. Monitor that the number of welds to be spot-checked is a true representation of the actual number of welds.
36. Check and monitor that the contractors maintain a proper up-to date documentation system of the radiographs, which can identify the location of the weld and the welder concerned.
37. Coordinate field instrument calibration and impulse line hydro testing
38. Coordinate with piping division for the installation of prefabricated hook-up.



ENGINEERING, PROCUREMENT AND CONSTRUCTION MANAGEMENT (EPCM) SERVICES FOR INSTALLATION OF LPG AMINE ABSORBER SYSTEM IN PFCC UNIT AT MRPL, MANGALURU

39. Undertake inspection of field inspection activities of civil and structural work, equipment installation, mechanical, piping, electrical work, instrumentation work, insulation, painting and fire proofing works at site and at contractor's fabrication yard
40. Coordinate and ensure the presence of vendor representative during the erection and commissioning of package units and equipment as required.
41. Coordinate and witness instrumentation loop checking and testing.
42. Coordinate and witness simulation of process / equipment interlocks from field.
43. Preparation and liquidation of check list of all disciplines.
44. Coordinate with Licenser / Contractor with respect to issue of check list for the system by licenser and liquidation of the same by contractor before the plant is accepted for mechanical completion.
45. Coordinate (for and on behalf of MRPL) with contractors for obtaining all the necessary statutory clearances required from CCE (PESO), OISD, IBR, CEA, CEIG and other statutory authorities as required.
46. Review all extra claims of the Contractors and submit recommendation to MRPL.
47. Consultant shall continue to provide Project related technical assistance services to Owner, as may be required for activities such as:
 - ❖ Extra claims of the Contractors / vendors for the project.
 - ❖ Disputes arising during the execution of the various contracts, for amicable settlement
 - ❖ Reply to queries from various auditing agencies Government Audit and statutory bodies, etc w.r.t Consultant deliverables.
 - ❖ Clarification in all litigations pertaining to the Project.
 - ❖ Insurance claims of Owner

Above mentioned assistance as shall be provided up to 2 years after mechanical completion of the facilities covered in this contract. Beyond this period Consultant shall provide its services on per diem rate quoted in FORM SP-1, subject to mutual acceptance.

D.2. Construction Safety

Consultant shall:

1. Form a safety cell comprising of qualified safety personnel to ensure that all safety regulations and procedures are followed at construction site.
2. Review safety procedures in accordance with applicable codes, regulations and client requirements and ensure adherence to safety norms.
3. Ensure that necessary precautions are taken to protect construction work and materials from damage by climate and site activities.
4. Ensure contractors obtain necessary approvals and permits for the construction activities, as per tender requirement.
5. Consultant shall enter into a safety pact with MRPL. A copy of the safety pact will be furnished to the successful bidder.

D.3. As-built Drawings and Documents

1. Documentation shall be checked for its correctness and completeness at the time of handing over of any plant / system / unit and recommended for taking over by MRPL.
2. Monitor and ensure that all as-built drawings are made, compiled and submitted by the contractors, vendors as per the agreed procedure.



ENGINEERING, PROCUREMENT AND CONSTRUCTION MANAGEMENT (EPCM) SERVICES FOR INSTALLATION OF LPG AMINE ABSORBER SYSTEM IN PFCC UNIT AT MRPL, MANGALURU

3. Ensure that final documentation including drawings generated from Consultant, as-built drawings, documents, field inspection documents, records, vendor documents, statutory drawings / documents are submitted as per final documentation procedure.

D.4. Mechanical Completion

1. Ensure a phased mechanical completion programme to facilitate sequential pre-commissioning activities culminating in a logical commissioning programme of various facilities required for the project.
2. Review formats of handing over including required documentation, construction completion certificates and mechanical completion certificates.
3. When the project is ready for commissioning, other than in respects as per discretion of Consultant, which do not prevent commissioning, major civil engineering is completed, equipment and machinery are installed and aligned, major services are completed, hook up with the required systems are completed, electrical / instrumentation installation works and testing are completed, punch list and check list points as defined by Consultant for Mechanical Completion are liquidated (FORMAT-3), Consultant shall notify MRPL in writing that the LPG Amine Treatment Unit is Mechanically Completed and ready for pre-commissioning activities and trial runs. The date of readiness for pre-commissioning as aforesaid shall be deemed to be the date of MECHANICAL COMPLETION for the purpose of this contract.

E. Pre-commissioning and Commissioning, Start up and PGTR assistance

1. Coordinate and provide technical assistance in pre-commissioning and commissioning and arrange for resolution of all technical problems that may arise in this process.
2. Pre-commissioning activities will include ensuring conformance to PFD / P&ID, flushing of lines with air, water, steam, nitrogen etc. as required, chemical cleaning of lines, leak test with air, nitrogen, process fluids etc. as per process Licensor recommendations and any other activity required to be carried out in pre-commissioning.
3. Tuning of all PID controllers, testing / commissioning of loops.
4. Assist MRPL for performance test of various units / packages and ensure that all contractual obligations are met.
5. Ensure implementation of necessary remedial measures (suggested by Licensor) through the concerned agencies (Contractors) in case of non-conformance to any of the guaranteed parameters.
6. Guarantee test runs shall be conducted by MRPL in the presence of Licensor.

F. Cooperation and Coordination with Process Licensors, Other Consultants, Contractors and Supplier

Shall cooperate with MRPL's other Consultants, Process Licensors, contractors and suppliers and provide reasonable access to Consultant's premises for them and coordinate its activities with the activities of such Consultants, Process licensors, contractors and suppliers.



SPECIAL CONDITIONS OF CONTRACT (SCC)

1.0 LOCATION AND ACCESS OF SITE :

1.1 The work site is located within MRPL Refinery complex, Mangaluru / Refer scope of work Exhibit- 2

2.0 Special Notes

1. General

- a. Special Conditions of contract shall be read in conjunction with the General Conditions of Contracts, specification of work, Drawings and any other documents forming part of this contract wherever the context so requires.
- b. Wherever it is mentioned in the specifications that the Consultant shall perform certain work, investigation, survey etc. or provide certain facilities, it is understood that the contractor shall do so at his own cost.
- c. The materials, design and workmanship shall satisfy the relevant Indian & International Standards, the job specifications contained herein and codes referred to. Where the job specifications stipulate requirements in addition to those contained in the standard codes and specifications, these additional requirements shall also be satisfied
- d. The Consultant shall strictly follow Housekeeping and Safety regulations in their area of work.
- e. The Consultant has to ensure use of skilled manpower and specialised proven methods and analysis used to carry out Job of this nature.
- f. The Consultant personnel shall maintain Good Discipline, Safety Standards, and Commensurate with Industrial standard. In the opinion of the Engineer-in-charge//OWNER, any of the contractor personnel is found unsuitable services of such personnel shall be discontinued and the consultant shall provide suitable alternate personnel immediately.
- g. Entry into the plant is restricted. Only pass and permit holders as also vehicles with special permits only are permitted within the boundary of the plant and port. Inside the premises, permits issued for each area also further regulate access to various work spots. The consultant to arrange for passes for their staff & subcontractor at their cost. Police verification of all personnel shall be required for issuing of Gate Pass at MRPL. Consultant shall arrange the Police verification for their staff and their subcontractors at their cost.
- h. Insurance of Consultants personnel, when working at site at MRPL Premises is in the scope of Consultant.
- i. All hiring charges for Services, Procurements, equipment, Tools, tackles etc. and other incidental expenditure required should be borne by the consultant.
- j. Consultant shall obtain all permissions at their cost, from private/public/local/government bodies and other authorities including providing safe and conducive working atmosphere for their personnel in advance for smooth implementation of the tendered work without any hindrance.



ENGINEERING, PROCUREMENT AND CONSTRUCTION MANAGEMENT (EPCM) SERVICES FOR INSTALLATION OF LPG AMINE ABSORBER SYSTEM IN PFCC UNIT AT MRPL, MANGALURU

- k. The Consultant may need, if required to execute the Job on Round the clock basis including Sundays & Holidays in order to complete the job within the specified time schedule.
- l. The Consultant shall submit Bar Chart showing the time schedule for various activities within seven days from the date of award of the contract.
- m. The Consultant may visit the site and acquaint himself fully of the site conditions and no additional/ Extra Claims, whatsoever, will be entertained on the plea of ignorance or for any difficulties involved during work.
- n. The charges quoted by the consultant shall include all the expenses towards travel (air/rail/road), lodging, boarding, local transport and other incidental expenses of the Consultant and all its personnel.
- o. The Consultant shall submit PBG within 15 days of award of PO/LOA an amount equivalent to 10% of the contract value interest free security deposit/ PBG towards due & satisfactory performance of the contract in the form of DD in favour of MRPL or in the form of Bank Guarantee as per MRPL standard Performa.

2. Work Program

- a. Consultant shall within 15 days after the Effective Date of Contract furnish to MRPL Structure & Mobilisation Plan for at all the Execution Centres including a detailed Work Program showing how Consultant shall perform the Work in accordance with the Time Schedule of Work (incorporating but not limited to all Milestones and Milestone Tasks in order to complete the work within the specified time).
- b. The project schedule shall be drawn in such a manner that it meets the requirement of the client. The project shall be monitored based on a control schedule, which will be 1 months ahead of contractual schedule.
- c. MRPL and Consultant shall thereafter settle such work program and such settled program signed on behalf of the MRPL and CONSULTANT shall constitute "Time Schedule of Work" or "Schedule of Work" for the purpose of the Contract.
- d. To complete the job as per schedule consultant shall mobilize additional manpower based on the actual requirement at consultant cost.

3. Approval of Program

- a. MRPL shall, within 15 days of receipt of such program, notify CONSULTANT in writing that:
 - i. The work program is approved with or without modification; or
 - ii. The work program is rejected, in which case reasons for such rejection shall be given;or
- iii. Further information is required to clarify or substantiate the work program.
- b. Provided that if none of the above actions is taken within the said period of 30 days, MRPL shall be deemed to have approved the program submitted. Consultant shall, within 15 days of receiving notification under (c), provide further information requested failing which the program shall be deemed to have been rejected.
- c. CONSULTANT shall within 7 days there-after submit a revised program taking account of the reasons given for the rejection or incorporating the further information requested by MRPL.
- d. After MRPL's approval of such detailed program, Consultant shall comply therewith, provided that such program may thereafter be modified with MRPL's prior, written consent.



ENGINEERING, PROCUREMENT AND CONSTRUCTION MANAGEMENT (EPCM) SERVICES FOR INSTALLATION OF LPG AMINE ABSORBER SYSTEM IN PFCC UNIT AT MRPL, MANGALURU

- e. MRPL shall have the right to request Consultant in writing to make any changes, modifications, deletions and / or additions to Consultant's scope of services.
 - f. Consultant shall work out and submit without undue delay, the estimate of price and time adjustment on account of such changes, modifications, deletion and/or additions sought by MRPL.
 - g. If MRPL does not agree to Consultant's reply to fore stated request or any part thereof, MRPL shall promptly notify Consultant in writing. Parties shall meet and discuss the same for mutual agreement at the earliest without jeopardizing the project activities. If such agreement is reached between Parties within 30 days from the date of such meeting / discussion, Consultant shall have the right not to incorporate such changes unless MRPL directs to proceed further in writing, pending such agreement.
4. **Priority of Work:** Consultant shall give the Work priority and no other work of Consultant shall take precedence over the Work, nor shall Consultant make any allocation of its resources which would have the effect of delaying the timely performance of the Work.
5. **Maintenance of Schedule of Work:** If Consultant is not performing the Work at a rate which will maintain the Schedule of Work, Consultant shall, at its expense and without entitlement to any additional compensation, cause Consultant's Personnel to work such overtime and shall furnish such additional personnel and other resources & inputs / materials as may be required to comply with the Schedule of Work.
6. **Adjustments of Schedule of Work:** Time Schedule of Work shall be adjusted only:
 - a. By an extension of time granted by the MRPL or
 - b. When the Parties otherwise agree in writing that the Time Schedule of Work should be extended or accelerated
7. **Definition of Mechanical Completion and Acceptance:** Mechanical Completion is the condition achieved when:
 - a. The Plant or facility has been erected in accordance with relevant drawings, documents, specifications, instructions and applicable codes and regulations, safety standards.
 - b. The work detailed as per scope of services has been completed. Consultant shall prepare a detailed list of services to be completed before MC and After MC for each discipline (Mechanical/Electrical/Process/Instrumentation/Critical Rotary/ Piping/ Inspection etc)
 - c. Punch list points as defined by Consultant for achieving Mechanical Completion are liquidated and FORMAT 3 is issued.
 - d. All the deficiencies that could prevent safe and orderly commissioning activities have been rectified.
 - e. Defined Tie-in work to the operating plant will be carried out prior to Mechanical Completion.
 - f. Balance punch list points, removal of scaffolding, temporary piping, and minor left out housekeeping can be done after mechanical completion but shall be completed before start up.
8. **General Guarantees and Defect Liability Period**
 - a. In the event of faulty or defective Process Design, Residual Process Design, HAZOP Study, Engineering Design Basis and/or review of detailed Engineering of the Plant/Unit and/or faulty approval of design(s), drawing(s) and specifications, including error or omission in the technical services or studies done, undertaken or performed by Consultant within the scope of Work described in tender, Consultant shall promptly and at its own cost and initiative carry out and undertake corrective studies, design(s),



ENGINEERING, PROCUREMENT AND CONSTRUCTION MANAGEMENT (EPCM) SERVICES FOR INSTALLATION OF LPG AMINE ABSORBER SYSTEM IN PFCC UNIT AT MRPL, MANGALURU

drawing(s) and engineering as may be necessary to rectify the fault or defect without any additional cost to MRPL. However, no such liability shall lie after expiry of Defect Liability Period, if the Performance Guarantees have been met.

- b. Defect Liability Period shall be after 18 months from date of mechanical completion or 12 months from the date of commissioning, whichever is earlier.
 - c. For the benefit of MRPL, Consultant shall include in Purchase Orders and Work Contracts a requirement for guarantees from equipment, materials vendors and Contractors against defects in materials and workmanship and shall assist OWNER in the enforcement of such guarantees. However, Consultant shall not be required to enter into any litigation with vendors / contractors on behalf of MRPL. Consultant shall ensure that the purchase specifications for all equipment and material adequately specify requirements of quality, process operating conditions/ working condition at site applicable codes and standards and special condition, if any. Consultant shall specify or undertake such tests and inspections as are normally required to ensure that all equipment and material to be procured, conform to the specifications and relevant codes and standards. Consultant shall ensure that the construction specifications for all works adequately specify the requirement of quality, working conditions at SITE, applicable codes and standards and special conditions, if any.
9. **Consequential Damages:** Neither party shall be responsible to the other for any penalty or consequential direct or indirect losses and damages such as loss of use of revenue, products or profits, increase cost of project like.
10. **Exclusion of Govt. of India's Liability:** It is expressly understood and agreed that the Owner will enter into this Contract solely on its own behalf and not on behalf of any other person or entity. In particular, it is expressly understood and agreed that the Government of India are not party to any such Agreement and will have no liabilities, obligation or right whatsoever hereunder. It is expressly understood and agreed that the Owner is an independent legal entity with power and authority to enter into Contracts solely on its own behalf under the applicable laws of India. Consultant expressly agrees, acknowledges and undertakes that the Owner is not an agent, representative or delegate of the Government of India and that of the Government of India are not and shall not be liable for any act, omission, commission breach or other wrong arising out of this Contract. Consultant hereby expressly waives, releases and forgoes any and all actions or claims, including cross claims, impleader claims or counter claims, against the Government of India arising out of any resultant agreement and covenants not to sue the Government of India for any manner of claim, cause of action or thing whatsoever arising out of or under any such Contract.
11. **Project Expediting Schedule:**
- i. Basic Engineering Design Package (BEDP) for LPG Amine Treatment Unit is placed on M/s. TECHNIP STONE AND WEBSTER by MRPL and will be handed over to successful bidder.
 - ii. Project Mechanical completion (including shutdown activities for the project) is scheduled for 24 months from issue of LOA.

3.0 CONSTRUCTION POWER & WATER (If APPLICABLE):

Construction Power for office purposes for Consultant's site office at MRPL site shall be provided by the MRPL free of cost. Water shall be arranged by Consultant at his own cost.



**ENGINEERING, PROCUREMENT AND CONSTRUCTION MANAGEMENT (EPCM) SERVICES FOR
INSTALLATION OF LPG AMINE ABSORBER SYSTEM IN PFCC UNIT AT MRPL, MANGALURU**

**4.0 PRICE REDUCTION SCHEDULE (PRS) FOR DELAYS IN EXECUTION OF CONTRACT
& PENALTIES:**

Refer EXHIBIT 4

5.0 DEFECT LIABILITY : Refer Exhibit-7

6.0 PAYMENT TERMS : Refer Exhibit-9

7.0 MANPOWER EMPLOYED BY BIDDER:

The Consultant shall without prejudice to his overall responsibilities and liabilities to provide adequate qualified and skilled personnel for the EPCM services as per tender and shall submit details along with their offer and shall deploy site organization and augment the same as decided by MRPL depending on the exigencies of work. Qualification and experience of key construction personnel shall be adequate as required for the EPCM services. In addition to this, Consultant shall deploy Safety Supervisors to ensure safer working conditions at site.

8.0 CONTRACT AGREEMENT:

The CONSULTANT shall execute a formal contract with OWNER within 28 days from the date of issue of Letter of Acceptance, on a non-judicial stamp paper of ₹.200/- value. The cost of non-judicial stamp paper shall be borne by the Consultant. Contract documents for agreement shall be prepared after the acceptance of bid. Until the final contract documents are prepared and executed, this Bidding Document together with the annexed documents, modifications, deletions agreed upon by the OWNER and bidder's acceptance thereof shall constitute a binding contract between the successful Bidder and the MRPL based on terms contained in the aforesaid documents and the finally submitted and accepted prices.

The Contract document shall consist of the following:

- a) Form of Contract on non-judicial stamp paper
- b) Original Bidding Document.
- c) Amendment to Bidding Document issued, if any.
- d) Fax/ Letter of Acceptance.
- e) Detailed Letter of Award (DLOA) along with enclosures.



**ENGINEERING, PROCUREMENT AND CONSTRUCTION MANAGEMENT (EPCM) SERVICES FOR
INSTALLATION OF LPG AMINE ABSORBER SYSTEM IN PFCC UNIT AT MRPL, MANGALURU**

SPECIFICATION FOR DOCUMENTATION REQUIREMENTS

[ANNEXURE – I TO SPECIAL CONDITIONS OF CONTRACT]



MRPL DOCUMENTATION PROCEDURE

1. Objective

- 1.1 This procedure provides general guidelines to compile and submit the Final Documents to MRPL by any agency executing a specific job against a Work Order or a Purchase Order issued by MRPL or by any agency on behalf of MRPL.
- 1.2 Final Document as per these guidelines shall be prepared ***in addition*** to the documents issued during project execution, which is normally released in piecemeal basis while the job is in progress.
- 1.3 This is a general guideline for all projects of MRPL; however any addition or deletion of the clauses based on the specific project requirement shall be approved by the PMC or the Engineer-in-charge of MRPL. An approved deviation note shall be furnished for this purpose.

2. Components of the Final Documents

2.1 Basic Design & Extended Basic Design Packages

Basic & Extended Design Packages shall be compiled and the revision control shall be complied and the revision control shall be maintained by the respective PMC or the similar agency of the project. At the completion of the project complete and updated sets of design packages with all latest revisions shall be handed over to MRPL.

2.2 Master Index for Documents & Drawings

- 2.2.1 These shall be treated as a key document for reviewing completeness of documentation at any point of time. It shall show details of documents / drawing applicable for any equipment / system / service. Master Drawing/Document Index shall have following columns:

Unit	Job No	Doc Folder No	Sr.No	Draw/ Doc No	Rev.	No. of Sheet	Equip.	Drawing Title	Remarks	
Revision						Date	Prepared by	Checked by	Approved by PMC/Consultant	Approved by MRPL

- 2.2.2 A detailed list of PO / Contract to be furnished to MRPL Engineering Documentation Centre to ensure that documentation of equipment / contract is/are submitted in totality.
- 2.2.3 A complete list of drawings and documents including document control index to be submitted ***in addition to clause 2.2.1.***

2.3 Sections of the final vendor / engineering document folder

2.3.1 Section A: Contents

Shall have following columns:

Sr. No	Drawing No	Rev	No. of Sheet	Equipment	Drawing Title	Digital File name(SOFT COPY)

This content or Master Index is to be certified by the Consultant / Engineer-in-charge of MRPL for its completeness in all respects.



**ENGINEERING, PROCUREMENT AND CONSTRUCTION MANAGEMENT (EPCM) SERVICES FOR
INSTALLATION OF LPG AMINE ABSORBER SYSTEM IN PFCC UNIT AT MRPL, MANGALURU**

2.3.2 Section B: Technical Documents / Drawings

An Approval Vendor Data Requirement Sheet (VDR) shall be obtained from PMC/ Engineer-in-charge of MRPL under following headings and drawings and documents shall be submitted accordingly.

B1 -Mechanical

B2 -Electrical

B3 -Instrumentation

B4 -Civil/Structural

B5 -Process Engineering

B6-Any Others

2.3.3 Section C: Inspection and test Records including IBR/Statutory certificates

2.3.4 Section E: As built drawings

In this section as built drawings for all site fabricated items, engineering drawings like process, piping, civil, electrical, instrumentation, plot plan, line schedules, pipe supports index/register, piping isometrics, firefighting etc. shall be compiled in an orderly manner.

1. The file format shall be labeled as mentioned in section 3
2. All as built drawings shall be approved by authorized signatory of (with sign & seal)

2.3.5 Section G: Digital Copy:

1. Two Sets of digital copies shall be submitted in CD/DVD with proper label. If size of the total files of a PO/Equipment is crossing more than 20 GB same to be submitted in external hard disk.
2. All Drawings shall be on the latest version of Auto CAD. If drawing is prepared in other format same need to be converted in to the latest Auto CAD version
3. Caesar II / PV Elite: Native files of engineering documents/drawings prepared using Caesar II / PV Elite shall be submitted in soft copies.
4. Hand Written/ filled test reports to be submitted in PDF format.
5. Radiography films preferably to be submitted in digital format.

2.4 Field Inspection Documentation

- 2.4.1 A detailed index to the content shall be available at the beginning of each file.
- 2.4.2 Each inspection reports shall be indexed with the report number and number of pages.
- 2.4.3 All Documents/Reports shall be approved in its totality by stamping & signing the Master Indexes as per section 2.2.1.
- 2.4.4 Radiography films shall be indexed and included with final documentation package.
- 2.4.5 All Radiographic films shall be put in an aluminum box/container with lock and key.
- 2.4.6 As Built drawings if any shall be compiled as per section 2.3.4
- 2.4.7 Digital Copy : as per clause no 2.3.5

3. File Format of Documentation Folder

- 3.1 **Filing:** As far as possible separate folder has to be prepared for each equipment / system / service, however if documentation for a particular equipment / system / service are required to be filed in more than one files due to the volume, identical folder no. suffixing numbers of files e.g. 1/5, 5/5 etc. shall be mentioned. On the other hand if the volume of documentation is less



**ENGINEERING, PROCUREMENT AND CONSTRUCTION MANAGEMENT (EPCM) SERVICES FOR
INSTALLATION OF LPG AMINE ABSORBER SYSTEM IN PFCC UNIT AT MRPL, MANGALURU**

COMPLETION CERTIFICATE OF FINAL DOCUMENTATION

Name of Supplier/Contractor :

Customer :

Project:

Project No :

Purchase Order No. /Contract No. :

Purchase Requisition No. / Tender No.: Rev. No. :

Name of the work/Equipment :

MRPL Equipment Tag. No:

Suppliers/ Contractors Works Order No :

No of Files:

Certified that the Engineering Documents / Manufacturing & Test Certificates submitted by the supplier are duly checked by us and found complete in all respect in accordance with the final documentation procedure no. SPC- 000009 and approved VDR (Clause 2.3.2)

Signature : Signature :

Date : Date :

Name : Name :

Designation : Designation:

Department : Department:

4.3 Piecemeal submission shall be avoided.

4.4 If any document / drawing is required to be submitted in later date after submission of final folder, shall clearly appear in the content (section 2.3.1) with a note "LATER" duly approved by PMC/Consultant/ Engineer-in-Charge.

4.5 Number of sets of final documents

Sr. No	Document Group	# Copies	Digital File
1	Basic/ Extended Design Packages	2	2
2	Vendor/Engineering Documentation/ Drawings(As – Built Final)	2	2
3	Final Field Inspection Reports (Drawings & Documents)	1	2



**ENGINEERING, PROCUREMENT AND CONSTRUCTION MANAGEMENT (EPCM) SERVICES FOR
INSTALLATION OF LPG AMINE ABSORBER SYSTEM IN PFCC UNIT AT MRPL, MANGALURU**

MANGALORE REFINERY & PETROCHEMICALS LTD.

CONTRACT WORKERS SAFETY POLICY

[ANNEXURE – II TO SPECIAL CONDITIONS OF CONTRACT]



**ENGINEERING, PROCUREMENT AND CONSTRUCTION MANAGEMENT (EPCM) SERVICES FOR
INSTALLATION OF LPG AMINE ABSORBER SYSTEM IN PFCC UNIT AT MRPL, MANGALURU**

Sr. no.	Topic	Page no.
1	SCOPE	3
2	REFERENCE	3
3	SAFETY REQUIREMENTS FOR CONTRACTORS	3
4	PERSONNEL	4
5	HEALTH AND HYGIENE	8
6	VEHICLE MOVEMENT	9
7	SAFE MEANS OF ACCESS	10
8	EXCAVATION, TRENCHING AND EARTH REMOVAL	11
9	DEMOLITION	12
10	PERSONAL PROTECTIVE EQUIPMENTS	13
11	PAINTING	14
12	LIFTING MACHINES TOOLS AND TACKLES	15
13	TEMPORARY SHEDS	16
14	ERECTION	17
15	WORK ON TALL CHIMNEYS	20
16	SAFETY OF ELECTRICAL WORKS	21
17	CATCH NETS	21
18	PROTECTION AGAINST MOVING VEHICLES	22
19	HANDLING MATERIALS	22
20	STACKING AND PILING	22
21	WELDING AND GAS CUTTING	22
22	GRINDING	23
23	HOUSE KEEPING	23
24	FIRE SAFETY	24



**ENGINEERING, PROCUREMENT AND CONSTRUCTION MANAGEMENT (EPCM) SERVICES FOR
INSTALLATION OF LPG AMINE ABSORBER SYSTEM IN PFCC UNIT AT MRPL, MANGALURU**

25	WORK PERMIT SYSTEM	24
26	WORK IN AND AROUND WATER BODIES	25
27	PUBLIC PROTECTION	25
28	OTHER STATUTORY PROVISIONS	25
29	GUIDELINES AND GENERAL PROCEDURES FOR SUPPLY AND USE OF ELECTRICITY AT SITE	26
30	PORTABLE ELECTRICAL EQUIPMENT	32
31	ROLE OF CONTRACTOR INCASE OF EMERGENCY AND SIREN	34
32	TRAINING	34
33	LIST OF PERSONAL PROTECTIVE EQUIPMENTS	34
34	MANDATORY FOR THE CONTRACTOR EMPLOYEES WHILE WORKING AT SITE	34
35	SPECIFICATIONS FOR SAFETY HELMETS-HDPE	35
36	SPECIFICATION FOR SAFETY BELT	35
37	SPECIFICATION FOR FALL ARRESSTOR DEVICE	36
38	SPECIFICATION FOR DUST MASK	36
39	SPECIFICATION FOR REPLACEABLE FILTERS	36
40	SPECIFICATION FOR SAFETY SHOES	36
41	STANDARD SPECIFICATION FOR PVC HAND GLOVES	36
42	SPECIFICATION FOR ELECTRICAL PPE (SHOCK PROOF)	36
43	TYPE SAFETY VIOLATIONS AND PENALTY SYSTEM	37



CONTRACT WORKER'S SAFETY POLICY

1. SCOPE :

This policy is applicable to all the contractors and their employees working in MRPL. This is also applicable to sub-contractors, suppliers, vendors and visitors. All the contractors are required to ensure that they and their employees comply with relevant safety requirements as mentioned in this Safety Policy depending on the nature of work. This policy is not a substitute to the statutory rules and regulations and also the prevailing MRPL Safety Requirements. This is to further reinforce the existing Safety Standards in Refinery.

2. REFERENCE : This document should be read in conjunction with following :

- General Conditions of contract (GCC)
- Special Conditions of Contract (SCC)
- Job specifications

3. SAFETY REQUIREMENTS FOR CONTRACTORS:

-Contractor shall furnish Safety policy and Safety Manual of their Company and his track record in safety for past three years to the Engineer Incharge.

Contractor shall furnish details of their safety department with CVs of safety officers in his bid document to Engineer Incharge.

-The contractor MUST employ Qualified Safety Officers as per the table below, having about 5 years of relevant experience in chemical units or Petrochemical Plants or refineries, as per The Factories Act 1948 / Building and other construction workers (Regulation of Employment and conditions of service) Act 1996 and Central Rules 1998 / The Karnataka Factories Rules 1969. Contractor shall ensure that all his workmen are aware about the nature of risk involved in their work and have adequate training for carrying out their work safely. Such Safety Officers appointed shall be dedicated and responsible only for safety. They should not be given any other responsibility. The contractor and his sub-contractor, if any, shall comply with the instructions given by MRPL Engineer In- Charge or his authorized nominee regarding safety precautions, protective measures, house-keeping requirements etc. Engineer-In-Charge from MRPL shall have the right to stop the work of the contractor, if in his opinion, proceeding with the work will lead to an unsafe and dangerous condition. Engineer-In-Charge shall get the unsafe condition removed or provide protective equipment at the contractors cost, whichever is applicable.



**ENGINEERING, PROCUREMENT AND CONSTRUCTION MANAGEMENT (EPCM) SERVICES FOR
INSTALLATION OF LPG AMINE ABSORBER SYSTEM IN PFCC UNIT AT MRPL, MANGALURU**

Table

Max. no. of employees < 30	One discipline (Engr. / Supervisor) with safety experience can function as Safety Staff on part time basis.
No. of employees : 30 – 100	One Safety Supervisor on full time responsibility.
No. of employees : 101 – 250	For Manpower Supply – Oriented Maintenance contract One Safety Supervisor on full time responsibility. For Service – Oriented Maintenance / Project contract One Safety Engineer on full time responsibility + One Safety Supervisor on full time responsibility
Upto 250 Persons deployed by him at site	Deploy one Safety Officer and additionally deploy Three Safety Supervisors
For 251 to 500 Persons	Two Safety Officers, Six Safety Supervisors and Ten Safety Stewards
For more than 500 persons	Three Safety Officers, Ten Safety Supervisors and Twenty Safety Stewards

Qualification criteria of safety officer:

BSc (Physics Chemistry only)/Diploma (Mech/Elect/Civil only) with post graduate Diploma in Industrial safety with min of 5 years experience in supervisory cadre.

OR

BE/BTech (Mechanical/Electrical/Civil only) with post graduate Diploma in Industrial safety with min of 2 years experience in supervisory cadre.

Qualification criteria of safety supervisor:

BSc (Physics Chemistry only)/Diploma (Mech/Elect/Civil only) with qualification in industrial safety with relevant experience.

4. PERSONNEL:

- Personnel / workmen (age 18 years & above) deployed at site should be physically / medically fit. Labours/workers shall not bring children/babies inside the refinery.
- SMOKING IS STRICTLY prohibited inside the refinery.
- Contractors and their workmen should restrict their activities to the site allocated to them.
- All contract men shall wear IS make PPEs like gloves, goggles, face shields, full body safety harness, safety belt, Safety Helmets, Safety Shoes etc during the work. They will not be permitted to enter the Refinery without wearing Safety Helmet, Safety Goggles & Safety Shoes. Damaged PPEs shall be taken out from use and disposed off properly.



**ENGINEERING, PROCUREMENT AND CONSTRUCTION MANAGEMENT (EPCM) SERVICES FOR
INSTALLATION OF LPG AMINE ABSORBER SYSTEM IN PFCC UNIT AT MRPL, MANGALURU**

- The contractor shall ensure that their men do not tamper with the facilities in operation. They shall not operate any Valves/ Switches etc.
- The contractor shall ensure that his workmen do not move around freely inside refinery premises other than the assigned place of work & also do not sleep anywhere (Below piperacks / equipments / trucks / etc.) inside refinery premises.
- The personnel engaged by the Contractor shall maintain good conduct and discipline commensurate with Industrial standard. If in the opinion of the Engineer-in-charge any of the personnel have not maintained good conduct and discipline, the Contractor shall remove such personnel immediately from MRPL premises and provide alternate personnel.
- The contractor Supervisors and Engineers must get themselves conversant with MRPL's Standard Operating Procedures (SOP), safety norms, Rules and Regulations that are in force. They must also be conversant with the MRPL's Emergency Procedures and Emergency telephone numbers and should ensure display of same at prominent place.
- Special safety precautions to be taken by the contractor or their personnel working in an operating refinery are given below. The safety procedure may undergo a change from time to time, which will be intimated to the contractor to follow and implement them.
- In addition to the following minimum safety requirements, the contractor must comply with the safety requirements, norms, rules and regulations as per the Factories Act 1948 and Karnataka Factories Rules 1969, OISD Guidelines 207 and other OISD standards / guidelines and Indian Standards.
- The contractor must prepare a detailed "Safety Programme" and submit it to Engineer In-charge of MRPL immediately after the finalization of contract / placing of LOI / order. This will include Safety Policy, Safety Responsibilities at various levels, Formations of Safety Committees and meetings, Method statements, Job Safety Analysis (JSA), Safety inspections, various pre-inspection checklists, Safety manuals, Safety Audits, Emergency Plans, Safety procedures to be implemented for all the activities, deputation of Safety Officers, enforcement of safety practices.
- Contractor shall devise a procedure on Accident Reporting. All accidents including Near Misses and property damages to be reported as per the MRPL's Accident Reporting Procedure in force. All Accidents including Near Misses to be communicated immediately to Engineer Incharge over telephone / verbally / and later submit the accident report. All accidents must be investigated, classified, analysed & comply with the recommendations to avoid its recurrence. Monthly Accident statistics must be developed and circulated. Contractor shall maintain a register of all such accidents.



ENGINEERING, PROCUREMENT AND CONSTRUCTION MANAGEMENT (EPCM) SERVICES FOR INSTALLATION OF LPG AMINE ABSORBER SYSTEM IN PFCC UNIT AT MRPL, MANGALURU

- During the mobilization, equipments, machines, tools, tackles etc. to be inspected at the site from where it is being mobilized. Damaged ones should be discarded and ensured not mobilized at MRPL site. The statutory checks, inspections and certification is carried out before mobilizing at MRPL site. Necessary repairs and maintenance to be carried out and equipment, machine, tools, tackles etc. is mobilized at MRPL site in working condition. The previous records of maintenance and the competent person's certificates to be made available during mobilization and submitted to MRPL Engineer Incharge. The equipments, machines, tools, tackles, etc to be tagged and mobilized.

- A Safety Committee must be formed to discuss accidents, Unsafe Acts and Unsafe conditions. This should be chaired by the High ranking Official / Site-In-Charge with equal participation both from supervisory and non-supervisory cadres of employees. Engineer In-Charge of MRPL also should be involved in such meetings as an observer. The frequency of meetings shall be once in a month minimum and actions taken to avoid recurrence of Nearmiss, Minor injuries etc.

Circular of the meeting must also be issued to MRPL Engineer Incharge at least one week in advance. Minutes of the meetings to be prepared on the same day and submitted on next day of the meeting.

The contractor shall take all safety precautions during the execution of awarded work and shall maintain and leave the site safe at all times. At the end of each working day and at all times when the work is temporarily, suspended, he shall ensure that all materials, equipment and facilities will not cause damage to existing property, personal injury or interfere with other works of the Refinery. The contractor shall comply with all applicable provisions of the safety regulations, clean up programme and other measures that are in force at the site.

- Safety Inspections of the site to be conducted daily and Safety Audits to be conducted once in three months by a team of Senior Officials of the contractor. Report on findings of such Audit to be submitted to the Engineer Incharge and compliance report of the suggestions on findings to be submitted weekly to Engineer Incharge.

Daily Safety Inspection of jobs and safety audit to be conducted every month and the report and protocol signed by all parties, Contractor's safety officers with signatures of Site Incharges of contractor shall be part of subsequent RA bill.

-Method statement along with Job Safety Analysis to be submitted at least 15 days in advance before starting of any activity.

Prior information of high risk jobs as planned shall be informed with short details of the work, job safety analysis report to the Engineer Incharge at least 48 hours before starting of such jobs.

High risk jobs like fabrication at height, lifting and shifting, erection of equipments etc shall be video recorded by the contractor.



ENGINEERING, PROCUREMENT AND CONSTRUCTION MANAGEMENT (EPCM) SERVICES FOR INSTALLATION OF LPG AMINE ABSORBER SYSTEM IN PFCC UNIT AT MRPL, MANGALURU

-The contractor shall provide and maintain all lights, guards, fencing, warning sign, caution boards, other safety measures and provide for vigilance as and where necessary or as required by the Engineer-In-Charge or by any duly constituted authority for the protection of workers or for the safety of others. The caution boards shall also have appropriate symbols visible during night also.

- Adequate lighting facilities, including emergency lighting, such as floodlights, hand lights and area lighting shall be provided along with ELCBs by the contractor at the site of work with isolation switch known to all at site with proper display, storage area of materials and equipment and temporary access roads within his working area. The contractor shall obtain written approval of the Engineer-In-Charge to the lighting scheme and place of tapping prior to its installation.

Use of devices like Distress alarm system for all personnel entering into confined space to be mandatory. Biometric attendance of personnel entering confined space should be maintained. Necessary Biometric punch machine to be arranged by the contractor at his own cost for this purpose. Staircases shall have temporary hand rail and guard till permanent handrails are fabricated and installed.

The contractor shall plan his operations so as to avoid interference with the other departmental works, other contractors or sub-contractors at the site. In case of any interference, necessary coordination shall be sought by the contractor from the Department for safe and smooth working. The contractor shall be held fully responsible for non-compliance of any of the safety measures, procedures and delays, implications, injuries, fatalities, property damage and environmental degradation and compensation arising out of such situations or incidents. The contractor should device a procedure to maintain head count of his personnel manually or with an installation of punching machine at site and ensure evacuation of his personnel through defined emergency exit in case if situation demands and also during confined space entry.

- Smoking is prohibited in the Refinery / work site / offices.
Consumption of alcohol and any other intoxicating material shall be also treated as safety violation and heavy penalty shall be levied on the main contractor.
- Radiography source and also the Explosives used for controlled blasting will not be permitted to be stored at site. Detailed accident report with photographs to be submitted to factory manager and Engineer In-charge from MRPL immediately.
- Contractor's Vehicles/Engines and approved electrical / mechanical equipments & lifting tools / tackles, welding generator that are to be used inside refinery are to be certified by competent authority. Statutory checks are to be carried out and records are to be maintained by contractors to ensure healthiness. These certificates will be regularly checked by MRPL engineer in-charge.



**ENGINEERING, PROCUREMENT AND CONSTRUCTION MANAGEMENT (EPCM) SERVICES FOR
INSTALLATION OF LPG AMINE ABSORBER SYSTEM IN PFCC UNIT AT MRPL, MANGALURU**

- The Contractor shall ensure that all industrial consumables such as Oxygen, Acetylene, Argon, Nitrogen, welding electrodes etc. are approved by MRPL, tested and records maintained by the contractor as per Gas Cylinder Rules before they are used for the job. LPG for gas cutting purpose is not allowed.
- The Fire prevention / protection and safety equipments (including Personal Protective Equipments) should be certified by MRPL engineer in-charge.

5. HEALTH AND HYGIENE:

- Sufficient number of toilets shall be provided by the contractor for its workmen and hygiene standard should be maintained.

Contractor to ensure no water stagnation at site.

Potable water facility for all workers shall be provided and maintained by the contractor.

Inspection of drinking water, sanitation, shall be done by MRPL. Availability of dust masks shall be ensured by the contractor at site.

Contractor to maintain affordable hygienic canteen for the workers.

- The contractor must maintain record of medical examinations of its employees as per The Factories Act 1948 and The Karnataka Factories Rules, 1969 and The Building and other construction workers (Regulation of Employment and conditions of service) Act 1996 and Central Rules 1998. This will include eye test of crane operators, vehicle drivers and all others. Also Fitness certificate by the Medical Officer for working at height to be produced for each employee requiring to work at height.
- Adequate means and personnel for rendering first aid should be readily available at site and during working hours at places where work is carried out.
- Medical aid for First-Aid should be available.
- First Aid kits or boxes, as appropriate, should be provided at the workplaces and on motor vehicles, cranes, etc. and be protected against contamination by dust, moisture, etc.
- When workers are employed underground or beneath structures or pits or other conditions in which they may need to be rescued, suitable rescue equipment like tripod with pulley and safety belt should be readily available at site at or near the work site along with trained rescue workers.



**ENGINEERING, PROCUREMENT AND CONSTRUCTION MANAGEMENT (EPCM) SERVICES FOR
INSTALLATION OF LPG AMINE ABSORBER SYSTEM IN PFCC UNIT AT MRPL, MANGALURU**

6. VEHICLE MOVEMENT:

- The contractor shall conduct his operation so as not to interfere with the use of existing roads at or near locations where the work is being performed.
- Speed limit inside the refinery is 16 KMPH which should be strictly followed. For heavy machinery like cranes / forklift / RMC trucks, etc. the speed limit is 5 KMPH maximum.
- Special precautionary measures should be taken during transportation of long sized cargo, route as defined should be followed and for safety of personnel (with proper escort) and damages to the facilities should be avoided. Procedure for vehicle entry and Speed limits in Refinery should be strictly followed. Vehicles and cargos passing through refinery should have PESO approved spark arrestor fitted.
- When interference to traffic is inevitable, notice of such shall be given to the Engineer- In-Charge of MRPL well in advance with the details of start of the work and time required, storage of materials, and details of the proposed methods of providing the required facilities for safe and continuous use of roads and obtain his clearance.
- The contractor shall exercise full care to ensure that no damage is caused by him or his workmen, during the operation, to the existing water supply, sewerage, power or telecommunication lines or any other services or works. The contractor shall be required to provide and erect before starting of the work, substantial barricades, guardrails and warning signs. He shall furnish, place and maintain adequate warning lights, signals etc, as required by the Engineer-In-Charge.
- Vehicles must have green red flags and whistles for the cleaner to guide driver. All vehicles entering MRPL premises shall have cleaner / helper.
- The vehicles must be maintained as per the preventive maintenance schedule of the manufacturer / supplier. Only Drivers that are trained in Defensive Driving shall be deployed inside Refinery
- Vehicles to be inspected fortnightly by trained technicians as per the inspection checklist. Pre-inspection checklist to be formed to that effect.
- All vehicles to bear a sticker. "If you notice this vehicle is over speeding then please inform on telephone no 08242882192 / 2191 / 2194 / 2771 / 2731".
- Tractors and trucks / cranes / forklift should not be used for transporting personnel.
- Every vehicle should have the contractor's name prominently displayed on Tractor Trolleys, trucks, jeeps, cranes, JCBs, Poclains, trailers. The display board should be put on front and rear side of each of the vehicle.



**ENGINEERING, PROCUREMENT AND CONSTRUCTION MANAGEMENT (EPCM) SERVICES FOR
INSTALLATION OF LPG AMINE ABSORBER SYSTEM IN PFCC UNIT AT MRPL, MANGALURU**

Tractor trolleys must have independent brake systems both on tractor as well as on trolleys.

- All vehicles must be fitted with PESO approved spark arrestors.

Tippers/trucks carrying debris and soil/mud/sand shall ensure that there is no spillage of material on road. If any such spillage observed the same need to be cleaned and cleared by the contractor immediately. Wheels of the trucks and vehicles shall be clean and free from mud.

- Contractor to maintain Inspection and maintenance logs for every vehicle.
- Any kind of repair work on contractor's vehicle is to be carried out only inside the work shop or designated place and not allowed inside the battery area or any where at on road or at site.

7. SAFE MEANS OF ACCESS :

- The contractor must possess adequate numbers of self retractable type fall arrestors (of different sizes viz. 6m, 20m, 40m, and 60m), Safety nets and Safety Belts (Full Body Safety Harness) (ISI approved).
- Adequate and safe means of access and exits shall be provided for all work places, at all elevations. Using of scaffolding members (avoiding a ladder) for approach to high elevation shall not be permitted.
- Suitable scaffolds shall be provided for workmen for all works that cannot be done safely from the ground, or from solid construction except such short duration work as can be done safely from ladders. Ladder shall be of rigid construction having sufficient strength for the intended loads and made of metal and all ladders shall be maintained well for safe working condition. If the ladder is used for carrying materials as well, suitable foot holds and handholds shall be provided on the ladder. Ladders shall not be used for climbing carrying materials in hands. While climbing both the hands shall be free. Ensure positioning of person at base / grade level while it is in use. All ladders, platforms, full body safety harness and safety nets should be inspected regularly and records should be maintained. Damaged items shall immediately be taken out of service and disposed off.
- Scaffolding staging more than 1.5 m above the ground or floor, swung or suspended from an overhead support or erected with stationary support and ladder shall conform to relevant IS specification. Timber bamboo scaffolding is not allowed inside the Refinery.
- Working platforms of scaffolds shall have toe boards 15cms in height to prevent materials from falling down.
- A sketch of the scaffolding proposed to be used shall be prepared and approval of the contractor's Mechanical Engineer obtained prior to start of erection of scaffolding. All scaffolds shall be examined and certified with proper display of tags by contractor's Mechanical Engineer before use.
- Safe means of access shall be provided to all working platforms and other elevated working places. Every ladder shall be securely fixed. No single portable ladder shall be over 9m in length. For ladders upto 3m in length the width between side rails in the ladder shall in no case



**ENGINEERING, PROCUREMENT AND CONSTRUCTION MANAGEMENT (EPCM) SERVICES FOR
INSTALLATION OF LPG AMINE ABSORBER SYSTEM IN PFCC UNIT AT MRPL, MANGALURU**

be less than 300mm. For longer ladders this width shall be increased by atleast 20mm for each additional metre of length. Step shall be uniform and shall not exceed 300mm.

- Working platform and gangway along the side of pipe racks shall be provided. Under no circumstance the contractor employees should step on pipes at pipe racks.

8. EXCAVATION, TRENCHING AND EARTH REMOVAL :

- A Work Permit must be taken for any excavation or earth removal inside the existing refinery premises from Engineer In-Charge MRPL, as the area of work has underground pipelines, cables etc.
- All trenches 1.2m or more in depth shall at times be supplied with at least one ladder for each spacing of 3.0m in length or fraction thereof. Ladder shall be extended from bottom of the trench to at least 1m above the surface of the ground.
- The sides of the trench which are 1.2m or more in depth shall be stepped back to give suitable slope (angle of repose) or securely held by timber bracing (i.e. shoring of the excavated trench or pit should be done), so as to avoid the danger of sides from collapsing. The excavated material shall not be placed within 2m of the edges of the trench or half of the depth of the trench, whichever is more. Cutting shall be done from top to bottom. Under no circumstances under-cutting shall be done.
- The contractor shall ensure the stability and safety of the excavation, adjacent structures, services and the works.
- Open excavations shall be fenced off by railing (ledger pipes) and warning signals installed at well-lit places so as to prevent persons falling into the excavations.
- All blasting operations shall be carried out on the basis of procedures approved by Inspector of explosives. All works in this connection shall be carried out as per IS code of practice. Barricades, Warning signs etc. shall be placed on the roads / open area. Prior approval of such operation shall be obtained from Engineer-In-Charge of works. The blasting procedure being followed by the contractor must be submitted with MRPL engineer in-charge.
- The contractor must submit the methodology, safety aspects, schedule, License and other relevant features of control blasting operations.
- Wherever manual removal of earth is involved, earth shall be removed from the top by maintaining the proper slope equal to the angle of re-pose of the earth. Manual removal of earth / lowering of person in a pit should be done with tripod and pulley besides use of Full body Safety Harness by person.
- Such work shall be constantly supervised by the contractor's responsible persons.



**ENGINEERING, PROCUREMENT AND CONSTRUCTION MANAGEMENT (EPCM) SERVICES FOR
INSTALLATION OF LPG AMINE ABSORBER SYSTEM IN PFCC UNIT AT MRPL, MANGALURU**

9. DEMOLITION:

Before any demolition work is commenced and also during the progress of the work :

- Proper approvals shall be taken from Engineer in-Charge MRPL before commencing demolition.
- Area around shall be barricaded with cautionary signs and posting of security guards or supervisors for preventing unauthorised entries of personnel.
- All roads and open area adjacent to the work site shall either be closed or suitably protected. Appropriate warning signs shall be displayed for cautioning approaching persons.
- No floor, roof or other part of the building shall be overloaded with debris or materials as to render it unsafe.
- Entries to the demolition area shall be restricted to authorized persons only.

Contractor to place separate collection facility of waste like metal, on metal non degradable and bio degradable wastes and shall dispose to designated place daily basis.

Contractor shall be responsible to clear dry grass and wooden items etc from and around his working site/storage/fabrication yard etc to prevent any fire accidents.

10. PERSONAL PROTECTIVE EQUIPMENTS:

- All proper "ISI" marked Personal Protective Equipments (PPEs) as considered necessary by the Engineer-In-Charge shall be kept available by contractor for the use of the persons employed on the site and maintained in a condition suitable for immediate use. Also the contractor shall take adequate steps to ensure proper use of equipment by those concerned. The PPEs are to be provided by the contractor.
- All persons employed at Refinery shall use safety helmets, safety shoes and safety goggles as minimum safety gears. For other types of works, persons working in that area shall also use the required PPEs, as advised by the Engineer-In-Charge of MRPL.
- Workers employed on mixing asphaltic materials, cement and lime mortars shall use Gumboots, safety goggles, hand gloves and proper respirator.
- Persons engaged in welding and gas-cutting works shall use suitable welding face shields with welder's helmet. The persons assisting the welders shall use suitable goggles. Protective goggles shall be worn while chipping and grinding.
- Stonebreakers shall use protective goggles. They shall be seated at sufficiently safe intervals or distance.
- Persons engaged in or assisting in shot blasting (Sand blasting is prohibited) operations and cleaning the equipment after shot blasting shall use suitable gauntlets, overalls, dust mask, dust proof goggles, safety shoes and protective hood supplied with fresh air.
- All persons working with 3M lifeline and hook at height above ground or floor and exposed to risk of falling down shall use safety belts (Full Body Safety Harness with double life line and scaffolding hooks, ISI marked) which should be properly secured to solid object unless



**ENGINEERING, PROCUREMENT AND CONSTRUCTION MANAGEMENT (EPCM) SERVICES FOR
INSTALLATION OF LPG AMINE ABSORBER SYSTEM IN PFCC UNIT AT MRPL, MANGALURU**

otherwise protected by cages, guard railings, etc. In places where the use of full body safety harness is impractical, suitable safety net of adequate strength fastened to substantial supports shall be employed under proper valid permit.

- When workers are employed in sewers and inside manholes, which are in use, the contractor shall ensure that the manholes are opened and are adequately ventilated at least for an hour. The atmosphere inside the space shall be checked for the presence of any toxic gas or oxygen deficiency and recorded in the confined space entry permit, availability of standby person at manhole must be ensured before the personnel are allowed to get into the man-holes. The manholes opened shall be cordoned off with suitable railing and provided with warning signals or caution boards or barricade tape to prevent accidents. There shall be proper illumination in the night.

11. PAINTING:

- Respirators shall be provided by the contractor for use when paint is applied, safety of personnel in vicinity also should be considered while painting.
- Overalls shall be supplied by the contractor to the workmen and adequate facilities shall be provided to enable the painters for decontamination at the cessation of work.
- All solvent-based paints, thinners shall be stored in separate well ventilated storage kept under proper surveillance.
- Smoking, open flames or sources of ignition / hot work shall not be allowed in places where paints and other flammable substances are stored, mixed or used. A caution board, with the instructions written in national / regional language, "SMOKING / HOT WORK – STRICTLY PROHIBITED" shall be displayed in the vicinity where painting is in progress or where paints are stored. Symbols shall also be used for caution boards.
- Suitable IS marked First Aid Fire Fighting equipments shall be kept available at a place where flammable paints are stored, handled or used.
- When painting work is done in a closed room or in a confined space, adequate ventilation shall be provided. Workers shall wear suitable supplied air type breathing apparatus. Work shall be carried out under a valid work permit.
- Epoxy resins and their formations used for painting shall not be allowed to come in contact with the skin. The workers shall use PVC gloves and / suitable barrier creams.
- Adequate ventilation shall be provided especially when working with hot resin mixes.
- Increased personal hygiene shall be practiced to control inadvertent contact with the resin and eliminate its effects.
- Workers shall thoroughly wash hands and feet before leaving the work. Work clothes shall be changed and laundered frequently.
- Care must be taken while carrying out painting inside confined space. There shall be safety devices to monitor the personnel working inside confined space like vessels during painting of internal surface. Suitable painting methods shall be adopted as specified elsewhere. It should not be clubbed with hot work and proper ventilation should be available to draw out the solvent vapours. Manual painting is to be adopted instead of spray painting.



12. LIFTING MACHINES TOOLS AND TACKLES:

- Supplier's / Manufacturer's manual for operations / safety / periodical maintenance of all Cranes, winches, JCBs, Poclains, Excavators, Trucks, tractors, Vehicles, etc. MUST be made available at site from the moment it is brought at site and the same should be strictly adhere to.
- Lifting machines, tools and tackles shall be of good mechanical construction, sound material, adequate strength, free from any defects and shall be kept in good working condition.
- Lifting machines, tools, tackles, equipments etc. to have identification tags of steel plate of size 2"x 2" tied to it using steel wire of 4 mm size. The details like reference number, Safe Working Load (SWL), date of testing, next due date of testing, etc. to be punched on this plate.
- Contractor must produce Competent Authority's (Authorised by The Directorate of Factories, Karnataka state) Certificate of testing in the prescribed form of Lifting Machines, Chains, ropes and lifting tackles well in advance. Only valid Lifting Machines, tools etc. to be used and to be re-certified before expiry of certificate. Also, these equipments will be inspected by Engineer In-Charge of MRPL as and when required. The same procedure is applicable for all other Electrical Equipments, tools, machines, D.G sets, compressors, etc.

Lifting equipments for testing by competent authority to include JCB, Poclain, Excavators, etc. The ringer crane to be tested and certified every time by Competent Person it is dismantled and reassembled. This certification must also include stability of soil on which it is assembled.

Use of Hydra is not permitted inside refinery/construction premises. Hydraulically jacked lifting machines to be used.

- Lifting machines, tools, tackles, equipments etc. to be inspected in addition to the Competent Authority's certification. This should be done fortnightly by experienced trained mechanical foreman and technicians and record of such inspection to be maintained.
- Every rope and sling used in hoisting or lowering of materials or as a means of suspension shall be of good quality and adequate strength and free from any defect.
- Every crane operator or lifting appliance operator shall have a driving License for Heavy Vehicle, proper physical fitness such as eye sight etc. and with adequate experience. No persons under the age of 21 years shall be in charge of any hoisting machine or give signal to operator of such machine.
- In case of every lifting machine (and of every chain, ring, hook, shackle, swivel and pulley block used in hoisting or as means of suspensions) the safe working load shall be ascertained and clearly marked. In case of a lifting machine having a variable safe working load, each safe working load and the conditions under which it is applicable shall be clearly indicated. No part of any machine or any gear referred to above in this paragraph shall be loaded beyond the safe working load.
- The contractor shall notify the safe working load of the machine to the Engineer-In- Charge whenever he brings any machinery to site for work and get it verified by the Engineer-In-Charge, supported by a valid test certificate by the competent person.



ENGINEERING, PROCUREMENT AND CONSTRUCTION MANAGEMENT (EPCM) SERVICES FOR INSTALLATION OF LPG AMINE ABSORBER SYSTEM IN PFCC UNIT AT MRPL, MANGALURU

- Motors, gearing transmission, couplings, belts, chain drives and other moving parts of hoisting appliances shall be provided with adequate safeguards. Hoisting appliances shall be provided with such means as to reduce to the minimum risk of any part on a suspended load becoming accidentally displaced or lowered.
- The contractor must have a team of Experienced Mechanical Personnel (having minimum of 5 yrs. experience in carrying out safety inspection and testing of Lifting machines, Tools and Tackles etc.), to conduct periodical (Daily, fortnightly, monthly and quarterly) inspection and testing of Lifting machines, Tools and Tackles and to maintain its records.
- Crane shall not be used as hoist. In case cranes are used as hoist then factory Inspector's permission to be taken in advance and to be subject to biannual testing by competent person as required for hoist under Factories Act 1948. Also, the design of cage to be got approved by the competent person well in advance. Two ropes or chains to be provided to the cage, separately connected with the cage, suspended independently and capable of carrying the whole weight of the cage.
- Contractor to maintain operation, inspection and maintenance logs for every lifting equipment, tool and tackle.

13. TEMPORARY SHEDS :

- Before erecting temporary shelters like sheds or tents anywhere at site, written permission of the concerned Engineer In-charge must be obtained.
- Temporary sheds for site office should be avoided. Instead contractor shall arrange for portal cabins for site office / stores.
- Temporary shed should not be erected using scaffolding pipes. The shed should be made of safe construction material.
- The temporary shed should be erected after proper designing following engineering design practices in conformance with normal safety standards to ensure the stability and safety.
- Temporary shed should bear the contractor's name.
- Temporary piping, hose connections and electrical wiring to these temporary sheds must be laid in such manner that they do not cause tripping, hitting or electrocution hazards.

14. ERECTION:

- At the planning stage consideration should be given, by those responsible for the design, to the safety of the workers who will subsequently be employed in the erection of such structures. A detailed erection scheme / schedule shall be furnished well in advance for all the critical erections.
- Care should be exercised by design engineers and other professional persons, not to include anything in the design which would necessitate the use of unwarrantably dangerous structural procedures and undue hazards, which could be avoided by design modifications.
- Facilities should be included in the design for such work to be performed with the minimum risk.



**ENGINEERING, PROCUREMENT AND CONSTRUCTION MANAGEMENT (EPCM) SERVICES FOR
INSTALLATION OF LPG AMINE ABSORBER SYSTEM IN PFCC UNIT AT MRPL, MANGALURU**

- Detailed Safety Procedure should be submitted as a part of Heavy Equipment erection scheme. Heavy Equipment erection scheme must be submitted at least one month in advance.
- Erection engineer to conduct training on rigging before every heavy lift / erection for crane operator, foreman and riggers.
- Erection of structural platforms, gratings and hand rails to be done on priority. The procurement of gratings, structural members for hand rails to be done on priority.
- Prefabricated parts should be so designed and made that they can be safely transported and erected.
- As far as practicable the safety of prefabricated parts while erection should be ensured by appropriate means, such as provision and use of:
 - a) Ladders;
 - b) Gangways;
 - c) Fixed platforms;
 - d) Platforms, Buckets, boatswain's chairs, etc. suspended from lifting appliances;
 - e) Safety belts and lifelines; and
 - f) Safety nets or catch platforms.
- Ladders to be inspected fortnightly by experienced trained mechanical foreman and mechanical technicians and record of such inspection to be maintained.
- The boatswain's chairs/ platforms used in structural erection to be inspected and checked once in fortnight and record maintained.
- In addition to the conditions of stability of the part when erected, when necessary to prevent danger the design should explicitly take into account:
 - a) The conditions and methods of attachment in the operations of stripping, transport, storing and temporary support during erection; and
 - b) Methods for the provision of safeguards such as railings and working platforms, and, when necessary, for mounting them easily or prefabricated parts.
- The hooks and other devices incorporated in prefabricated parts that are required for lifting and transporting them should be so shaped, dimensioned and positioned as:
 - a) To withstand with a sufficient margin the stresses to which they are subjected; and
 - b) Not set up in the part stresses that could cause failures, or stresses in the building not provided for in the plans.
- Prefabricated parts made of concrete should not be stripped before the concrete has set and hardened sufficiently to ensure the safety of the operation.
- Store places should be so constructed that:
 - a) There is no risk of prefabricated parts falling or overturning; and



**ENGINEERING, PROCUREMENT AND CONSTRUCTION MANAGEMENT (EPCM) SERVICES FOR
INSTALLATION OF LPG AMINE ABSORBER SYSTEM IN PFCC UNIT AT MRPL, MANGALURU**

- b) Storage conditions generally ensure stability having regard to the method of storage and atmospheric conditions.
- Prefabricated parts made of concrete should not be erected before the concrete has set and hardened to the extent provided for in the plans.
 - While they are being stored, transported, raised or set down, prefabricated parts should not be subjected to stresses prejudicial to their stability.
 - Trailers only to be used for transportation of pipes. Crane to be used for erection at site.
 - Every lifting appliance should :
 - a) Be suitable for the operation; and
 - b) Be approved by a competent person, or tested under a roof load 20 percent heavier than the heaviest prefabricated part.
 - c) Ringer mode of a heavy crane MUST be inspected, checked and certified by competent person every time it is dismantled and erected. The report must bear the stability of the soil on which it is erected.
 - Lifting hooks should have the maximum permissible load marked on them.
 - Tongs, clamps and other appliances for lifting prefabricated parts should:
 - a) Be of such shape and dimensions as to ensure a secure grip without damaging the part; and
 - b) Be marked with the maximum permissible load in the most unfavourable lifting conditions.
 - Prefabricated parts should be lifted by methods or appliances that prevent them from spinning accidentally.
 - The temporary basket cages / Platforms / Buckets / boatswain's chairs, etc. used for lifting / working at height suspended from lifting appliances or suspended from structures or beams MUST be certified by competent person and provisions or conditions as stipulated during certification to be adhere to.
 - While prefabricated parts are being lifted measures should be taken to prevent workers from being struck by objects falling from a height and area around such site should be barricaded with cautionary signs.
 - When necessary to prevent danger, before they are raised from the ground, prefabricated parts should be provided with safety devices such as railings and working platforms to prevent falls of persons.
 - If workers are exposed to danger when releasing prefabricated parts from lifting appliances, adequate safety measures should be taken.



**ENGINEERING, PROCUREMENT AND CONSTRUCTION MANAGEMENT (EPCM) SERVICES FOR
INSTALLATION OF LPG AMINE ABSORBER SYSTEM IN PFCC UNIT AT MRPL, MANGALURU**

- At workplaces adequate instructions should be given to the workers on the methods, arrangements and means required for the construction, storage, transport, lifting and erection of prefabricated parts.
- When it is not practicable to install protective guardrails and toe boards the workers should be provided with and use safety belts and lifelines to limit the height of the fall.
- Overhead screens to be provided to prevent workers from being struck by falling objects.
- The safety devices (guard-rails, toe-boards, safety belts and lifelines) should not be removed so long as the risk remains.
- Precautions should be taken to prevent fires being caused by rivet-heating equipment.
- Rivet heaters should extinguish their fires before leaving work.
- Extra care should be taken to prevent fall of objects, tools, etc. from height.
- Before structural steel parts are lifted, care should be taken that any object that could fall is fastened or removed.
- Structural steel parts should not be dragged while being lifted if that could cause danger.
- Steel trusses that are being erected should be adequately shored, braced or guyed until they are permanently secured in position.
- While structural members are being moved into place the load should not be released from the hoisting rope until the members are securely fastened in place.
- Structural members should not be forced into place by the hoisting machine while any worker is in such a position that he could be injured by the operation.
- No load should be placed on open-web steel joists until they have been placed in position and secured.
- Erection of pipes to be done using web belts only. Web belts must be inspected and checked fortnightly internally by the contractor and records maintained. Damaged ones to be cut to pieces and record to be maintained.
- Nipples and other accessories used for hydrotest and subject to high pressures to be inspected, checked and tested by experienced trained mechanical foreman and mechanical technicians and records maintained. Damaged parts to be replaced immediately with the new ones.
- Discarding criteria of web belts to be procured from the supplier / manufacturer by the contractor and submitted to MRPL Engineer Incharge.

15. WORK ON TALL CHIMNEYS:

SCAFFOLDS :

- All workmen should be certified medically fit by medical practitioner before working at height. Mock up drills MUST be conducted by the contractor for all these workmen and issue Working at Height passes to only those who has experience of working at height, is declared medically fit and shows confidence during mock up drills.



**ENGINEERING, PROCUREMENT AND CONSTRUCTION MANAGEMENT (EPCM) SERVICES FOR
INSTALLATION OF LPG AMINE ABSORBER SYSTEM IN PFCC UNIT AT MRPL, MANGALURU**

- For the erection and repair / painting of tall chimneys and vertical structures scaffolding should be provided. Scaffolds after erection should be certified by competent mechanical engineer for its strength before use and be displayed with a tag "Certified for use".
- Scaffolds should conform to relevant Indian Standards. Contractor MUST have a team of trained scaffolders including trained Scaffolding engineer.
- Fixed inside scaffolding should be securely anchored in the chimney wall.
- The scaffold floor should always be at least 65 cm (26 in) below the top of the chimney.
- Under the working floor of the scaffolding the next lower floor should be left in position as a catch platform.
- Suspended outside platform (inspection scaffolds) should be provided as per the relevant standards as stated above.
- Use of Catch platforms, stairs, ladders and Iron rung, lifting tools, tackles and work with hot asphalt, tar should be carried out as per the procedures outlined in relevant ILO manual.
- Full Body Safety Harness (Safety Belt) with lifelines (of various sizes 2', 5' and 9' double lanyards) and safety nets being used should conform to relevant standards and are to be inspected, tested, periodically and records be maintained. Damaged safety belts and nets should be discarded, taken out of service and disposed off.
- Safety belts must be used while working at height. The life lines (lanyard) MUST be tied to firm support. In case of absence of firm support provision of wire rope of adequate size tied with lifting tackles to be made to tie the safety belt life line (lanyard).
- All Safety belts to be inspected once in a month and damaged ones to be discarded. Suppliers / Manufacturers Discarding criteria of safety belts to be submitted to MRPL. The record of inspection and the results to be maintained. And a copy to be submitted to Engineer Incharge.
- The scaffolds to be inspected and certified by the competent mechanical Engineer before use and subsequently, at least once in a week.

16. SAFETY OF ELECTRICAL WORKS:

Before starting work in live electrical panels, proper electrical isolation shall be ensured. The same to be inspected by the electrical in charge and necessary isolation tag shall be attached. Proper electrical isolation permit system along with LOTO (Locking Out / Tagging Out) system shall be maintained by the contractor. Triplicate copy of such permits shall be submitted to MRPL.

17. CATCH NETS:

- Where workers cannot be protected against falls from heights by other means they should be protected by catch nets.
- Catch nets should be made of good quality fiber cordage, wire or woven fabric or material of equivalent strength and durability.
- The perimeter of catch nets should be reinforced with cloth-covered wire rope, manila rope or equivalent material.



**ENGINEERING, PROCUREMENT AND CONSTRUCTION MANAGEMENT (EPCM) SERVICES FOR
INSTALLATION OF LPG AMINE ABSORBER SYSTEM IN PFCC UNIT AT MRPL, MANGALURU**

- Catch nets should be provided with adequate means of attachment to anchorage.
- Catch nets to be inspected fortnightly, tested and records maintained. Damaged safety nets should be discarded and record maintained.

18. PROTECTION AGAINST MOVING VEHICLES:

Workers who are regularly exposed to danger from moving vehicles should wear;

- a) Distinguishing clothing, preferably bright yellow or orange in colour; or
- b) Devices of reflecting or otherwise conspicuously visible material.

Light Vehicle shall have reverse horn and Heavy Vehicles shall have trained helpers with whistle and red and green flags for directing the driver.

19. HANDLING MATERIALS:

- Mechanical means should be provided and used for lifting and carrying loads.
- Personnel should have knowledge of safe ways of material handling.

20. STACKING AND PILING:

- Materials and objects should be so stacked and unstacked that no person can be injured by materials or objects falling, rolling, overturning, falling apart or breaking.
- Area earmarked for stacking and piling should be barricaded and only authorised personnel be allowed to carry out stacking and piling jobs.
- Proper stacking and piling should be done as per the guidelines of ILO.

21. WELDING AND GAS CUTTING:

- Welding and gas cutting operations shall be done only by qualified and authorised persons and as per IS specification and code of practice.
- All the hoses used on compressed gas cylinders (Acetylene, Oxygen etc.) to be as per IS.
- Welding and gas cutting shall not be carried out in places where flammable or combustible materials are kept and where there is danger of explosion due to presence of flammable / gaseous mixtures. Contractor shall continuously monitor the area with Explosimeter / H₂S meters.
- Welding and gas cutting equipments including hoses and cables shall be maintained in good condition. It should be checked daily by the user and fortnightly by the supervisor and recorded.
- Barriers shall be erected to protect other persons from harmful rays from the work. When welding or gas cutting is done in elevated positions / on trenches / inside refinery units, precautions shall be taken to prevent sparks or hot metals falling on persons or flammable materials (Welding booths shall be constructed).



**ENGINEERING, PROCUREMENT AND CONSTRUCTION MANAGEMENT (EPCM) SERVICES FOR
INSTALLATION OF LPG AMINE ABSORBER SYSTEM IN PFCC UNIT AT MRPL, MANGALURU**

- Use of proper PPEs by personnel involved in Gas cutting / Electric Arc welding should be ensured. Use of Welders Helmet with face shield by the welders is a MUST.
- Fire extinguisher shall be available near the location of welding operations. Valid permit shall be obtained before flame cutting / welding is taken up & comply with all the permit requirements.
- Contact of personnel with the electrode or other live parts of electric welding equipment shall be avoided.
- Extreme caution shall be exercised to prevent accidental contact of electrodes with ground.
- The welding cables shall not be allowed to get entangled with power cables. It shall be ensured that movement of materials does not damage the cables.
- Oxy-Acetylene cylinders must be mounted on trolley with chain holding the compressed gas cylinders. The compressed gas cylinders must have pressure gauges fitted over it and Oxy-Acetylene Gas cutting set should be fitted with flash back arrestor at both the torch and cylinder ends.
- Under no circumstance the compressed gas cylinder should be taken inside the confined space or excavated pits. Hydraulic test certificates of all compressed gas cylinders should be maintained and furnished as and when required.

22. GRINDING:

- All portable grinders shall be used only with their wheel guards in position to reduce the danger from flying fragments should the wheel break during the use.
- Grinding wheels of specified diameter only shall be used on a grinder – portable or pedestal- in order not to exceed the prescribed peripheral speed.
- Helmet with face shield shall be used during grinding operation.

23. HOUSE KEEPING:

The contractor shall at times keep his work spot, site office and surroundings clean and tidy from rubbish, scrap, surplus materials and unwanted tools and equipment.

- Welding and other electrical cables shall be routed as to allow safe traffic by all concerned.
- No materials on any of the sites of works shall be so stacked or placed as to cause danger or inconvenience to any person or the public. The Engineer-In-Charge may require the contractor to remove any materials which, are considered to be of danger or cause inconvenience to the public.
- At the completion of the work, the contractor shall have removed from the work premises all scaffoldings, surplus materials, rubbish and all sheds and sanitary arrangements used / installed for his workmen on the site.
- House keeping of the workplace shall be done strictly by the Contractor on daily basis or as required by the Engineer-in-charge. Contractor to collect all debris/ scrap and dump at designated Scrap Yard as defined by MRPL authorities.



**ENGINEERING, PROCUREMENT AND CONSTRUCTION MANAGEMENT (EPCM) SERVICES FOR
INSTALLATION OF LPG AMINE ABSORBER SYSTEM IN PFCC UNIT AT MRPL, MANGALURU**

- A separate house keeping team to be formed and made available round the clock.

24. FIRE SAFETY:

- Adequate number of duly calibrated Explosimeters, Oxygen meters, Hydrogen Sulphide detectors (Portable / Fixed) or any other multiple gas detector should be made available at site by the contractor.
- Combustible materials like timber, bamboos, paints etc. shall not be used at MRPL site for scaffolding or for supports.

Containers of paints, thinners and allied materials shall be stored in a separate room, which shall be well ventilated, and free from excessive heat, sparks, flame or direct rays of the sun. The containers of paint shall be covered or properly fitted with lid shall not be kept open except while using.

- Fire extinguishers as approved by Engineer-In-Charge shall be located at the work site at appropriate places.
- Adequate number of contract workmen shall be given education and training in fire fighting and extinguishing methods.

25. WORK PERMIT SYSTEM:

- MRPL's Work Permit system (As per MRPL Safety Manual) to be strictly followed.
- All jobs within refinery should be executed with a safety work permit only. These will be issued by the concerned operating personnel of MRPL (Refinery Shift Manager or any authorised person). However, he can withdraw the permit when the stipulated conditions are not complied with at the work spot.
- Area is safe for performing the Work. Job is continuously supervised by qualified supervisor.

Responsibility of Performing Authority:

To obtain an approved Work Permit duly filled and signed by authorities as per the MRPL's Work Permit System before starting the work in the area.

- To visit job sites and ensure that it is prepared accordingly.
- The person performing the job shall be in possession of the permit till the completion of the job. The permit should be produced for inspection at any time. The Work Permit shall be displayed at job site in the plastic folder.
- To understand the scope of the work and implications involved.
- To restrict the work to the area / equipment specified in the work permit.
- To comply with the instructions given on the Work Permit.
- To follow Plant Safety Rules and Procedures.
- To be alert at all times for the development of unexpected situations.



**ENGINEERING, PROCUREMENT AND CONSTRUCTION MANAGEMENT (EPCM) SERVICES FOR
INSTALLATION OF LPG AMINE ABSORBER SYSTEM IN PFCC UNIT AT MRPL, MANGALURU**

To stop the work immediately on detecting any unsafe condition and promptly inform the Issuing Authority. Follow MRPL's Onsite Disaster Management Plan (DMP).

- To return the Permit duly signed after completion of the job to the Issuing Authority. Contractor must adhere to work permit system and other safety regulations.

26. WORK IN AND AROUND WATER BODIES:

When the work is done near any place, where there is a risk of drowning, all necessary rescue equipment such as life buoys and life jackets shall be provided and kept ready for use and all necessary steps taken for prompt rescue of any person in danger and adequate provision shall be made for prompt first-aid treatment of all injuries likely to be sustained during the course of the work. Persons who do not know swimming shall not be engaged alone for any work where risk of drowning exists. Sufficient number of life buoys or life jackets shall be provided.

27. PUBLIC PROTECTION:

The contractor shall make all necessary provisions to protect the public. He shall be bound to bear the expenses for defense of every action or other proceedings of law that may be brought by any person for injury sustained owing to neglect of any precaution required to be taken to protect the public. He shall pay the damage and cost which may be awarded in any such suit, action or proceedings to any such person, or the amount which may be fixed as a compromise by any such person.

28. OTHER STATUTORY PROVISIONS:

Notwithstanding the above clauses there is nothing in these to exempt the contractor from the provisions of any other Act or Rules or Indian Standards or OISD standards or OISD guidelines in force in the Republic of India. In particular all operations involving the transport, handling, storage and use of explosives shall be as per the standing instructions and conform with Indian Explosives Act, 1884 and the explosives Rules, 1983. The Factories Act 1948 and The Karnataka Factories Rules, 1969, Handling, transport, storage and use of Compressed gas cylinders and Pressure vessels shall conform with the Gas Cylinders rules 1981 and Static and Mobile pressure Vessels (Unfired) Rules 1981. In addition, The Building and other construction workers (Regulation of Employment and conditions of service) Act 1996, The Indian Electricity Act, 1910 and Indian Electricity Rules 1956, The Atomic Energy Act 1962, The Radiation Protection Rules 1971, Radiation Protection Manual of Nuclear Facilities and the Atomic Energy (Factories) Rules 1988 and various rules and Act relevant to the activities being performed shall also be strictly complied with.

- No Child labour should be brought in for work.
- MRPL holds the right to issue warnings / Heavy penalties (monetary fine) / suspend work at any time or terminate the contract for a loss / damage and a pattern of frequent failure to adhere to Safety Laws, regulations and Onsite Safety procedures. In general a heavy monetary fine will be deducted straight from the contractor's bill for each violation of Safety Rules / Unsafe Act / Unsafe Condition observed, for each First-Aid injury, for each Lost Time injury / Near Miss Accident and for each fatality.



29. GUIDELINES AND GENERAL PROCEDURES FOR SUPPLY AND USE OF ELECTRICITY AT SITE:

Following safety requirements shall be complied with before the contractor uses the power supply.

- The contractor shall submit a list of licensed electrical staff to be posted at site.
- It shall be the responsibility of the contractor to provide and maintain complete installation on the load side of the supply point with regard to the safety requirements at site. All cabling and installation shall comply with the appropriate statutory requirements given below and shall be subject to approval of the Departmental Engineer-In-Charge / Electrical Engineer.
 - a) Indian Electricity Act, 1910
 - b) Indian Electricity Rules, 1956
 - c) National Electric code, 1985
 - d) Other relevant rules of Local bodies and Electricity Boards.
- Where distribution boards are located at different places the contractor shall submit schematic drawing indicating all details like size of wires, overhead of cable feeders, earthing etc. The position and location of all equipment and switches be given.
- The contractor shall make his own arrangements for main earth electrode and tapings thereof. The existing earth points available at site can be used at the discretion of the Departmental Electrical Engineer with prior permission. Method of earthing, installation and earth testing results shall conform to relevant I.S. Specifications.
- Overhead High Tension (HT) cable routes to be marked and physically barricaded to prevent crane coming in contact with it.
- All three-phase equipment shall be provided with double earthing. All light fixtures and portable equipment shall be effectively earthed to main earthing.
- All earth terminals shall be visible. No gas pipes and water pipes shall be used for earth connection. Neutral conductor shall not be treated as earth wire.
- Every electrically operated machine or equipment to be independently earthed.
- Earth pits to be provided near DG sets, electrically operated machines, equipments etc.
DG sets used in Refinery shall be installed inside acoustic enclosure to minimise noise pollution. Exhaust of DG sets shall be routed to safe height.
- Continuity and resistance of all earth connections to be inspected and checked and tested fortnightly and records to be maintained.
- The contractor shall not connect any additional load without prior permission of Departmental Electrical Engineer.
- Joints in earthing conductors shall be avoided. Loop earthing of equipment shall not be allowed. However, tapings from an earth bus may be done.



**ENGINEERING, PROCUREMENT AND CONSTRUCTION MANAGEMENT (EPCM) SERVICES FOR
INSTALLATION OF LPG AMINE ABSORBER SYSTEM IN PFCC UNIT AT MRPL, MANGALURU**

- The entire installation shall be subjected to the following tests before energisation of installation including portable equipment:
 - a) Insulation resistance test
 - b) Polarity test of switches
 - c) Earth continuity test
 - d) Earth electrode resistance
- The test procedures and their results shall conform to relevant IS specifications. The contractor shall submit a test report for his complete installation every 2 months or after rectifying any faulty section in the specimen test report. One such test report for the complete installation shall be submitted before onset of monsoon.
- Only persons having valid wireman's license shall be employed for carrying out electrical work and repair of electrical equipment installation and maintenance at site. The job shall be supervised by a qualified licensed supervisor.
- Electricians to be provided with red helmet for easy identification.
- Electrical equipment and installations shall be installed and maintained as to prevent danger from contact with live conductors and to prevent fires originating from electrical causes like short circuits, overheating etc. Installation shall not cause any hindrance to movement of men and materials.
- Materials for all electrical equipment shall be selected with regard to working voltage, load and working environment. Such equipment shall conform to the relevant Indian Standards.
- The minimum clearance to be maintained for all overhead lines along roads and across roads shall be as per the statutory requirements.
- Grounding conductor of wiring system shall be of copper or other corrosion-resistant material. An extra grounding connection shall be made in appliances / equipment where chances of electric shock is high.
- Electric fuses and / or circuit breakers installed in equipment circuits for short circuit protection shall be of proper rating. It is also recommended that high rupturing capacity (HRC) fuses are used in all circuits. The Earth Leakage Circuit Breaker (ELCB) of 30mA max capacity shall be provided in the circuits. (ELCB) of 30mA max shall be provided on each Extension board.
- Wherever cables or wires are laid on poles, a guard wire of adequate size shall be run along the cables / wire and earthed effectively. Metallic poles as a general rule, shall be avoided and if used shall be earthed individually. Anticlimbing guards and danger notices shall be provided on poles. Each equipment shall have individual isolating switches.
- Wires and cables shall be properly supported and an approved method of fixing shall be adopted. Loose hanging of wires and cables shall be avoided. Lighting and power circuits shall be kept distinct and separate.
- Reinforcement rods or any metallic part of structure shall not be used for supporting wires and cables, fixtures, equipment, earthing etc.



**ENGINEERING, PROCUREMENT AND CONSTRUCTION MANAGEMENT (EPCM) SERVICES FOR
INSTALLATION OF LPG AMINE ABSORBER SYSTEM IN PFCC UNIT AT MRPL, MANGALURU**

- All cables and wires shall be adequately protected mechanically against damages. In case the cable is required to be laid underground, it shall be adequately protected by covering the same with bricks, Plain Cement Concrete (PCC) tile or any other approved means and provided with cable markers.
- All armored cables shall be properly terminated by using, suitable cable glands. Multistranded conductor cables shall be connected by using cable lugs/sockets. Cable lugs shall preferably be crimped. They shall be of proper size and shall correspond to the current rating and size of the cable. Twisted connections will not be allowed.
- All cable glands, armoring and sheathing of electric cables, metal circuits and their fittings, metallic fittings and other non-current carrying parts of electrical equipment and apparatus shall be effectively grounded.
- All the Distribution Boards, switches, fuse units, bus bar chambers, ducts, cubicles etc. shall have MS enclosures and shall be dust, vermin and water proof. The Distribution Boards, switches etc. shall be so fixed that they shall be easily accessible, change shall be done only after the approval of the Departmental Electrical Engineer. Distribution Boards used inside the process units shall be of Flame Proof type (Intrinsically safe type).
- Each Distribution Board shall have ELCB of 30mA max capacity.
- The contractor shall provide proper enclosures / covers of approved size and shape for protection of all the switchboards, equipment etc. against rain. Exposed live parts of all electrical circuits and equipment shall be enclosed permanently. Crane trolley wires and other conductors which cannot be completely insulated shall be placed such that they are inaccessible under normal working conditions.
- Iron soclad industrial type plug outlets are preferred for additional safety.
- Open type Distribution Boards shall be placed only in dry and ventilated rooms; they shall not be placed in the process units, vicinity of storage batteries or otherwise exposed to chemical fumes.
- Isolating switches shall be provided close to equipment for easy disconnection of electrical equipment or conductors from the source of supply when repair or maintenance work has to be done on them.
- In front of distribution boards a clear space of 90cm shall be maintained in order to have easy access during emergency.
- Adequate working space shall be provided around electrical equipment, which require adjustment or examination during operation.
- As far as possible electrical switches shall be excluded from a place where there is danger of explosion. All electrical equipment such as motors, switches and lighting fittings installed in workroom where there is possibility of explosion hazard shall be explosion proof.
- All connections to lighting fixtures, starters or other power supplies shall be provided with PVC insulated, PVC sheathed twin/three/four core wires to have better mechanical protection for preventing possible damage to equipment or injury to personnel. Taped joints shall not be allowed. Electric starter of motors, switches shall not be mounted on wooden boards. Only sheet mounting or iron framework shall be used.



**ENGINEERING, PROCUREMENT AND CONSTRUCTION MANAGEMENT (EPCM) SERVICES FOR
INSTALLATION OF LPG AMINE ABSORBER SYSTEM IN PFCC UNIT AT MRPL, MANGALURU**

- All the lighting fixtures and lamp holders shall be of good quality and in good condition. Badly repaired or broken holders, etc. shall not be used.
- Only PVC insulated and PVC sheathed wires or armoured PVC insulated and sheathed cables shall be used for external power supply connections of temporary nature. Weatherproof rubber wires shall not be used for any temporary power supply connections.
- Taped joints in the wires shall not be used. In case joints are required on electrical cables then only heat shrinkable PVC sleeves will be allowed.
- The bulbs/lamps used for illumination and testing purpose shall have cover or guard to protect them from accidental breakages. Only 24V supply system shall be used for hand lamps etc. while working inside metallic tanks or conducting vessels (Confined spaces).
- After installation of new electric system and or other extensive extensions to existing installations, thorough inspection shall be made by Contractor's Electrical Engineer before the new system or new extension is put in use.
- All persons who work with electrical installation/equipment shall be aware of the electrical hazards, use of protective devices and safe operational procedures. They shall be given training in fire fighting, first aid and artificial resuscitation techniques, location of isolation switches, etc.
- The supervisor shall instruct the workers in the proper procedure, specify and enforce the use of necessary protective equipment such as adequately insulated pliers, screw drivers, fuse pullers, testing lamps and similar hand tools. Only wooden ladders shall be used to reach the heights in electrical work.
- No material or earthwork shall be allowed to be dumped below or in the vicinity of the bare overhead line conductors.
- Separate work permits shall be issued for individual group leaders working on the same system which shall be returned after the completion of the work to the Engineer-In-Charge.
- Before any maintenance work is commenced on electrical installations/equipment, the circuits shall be de-energised and ascertained to be dead by positive test with an approved voltage testing device. Switches shall be tagged or the fuse holders withdrawn before starting the work. Adequate precautions shall be taken in two important aspects viz. LOTO system to be followed.
- That there shall be no danger from any adjacent live parts and
- That there shall be no chances of re-energisation of the equipments on which the persons are working. (Tag out and lock out LOTO system to be strictly followed).
- While working on or near a circuit, whenever possible the use of one hand may be practiced even though the circuit is supposed to be dead. The other hand may preferably be kept in pocket.
- When it is necessary to touch electrical equipment (for example when checking for overload of motors) back of the hand may be used. Thus, if accidental shock were to cause muscular contractions, one would not "freeze" to the conductor.
- Operation of electrical equipment shall be avoided when standing on wet floor or when hands are wet. Rubber mats should be placed in front of Panels / Distribution Boards as per Indian Standards.



**ENGINEERING, PROCUREMENT AND CONSTRUCTION MANAGEMENT (EPCM) SERVICES FOR
INSTALLATION OF LPG AMINE ABSORBER SYSTEM IN PFCC UNIT AT MRPL, MANGALURU**

- Before blown fuses are replaced, the circuit shall be locked out and an investigation shall be made for the cause of the short circuit or overload.
- When two persons are working within reach of each other, they shall never work on different phases of the supply.
- When structural repairs, modification or painting work are to be undertaken, appropriate measures shall be taken for the protection of persons whose work may bring them into the proximity of live equipment / circuit.
- It shall be ensured that the insulation and wire size of extension cords is adequate for the voltage and current to be carried.
- While tapping electricity from the socket, plug top must be used. It shall be ensured that no extension boards are over loaded while tapping. Only standard three pin plugs (Naked Wire is prohibited) shall be used for tapping electricity. Broken sockets/plugs shall be replaced immediately with good ones. Only joint free cables shall be used for connecting equipment/Use of apparatus.
- Floors shall be kept free from trailing electrical cables to avoid tripping hazard.
- Power supply to all the machines and lighting fixture shall be switched off when not in use.
- Temporary electrical connections shall be removed as soon as the stipulated work is over. After completion of the works, the contractor shall dismantle the distribution boards and the other facilities he may have erected.
- Unauthorised tapping of power by others from distribution boards under the control of the contractor shall be prohibited at all circumstances.
- No flammable materials shall be stored in any working area near the switchboards.
- Safety work permits shall be used for switching off the main feeder and equipment by the contractor.
- "MEN ON LINE" "DO NOT SWITCH ON" "DANGER" or "CAUTION" boards as applicable shall be used during maintenance works on the electrical equipment.

30. PORTABLE ELECTRICAL EQUIPMENT:

- Portable electrical tools must be examined, maintained and tested daily, fortnightly and quarterly so that the equipment and its leads are in good order. Register shall be maintained for inspection recording the testing dates and results of the equipments. Inspection checklists to be formed to that effect. The recertification of lifting tools, tackles, equipments etc. must be carried out well before the expiry of its validity period.
- All portable appliances shall be provided with three core cable and three pin plugs. The third pin of the plug shall invariably be earthed. It shall be ensured that the metal part of the equipment shall be effectively earthed.



**ENGINEERING, PROCUREMENT AND CONSTRUCTION MANAGEMENT (EPCM) SERVICES FOR
INSTALLATION OF LPG AMINE ABSORBER SYSTEM IN PFCC UNIT AT MRPL, MANGALURU**

- All connections to portable equipment or machines from the panel/distribution board/extension board shall be taken using 3 core double insulated PVC flexible copper wire in one length. No joints shall be allowed in this flexible wire. In case length of wire is not sufficient for a particular location then the supply can be tapped by providing another extension board comprising of switch, socket and ELCB of 30mA max.
- Flexible cables for portable lamps, tools and apparatus shall be regularly examined, tested periodically and maintained to ensure safety.
- For excavations, one time clearance from electrical is required for a particular area.
- Contractor shall get their welding machine / Stress Relieving (SR) electrical equipment / all portable machine certified by MRPL / MRPL authorised contractor and seal will be fixed on machine to that effect. Certificate from third party mentioning the checks carried out, repairs carried out and safe to use to be submitted to Engineer Incharge.
Revalidation to be done once in 4 months. In case contractor does not comply, it will be done by MRPL and four times the cost of repair will be back charged to contractor.
- In case of welding, separate return cable from job piece to welding machine to be connected. Wires not to be used. PVC insulated cables only to be used.
- All lighting circuits/temporary connections for portable machine should have ELCB's of 30mA capacity max.
- All ELCBs to be tested once in 15 days using ELCB testers (and not by the lamp with open wires) and record maintained. Also separate register for ELCB trips (TRIP REGISTER) shall be maintained. It shall be daily signed by the site Incharge of the contractor.
- Earthing of Neutral, which will act as return path, is not allowed.
- Electricians should have wireman license.
- During monsoons, monsoon protection for electrical equipment to be done.
- All feeders in contractor distribution panel to be clearly lettered with load details for isolation in case of emergency.
- Insulated tools like screwdriver, cutting plier, tester to be used.
- Each contractor should have one set of multimeter, ELCB tester and tong tester.
- First aid kit to be available.
- The contractor must have a team of Experienced Electricians (having minimum of 10 yrs. experience in carrying out safety inspection and testing of Electrical Equipments, tools, portable electrical machines and appliances etc.) to conduct periodical (Daily, fortnightly, monthly and quarterly) inspection and testing of Electrical Equipments, tools and portable electrical machines, tools and appliances and to maintain its records.
- All power cable ends should have industrial plug on one side and other end directly into the machine. (No naked end pinning into will be permitted).
- For any job within MCC / SRR a work permit will be issued by MRPL operation. Job should not be started without these permits.



ENGINEERING, PROCUREMENT AND CONSTRUCTION MANAGEMENT (EPCM) SERVICES FOR INSTALLATION OF LPG AMINE ABSORBER SYSTEM IN PFCC UNIT AT MRPL, MANGALURU

31. ROLE OF CONTRACTOR INCASE OF EMERGENCY AND SIREN:

- Contractor shall instruct his workers to follow instructions strictly in case of fire siren / emergency or if advised or felt necessary by Engg. In-charge. If evacuation is ordered they must leave the work site and proceed towards the nearest designated assembly point. The contractor and its employees MUST follow specific instructions (Roles and Responsibilities incase of fire / onsite emergency) that will be given during training from time to time. All contractor employees MUST undergo such training, before their deployment at the work site. Contractor shall arrange & conduct such trainings for his employees and also employees of sub-contractors.
- Contractor shall instruct his workers to stop all jobs immediately incase release of liquid/gas/toxic/hazardous chemicals etc, and inform the concerned MRPL personnel available at site.

32. TRAINING:

- The contractor to conduct Induction training of all employees and record maintained.
- The contractor will have to depute all his employees (including Engineers, supervisors and workmen), before they commence work for the first time at MRPL site and subsequently once in a year, to undergo Safety training. They will get photo gate passes only after the completion of the training. Contractors MUST have and get conversant with Material Safety Data Sheets of all the Chemicals in MRPL. It is a MUST for them to carry the photo passes with them and produce it when demanded at site.
- Tool box talks to be conducted every day before starting of each shift and before commencing of work after lunch break by the concerned Engineer.

33. LIST OF PERSONAL PROTECTIVE EQUIPMENTS:

The contractor must poses the following minimum safety Items cum Personal Protective Equipments. All Personal Protective Equipments used at site to be of approved make.

34. MANDATORY FOR THE CONTRACTOR EMPLOYEES WHILE WORKING INSIDE REFINERY:

* Deployment of adequate nos. of safety officers as per table above and making available the mandatory items as per the minimum list below is a MUST as a part of mobilization activity.

1. Safety Helmet.
2. Safety shoes (Conforming to IS standards with ankle protection, steel toe and anti-skid / acid, alkali and water proof soles).
3. Hand gloves (Leather impregnated cotton hand gloves).
4. Spectacle type goggles with toughened glass lenses, plain face shields with and without chin guards.

The contractor must use the "ISI" marked Personal Protective Equipments specific to the job. It is mandatory to have minimum backup stock of all the PPEs in addition to what is already in use at site.



35. SPECIFICATIONS FOR SAFETY HELMETS-HDPE:

1. Helmet Safety Industrial HDPE white colour.
2. Contractor's Logo at front side.
3. Conforming to IS 2925, ISI marked & DGMS approved.
4. Nape strap type adj. type 6 point adj. head band & sweat band with 3/4"CottonChinstrap.

* Green helmets for Safety Personnel and Red helmets for electricians to be provided and used by them.

36. SPECIFICATION FOR FULL BODY SAFETY HARNESS) SAFETY BELT

Full Body Safety Harness (Safety belts) must be double lanyard type with scaffolding hook having self closing latch (spring type).

Different type of hooks to be available based on the nature of job / type of support. Safety belts should be ISI marked and should conform to IS 3521 and DGMS approved and stamped.

Safety belts, safety straps, lifelines, permanent anchors and connections should both separately and when assembled:

- a) Be capable of supporting safely a suspended load of at least 450 kg (1,000 lb) ; and
- b) Have a breaking strength of at least 1,150 kg (2,500 lb).

If hooks are used for attaching safety belts to fixed anchors, they should be self closing safety hooks of various types and sizes.

When a lifeline or safety strap is liable to be served, cut, abraded or burned, it should consist of a wire rope or a wire-cored fiber rope.

Safety straps should be so fastened to safety belts that they cannot pass through the belt fittings if either end comes loose from its anchorage.

Metal thimbles should be used for connecting ropes or straps to eyes, rings and snaps. Safety belts, safety straps and lifelines should be so fitted as to limit the free fall of the wearer to 1m (3ft 3in).

37. SPECIFICATION FOR FALL ARRESSTOR DEVICE:

Fall arresstor device with self-retracting cable integrating locking mechanism combined with an energy deception element fully automatic having cables of various lengths, ISI and DGMS and or any international approval. Only Poly Amide rope shall be used.

38. SPECIFICATION FOR DUST MASK:

Dust Mask made of superior quality non-aging chemical-resistant rubber half face piece with reflex sealing flaps for protection against nuisance dust, (<0.5 micron) toxic dusts, gases and vapours with replaceable filters.



39. SPECIFICATION FOR REPLACEABLE FILTERS

For protection against nuisance dust, toxic dusts, gases and vapours upto a concentration of 500 ppm. To be fitted on aforesaid Dust Mask

40. SPECIFICATION FOR SAFETY SHOES

1. Safety Shoes, Jodhpury style- as per is 11226- 1985 with guarantee for 1& 1/2 years (all weather).
2. Acid/ alkali/ waterproof heat resistant, antiskid green PVC Nitrile sole.
3. Steel toe cap as per relevant "IS".
4. Upper plain leather, high ankle, with metallic 4 eyelets.
5. ISI marked.
6. The supplier should give guarantee of use of safety shoes during rainy season.

41. STANDARD SPECIFICATION FOR PVC HAND GLOVES

Hand contoured for greater comfort & feature an embossed nonslip grip for handling wet or greasy objects cotton flock lining absorbs perspiration maximises easy on/off black with straight cuff each pair pack.

42. SPECIFICATION FOR ELECTRICAL PPE (SHOCK PROOF)

Hand gloves used for live electrical works shall be of proper electrical rating.

Electrical (shock proof) Safety Shoes (Jodhpury type) with acid/ alkali/ water proof, heat resistant, antiskid sole with guarantee for 1&1/2 years (all weather).

1. Upper plain leather.
2. ISI marked & latest certificate of testing from any of the govt. recognised institution for electrical resistance.

GUMBOOTS with steel toe should be used by personnel during rainy season.

The aforesaid guidelines are the minimum safety requirements and the contractor should exceed them so as to achieve "ZERO ACCIDENT" which is our MOTO.

43. TYPE SAFETY VIOLATIONS AND PENALTY SYSTEM:

All the contractors working for MRPL shall strictly follow the safety norms as per the rules and regulations of MRPL. Contractors who violate safety norms while executing the jobs will be penalized financially.

The details of penalty amount against each safety violations is enclosed as Annexure-B.



**ENGINEERING, PROCUREMENT AND CONSTRUCTION MANAGEMENT (EPCM) SERVICES FOR
INSTALLATION OF LPG AMINE ABSORBER SYSTEM IN PFCC UNIT AT MRPL, MANGALURU**

Annexure B

SL No	Type of Safety Violations	Amended/New penalty
1	No Lost Time Incident (NLTi) – Reporting back to duty within 48 hrs	First occasion Rs 2,500/- Second occasion Rs 5,000/- Third occasion Rs 10,000/- In addition to other expenses borne by contractor towards treatment. Existing Policy: none
2	Reportable Lost Time Incident (RLTI) – No reporting to duty within 48 hrs	First occasion Rs 10,000/- Second occasion Rs 25,000/- Third occasion Rs 50,000/- In Addition to other expenses borne by contractor towards treatment. Existing Policy: none
3	Disability	Rs 1,50,000/- per person Existing Policy: none
4	Fatal	Rs 5,00,000/- per person Existing Policy: none
5	Vehicle Accident – Vehicle damaging Property or Vehicle to Vehicle Accident.	Rs 25,000/- and Repairs/damage/restoration Existing Policy: none
6	For not using Personal Protective Equipment like (Safety Helmet, Safety Goggles, Safety Shoes, Hand gloves, Boiler suit, etc)	Rs 500/- Per day/ per item/ per person for first violation. Rs 1,000/- for second onwards.
7.	Working without permit/ Clearance (Cold Work)	Rs 5,000/- per occasion After 3 violations, holiday listing for 6 months.
8	Hot work without proper permit/ Clearance	Rs 10,000/- per occasion. After 3 violations, holiday listing for 6 months
9	Non-use of safe electricity at work site (non installation of ELCB, using poor joints of cables, using naked wire without top plug into socket, laying wire/ cables on the roads, etc.	Rs 3,000/- per item
10	Working at heights without safety belt (Full Body Safety Harness), using non-standard scaffolding and not arranging fall protection arrangement as required	First occasion Rs 2,500/- Second occasion Rs 5,000/- Third occasion Rs 10,000/- After three occasions, holiday listing for 6 months
11	Unsafe handling of compressed gas cylinders (No trolley, jubilee clips, double gauge regulator, Improper storage/ handling).	Rs 500/- per occasion
12	Non fencing/ barricading of excavated areas	Rs 1,000/- per occasion
13	Use of domestic/ commercial LPG cylinder for cutting purpose	Rs 1,000/- per occasion.
14	Non-display of name board, permit, etc at site	Rs 500/- per occasion
15	Not providing shoring/ strutting/ proper slope and not keeping the excavated earth at least 1.5m away from the excavated area	Rs. 2,000/- per occasion



**ENGINEERING, PROCUREMENT AND CONSTRUCTION MANAGEMENT (EPCM) SERVICES FOR
INSTALLATION OF LPG AMINE ABSORBER SYSTEM IN PFCC UNIT AT MRPL, MANGALURU**

16	Wrong parking of vehicles or parking the vehicles at non-designated places inside refinery	Rs 1,000/- per occasion
17	Absence of contractor representative in refinery safety meetings whenever called	Rs 3,000/- per meeting
18	Non-deployment of safety supervisor/ supervisor responsible for safety at work site required as per Special Safety Conditions	Rs 3,000/- per day
19	Failure to maintain safety register and records by contract Safety Supervisor or the Supervisor responsible for safety	Rs 1,000/- per day
20	Failure to have daily safety site inspection/ audits, monthly safety meetings and maintain records (by contractors themselves)	Rs. 1,000/- for each occasion
21	Failure to submit monthly safety report by the 5th of the next month to the Engineer-In-Charge	Rs. 1,000/- per occasion
22	Poor Housekeeping	Rs 1,000/- per site/ per day
23	Failure to follow injury reporting system	Rs 10,000/- per occasion
24	Violation of safety condition as per Job Safety Analysis (JSA)	Rs 10,000/- per occasion
25	Over-Speeding of vehicle i.e speed > 16 KMPH while driving inside refinery	The driver will be removed and gate pass will be withdrawn. Contract will be cancelled upon repeated three violations
26	Overtaking of vehicles while driving inside refinery	The driver will be removed and gate pass will be withdrawn Contract will be cancelled upon repeated three violations
27	Driving of vehicle without valid license	First occasion Rs 1,000/- Second occasion Rs 2,000/- The driver will be removed and gate pass will be withdrawn. Contract will be cancelled upon repeated three violations.
28	Driving vehicle without PESO approved or PESO approved but damaged spark arrester	The driver will be removed and gate pass will be withdrawn. Contract will be cancelled upon repeated three violations.
29	Driving vehicle on "NO ENTRY ROADS"	The driver will be removed and gate pass will be withdrawn. Contract will be cancelled upon repeated three violations.
30	Denying to produce the photo Gate Pass on demand	Rs 500/- per person per occasion
31	Contract worker found drunk/intoxicated state inside the refinery	Rs 15,000/- per person per occasion



ENGINEERING, PROCUREMENT AND CONSTRUCTION MANAGEMENT (EPCM) SERVICES FOR INSTALLATION OF LPG AMINE ABSORBER SYSTEM IN PFCC UNIT AT MRPL, MANGALURU

Standard Operating Procedure for Social Distancing at MRPL

Sl. No.	Procedure	Action plan
1	All areas in the premises including the following shall be disinfected completely using user friendly disinfectant mediums a. Entrance Gate of building, office etc. b. Canteens and pantries c. Meeting room, Conference halls / open areas available/ veranda/ entrance gate of site, bunkers, porta cabins, building etc. d. Equipment and lifts. e. Washroom, toilet, sink, water points etc. f. Walls/ all other surfaces	Disinfection of all the areas and Refinery Township on regular intervals is being strictly followed.
2.	For workers coming from outside, special transportation facility will be arranged without any dependency on the public transport system. These vehicles should be allowed to work only with 30-40% passenger capacity.	Being followed.
3	All vehicles and machinery entering the premise should be disinfected by spray mandatorily	All vehicles hired by MRPL are being disinfected at regular intervals.
4	Mandatory thermal scanning of everyone entering and exiting the work place to be done	Body temp monitoring all who are entering and exiting through all the gates in all the shifts being done.
5	Medical insurance for the workers to be made mandatory.	Medical insurance is available for MRPL employees. Term insurance is available for contract workers apart from ESI.
6	Provision for hand wash & sanitizer preferably with touch free mechanism will be made at all entry and exit points and common areas. Sufficient quantities of all the items should be available	Hand wash and sanitisers are kept in all the places. Sufficient stock is available.
7	Work places shall have a gap of one hour between shifts and will stagger the lunch breaks of staff, to ensure social distancing	Shift/ General shift timings are staggered to ensure social distancing.
8	Large gatherings or meetings of 10 or more people to be discouraged. Seating at least 6 feet away from others on job sites and in gatherings, meetings and training sessions.	Awareness through circular and office orders. Necessary care is taken in seating to maintain distance.
9	Not more than 2/4 persons (depending on size) will be allowed to travel in lifts or hoists.	Awareness through circular and intranet.
10	Use of staircase for climbing should be encouraged	Awareness through circular and intranet
11	There should be strict ban of gutka, tobacco etc, and spitting should be strictly prohibited.	Awareness through circular and intranet
12	There should be total ban on non-essential visitors at sites.	Awareness through circular and intranet
13	Hospitals/clinics in the nearby areas, which are authorised to treat COVID-19 patients, should be identified and list should be available at work place all the times.	List prepared and available in Hospital.



**MINIMUM MANPOWER REQUIREMENT
OF
KEY CONSULTANT PERSONNEL**

[ANNEXURE – III TO SPECIAL CONDITIONS OF CONTRACT]

1. MINIMUM MANPOWER REQUIREMENT - MOBILIZATION OF KEY
CONSULTANT PERSONNEL



MINIMUM MANPOWER FOR SITE DEPLOYMENT

Sl no	CATEGORY	Minimum Manpower required in Numbers
1	Resident Construction Manager/ Resident Engineer/Site-In-Charge	01
2	Safety Officer / Supervisor	01

Notes:

1. Above key minimum basic manpower is required to be deployed by the consultant at site during the site construction activities.
2. Further Consultant is required to augment the above list with additional numbers/ categories of experienced personnel as required during project execution period for Process / Civil / Electrical / Mechanical / Instrumentation / QA / QC/ Planning /stores /safety /billing /HR/ Finance, etc activities at site and as directed by Engineer-In-charge to complete the work/services within the completion time schedule and lumpsum quoted price.
3. The Key Construction Personnel identified above shall be well qualified & having adequate relevant experience as per service requirement. Other manpower deployed by Consultant shall also be qualified and experienced with their assigned work.
4. CVs of key construction personnel proposed to be deployed shall be submitted to Owner/ Engineer-in-Charge prior to their mobilization at site. The mobilization of key personnel shall be done at site subject to prior approval of their CVs by Owner/Engineer-in-Charge.



EXHIBIT 3

COMPLETION SCHEDULE

Consultant has to strictly adhere to the timelines mentioned below; In case of non-adherence to the timelines PRS / penalties as mentioned in the section of PRS / penalties will be applicable

TABLE A		
Sl. No.	DESCRIPTION OF SERVICES	TIME OF COMPLETION
1	EPCM Services for installation of LPG Amine Absorber system in PFCC Unit at MRPL, Mangaluru, as per Tender No. 3200000464	Mechanical Completion Within 24 (Twenty four) Months from issue of LOA

Break Up of Consultant's Deliverables Timeline (TABLE B)

TABLE B		
Sl. No.	SEQUENCE OF ACTIVITIES	TIME LINE
1	Submission of Total Landed cost estimate for the project (+/-10%) including FEED	Within 3 months from date of issue of LOA
2	Floating of Procurement RFQs and Works tenders for the Project.	Within 6 Months from date of issue of LOA
3	Tendering cycle time duration from RFQ / tender floating to recommendation for award / ordering	Within 3 Months
4	Mechanical Completion of the Project	24 months from the date of issue of LOA
5	Commissioning of the Project	Within 2 months from Mechanical Completion
6	PGTR of the Project	Within 3 months from Commissioning
7	Final Closure of all Contracts	Within 9 months from Mechanical Completion

CONSULTANT has to strictly adhere to the timelines mentioned above.

EXHIBIT 4

PRICE REDUCTION SCHEDULE AND PENALTIES

1.0 Price Reduction Schedule (PRS)

- a. This is a time bound job and in the event of any delay in completion of work of achieving Mechanical completion due to reasons attributable to Consultant, the Consultant will be liable for Price Reduction Schedule at the rate of 0.5 % per week of such delays subject to a maximum amount of 5% of the executed portion of total contract value.
- b. MRPL may without prejudice to any methods of recovery, deduct the amount of such PRS from any money due or which may at any time become due to Consultant from its obligations and liabilities under the contract. Both Consultant and MRPL agree that the above percentage of price reduction are genuine pre-estimates of the loss / damage which MRPL would have suffered on account of delay / breach on the part of Consultant and the said amount will be payable on demand without there being any proof of the actual loss / or damage caused by such delay / breach. A decision of MRPL in the matter of applicability of price reduction shall be final and binding.

2.0 Penalties

If there is any delay by Consultant for completion of final closure of all contracts / orders of the PROJECT within the time schedule as specified in Exhibit-3, due to reasons attributable to Consultant, the Consultant will be liable for penalty at the rate of 0.5 % per week of such delays subject to a maximum amount of 2% of the total contract value.

Limitation of Liability: The overall limit of Consultant's liability under this Contract for all guarantees, warranties, liquidated damages, PRS, Penalties of whatsoever nature, whether expressed or implied shall be limited to Twenty percent (20%) of the executed portion of the total contract value.



EXHIBIT 5

MRPL'S OBLIGATIONS

1. Taking Mega risk erection policy which covers the project assets within project site (Insurance other than the Mega risk erection policy is to be covered by the bidder).
2. All permits as required for the project.
3. Environmental studies and clearances.
4. Right of way required for the project.
5. Liaison with statutory bodies and local authorities for obtaining statutory clearance and work permits etc. and payment of statutory fees (other than, which are in the scope of contractors).
6. Contractor / Supplier / Vendor payments upon certification from Consultant
7. Space for keeping portable office container near site office for Consultant site office.
8. Power free-of-cost for office purposes, at one location.
9. Security passes / entry permits on submission of required documents
10. Consultant to publish all press advertisement / notices etc. in mutually agreed newspapers if applicable as per C&P Procedure. Costs for all press advertisements / notices shall be reimbursed to Consultant on production of actual bills / receipts.
11. Vendor payment, retiring of bank documents, management of bank guarantees received in favour of MRPL and opening and maintaining of L/C against foreign supplies.
12. Custom clearance for items / materials directly ordered by MRPL. Consultant shall coordinate for the same.
13. Final payment to vendors based on MRR issued and final certification of bills / invoices by Consultant
14. Warehouse stores shall be provided free of cost by MRPL along with required rack for storage
15. Watch and Ward including site security and site access for the project facilities and warehouse.



EXHIBIT 6

EXCLUSIONS FROM CONSULTANT'S SCOPE

The following are specifically excluded from Consultant's scope of work under this contract. All activities not specifically mentioned here are deemed to be in scope of Consultant.

1. Appointment of back up Consultant, if any (not envisaged by Consultant)
2. Approvals / clearance, statutory approvals and clearances and obtaining any Right of Ways required for the Project shall be in MRPLs scope. However, Consultant shall advise MRPL on the requirement and provide technical assistance for the same including visits to the offices as required. The site contractor's scope shall include liaison with statutory authorities (like PESO / IBR / Factories / CEA etc.) as necessary. Industrial relations and Liaison with local labour authorities, municipal authorities, excise authorities, EPF authorities, local Government and such other statutory bodies / Law enforcing agencies shall be the added to the site contractors' scope. However, Consultant shall inspect, audit and certify the compliances of all labour laws by the site contractors including but not limited to payment of wages, PF, ESI and other labour related benefits.
3. Leasing of land if required for warehouse / fabrication facilities shall be directly done by MRPL. However, identification of land shall be jointly done by MRPL and Consultant
4. Subject always to the Conditions of Contract, any legal suit or arbitration proceeding shall be defended by MRPL and Consultant shall provide assistance with respect to Consultant deliverables up to two years after Mechanical Completion. Beyond that period on mutually agreed terms and conditions.
5. Product evacuation systems beyond the agreed scope.
6. All types of insurance except insurance for Consultant personnel
7. Settlement of Insurance claims. However, Consultant shall initiate the claim within stipulated time and carry out other required actions and assist Owner for the claiming of insurance.
8. All audit / vigilance queries from any government bodies. CONSULTANT shall provide clarification and technical assistance. However, Consultant confirms that all activities shall be carried out confirming to CVC and other guidelines published from time to time. Lapses on this account shall be held on account of Consultant.
9. Retiring of documents of vendors including bank guarantees.
10. Payment to site contractors. However, Consultant shall verify that payments of site sub-contractors and labour have been carried out by contractors.
11. Watch and Ward including site security and site access for the project facilities and warehouse.
12. Foreign travel / visit, which shall be payable additionally by MRPL based on per diem rates and all travel and related expenses like accommodation, living allowance, visa charges etc. as per MRPL's norms in vogue shall be reimbursed.



EXHIBIT – 7

WARRANTIES AND GUARANTEES

1.0 General Warranties:

- 1.1 Consultant guarantees that the basic design, detailed design and engineering performed by Consultant as specified and described in this Contract and the technical documentation to be developed and shall be in accordance with sound and established engineering practice, using engineering codes, standards and Indian Regulations where applicable, free from defects and suitable for respective uses intended
- 1.2 Consultant warrants that:
 - 1.2.1 Personnel: All professional personnel of Consultant shall have proper qualifications for the SERVICES assigned to them hereunder and shall deploy the required number of personnel.
 - 1.2.2 Standard of Care and SERVICES: Consultant shall perform their obligations under this Contract in conformity with the highest international standards of care employed by leading engineering firms in the petroleum refinery industry and all services shall be Excellent.
 - 1.2.3 Management, Design and Development: The management, design and development of the services shall conform to this Contract and shall be free of defects and deficiencies. The management, design and development shall be such that the services shall comply with the terms of this Contract and shall meet all design, safety and performance and other criteria as specified herein.
 - 1.2.4 ENGINEERING: In the event of faulty or defective engineering undertaken or performed by Consultant within the scope of services described in Exhibit 2, Consultant shall promptly and at its own cost and initiative carry out and undertake corrective design, drawings and engineering as may be necessary to rectify the fault or defect without any additional cost to MRPL. However, no such liability shall be after 18 months from date of mechanical completion or 12 months from the date of commissioning, whichever is earlier.
 - 1.2.5 SERVICES: The services shall be fit for the purposes and uses intended and capable of use in the manner contemplated in the Contract.
 - 1.2.6 Other Services: All services performed by Consultant not otherwise mentioned in this Para 1.1, including, without limitation, inspections performed by Consultant or its Subcontractors under this Contract, shall be adequate and sufficient for the purposes intended, in conformity with the terms of this Contract and free of defects and deficiencies. Consultant's obligation to manage, design and develop the services correctly, and the General Warranties set forth above, shall not be reduced or affected by any inspection, test, acceptance or payment, MRPL's approval of any designs, drawings or specifications, or by the issue of the Certificate of Acceptance of the services or any re-performance or replacement of any part of the services.
- 1.3 Remediation
 - 1.3.1 Notice: At any time MRPL may by notice in writing to Consultant, require Consultant to remedy any defect in the services within the scope of Consultant by re-performance not later than 18 months from date of Mechanical Completion or 12 months from the date of commissioning, whichever is earlier.



- 1.3.2 **Obligation to Remedy Breach:** Consultant shall be obligated to effect, at its own expense, in the shortest practicable time, such re-performance and replacement as are necessary to remedy such defect.
- 1.3.3 **Program for re-performance:** As soon as practicable, and in any event within 5 working days after the receipt by Consultant of MRPL's notice, Consultant will submit for MRPL's approval a plan for effecting the re-performance required to remedy such breach. If required by MRPL, Consultant shall attend at the site or at place(s) specified by the MRPL to inspect the defective services and where appropriate arrange to carry out repairs to the defective work.
- 1.3.4 **MRPL's Recourse:** If Consultant does not begin its plan for re-performance within the time mutually agreed, or if Consultant and MRPL fail to reach agreement on such a program within 5 working days of the receipt by MRPL of Consultant's plan submitted pursuant to Para 1.2.3, MRPL, after advising Consultant in writing, shall be entitled at this option to perform or have third parties perform such work as is necessary to remedy or cause to be remedied. The payment to third parties will be recovered from Consultant.
- 1.4 **Completion Warranty**
- 1.4.1 Completion Warranty: Without limiting the effect of the General Warranties or any other provision of this Contract, Consultant warrants that commissioning and contract closure shall be as specified in Completion Schedule (Exhibit 3) and as defined elsewhere.
- 1.4.2 Without Limiting effect of the General Warranties or any other provision of this Contract, Consultant warrants and acknowledges the time for commissioning and contract closure as specified under the Completion Schedule (Exhibit 3). The time for performance / completion of EPC phase will be duly covered along with applicable liability Clauses in the Contracts and Consultant undertakes to maintain the follow-up and generation of documentation required to monitor progress and assist MRPL in claiming and recovering the full liability and damages available to the MRPL attendant upon any delay of performance under Contract.
- 1.4.3 **Effect of Breach:** If Consultant breaches the completion warranty set forth in Exhibit-3 including Para 1.4.1 above and the delay is solely attributable to Consultant, Consultant shall be liable for levy of PRS and Penalties as per Exhibit-4.

2.0 GENERAL GUARANTEES:

- 2.1 In the event of faulty or defective Design, Hazop Study, Engineering Design Basis and / or review of detailed Engineering of the Plant / Unit and / or faulty approval of design(s), drawing(s) and specifications, including error or omission in the technical services or studies done, undertaken or performed by Consultant within the scope of Work described in Exhibit-2, Consultant shall promptly and at its own cost and initiative carry out and undertake corrective studies, design(s), drawing(s) and engineering as may be necessary to rectify the fault or defect without any additional cost to the MRPL. However, no such liability shall lie after expiry of Defect Liability Period, if the Performance Guarantees have been met by LSTK contractor.
- 2.2 For the benefit of MRPL, Consultant shall include in Purchase Orders and Work Contracts a requirement for guarantees from equipment, materials vendors and contractors against defects in materials and workmanship and shall assist MRPL in the enforcement of such guarantees. However, Consultant shall not be required to enter into any litigation with vendors / contractors on behalf of MRPL. Consultant shall ensure that the purchase specifications for all equipment and material adequately specify requirements of quality, process operating conditions / working condition at site applicable codes



ENGINEERING, PROCUREMENT AND CONSTRUCTION MANAGEMENT (EPCM) SERVICES FOR INSTALLATION OF LPG AMINE ABSORBER SYSTEM IN PFCC UNIT AT MRPL, MANGALURU

and standards and special condition, if any. Consultant shall specify or undertake such tests and inspections as are normally required to ensure that all equipment and material to be procured, conform to the specifications and relevant codes and standards. Consultant shall ensure that the construction specifications for all works adequately specify the requirement of quality, working conditions at site, applicable codes and standards and special conditions, if any.

- 2.3 **Defect liability period** shall be 18 (Eighteen) Months from mechanical completion or 12 (Twelve) Months from the date of commissioning, whichever is earlier.



EXHIBIT 8
GENERAL CONDITIONS OF CONTRACT (GCC)

INDEX

CLAUSE. No.	DESCRIPTION
	SECTION - I
1.0	DEFINITIONS
	SECTION - II
2.0	LOCATION AND ACCESS OF SITE
3.0	SCOPE OF WORK
4.0	CONSTRUCTION POWER & WATER
5.0	ACCOMODATION
6.0	TRANSPORTATION
7.0	CONSTRUCTION EQUIPMENT
8.0	PUTTING UP OF BUILDINGS ON PROJECT SITE
	SECTION - III
9.0	GENERAL GUIDELINES
10.0	CORRECTNESS OF DOCUMENT
11.0	EARNEST MONEY DEPOSIT
12.0	BID VALIDITY / BID OPENING
13.0	RIGHT OF OWNER TO ACCEPT OR REJECT TENDER
14.0	TIME SCHEDULE/MOBILISATION/COMPLETION PERIOD
15.0	SITE ORGANISATION
16.0	UNDERGROUND AND OVERHEAD STRUCTURES
17.0	CO-ORDINATION WITH OTHER AGENCIES
18.0	NOTE TO SCHEDULE OF RATES
19.0	ACCEPTANCE OF TENDER
20.0	ISSUE OF WORK ORDER / LOI
	SECTION - IV
21.0	INTERPRETATION OF CONTRACT DOCUMENTS
22.0	SECURITY DEPOSIT
23.0	RECOVERY OF SUMS DUE
24.0	FORCE MAJEURE CLAUSE
25.0	PRICE REDUCTION SCEHDULE (PRS) FOR DELAYS EXECUTION OF CONTRACT
26.0	PENALTY CLAUSES
27.0	SUB-LEASING / OPERATION OF CONTRACT
28.0	SUSPENSION OF WORKS
29.0	CANCELLATION
30.0	TERMINATION
31.0	INSPECTION / OPERATION CONTRACT
32.0	MAKE OF EQUIPMENTS/COMPONENTS
33.0	QUALITY ASSURANCE SYSTEM
34.0	TEST AND INSPECTION OF WORKS
35.0	DEFECT LIABILITY
36.0	LIMITATION OF LIABILITY
37.0	RISK PURCHASE CLAUSE
38.0	COPY RIGHT / TRADE MARK OF MRPL RELATED DISCIPLINE
39.0	ROYALTY
40.0	BUSINESS SECRET/MARKETING DISCIPLINE



**ENGINEERING, PROCUREMENT AND CONSTRUCTION MANAGEMENT (EPCM) SERVICES FOR
INSTALLATION OF LPG AMINE ABSORBER SYSTEM IN PFCC UNIT AT MRPL, MANGALURU**

41.0	SEVERABILITY
	SECTION - V
42.0	PAYMENT TERMS
43.0	ADVANCE PAYMENT / MOBILISATION ADVANCE
	SECTION - VI
44.0	ARBITRATION & CONCILIATION
45.0	JURISDICTION
	SECTION - VII
46.0	TAXES AND DUTIES
47.0	CHANGE IN LAW
	SECTION - VIII
48.0	MANPOWER EMPLOYED BY TENDERER
49.0	MEDICAL
50.0	LABOUR LAWS
51.0	LABOUR RELATIONS
52.0	CONTRACTOR'S LABOURERS TO LEAVE SITE ON COMPLETION OF THE WORK
53.0	TEMPORARY WORKS
54.0	PROVIDENT FUND
55.0	OBSERVATION OF FORMALITIES RELATING TO PF, ESI REGISTRATIONS
56.0	INSURANCE
57.0	CONSULATNT FURNISHED INSURANCE
58.0	VERIFICATION OF CHARACTER AND ANTECEDANTS OF CONTRACTUAL MANPOWER
59.0	BROAD GUIDELINES FOR EFFECTIVE IMPLEMENTATION OF CONTRACT MANAGEMENT SYSTEM AND MEETING OF STATUTORY REQUIREMENTS IN ENGAGEMENT OF SECONDARY WORK FORCE
60.0	DETAILS OF MINIMUM PAYMENT TO WORKFORCE EMPLOYED BY CONTRACTOR
	SECTION - IX
61.0	STATUTORY REQUIREMENTS / SAFETY RELATED ASPECTS
	SECTION - X
62.0	GENERAL GUIDELINES TO SUPPLIERS (AS APPLICABLE) FOR ENVIRONMENT AND ENERGY COMPATIBILITY
63.0	GENERAL GUIDELINES TO SERVICE PROVIDERS (AS APPLICABLE) FOR ENVIRONMENT AND ENERGY COMPATIBILITY
	SECTION - XI
64.0	CONDITIONS FOR MICRO AND SMALL ENTERPRISES (MSEs)
65.0	CONDITIONS FOR START-UP COMPANIES
66.0	POLICY TO PROVIDE PURCHASE PREFERENCE (LINKED WITH LOCAL CONTENT) PP-LC.
67.0	TERMS AND CONDITIONS FOR BIDDERS FROM A COUNTRY SHARING AND BORDERS WITH INDIA



GENERAL CONDITIONS OF CONTRACT (GCC)

SECTION - I

1.0 DEFINITIONS :

- 1.1 The following expressions hereunder and elsewhere in the Contract Documents used, unless objectionable to the subject or context thereof, shall have the following meanings hereunder respectively assigned to them, namely;
- 1.2 The "OWNER" means Mangalore Refinery & Petrochemicals Limited a company incorporated in India having its registered office at Mangalore, Karnataka and shall include its successors and assignees
- 1.3 "Acceptance of Tender" shall mean the Acceptance of Tender issued by the OWNER to the CONSULTANT , and shall include a letter, e-mail or fax of acceptance or other notification of award of work, and a detailed Letter of Acceptance.
- 1.4 "Approval" shall mean the written and signed approval of the OWNER or of Engineer-in-Charge or Consultant authorized in this behalf by the OWNER, and with respect to a plan or drawing shall include an approval subject to the limitation(s) specified in such approval.
- 1.5 "Approval" shall mean an approval to proceed with the work covered by plans or drawings subject to certain limitation(s) as specified in such approval.
- 1.6 The "Contract" shall mean the agreement between the parties as derived from the Contract Documents.
- 1.7 The "CONSULTANT " shall mean Individual, Agency, Firm or Company (whether incorporated or not) selected by the OWNER for the performance of the Contract and shall include its legal representatives, successors and permitted assigns.
- 1.8 The "Contract Documents" shall means collectively the Tender Document. Designs. Drawings or Specifications, agreed variations, if any, and such other document constituting the tender and acceptance thereof.
- 1.9 "Completion" or "Final Completion" shall mean the successful provision of all materials and inputs and the successful completion and conclusion of all activities required in all respects to complete the contractual works in accordance with the contract, but shall not include the obligation to rectify defects during the Defect Liability Period.
- 1.10 "Completion Certificate" shall mean the Completion Certificate issued by the Engineer-in-Charge in accordance with the provisions hereof.
- 1.11 "Commissioning" of a Plant or Unit shall mean pressing into service the unit(s), equipment(s), vessels, pipeline(s), machinery and systems and sub-systems comprising the Plant, in accordance with the approved Operation Manual and as per procedures recommended by the Designer/Process Licensor or Supplier thereof, and approved by the OWNER, after successful trial runs of the Plant/Unit.
- 1.12 "Consultant" shall mean the Consultant appointed by the OWNER for the Project/job or the Works.
- 1.13 "Consumables" shall mean all items which are consumed in the execution of the Work, without being directly incorporated in the Work, such as fuel, electricity, water, welding rods, electrodes and utilities.
- 1.14 "Defect Liability Period" shall mean the defect liability period as specified in the Contract.
- 1.15 The "Engineer-in-Charge" shall mean the Engineer or other officer of the OWNER, Consultant or other organization for the time being nominated by the OWNER in writing to act as Engineer-in-Charge for the purpose of the Contract or any specific works.



- 1.16 "Final Certificate" shall mean the final certificate issued by the Engineer-in-Charge in accordance with the provisions hereof.
- 1.17 "General Manager" shall mean the General Manager or other Chief Executive (howsoever designated) of the Project to which the Contract relates, and if there is no such separate Chief Executive, shall mean the Executive Director (if any) or the General Manager, as the case may be, of the Refinery, Unit or Department of the OWNER to which the Project relates.
- 1.18 "Guarantee tests" shall mean all tests, undertaken after the Plant goes into operation and has stabilized, for ensuring that the functioning of the Plant meets all guarantees, as regards throughput, quality and magnitude/quantity of output, at the final stage as well as at the stipulated interim stages of operation/process, as well as in respect of consumption of utilities, chemicals and catalysts, etc.
- 1.19 "Job Site" shall mean any site at which the work is to be performed by the CONSULTANT, and shall include a part or portion of the job site.
- 1.20 "Manuals" shall mean the Erection and Installation Manual of the various equipment and machinery forming part of the Work(s) or Plant(s)/Unit(s) as well as the Operation and Maintenance Manuals thereof.
- 1.21 "Materials" shall mean all materials, plant, machinery, instruments, components, equipments, sub-assemblies and assemblies, parts, spares and other items or things required for permanent incorporation in the works.
- 1.22 Deleted
- 1.23 "Order" and "Instruction" shall respectively mean any written Order or Instruction given by the Engineer-in-Charge or Site Engineer within the scope of their respective powers in terms of the Contract.
- 1.24 "Plans" and "Drawings" shall mean and include all technical documentation such as maps, sketches, designs, drawings, plans, details, charts, schedules, tracings, prints, computer outputs, printouts, and manuals, relating to the work forming the subject matter of the contract, including but not limited to those forming part of the Tender Documents, Offer Documents, and working drawings and details, together with amendments/alterations/ revisions/ modifications thereto, as may have been approved by and/or furnished by the OWNER, the Engineer-in-Charge and/or the Consultant, as well as "As-Built" drawings to be submitted by the CONTRACTOR, as required under the contract.
- 1.25 "Pre-commissioning" shall mean the activities to be taken up before the taking up of Start-up, Commissioning and trial runs of the Plant/Unit, and shall include, without being limited to, all operations such as checking of all systems, subsystems, piping and vessels, flushing with air, water and steam, air-blowing and steam-blowing, system pressure and leak tests, purging with inert gas as required, checking all electrical equipment for earthing/ resistances, operability tests and cold run on all operating equipment, vessels and systems individually and in combination, integration of all control systems with one another and with the main control system, and completion of all operations detailed under the head, "COMPLETION OF CONSTRUCTION".
- 1.26 "Progress Schedule" shall mean the Progress Schedule established by the CONSULTANT and approved by the Engineer-in-Charge for completion of the work(s) within the time schedule in accordance with the provisions hereof and failing such Progress Schedule, shall mean the Progress Schedule established by the Engineer-in-Charge in accordance with the provisions hereof.



- 1.27 "Performance Test(s)" shall mean all tests meant to ensure that the Plant(s)/Unit(s) is/are in all respects in accordance with the requirements of the Contract and that the Plant functions properly and smoothly, in all respects as per the approved design parameters, within the permissible tolerances, and satisfies all the stipulated operating parameters, and will include the Guarantee Tests.
- 1.28 "Project" shall mean the project embracing the work(s) forming the subject matter of the Contract.
- 1.29 The "Site Engineer" shall mean the Engineer(s)/Officer(s) for the time being designated by the Engineer-in-Charge as his representative(s) in writing, and authorized by him to assist him in performing his duties and functions for the purpose of the Contract.
- 1.30 "Plant" or "Unit" shall mean the grouping of and assembly of systems, subsystems, machinery, equipment, piping and associated facilities, designed to function as a cognizable part of the Project Facility whether alone or in conjunction with other Plants/Units and Facilities.
- 1.30 "Schedule of Rates" or "Price Schedule" shall mean the Schedule of Rates or Price Schedule annexed to the Acceptance of Tender, and shall also include a lump sum price.
- 1.31 The "Specification(s)" shall mean the various specifications as set out in the Specifications forming part of the Tender Documents and as referred to and derived from the Contract and any order(s) or instruction(s) thereunder, and in the absence of any specifications as aforesaid covering any particular work or part or portion thereof, shall mean the Specifications and Codes of the Bureau of Indian Standards and other Organizations, including but not limited to British Standards Institution, ASTM, ASME, ANSI, API, AWS, AWWA, NACE, HEI, IEC, IBR, IEEE, EIL, CPWD, etc, with such modifications as may be applicable for the particular part(s) of the Contract, as decided by the Engineer-in-Charge and as per Standard Engineering and Industry Practice and/or as directed by the Engineer-in-Charge.
- 1.32 "Security Deposit" shall mean the Security Deposit as specified hereof and associated clauses there under.
- 1.33 "Subsystems" shall mean the further breakdown of a System into its subsections and sub-components, each designed to fulfill a precisely demarcated function or role in the working of the system.
- 1.34 "Start-up" shall mean all activities required to be performed after pre-commissioning and prior to trial operation and shall include final pre-commissioning inspection and check out of equipment, vessels and system(s) and supporting sub-system(s), initial operation of complete equipment and systems within the Plant/Unit to obtain necessary pre-trial operation data, confirmation and correction of calibration, shutdown inspection and adjustment and other steps required to be taken prior to and enable commissioning/trial operation.
- 1.35 "System" shall mean the breakdown of the Plant or Unit into specific sections and components, each designed to fulfill a precisely demarcated function or role in the working of the Plant/Unit (Examples: Fresh water system, circulating water system, steam and power generation and distribution systems, fuel system, effluent system in a Power Plant.)
- 1.36 "Time Schedule" shall mean the Time Schedule for final completion of the Works or commissioning of the Plant(s)/Unit(s), as the case may be, incorporated in the Contract or as may be extended by the OWNER or Engineer-in-Charge pursuant to the provisions hereof and shall include interim time schedules set up for achieving interim/phase-wise/stage-wise progress/completion/ testing/ commissioning/ handing over, as may be prescribed by the OWNER/ Engineer-in-Charge, within the overall Time Schedule as originally envisaged or as extended.



- 1.37 The "Total Contract Value" shall, up to calculation of the entire remuneration due to the CONSULTANT in terms of the contract on successful completion of the work, mean the Total Contract Value as specified in the Acceptance of Tender, and after calculation of the entire remuneration due to CONSULTANT under the contract on successful completion of the contract, shall mean the totality of such remuneration.
- 1.38 "Utilities" shall mean power, electricity, gas and other sources of energy, water, earth and other things whatsoever (other than materials and consumable(s)) required for or in the performance of the work(s).
- 1.39 "Work", "Scope of Work", "Service", and "Scope of Services" shall mean the totality of the work, services and activities to be performed or undertaken and the totality of the responsibilities to be discharged, as envisaged by expression or implication in the contract and shall include all inputs required for such performance and discharge including (but not limited to) know-how, design/engineering inputs, preparation and supply of drawings and details, project management (including pre-construction activities, tendering, procurement, inspection and expediting), construction supervision, pre-commissioning, start-up and commissioning and supply of consumables, labour, construction and other requisite machinery and equipment, utilities and inputs required for, relative or incidental to and/or in connection with the performance of the contract up to completion (including testing, commissioning, handing over, troubleshooting, rectification, maintenance and defect liabilities).

SECTION – II

2.0 LOCATION AND ACCESS OF SITE:

- 2.1 The work site is located within MRPL Refinery complex, Mangaluru / Refer Exhibit -1.

3.0 SCOPE OF WORK:

- 3.1 The scope of the work covered in this tender shall be as specified in the various Technical Specifications/SCC/Exhibit - 2. It is, however, explicitly understood and confirmed by the CONSULTANT that the scope as described in the TENDER DOCUMENT is not limiting, in so far as the responsibilities of the CONSULTANT shall include, inter-alia, carrying out any and all works and providing any and all facilities those are required in accomplishing the task, complying fully with all requirements as are envisaged of it, complete in all respects and satisfying all performance and guarantee requirement stated or implied from the contents of the BIDDING documents. **Note: Please refer EXHIBIT- 2 (for SCC, Tech specifications/conditions) and Price bid.**

4.0 CONSTRUCTION POWER & WATER (If APPLICABLE):

Please refer Exhibit -5

5.0 ACCOMMODATION:

- 5.1 MRPL shall not provide any accommodation for CONSULTANT / his staff /workers. Special instruction if any in this regard, please refer SCC/ Scope of work.

6.0 TRANSPORTATION:

- 6.1 MRPL shall not arrange any transportation (to and fro) to MRPL for CONSULTANT / his staff /workforce. Special instruction if any in this regard, please refer SCC/ Scope of work.

7.0 CONSTRUCTION EQUIPMENT :Deleted

8.0 PUTTING UP OF BUILDINGS ON PROJECT SITE (If applicable) :

- 8.1 The CONSULTANT shall put up temporary structures (Portable cabin) as required by him for his office space only on the area allocated to him on the Project Site. No tea



stalls/canteens should be put up or allowed to be put up by CONSULTANT in plant area without written permission of the owner.

- 8.2 No Person other than authorised watchman shall be allowed to stay in the plant area after completion of the days work without prior written permission of the Engineer-in-charge.

SECTION - III

9.0 GENERAL GUIDELINES (As applicable) :

- 9.1 Every tenderer must quote strictly in accordance with the conditions and specifications prescribed by MRPL. Special conditions (if any) submitted along with the tender documents by the bidder will not be applicable to this Tender, in case they are in conflict with any of our terms and conditions.
- 9.2 All entries in the tender must be written in permanent ink or typewritten without use of eraser or overwriting. Corrections if any, should be attested under the full signature of the Bidder.
- 9.3 All tenderers are required go through the GCC carefully and submit a declaration statement as enclosed in tender as token of having read, understood and accepted the conditions, along with information called for by MRPL.
- 9.4 Company will not be responsible for loss or late /non-receipt of tender documents.
- 9.5 MRPL reserve the right to assess bidder's capability and capacity to execute the work using in-house information and by taking into account other aspects such as concurrent commitments and past performance, etc.
- 9.6 Submission of authentic/genuine documents is the prime responsibility of the bidder. Wherever MRPL has concern or apprehension regarding the authenticity/genuineness of any document, MRPL reserves the right of obtaining the documents cross verified from the document issuing authority.
- 9.7 MRPL reserve the right to complete the evaluation based on the details furnished by the bidder in the first instance along with their bid without seeking any additional information.
- 9.8 Bidder should have independent ESI & PF code allotted by Employee State Insurance Corporation and Employees Provident Fund Organization. The details should be enclosed along with the technical bid. However, in the event of non-availability of PF code at the time of submitting the bid, the successful bidder shall obtain the same within 45 days from the date of commencement of the work and an undertaking to this effect shall be enclosed.
- 9.9 The wages paid by the CONSULTANT to their employees / workmen shall be fair and in no case be less than the wages prescribed by the appropriate Government under the Minimum Wages Act, 1948 and all provisions of Regulation of Contract Labour Act. In addition to the minimum wages prescribed by the appropriate government/authorities, the successful bidder shall pay employer contribution of PF, ESI, Leave wages, Bonus as per bonus act, MRPL special allowance as per **clause 60.0**. All safety gadgets, Uniform shall be given to the employees by the bidder as per F&S Dept requirements.
- 9.10 All tenderers are required to give details in the Performa attached and attach to Technical bid.
- 9.11 **DIFFERENCE IN MEANINGS/TERMS:** In case of any difference of any of the terms and conditions either in the meaning or understanding or contradictory terms or conditions at different places/portions in this document, the more stricter terms favouring MRPL will apply. The bidder shall also seek clarifications on such issues from MRPL before submission of the quotes.



10.0 CORRECTNESS OF DOCUMENT:

10.1 It shall be understood that every endeavour has been made to avoid error which can materially affect the basis of this tender and the successful tenderer shall take upon himself and provide for risk of any error which any subsequently be discovered and shall make no subsequent claim on account thereof no advantage is to be taken by the tenderer successful Or otherwise of any clerical error of mistake which may occur in the general specification, schedules, plans of tender forms supplied to the tenderer.

11.0 EARNEST MONEY DEPOSIT :

11.1 Incomplete tender/ tenders **without requisite / insufficient** EMD will be rejected. The Company reserves the right to reject a tender or all the tenders without assigning any reason whatsoever.

11.2 EMD may be paid in one of the following forms in a separate sealed cover.

- i. Demand drafts or Pay Order drawn on Scheduled Bank in favour of MRPL, Mangalore.
- ii. Bank Guarantee in prescribed format (enclosed) which is enclosed, executed by scheduled / Nationalised Bank and valid for a period of 180 days.
- iii. EMD to be sent to the concerned officer before due date/ time.

11.3 Company will not be responsible for loss or late / non receipt of EMD.

- i. No interest shall be payable on Earnest Money Deposit.
- ii. Late receipt of EMD will be summarily rejected.
- iii. No Cheques will be accepted towards EMD.

11.4 Tender will be summarily rejected under following circumstances

- i) EMD submitted in form of cheque.
- ii) The name of tender mentioned in the BG is different from the tender for which bids have been invited.
- iii) The firm on whose behalf the BG has been furnished is different from the bidder
- iv) The EMD is not of prescribed/requisite value.
- v) The validity of the BG is less than the stipulated period.

11.5 Earnest Money is liable to be forfeited if tenderer.

- i) Withdraws or modifies offer in full or part during the validity period.
- ii) Failure of the bidder to honour their offer.
- iii) Non acceptance of Purchase / Work Order placed by MRPL.
- iv) Does not Confirm of acceptance of order within the stipulated time after placement of order.
- v) Inability to perform satisfactorily after receipt of order in case of successful bidder.
- vi) If document(s)/certificate(s) submitted along with the bid are found false/fake, fabricated, incorrect information.
- vii) The name of the tender mentioned in the BG is different from the tender for which bids have been invited.
- viii) The firm on whose behalf the BG has been furnished is different from the bidder.

11.6 The following are exempted from payment of EMD.

- i. The unit is registered with NSIC for the item tendered.
- ii. In- line with the Government Directives, Small Scale Industrial Units registered with National Small scale Industries Corporation (NSIC) under the single point registration scheme shall be exempted from submitting EMD for items registered with NSIC and upto the monetary limit specified in the registration certificate.
- iii. MSE (Micro & Small Enterprises) registered with DIC.



- iv. MSEs who are having Udyog Aadhar Memorandum.
- v. PSU'S are exempted from payment of EMD.

11.7 Refund of EMD :

- i. If the successful tenderer commences supplies / work and also lodges the security deposit in the manner prescribed and within the period specified, MRPL shall return to him Earnest Money Deposit, paid by him without any interest thereon.
- ii. Earnest Money Deposit will be refunded to all unsuccessful tenderers after finalisation of the Tender.

12.0 BID VALIDITY / BID OPENING :

- 12.1 The rate quoted against this tender shall be valid for a period as mentioned in the NIT (as specified in from the date of opening of tenders and once the quotation is accepted and order placed on the successful tenderers, the rate shall be valid for the full period of the contract (INCLUDING THE EXTENDED PERIOD, IF OPTED BY MRPL).
- 12.2 Tenderers are requested to carefully study the entire tender document and the conditions so specified before quoting their rates, no alteration in the tender rates quoted will be allowed.
- 12.3 The Technical bid opening for Public Tenders will be done on the same day of Bid closure.
- 12.4 The price bid of the qualifying parties will be opened online as per MRPL Procedures for e-procurement tenders.

13.0 RIGHT OF OWNER TO ACCEPT OR REJECT TENDER:

- 13.1 The right to accept the tender will rest with the OWNER. The OWNER, however, does not bind himself to accept the lowest tender, and reserves to itself the authority to reject any or all the tenders received without assigning any reason whatsoever. At the option of the Owner, the work for which the tender had been invited, may be awarded to one CONSULTANT or split between more than one bidders, in which case the award will be made for only that part of the work, in respect of which the bid has been accepted. The quoted rates should hold good for such eventualities. Tenders in which any of the particulars and prescribed information are missing or are incomplete in any respect and/or the prescribed conditions are not fulfilled are liable to be rejected. The Tender containing uncalled for remarks or any additional conditions are liable to be rejected. Canvassing in connection with tenders is strictly prohibited and tenders submitted by the Tenderers who resort to canvassing will be liable to rejection.

14.0 TIME SCHEDULE/MOBILISATION/COMPLETION PERIOD – Refer EXHIBIT-3 :

- 14.1 The WORK shall be executed strictly as per the TIME SCHEDULE specified in TENDER/CONTRACT Document. The period of construction given in Time Schedule includes the time required for mobilisation as well as testing, rectifications if any, retesting and completion in all respects to the entire satisfaction of the ENGINEER-IN- CHARGE.
- 14.2 A joint programme of execution of the WORK will be prepared by the CONSULTANT based on priority requirement of this project. This programme will take into account the time of completion mentioned in 14.1 above and the time allowed for the priority works by the ENGINEER-IN-CHARGE.
- 14.3 Monthly/weekly construction programmes will be drawn up by the Engineer-in-charge jointly with the CONSULTANT based on demand/ availability of materials, work fronts etc. The CONSULTANT shall scrupulously adhere to the targets/programmes by deploying adequate personnel, survey instruments, construction equipment, tools and tackles and also timely supply of required materials coming within his scope of supply as per contract. In all matters concerning the extent of targets set out in the monthly/weekly programe and



the degree of achievements, the decision of Engineer-in-charge will be final and binding on the CONSULTANT .

- 14.4** If required by MRPL, CONSULTANT shall give every day report on deployment of category-wise labour and equipment along with the progress of work done on previous day in the proforma prescribed by the Engineer-in-Charge.

15.0 SITE ORGANISATION :

- 15.1** The tenderer shall submit the details of organisation proposed by him at site of work for the implementation of the works under the contract, together with bio-data of the key personnel. The CONSULTANT shall however without prejudice to his overall responsibility of execute and complete the works as per specifications and time schedule progressively deploy adequate qualified and experienced personnel together with skilled/unskilled manpower and augment the same as decided by Engineer-in- Charge depending on the exigencies of work to suit the construction schedule without any additional cost to owner.

16.0 UNDERGROUND AND OVERHEAD STRUCTURES :

- 16.1** The CONSULTANT will familiarise himself with and obtain information and details from the Owner in respect of all existing structures, overhead lines, existing pipelines and utilities existing at the job site before commencing work. The CONSULTANT shall execute the work in such a manner that the said structures, utilities, pipelines etc are not disturbed or damaged and shall indemnify and keep indemnified the Owner from and against any destruction thereof or damages thereto.

17.0 CO-ORDINATION WITH OTHER AGENCIES :

- 17.1** The work shall be carried out in such manner that the work of other agencies operating at the site is not hampered due to any action of the CONSULTANT. The CONSULTANT will be responsible for ensuring proper co-ordination with other agencies. In the event of any dispute between the CONSULTANT and any other agency employed at the job site arising out of or related to the performance of the work, the decision of the Engineer-in-charge shall be final and binding on the CONSULTANT.

18.0 NOTE TO SCHEDULE OF RATES:

- 18.1** The Schedule of Rates should be read in conjunction with all the other sections of the tender.
- 18.2** The tenderer shall be deemed to have studied the DRAWINGS, SPECIFICATIONS and details of work to be done within TIME SCHEDULE and to have acquainted him of the condition prevailing at site.
- 18.3** Rates must be filled in the Schedule of Rates of original Tender Documents. If quoted in separate typed sheets no variation in item description or specification shall be accepted. Any exceptions taken by the tenderer to the Schedule of Rates shall be brought out in the terms and conditions of the offer.
- 18.4** The quantities shown against the various items are only approximate. Any increase or decrease in the quantities shall not form the basis of alteration of the rates quoted and accepted.
- 18.5** The Owner reserves the right to interpolate the rates for such items of work falling between similar items of lower and higher magnitude.

19.0 ACCEPTANCE OF TENDER:

- 19.1** The Owner reserves the right to reject, accept or prefer any or all or part of the Tender or to annul the bidding process at any time prior to award of Contract, without thereby incurring any liability to the affected Bidders.



- 19.2** Although ordinarily the lowest responsive bid amongst the bids submitted by tenderers and considered by the Owner as qualified and competent shall be preferred, the Owner reserves the right not to accept the lowest bid if in its opinion this would not be in the interest of the work.
- 19.3** Tenders in which any of the particulars and prescribed information is missing or is incomplete in any respect and/or the prescribed conditions are not fulfilled shall be considered non-responsive and are liable to be rejected.
- 19.4** The Owner may waive any minor infirmity or non-conformity or irregularity in a bid which does not constitute a material deviation, provided such waiver does not prejudice or affect the relative ranking of any Bidder.
- 19.5** The price bid of only those Bidders will be opened who are considered techno-commercially acceptable to the Owner. Date of opening of the price bid shall be informed to the technically qualified Bidders.
- 19.6** The decision of Owner for acceptance of tender shall be final.
- 20.0** **ISSUE OF WORK ORDER/LOI :**
- 20.1** Work order for the awarded work shall be issued after award of works, which is intimated to the successful tenderer by a Letter of Acceptance (LOA) / Letter of Intent (LOI) / Order. Until the final contract document/W.O is prepared and executed, this tender document together with annexed documents, modifications, deletion, agreed upon by the Owner and the Tenderer's acceptance thereof shall constitute a binding contract between the successful tenderer and the owner based on the terms contained in the above said documents and the finally submitted and accepted price schedule.
- 20.2** The Work order / Purchase order / Contract shall consist of the following:
- (a) Letter of Acceptance / Letter of Intent along with its enclosures.
 - (b) Tender document with its enclosures.
 - (c) Agreement on Stamp paper, at MRPL discretion.
- 20.3** The statement of agreed deviation shall be prepared based on the final terms and conditions and shall be enclosed along with LOA/LOI/Order and all correspondence and minutes of meeting held between the owner and the tenderer prior to the issue of LOA/LOI/Order shall be treated as NULL AND VOID. Any deviation or stipulation made and accepted by the owner after the award of jobs shall be treated as amendments to the contract documents.

SECTION – IV

21.0 INTERPRETATION OF CONTRACT DOCUMENTS:

- 21.1** The several Contract documents forming the Contract are to read together as a whole and are to be taken as mutually explanatory.
- 21.2** Notwithstanding the sub divisions of the document into these separate sections and volumes every part of each shall be deemed to be supplementary to and complementary of every other part and shall be read with and into the contract so far as it may be practicable to do so.
- 21.3** In case of an irreconcilable contradiction in the commercial terms or conditions to the extent that the two provisions cannot co-exist, the following shall prevail in order of precedence.
- i) Contract Agreement
 - ii) Detailed Letter of Acceptance/Purchase Order/Work Order/Contract
 - iii) Statement of Agreed Variations
 - iv) Special Conditions of Contract
 - v) Instructions to Bidders



- vi) Price Schedule
 - vii) General Conditions of Contract
 - viii) Any other documents forming part of the Contract.
- 21.4** Where any portion of the Special Conditions of Contract (SCC) is repugnant to or at variance with any provisions of the General Conditions of Contract then unless a different intention appears, the provision of the Special Conditions of Contract shall be deemed to override the provisions of the General Conditions of Contract only to the extent such repugnancies or variations in the Special Conditions of Contract as not possible of being reconciled with the provisions of General Conditions of Contract.
- 21.5** Wherever it is stated anywhere in this tender document that such and such a supply is to be effected or such and such a work is to be carried out, it shall be understood that the same shall be effected/carried out by the CONSULTANT at his own cost, unless a different intention is specifically and expressly stated herein or otherwise explicit from the context.
- 21.6** The materials, design and workmanship shall satisfy the relevant Indian Standards, the Technical Specifications contained herein and codes referred to. Where the job specifications stipulate requirements in addition to those job contained in the standard codes and specifications, these additional requirements shall also be satisfied.
- 21.7** In case of an irreconcilable conflict between Indian or other applicable standards. General Conditions of Contract, Special Conditions of Contract, Specifications, Drawings and/or Schedule of Rates, the following shall prevail to the extent of such irreconcilable conflict in order of precedence.
- i) Formal Contract
 - ii) Detailed Letter of Acceptance
 - iii) Statement of Agreed Variations
 - iv) Job specifications / Scope of Work
 - v) Drawings
 - vi) Technical / Material Specifications
 - vii) Quality Assurance Procedures
 - viii) Applicable Codes & Standards
 - ix) Special Conditions of Contract
 - x) General Conditions of Contract
 - xi) Price Schedule
 - xii) Instructions to Bidders
 - xiii) Any Other documents forming part of contract
- 21.8** It will be the CONSULTANT 's responsibility to bring to the notice of Engineer-in-charge any irreconcilable conflict in the Contract documents before starting the work(s) or marking the supply / service with reference to which the conflict exists.
- 21.9** In the absence of any Specifications covering any material, design or work(s) the same shall be performed/supplied/executed in accordance with standard Engineering practice as per the instructions/directions of the Engineer-in-charge, which will be binding on the CONSULTANT .
- 21.10** Headings and Marginal Notes: All headings and marginal notes to the clauses of these General Conditions of Contract or to the SPECIFICATIONS or to any other Tender Document are solely for the purpose of giving a concise indication and not a summary of the contents thereof, and they shall never be deemed to be part thereof or be used in the interpretation or construction thereof the CONTRACT.
- 21.11** Singular and Plural: In CONTRACT DOCUMENTS unless otherwise stated specifically, the singular shall include the plural and vice versa wherever the context so requires.
- 22.0** **SECURITY DEPOSIT (applicable for order value Above Rs 10.00 Lakhs) :**
- 22.1** The Successful tenderer will have to deposit with MRPL (within 15 days of award of work order) an amount equivalent to **10 % of Order value** interest free security deposit



- 22.2 towards due & satisfactory performance of contract, such SD shall be limited to annual order value in case of Annual rate contract only.
- 22.3 SD shall be submitted In the form of Pay order or Demand Draft in favour of MRPL drawn on a Nationalised / scheduled bank payable at Mangalore on which no interest will be payable.

OR

In the form of Bank Guarantee from Nationalised / scheduled bank acceptable to MRPL as per company standard Performa which is enclosed. The Bank Guarantee will be valid for ONE year, renewable every year, for the balance period of the contract.

The irrevocable Bank Guarantee (BG) in the prescribed format if submitted against PBG/SD. shall be subject to verification from the issuing Bank, the email ID of bank for the same must be incorporated in the BG.

The BG issued by the issuing Bank on behalf of Bidder/Contractor/Supplier in favour of "Mangalore Refinery and Petrochemicals Limited" shall be in paper form and also be made available under the "Structured Financial Messaging System" (SFMS).

A separate advice of the BG will invariably be sent by the issuing bank to the beneficiary's Bank through SFMS and SFMS transmission message reference number (currently 32 digits code) is to be sent along with BG directly to MRPL through speed post/regd. Post.

The details of beneficiary for issue of BG under SFMS platform is furnished below:

Name of Beneficiary: Mangalore Refinery and Petrochemicals Limited

Beneficiary Bank, Branch and address: Union Bank of India (Erstwhile Corporation Bank), MRPL Project Site, Kuthethoor Post Mangalore 575030, Karnataka

IFSC code: CORP0000592

SWIFT Code: CORPINBB

MICR Code: 575017015

Any bank guarantee submitted in physical mode which cannot be verifiable through SFMS will not be accepted under any circumstances.

- 22.4 MRPL is entitled without being bound to do so, to adjust the whole or any portion of the security deposit towards the recovery of any amount due to MRPL from the successful tenderer. The Security Deposit or such portion thereof that has not been adjusted towards recovery of amount due from the successful tenderer will be refunded within 15 days of on satisfactory completion of the contract or after the expiry of DEFECT LIABILITY PERIOD wherever applicable. No interest is payable by MRPL to the successful tenderer on the security deposit.

- 22.5 Security deposit shall be forfeited in case the vendor fails to execute the order.

23.0 RECOVERY OF SUMS DUE :

- 23.1 Whenever any claim against the CONSULTANT for payment of a sum of money arises out or under the contract, the Owner shall be entitled to recover such sums from any sum then due or which at any time thereafter may become due from the CONSULTANT under this or any other contract with the Owner and should this sum be not sufficient to cover the recoverable amount the Vendor shall pay to the Owner on demand the balance remaining due.

24.0 FORCE MAJEURE CLAUSE :

24.1 Circumstances leading to force majeure;

- a) act of terrorism;
b) riot, war, invasion, act of foreign enemies, hostilities (whether war be declared or not),



- civil war, rebellion, revolution, insurrection of military or usurped power;
- c) ionising radiation or contamination, radio activity from any nuclear fuel or from any nuclear waste from the combustion of nuclear fuel, radioactive toxic explosive or other hazardous properties of any explosive assembly or nuclear component;
 - d) epidemics, earthquakes, flood, fire, hurricanes, typhoons or other physical natural disaster, but excluding weather conditions regardless of severity; and
 - e) freight embargoes, strikes at national or state-wide level or industrial disputes at a national or state-wide level in any country where Works are performed, and which affect an essential portion of the Works but excluding any industrial dispute which is specific to the performance of the Works or the Contract.

For the avoidance of doubt, inclement weather, third party breach, delay in supply of materials (other than due to a nationwide transporters' strike) or commercial hardship shall not constitute a Force Majeure event.

24.2 Notification of Force Majeure;

CONSULTANT shall notify within [10(ten)] days of becoming aware of or the date it ought to have become aware of the occurrence of an event of Force Majeure giving full particulars of the event of Force Majeure and the reasons for the event of Force Majeure preventing the Affected Party from, or delaying the Affected Party in performing its obligations under the Contract.

24.3 Right of either party to terminate;

If an event of Force Majeure occurs and its effect continues for a period of 180 (one hundred eighty days) or more in a continuous period of 365 (three hundred sixty five) days after notice has been given under this clause, either Party may terminate the Contract by issuing a written notice of 30 (thirty) days to the other Party.

24.4 Payment in case of termination due to Force Majeure;

The Contract Price attributable to the Works performed as at the date of the commencement of the relevant event of Force Majeure.

The CONSULTANT has no entitlement and Owner has no liability for:

- a. any costs, losses, expenses, damages or the payment of any part of the Contract Price during an event of Force Majeure; and
- b. any delay costs in any way incurred by the CONSULTANT due to an event of Force Majeure. Time extension for such cases will be worked out appropriately.

25.0 PRICE REDUCTION SCHEDULE (PRS) FOR DELAYS EXECUTION OF CONTRACT:

25.1 If the successful tenderer commits any default or breach of terms and conditions of the Work Order to be placed on them or fail in the due performance thereof within the time fixed by the contract (which is the essence of the contract) and do not complete the entire supplies / work on the stipulated due date, MRPL shall be entitled to recover from the successful tenderer by way of compensation or Price Reduction schedule as specified in Exhibit 4 of the tender document.

25.2 PRS will be imposed on the cost of contract price of delayed in completing the work within the scheduled time, except however, where, in the judgment of MRPL the executed partial job/work quantity does not fulfil the operating need, PRS will be imposed on full value of the Work Order.

25.3 The parties agree that this is a genuine pre-estimate of the loss/damage which will be suffered by the Owner on account of delay on the part of the CONSULTANT and the said amount will be adjusted for the amount payable to the CONSULTANT, without there being any proof of the actual loss or damages having been caused by such delay/breach. The Owner shall be at liberty to adjust or deduct the said amount from any amount due to the CONSULTANT including Security Deposit.



25.4 Non Acceptance of PRS:

If the technically and commercially acceptable bidders are 3 or more, offers of other bidders, if any, who are taking deviation in commercial terms, shall be rejected though they are technically acceptable. However, if this tender result in less than 3 technically and commercially acceptable offer, then the offers of those bidders who are technically acceptable, but have taken deviation only in PRS clause, shall be considered after suitable loading for evaluation purpose as detailed below;

5% of the quoted basic price shall be added to the landed cost for evaluation purpose.

26.0 PENALTY CLAUSES:

26.1 Penalty shall be as specified in Exhibit 4 of the tender document. Penalty, subject to violation of terms attributable to the CONSULTANT, shall be levied in RA bills of the CONSULTANT on failure to comply with terms and conditions of the contract.

27.0 SUB-LEASING/OPERATION OF CONTRACT:

27.1 The successful tenderer shall not be allowed to sublet or assign the benefits of the Purchase/Work order placed on them by MRPL to any other party without prior written consent of the MRPL.

28.0 SUSPENSION OF WORKS :

28.1 Subject to the provisions of this contract, the CONSULTANT shall, if ordered in writing by the Engineer-In-Charge, or his representative, temporarily suspend the works or any part thereof for such written order, proceed with the work therein ordered to be suspended until, he shall have received a written order to proceed therewith. The CONSULTANT shall not be entitled to claim compensation for any loss or damage sustained by him by reason of temporary suspension of the works aforesaid. An extension of time for completion, corresponding with the delay caused by any such suspension of the works as aforesaid will be granted to the CONSULTANT should he apply for the same provided that the suspension was not consequent to any default or failure on the part of the CONSULTANT.

28.2 In case of suspensions of entire work, ordered in writing by Engineer-In-Charge, for a period of more than two months, the CONSULTANT shall have the option to terminate the contract.

29.0 CANCELLATION :

29.1 MRPL reserves the right to cancel the Order or any part thereof and shall be entitled to rescind the contract wholly or in a written notice to the vendor at any time if:

The successful tenderer shall commit a breach of any of the conditions stipulated contract and fail to remedy such breach within four days of the receipt of the written notice from MRPL in this regard.

Upon

- iii. The death or adjudication as insolvent of the successful tenderer, if he/she be an individual.
- iv. The liquidation, whether voluntary or passing of the effective resolution for winding up of the successful tenderer if it be a company.

29.2 If any successful tenderer or any partner in the firm of the successful tenderer shall be convicted of any criminal offence.

29.3 If a receiver is appointed of any property or assets of the successful tenderer.

29.4 If the work/ services are no more required by MRPL.

29.5 If the license issued to the successful tenderer by the relevant authorities for modification filling and storage of bitumen supplied by MRPL is cancelled or revoked.



- 29.6** If the successful tender deliberately contaminates or tempers with quality or product supplied by MRPL.
- 29.7** MRPL will be at liberty to short close the contract work order without assigning any reason whatsoever by giving a notice of 15 days.
- 29.8** Specified delivery schedule/ completion period is not adhered to beyond 3 months from due date unless specifically agreed by MRPL.
- 29.9** Laid down specifications are not adhered to or when the performance of the contract is unsatisfactory.
- 29.10** Major contractual terms and conditions are violated insolvency of the supplier.
- 29.11** The MRPL right to cancel the contract under the terms, aforesaid shall be without prejudice to any of its other rights and remedies against the successful tenderer In the event of MRPL cancelling the contract, it shall not be liable to pay for any loss or compensation in respect of such cancellation

30.0 TERMINATION :

- 30.1** The OWNER shall be entitled to terminate the Contract by written notice at any time during or after the occurrence of any one or more of the following events or contingencies, namely:
- i) Failure to start the work within 10 (ten) days of handing over the job site to the CONSULTANT .
 - ii) Failure to provide at each job site sufficient labour, material, equipment, machinery, temporary work and/or facilities required for the proper and/or due execution of the work or any part thereof;
 - iii) Failure to execute the works or any of item in accordance with the Contract;
 - iv) Disobedience of any order or instruction of the Engineer-in-Charge and/or Site Engineer;
 - v) Negligence in carrying out the works or carrying out of work found to be unsatisfactory by the Engineer-in-Charge;
 - vi) Abandonment of the works or any part thereof;
 - vii) Suspension of the entire works or any part thereof, for a period of 14 (fourteen) days or more without due authority from the OWNER or Engineer-in-Charge.
 - viii) Commission, permission or sufferance of any other breach of any of the terms, conditions or provisions of the Contract on the part of the CONSULTANT to be paid, performed and/or observed;
 - ix) Failure to deposit the Initial Security Deposit within 10 (ten) days of receipt by the CONSULTANT of Acceptance of Tender;
 - x) If the CONSULTANT is incapable of carrying out the work.
 - xi) If the CONSULTANT misconducts himself in any manner.
 - xii) Dissolution of the CONSULTANT (if a firm) or commencement of liquidation or winding up (whether voluntary or compulsory) of the CONSULTANT (if a company) or appointment of a receiver or manager of any of the CONSULTANT 's assets and/or insolvency of the CONSULTANT (if a sole proprietorship) or any Partner of the CONSULTANT (if a firm);
 - xiii) Distress, execution, or other legal process being levied on or upon any of the CONSULTANT 's goods and/or assets.
 - xiv) Death of a CONSULTANT (if an individual).



- xv) If upon any change in the Partnership/constitution of a CONSULTANT 's organization (if a Partnership), the OWNER shall refuse to continue the contract with the re-constituted firm.
- xvi) If the CONSULTANT or any person employed by him shall make or offer for any purpose connected with the Contract any gift, gratuity, royalty, commission, gratification or other inducement (whether money or in any other form) to any employee or agent of the OWNER.

30.2 TERMINATION FOR CONVENIENCE:

Notwithstanding anything contained in the Contract, the Employer may, by 30 (Thirty) days written notice, terminate the Contract in whole or in part. In addition to the payment mentioned at clause 30.3, the Service Provider shall be compensated for de-mobilization and other costs incurred at mutually negotiated terms. In case of such termination, the obligation of the Employer to pay, shall be limited to the extent of work/job completed by the Service Provider as per provision of the Contract upto the date of termination, subject to the Service Provider complying with other terms of the Contract. Notwithstanding the termination of the Contract, the parties shall continue to be bound by the provisions of this Contract that reasonably require some action or forbearance after such termination.

30.3 AMOUNT PAYABLE IN CASE OF TERMINATION:

In all cases of termination herein set forth, the obligation of the Employer to pay, shall be limited to the extent of service rendered by Service Provider as per provision of the Contract upto the date of termination, subject to the Service Provider complying with other terms of the Contract. Notwithstanding the termination of the Contract, the parties shall continue to be bound by the provisions of this Contract that reasonably require some action or forbearance after such termination.

31.0 INSPECTION / OPERATION CONTRACT:

- 31.1 MRPL shall have free access to visit the bidder's premises/work area where the job/services are taking place and or inspect the same. The successful tenderer will be responsible for quality of all the services/job at all times under valid permits/as authorised by Engineer In-charge.

32.0 MAKE OF EQUIPMENTS/COMPONENTS :

- 32.1 Bidders shall procure and supply the items covered in their scope from the approved vendors. Wherever an item is specified or described by a particular brand name, manufacturer or vendor, the specific item mentioned shall be for establishing type, function and quality desired. Other manufacturer's products will be considered, provided sufficient information are furnished to the Employer to assess the products proposed as equivalent and acceptable. CONSULTANT shall take prior approval from Engineer-in-Charge for procuring such items which are not covered under approved vendor list.

33.0 QUALITY ASSURANCE SYSTEM (As applicable) :

- 33.1 The CONSULTANT shall include in his offer the Quality Assurance Programme containing the overall quality management and procedures which is required to be adhered to during the execution of contract. After the award of the contract, detailed quality assurance programme to be followed for the execution of contract under various divisions of works will be mutually discussed and agreed to.
- 33.2 The CONSULTANT shall establish document and maintain an effective quality assurance system as outlined in recognised codes.
- 33.3 Quality Assurance System plans/procedures of the CONSULTANT shall be furnished in the form of a QA manual. This document should cover details of the personnel responsible for the quality assurance. ,plans or procedures to be followed for quality control in respect of Design, Engineering, Procurement, Supply, Installation, Testing and Commissioning.



ENGINEERING, PROCUREMENT AND CONSTRUCTION MANAGEMENT (EPCM) SERVICES FOR INSTALLATION OF LPG AMINE ABSORBER SYSTEM IN PFCC UNIT AT MRPL, MANGALURU

The quality assurance system should indicate organizational approach for quality control and quality assurance of the construction activities at all stages of work at site as well as at manufacturer's works and despatch of materials.

- 33.4** The Owner/or their representative shall reserve the right to inspect/witness review any or all stages of work at shop/site as deemed necessary for quality assurance.
- 33.5** The CONSULTANT has to ensure the deployment of quality Assurance and Quality control Engineer(S) depending upon the quantum of work. This QA/QC group shall be fully responsible to carryout the work as per standards and all code requirements. In case Engineer-in-Charge feels that CONSULTANT 's QA/QC Engineer(S) are incompetent or insufficient CONSULTANT has to deploy other experienced Engineer(s) as per site requirement and to the full satisfaction of Engineer-In-Charge.
- 33.6** In case CONSULTANT fails to follow the instructions of Engineer-in-charge with respect to above clauses, next payment due to him shall not be released unless and until he complies with the instructions to the full satisfaction of Engineer-in-charge

34.0 TEST AND INSPECTION OF WORKS :

- 34.1** Inspection scope of the Consultant shall be as per Exhibit -2: Scope of services of this tender document.
- 34.2** The inspection requirement of the project shall be carried out as defined in Exhibit-2 Scope of services of this tender document:
- 34.3** CONSULTANT shall give prior notice sufficiently ahead of time to the Engineer-in-charge and also to the authorities to conduct inspection/to witness such test.
- 34.4** The work is subject to inspection at all times by the Engineer-in-Charge. The CONSULTANT shall carry out all instructions given during inspection and shall ensure that the work is being carried out according to the technical specifications of this tender, the technical documents and the relevant codes of practice furnished to him during the performance of the work.
- 34.5** Deleted.
- 34.6** Deleted
- 34.7** All results of inspection and tests will be recorded in the inspection reports, proforma of which will be approved by the Engineer-in-Charge. These reports shall form part of the completion documents.
- 34.8** For materials supplied by Owner, CONSULTANT shall carryout the tests, if required by the Engineer-in-charge and the cost of such tests shall be reimbursed by the Owner at actuals to the CONSULTANT or production of documentary evidence.
- 34.9** Inspection and acceptance of the work by the Engineer-in-charge shall not relieve the CONSULTANT from any of his responsibilities under this contract.

35.0 DEFECT LIABILITY (If Applicable): Refer Exhibit-7 of the tender document.

36.0 LIMITATION OF LIABILITY(Refer Article-23 of Form of Contract) :

- 36.1** The aggregate total liability of the CONSULTANT to Owner under the Contract shall not exceed the total Contract Price, except that this Clause shall not limit the liability of the CONSULTANT for following:
- In the event of breach of any Applicable Law;
 - In the event of fraud, willful misconduct or illegal or unlawful acts, or gross negligence of the CONSULTANT or any person acting on behalf of the CONSULTANT ; or
 - In the event of acts or omissions of the CONSULTANT which are contrary to the most elementary rules of diligence which a conscientious CONSULTANT would have followed in similar circumstances; or



- d) In the event of any claim or loss or damage arising out of infringement of Intellectual Property; or
- e) For any damage to any third party, including death or injury of any third party caused by the CONSULTANT or any person or firm acting on behalf of the CONSULTANT in executing the Works.
- 36.2** Neither Party shall be liable to the other Party for any kind of indirect nor consequential loss or damage like, loss of use, loss of profit, loss of production or business interruption which is connected with any claim arising under the Contract.
- 37.0 RISK PURCHASE CLAUSE :**
- In the event of CONSULTANT not accepting/not meeting the indent/order/contract placed by the Owner with in the stipulated time, then Owner would be free to use the services of any others and recover the difference in such services and additional expenses incurred by the Owner from the CONSULTANT .
- 38.0 COPY RIGHT /TRADE MARK OF MRPL RELATED DISCIPLINE:**
- 38.1** The successful tenderer shall not infringe, copy, imitate or otherwise deal with brand name, trade or merchandise marks or devices of design or copyright belonging to MRPL entitled to use or otherwise alter, deface or interface with the same or pass off other goods or describe others goods as the same as that of MRPL or having been manufactured of MRPL or otherwise prejudice alter or affect the copyright, trade or merchandise marks or certified packing or design or colour of the company's labels or specification or the price or weight or other codification that is marked on the packing or caused to be given by MRPL, it is expressly agreed that all trademarks, design and copyright shall vest in MRPL, and nothing contained in this offer shall have the effect of creating any right, title or interest in respect of the successful tenderer.
- 39.0 ROYALTY :(If applicable)**
- 39.1** All royalties etc., as may be required for any Borrow Areas including right of way et. to be arranged by CONSULTANT shall be deemed to have been included in the quoted prices.
- 39.2** CONSULTANT 's quoted rate should include the royalty on different applicable items as per the prevailing State Government rates. In case, owner is able to obtain the exemption of Royalty from the State Government, the CONSULTANT shall pass on the same to owner for all the items involving Royalty. Any increase in prevailing rate of Royalty shall be borne by the CONSULTANT at no extra cost to the Owner. The CONSULTANT should indicate the rate of Royalty considered in their offer.
- 40.0 BUSINESS SECRET/MARKETING DISCIPLINE :**
- 40.1** It is hereby specifically agreed by the successful tenderer that this clause shall be deemed to be a condition going to the root of this offer, that the successful tenderer shall not at any time during the subsistence of this contract or any time after its termination, call itself or hold out itself, advertise in any manner whatsoever by publication or otherwise, by printing, in writing or by any visual representation, either in its letter heads or news paper or magazines or leaflets, or by broadcasts over radio or by television or by any other media communication or In any manner whatsoever other than the appropriate Government Authorities to the extent necessary unless so permitted in writing by MRPL.
- 40.2** The successful tenderer hereby agrees and undertakes not to disclose to any party whatsoever any formulate blend order, specifications, trade secrets, marketing projection or intelligence or any other data or information and shall keep absolute secrecy in all matters pertaining to this offer, all correspondence relating thereto, all instructions given or anything having any relevance with the offer on any matter touching or arising out of this arrangement including the Books, Accounts, papers and correspondence and shall keep strictest secrecy and confidence thereto to any person whomsoever other than appropriate



Government Authorities to the extent necessary, unless directed to do so by MRPL in writing.

41.0 SEVERABILITY:

Should any provision of this agreement be found to be invalid, illegal or otherwise not enforceable by any court of law, such finding shall not affect the remaining provisions hereto and they shall remain binding on the parties hereto.

SECTION - V

42.0 PAYMENT TERMS :

(Payment terms mentioned in the Exhibit -9 supercedes the Payment term mentioned in the General Conditions of Contract).

42.1 Unless otherwise specified, 100% Payment will be made for the actual work done / supply of materials/Job/services performed and bills duly certified by Engineer In-charge (subject to submission of SD, if applicable). Such payment will be made within 15 days of submission of bills.

42.2 Retention money, if specified, will be withheld before releasing all payments i.e either monthly or progressive/ stage-wise payments.

42.3 Bills can be submitted after completion of work/ once on monthly basis against progressive work completion/as per milestones specified as per Tender.

42.4 PAYMENT MODE :

All payments shall be through electronic mode (RTGS/NEFT). Therefore, vendors are requested to furnish the information as per attached format on issue of order to successful bidder. Any change in the particulars shall be immediately informed to MRPL.

43.0 ADVANCE PAYMENT/MOBILISATION ADVANCE :

43.1 MRPL do not entertain Advance payment to the successful bidder.

43.2 In case, mobilization advance is insisted by any bidder, the same shall be decided on need basis only with Interest bearing. Such Advance will be made only after submission of bank guarantee for 110 % of advance amount.

43.3 The bank guarantee shall be submitted strictly as per the BG format enclosed with this tender document. No changes in Format will be allowed.

43.4 The advance payment will be released only after receipt of confirmation of BG directly from the BG Issuing bank. Such confirmation is accepted in the form of E-Mail from Bank directly, Direct Fax message, are through mails(Register/speed post/courier etc).

43.5 Interest charges shall be payable on the advance amount paid @ SBI lending rate prevailing at the time of release of payment plus 2 %.

43.6 Interest bearing advance payment shall be released in 2 or more installments/Stages as mutually agreed, based on progress of the work/Mobilization. The next/subsequent installment of such Advance shall be released only after submission of utilization certificate for the previous Advance installment made to the party.

43.7 Part BG's based on advance installments are also allowed.

43.8 The advance payment is recoverable proportionately from the progressive bills duly certified by the Engineer in Charge. Full Advance will be recovered against payments due on Mechanical completion of the work/completion of supply as applicable. Such recovery shall be time based, but not essentially linked with progress of work.

43.9 Interest free advance payment is not allowed for any cases.



SECTION - VI

44.0 ARBITRATION & CONCILIATION:

Refer Article-14 of form of contract

45.0 JURISDICTION:

- 45.1** Contract / Purchase Order, including all matters connected with this Contract / Purchase Order shall be governed by the Indian law both substantive and procedural, for the time being in force and shall be subject to the exclusive jurisdiction of Indian Courts at Mangalore.
- 45.2** Foreign companies, operating in India or entering into Joint ventures in India, shall have to obey the law of the land and there shall be no compromise or excuse for the ignorance of the Indian legal system in any way.

SECTION - VII

46.0 TAXES and DUTIES:

46.1 INDIAN TAXES / DUTIES

Goods and Services Tax (GST)

- 46.1.1** The quoted price shall be deemed to be inclusive of all taxes / duties / cess /levies / fees etc except "Goods and Services Tax" (hereinafter called GST) (i.e., IGST or CGST and SGST/UTGST as applicable in case of interstate supply or intra state supply respectively and GST compensation Cess if applicable), except as specifically provided to the contrary in the Special Conditions of Contract. GST (CGST/SGST/IGST) shall be as quoted by the bidder.
- 46.1.2** The quoted price shall be deemed to be inclusive of all taxes / duties / cess / levies / fees etc including GST as applicable and CONSULTANT only shall within their quoted price be liable to pay and bear any and all duties, taxes, levies, cesses etc. lawfully payable or liable to be payable on any goods, equipment or materials imported into India or procured within any local limits for incorporation in the work(s) at CONSULTANT 's end.
- 46.1.3** The CONSULTANT shall be liable for and shall pay any and all fees, cesses, taxes, duties, levies etc. assessable against CONSULTANT in respect of or pursuant to the Contract.
- 46.1.4** In addition, the CONSULTANT shall be responsible for payment of all duties, levies, and taxes assessable against the CONSULTANT or CONSULTANT 's employees or their Sub CONSULTANT s whether corporate or personal or applicable in respect of property.
- 46.1.5** Any errors of interpretation of applicability of all taxes / duties / cess / levies / fees etc by the CONSULTANT shall be to CONSULTANT 's account.
- 46.1.6 Goods and Services Tax (GST)**
GST is implemented by Government of India w.e.f 01.07.2017. "GST" shall mean Goods and Services Tax charged on the supply of Goods and Services. The term "GST" shall be construed to include the Integrated Goods and Services Tax (hereinafter referred to as "IGST") or Central Goods and Services Tax (hereinafter referred to as "CGST") or State Goods and Services Tax (hereinafter referred to as "SGST") / Union Territory Goods and Services Tax (hereinafter referred to as "UTGST") depending upon the import / interstate or intrastate supplies, as the case may be. It shall also mean GST compensation Cess.
- 46.1.7 Invoicing under Goods and Services Tax (GST) Rules:**
- i. CONSULTANT shall be required to issue tax invoice in accordance with GST and GST Rules, as applicable from time to time, so that input credit can be availed by Owner. In



ENGINEERING, PROCUREMENT AND CONSTRUCTION MANAGEMENT (EPCM) SERVICES FOR INSTALLATION OF LPG AMINE ABSORBER SYSTEM IN PFCC UNIT AT MRPL, MANGALURU

- the event that the CONSULTANT fails to provide the invoice in the form and manner prescribed under the GST Act read with GST Invoicing Rules there under, Owner shall not be liable to make any payment on account of GST against such invoice.
- ii. As per Section 17 (5) c) of CGST Act, the Owner will not get Input Tax credit for Works contract services when supplied for construction of an immovable property (other than plant and machinery).
 - iii. GST shall be paid against receipt of tax invoice. CONSULTANT / Vendor shall forthwith upload the appropriate document at GSTN portal complying with all GST regulations including but not limited to payment of GST by CONSULTANT / vendor. In case of non-receipt of tax invoice or non-payment of GST by the CONSULTANT, Owner shall withhold the payment of GST.
 - iv. GST payable under reverse charge for specified services or goods under GST act or rules, if any, shall not be paid to the CONSULTANT. If the same has already been reimbursed / paid to the CONSULTANT for any reason whatsoever, the said amount shall be deducted / recovered / adjusted from the payment due to the CONSULTANT.
 - v. Further, GST payment shall be limited to the amount worked out on the total executed and certified amount (on which GST is applicable) based on the contracted rates.
 - vi. The CONSULTANT shall mention their registration status (Registered / Composition / Unregistered) on the bill / invoice. In case there is change in the Registration status of the CONSULTANT during the execution of the contract the same should be advised immediately. Due to change in the Registration status. Owner will not be liable for any additional payments, whatsoever, including tax payments.
 - vii. The classification of goods/services as per GST Tariff should be correctly done by the CONSULTANT to ensure that input tax benefit is not lost to the OWNER on account of any error on the part of the CONSULTANT.
 - viii. The CONSULTANT shall comply with all the provisions of the GST Act /Rules / requirements like providing of tax invoices, payment of taxes to the authorities within the due dates, filing of returns within the due dates etc. to enable Owner to take Input Tax Credit (if applicable). The CONSULTANT shall always comply with the requirements of applicable laws and provide necessary documents as prescribed under the Rules & Regulations, as applicable from time to time. In particular, if any tax credit, refund or other benefit is denied or delayed to OWNER due to any non-compliance / delayed compliance by the CONSULTANT under the Goods & Service Tax Act (such as failure to upload the details of the sale on the GSTN portal, failure to pay GST) or due to non-furnishing or furnishing of incorrect or incomplete documents by the CONSULTANT, the CONSULTANT shall be liable to reimburse OWNER for all such losses and other consequences including, but not limited to the tax loss, interest and penalty. Notwithstanding anything contained anywhere in the Agreement, Owner shall be entitled to recover such amount from the CONSULTANT by way of adjustment from the invoice or from any other Securities like Bank Guarantees available to Owner. In addition to the amount of GST, OWNER shall also be entitled to recover interest at the rate prescribed under GST Act and penalty, in case any penalty is imposed by the tax authorities on Owner.
 - ix. Notwithstanding anything contained anywhere in the Agreement, in the event that the input tax credit of the GST charged by the CONSULTANT / Vendor is denied by the tax authorities to OWNER due to reasons attributable to CONSULTANT / Vendor. / OWNER shall be entitled to recover such amount from the CONSULTANT / Vendor by way of adjustment from the next invoice or from Bank Guarantee. In addition to the amount of GST, / OWNER shall also be entitled to recover interest and/or penalty, as the case may be, imposed by the tax authorities on / OWNER.



- x. Notwithstanding anything contained anywhere in the Agreement, any cost, liability, dues, penalty, fees, interest as the case may be, to which OWNER becomes liable, at any point of time on account of non-compliance of applicable tax laws or rules or regulations thereof or otherwise due to default on the part of CONSULTANT shall be borne by the CONSULTANT . Such cost, liability, dues, penalty, fees, and interest as the case may be shall be paid forthwith by the CONSULTANT and /or OWNER shall be entitled to recover such amount from the CONSULTANT by way of adjustment from the invoice or from any other Securities like Bank Guarantees available to OWNER. Any GST as may be applicable on such recovery of amount shall also be borne by CONSULTANT .”
- xi. TDS under GST, if applicable, shall be deducted from CONSULTANT 's bill at applicable rates. Certificate of the same would be available at GSTN portal as per GST Rules.
- xii. CONSULTANT shall raise their invoice in favour of OWNER with following details:
Mangalore Refinery and Petrochemicals Limited
Kuthethoor P.O., Via Katipalla
Mangalore – 575030.
GSTIN: 29AAACM5132A1ZZ
PAN: AAACM5132A

46.1.8 MRPL reserves the right to suspend / cancel / terminate the contract in the event of frequent / multiple / repeated defaults by the Vendor/Supplier/CONSULTANT in complying with the above requirements as per GST.

46.1.9 Payment to Vendor/Supplier/CONSULTANT shall be net of tax deduction / tax collection at source, if any, applicable as per laws / rules from time to time.

46.1.10 Any errors of interpretation of applicability of all taxes / duties / cess / levies / fees / charges etc. by the Bidder shall be to Bidder's account and shall be deemed to have been included in the quoted price.

46.1.11 NEW TAXES & DUTIES

All new taxes / duties / cess / levies / fees notified after the date of unpriced bid opening / submission of any subsequent price implication / revised prices, but within Time for Completion / extended Time for Completion (by Owner due to reason attributable to OWNER), shall be to Owner's account. These shall be reimbursed against documentary evidence. However, in case of delay attributable to CONSULTANT , any new taxes / duties / cess / levies / fees imposed after Time for contractual Completion, shall be to CONSULTANT 's account.

46.1.12 STATUTORY VARIATIONS

No variation on account of taxes / duties / cess / levies / fees, statutory or otherwise, shall be payable by OWNER to CONSULTANT except for the variation in GST.

Any Increase in GST after the contractual completion period (including extended Completion period by Owner due to reason attributable to OWNER) shall be to CONSULTANT 's account, however, any decrease shall be passed on.

Any variation in GST at the time of supply of services, for any reasons, other than statutory, including variations due to turnover, shall be borne by bidder and shall be deemed to have been included in the quoted price.

46.1.13 INCOME TAX

The CONSULTANT shall be exclusively responsible and liable for all Direct Taxes, including income tax, profession tax and wealth tax, whether payable in India or in any other jurisdiction.



The CONSULTANT shall be responsible for ensuring compliance with all provisions of the direct tax laws of India including, but not limited to, the filing of appropriate Returns and shall promptly provide all information required by the owner for discharging any of its responsibilities under such laws.

Tax shall be deducted at source by OWNER from all sums due to CONSULTANT in accordance with the provisions of the Income Tax Act, as in force at the relevant point of time.

OWNER shall issue a Tax deduction or withholding certificate to the CONSULTANT evidencing the Tax deducted or withheld and deposited by OWNER on payments made to the CONSULTANT.

46.1.14 FIRM PRICES

The quoted price shall remain firm and fixed and valid until completion of the contract and shall not be subject to escalation for any reason what so ever.

46.2 IMPORTS AND CUSTOMS DUTIES: --Deleted

46.2 GENERAL:

46.2.1 In case GST is quoted as not applicable on freight charges, and if they are applicable at the time of delivery due to any reasons other than statutory, the same will be borne by the Vendor/Supplier/Consultant.

46.2.2 The benefit of any Tax exemption, concessions, rebate or any other incentives available when the Vendor/Supplier/Consultant or its Sub Vendor/Supplier/Consultant are performing their obligations under the Purchase Order / Work order, shall be passed on to MRPL.

46.2.3 Recoveries, if any, by MRPL shall be with applicable GST thereon as per GST laws.

46.2.4 Any error of interpretation of applicability of taxes / duties / cess / levies / fees / charges etc. by the Vendor/Supplier/Consultant shall be to Vendor/Supplier/Consultant's account.

46.2.5 Bidder to ensure that the benefit of a reduction in the tax rate or the input tax credit availed by any registered taxable person has resulted in commensurate reduction in the price of goods/services supplied by such person. Vendor/Supplier/Consultant agrees unconditionally that any benefit arising either directly or indirectly out of implementation of GST is mandatorily passed on to MRPL. Failure on the part of bidder to ensure the same shall attract the provision of Anti Profiteering as notified by the Govt of India.

46.2.6 Wherever GST is indicated / mentioned in the contract/tender/RFQ, it will include GST Compensation cess levied under The Goods and Services Tax (Compensation to States) Act, 2017.

46.3 GENERAL:

46.3.1 In case GST is quoted as not applicable on freight charges, and if they are applicable at the time of delivery due to any reasons other than statutory, the same will be borne by the Vendor/Supplier/CONSULTANT.

46.3.2 The benefit of any Tax exemption, concessions, rebate or any other incentives available when the Vendor/Supplier/CONSULTANT or its Sub Vendor/Supplier/CONSULTANT are performing their obligations under the Purchase Order / Work order, shall be passed on to MRPL.

46.3.3 Recoveries, if any, by MRPL shall be with applicable GST thereon as per GST laws.

46.3.4 Any error of interpretation of applicability of taxes / duties / cess / levies / fees / charges etc. by the Vendor/Supplier/CONSULTANT shall be to Vendor/Supplier/CONSULTANT 's account.



- 46.3.5 The classification of goods as per GST laws should be correctly done by the Vendor/Supplier/CONSULTANT to ensure that Input Tax Credit benefit is not lost to MRPL on account of any error/omission on the part of the Vendor/Supplier/CONSULTANT .
- 46.3.6 Bidder to ensure that the benefit of a reduction in the tax rate or the input tax credit availed by any registered taxable person has resulted in commensurate reduction in the price of goods/services supplied by such person. Vendor/Supplier/CONSULTANT agrees unconditionally that any benefit arising either directly or indirectly out of implementation of GST is mandatorily passed on to MRPL. Failure on the part of bidder to ensure the same shall attract the provision of Anti Profiteering as notified by the Govt of India.
- 46.3.7 Wherever GST is indicated / mentioned in the contract/tender/RFQ, it will include GST Compensation cess levied under The Goods and Services Tax (Compensation to States) Act, 2017.

46.4 LOADING OF TAXES/DUTIES:

- 46.4.1 Taxes and duties will be loaded as quoted by the bidder. However, if a BIDDER states that taxes/duties are not applicable at present and will be charged as applicable at the time of delivery then his bid shall be loaded by the maximum rate of taxes/duties applicable at the time of evaluation of Bids.

47.0 CHANGE IN LAW :

- 47.1 In the event of introduction of any new legislation or any change or amendment or enforcement of any Act or Law, rules or regulations of Government of India or State Government(s) or Public Body which becomes effective after the date of submission of Price Bid or revised price bid, if any, for this CONTRACT and which results in increased cost of the works under the CONTRACT through increased liability of taxes, (other than personnel and Corporate taxes), duties, the CONSULTANT/VENDOR/SUPPLIER shall be indemnified for any such increased cost by the MRPL subject to the production of documentary proof to the satisfaction of the MRPL to the extent which directly is attributable to such introduction of new legislation or change or amendment as mentioned above and adjudication by the competent authority & the courts wherever levy of such taxes / duties are disputed by MRPL.

- 47.2 Similarly, in the event of introduction of new legislation or any change or amendment or enforcement of any Act or Law, rules or regulations of Government of India or State Government(s) or Public Body which becomes effective after the date of submission of Price Bid or revised price bid, if any, for this CONTRACT and which results in any decrease in the cost of the works through reduced liability of taxes, (other than personnel and Corporate taxes) duties, the CONSULTANT/VENDOR/SUPPLIER shall pass on the benefits of such reduced cost, taxes or duties to the MRPL, to the extent which is directly attributable to such introduction of new legislation or change or amendment as mentioned above.

- 47.3 All duties, taxes (except where otherwise expressly provided in the Contract) as may be levied / imposed in consequences of execution of the Works/Services or in relation thereto or in connection therewith as per the Acts, Laws, Rules, Regulations in force on the date of submission of Price Bid or revised price bid, if any, for this CONTRACT shall be to CONSULTANT/VENDOR/SUPPLIER's account. Any increase / decrease in the net amount of such duties, taxes (i.e. the amount of taxes/duties payable minus eligible credit of taxes / duties paid on input services / input) after the date of submission of price bid or revised price bid, if any, but within the contractual completion period / mobilization date as stipulated in the CONTRACT will be to the account of MRPL.

- 47.4 Any increase in net amount of the duties and taxes (i.e. the amount of taxes/duties payable minus eligible credit of taxes / duties paid on input services / inputs) after the contractual completion / mobilization date during the extended period will be to the Consultant 's account, where delay in completion /mobilization period is attributable to the CONSULTANT/VENDOR/SUPPLIER . However, any decrease in net amount of the duties



and taxes (i.e. the amount of taxes/duties payable minus eligible credit of taxes / duties paid on input services / inputs) after the contractual completion / mobilization date will be to MRPL's account.

- 47.5** The Contract Price and other prices given in the Schedule of Prices are based on the applicable tariff as indicated by the CONSULTANT/VENDOR/SUPPLIER in the Schedule of Prices. In case this information subsequently proves to be wrong, incorrect or misleading, MRPL will have no liability to reimburse/pay to the CONSULTANT/VENDOR/SUPPLIER the excess duties, taxes, fees, if any finally levied / imposed by the concerned authorities. However, in such an event, MRPL will have the right to recover the difference in case the rate of duty/tax finally assessed is on the lower side.
- 47.6** Notwithstanding the provision contained in clause 47.1 to 47.5 above, the MRPL shall not bear any liability in respect of :
- (i) Personal taxes on the personnel deployed by CONSULTANT/VENDOR/SUPPLIER, his sub-consultant / sub-sub Consultant s and Agents etc.
 - (ii) Corporate taxes and Fringe benefit tax in respect of CONSULTANT/VENDOR/SUPPLIER and all of their sub-Consultant s, agents etc.
 - (iii) Other taxes & duties including Customs Duty, Excise Duty and GST in addition to new taxes etc. in respect of sub-Consultant s, vendors, agents etc. of the CONSULTANT/VENDOR/SUPPLIER .

In order to ascertain the net impact of the revisions / enactment of various provisions of taxes / duties, the CONSULTANT/VENDOR/SUPPLIER is liable to provide following disclosure to MRPL

- (i) Details of each of the input services used in relation to providing service to MRPL including estimated monthly value of input service and GST amount.
- (ii) Details of Inputs (material/consumable) used/required for providing service to MRPL including estimated monthly value of input and excise duty/CVD paid/payable on purchase of inputs.

SECTION - VIII

48.0 MANPOWER EMPLOYED BY TENDERER :

- 48.1** The successful tenderer shall deploy adequate staff of the requisite competence that may be required for meeting the scope of services/work called for. It is hereby specifically agreed that the responsibility for the employment of staff and their salary, wages remuneration, etc, shall be the sole responsibility of the successful tenderer and that MRPL shall not be responsible in any manner directly or indirectly for such employment or expenses so incurred by successful tenderer thereof. Successful tenderer shall give a declaration to this effect. The CONSULTANT has to comply with all Labour related laws/rules in force w.r.t Minimum wages Act, Factories Act, Labour ACT and all other such regulations/amendments made from time to time and in force and maintain all documents as required by Law enforcing Authorities and produce the same as and when called for.
- 48.2** It is understood and agreed that there is no Employer- Employee relationship between MRPL and the CONSULTANT AND /or CONSULTANT 's employees in any way whatsoever and the CONSULTANT shall be the 'Employer' within the meaning of different Labour legislations in respect of workmen employed by the CONSULTANT . The CONSULTANT has to carry on their business or occupation as Independent CONSULTANT s and this point shall be made clear in writing to all persons engaged by the CONSULTANT before engagement of the person(s). The CONSULTANT shall issue an Employment card in Form XIV as per Contract Labour Regulation and Abolition Act 1970 OR Photo Identity card to each Worker.



49.0 MEDICAL: (if applicable)

49.1 In case of Annual Contracts exceeding more than one year, the CONSULTANT should get medical examination of the contract workers done every year either in MRPL Hospital or in ESI Hospital and produce the medical certificate in the prescribed format (Form No.16).

50.0 LABOUR LAWS :

50.1 The CONSULTANT shall obtain necessary licence from the Licensing Authority under the Contract Labour (Regulation & Abolition) Act, 1970 and the Central Rules framed there under and produce the same to the Engineer-in-charge before start of work.

50.2 The CONSULTANT shall not undertake or execute or permit any other agency or sub-CONSULTANT to undertake or execute any work on the CONSULTANT 's behalf through contract labour except under and in accordance with the licence issued in that behalf by the Licensing Officer or other authority prescribed under the Factories Act or the Contract labour (Regulation & Abolition) Act- 1970 or their applicable law rule or regulation if applicable.

50.3 The provision of EPF & MP Act. 1952 and the Rules/Scheme thereunder shall be applicable to the CONSULTANT and the employees engaged by him for the work. The CONSULTANT shall furnish the code number allotted by the RPFC Authority, to the Engineer-in-Charge before commencing the work.

50.4 The CONSULTANT shall be exclusively responsible for any delay in commencing the work on account of delay in obtaining a license under clause 6.1 above or in obtaining the code number under Clause 6.3 above and the same shall not constitute a ground for extension of time for any purpose.

50.5 The CONSULTANT shall enforce the provisions of ESI Act and Scheme framed thereunder with regard to all his employees involved in the performance of the Contract and shall deduct employee's contribution from the wages of each of the employees and shall deposit the same together with employer's contribution of such total wages payable to the employees in the appropriate account.

51.0 LABOUR RELATIONS :

51.1 In case of labour unrest/labour dispute arising out of non-implementation of any law, the responsibility shall solely lie with the CONSULTANT and he shall remove/resolve the same satisfactorily at his cost and risk.

51.2 The CONSULTANT shall deploy only duly qualified and competent personnel for carrying out the various jobs as assigned by the Engineer-in-Charge from time to time. The workmen deployment by the CONSULTANT should also possess the necessary licence etc., if required under any law, rules and regulations.

51.3 The CONSULTANT shall ensure that local labour, skilled and/or unskilled, to the extent available shall be employed in this work. Special preference shall be given to persons and/or dependents of persons whose land has been acquired for the project work. In case of non-availability of suitable labour in any category out of the above persons, labour from outside may employed.

51.4 The CONSULTANT shall not recruit personnel of any category from among those who are already employed by the other agencies working at site but shall make maximum use of local labour available.

51.5 Payment to contract workmen: In case of manpower based Contracts, CONSULTANT shall be responsible to make payment to his workers/ employees in respect of their salaries/ wages through bank cheques/ crediting to bank A/c; the consent of the labour should be obtained before crediting wages to the bank account, the CONSULTANT shall pay wages to all his employees on or before 7th of the following month under the supervision of authorised MRPL personnel and a copy of proof of payments to be



submitted to MRPL; MRPL may demand such payment of wages under supervision of MRPL, if found necessary. The rates of wages shall be in conformity to the minimum wages act.

52.0 CONSULTANT 'S LABOURERS TO LEAVE SITE ON COMPLETION OF THE WORK :

52.1 The CONSULTANT 's labourers must leave the location of the project site/township after the work is tapered/ completed to avoid creation of a Slum in the areas adjoining the project/township.

53.0 TEMPORARY WORKS :

53.1 All Temporary and ancillary works including enabling works connected with the work shall be responsibility of the CONSULTANT and the price quoted by them for erection shall be deemed to have included the cost of such works, which shall be removed by the CONSULTANT at his cost, immediately after completion of his work.

54.0 PROVIDENT FUND :

54.1 The CONSULTANT should strictly comply with the provision of the Employees Provident Fund Act.

a) Obtained licence under Contract Labour (Abolition and Regulation) Act 1970

b) P.F. Registration Number allotted to them by RPF.

c) The agencies should promptly deposit P.F. deduction of the eligible contract employees plus the employers contribution to the RPF. For this purpose agency must submit a certificate in their Bill that PF amount has been deducted from the eligible employees and along with the employers contribution has been deposited with RPF. In support of this the agency must furnish the challan / receipt for the payment made to RPF for the earlier months

54.2 **If the certificate and the challan / receipt are not furnished, the Finance & Accounts Dept. of Owner reserve the right to deduct 16% of the Running Account bill amount in case of Man power based contract and 5% of the Running Account bill amount in case of Composite / LSTK Orders. Deducted amount will be refunded to the CONSULTANT only on submission of Challan / receipt.**

55.0 OBSERVATION OF FORMALITIES RELATING TO PF, ESI, REGISTRATIONS :

55.1 It should be confirmed by the successful tenderer that his/their organisation is already registered with the Provident Fund Commissioner and the details may please be furnished to us for MRPL'S records and the reference. MRPL will reserve its right to inspect the records pertaining to Provident Fund rules (Annexure V).

55.2 PF / ESI Code: The Tenderer shall indicate his / their PF Code / ESI Number in their tender.

55.3 Income Tax: The Tenderer shall in all cases indicate his income tax Permanent Account Number. (PAN). Income Tax Permanent Account Number will be required as precondition of release of payment.

Note: The bidder will have to bear all Income Tax Liabilities both corporate & personal tax. Income Tax along with surcharge of Income Tax as applicable at the prevailing rate on the gross amount billed shall be deducted from the CONSULTANT 's bill as per applicable laws.

56.0 INSURANCE :

Refer Article 9 of Form of Contract

57.0 CONSULTANT FURNISHED INSURANCE:

Refer Article 9 of Form of Contract



58.0 VERIFICATION OF CHARACTER AND ANTECEDENTS OF CONTRACTUAL MANPOWER:

In all contracts involving deployment of CONSULTANT 's manpower within MRPL premises like Plants and Offices etc. the CONSULTANT shall submit the following documents to MRPL prior to start of work:

- 58.1** Undertaking from the CONSULTANT that they have scrutinised the previous work history of the person(s) proposed to be deployed by them and character and antecedents of person(s) proposed to be deployed by them is / are impeccable.
- 58.2** Along with the above mentioned undertakings, the CONSULTANT will provide certified photocopies of police verification certificate for inspection by the authorised representatives of MRPL. The CONSULTANT has to obtain Police Verification Report from the area where the person(s) to be deployed has / have been residing since the last five years. In case the person concerned has not resided at a place for five years at a stretch, Police verification reports should be obtained from that area where the person(s) has / have stayed earlier.
- 58.3** The CONSULTANT shall ensure at the time of submitting their final bills to the EIC, that it is accompanied by a NOC from Security Dept., MRPL, for having surrendered all Photo passes and Bio-Metric cards issued by MRPL. If any Pass and Bio-Metric Cards are not surrendered even after the completion of job / contract, the CONSULTANT s are liable to pay a fine of Rs.200/- for every un-surrendered pass and Rs. 100/- for every Bio-Metric card (These fine amounts are subject to revision by Security Dept., MRPL, from time to time.

59.0 BROAD GUIDELINES FOR EFFECTIVE IMPLEMENTATION OF CONTRACT MANAGEMENT SYSTEM AND MEETING OF STATUTORY REQUIREMENTS IN ENGAGEMENT OF SECONDARY WORK FORCE:

A. Whenever a work order is issued following documents are required to be submitted to HR Department by CONSULTANT duly signed by Engineer In Charge:

I. Where Labour engaged by the CONSULTANT s is less than 19:

1. Copy of the Valid Work Order / LOA Copy.
2. Work Commencement letter by the CONSULTANT in Form 6A / Notice of Commencement
3. Register of Workmen in Form No. XIII
4. Copy of the PF code allotted by the Competent Authority.
5. Copy of the ESI code allotted by the Competent Authority.
6. Workmen's compensation policy.
7. Age proof, Aadhar card number and Bank Account details of the worker.

II. Where Labour engaged by the CONSULTANT s is more than 19:

1. Copy of the Valid Work Order / LOA Copy.
2. Work Commencement letter by the CONSULTANT in Form 6A / Notice of Commencement
3. Register of Workmen in Form No. XIII
4. Copy of the PF code allotted by the Competent Authority.
5. Copy of the ESI code allotted by the Competent Authority.
6. Request letter from the CONSULTANT for issuance of Form No.V for apply labour license through EIC.
7. Submission of Form No. IV for proof of applying labour license attested by the ALC.
8. Interstate migrant license copy if labour engaged more than five from other states.
9. Workmen's compensation policy.
10. Age proof, Aadhar card number and Bank Account details of the worker.



III. Documents required on monthly basis duly certified by Engineer In charge:

1. Wage register duly certified by the Engineer Incharge
2. Attendance Register duly certified by the Engineer Incharge
3. Payment of wages should be disbursed within 7 days from the close of wages period.
4. ESI / PF Challans receipt along with PF-ECR Copy & Monthly contribution details for payment to Statutory Authorities in respect of the wages paid for the previous month with covering letter.
5. Bank statement for wages paid
6. Insurance copy for those who are not covered under ESI Act.
7. Form No. 5 & 10 and Male and Female data for each month.

B. Documents required on annual basis for release of bank Guarantee / security deposit duly certified by the Engineer Incharge.

1. Work Completion letter by the CONSULTANT in Form 6A/ Notice of completion.
2. Annual medical check-up data.
3. Payment of bonus as per statute.
4. Payment of leave with wages @ 1 days for the every 20 days worked by workers.
5. Payment of gratuity if applicable (on completion of 5 years of continuous service).
6. NOC from Security Dept. On Surrendering of punch card and entry pass issued by MRPL.
7. Register of over time. Form no. XXIII.
8. Wage slip in form no. XIX.
9. Register of damages or loss form no XX.
10. Register of fine. Form no. XXI.
11. Register of advance. Form no. XXII
12. Employment card XIV.
13. Indemnity bond.
14. Half yearly / Yearly labour return in form XXIV(sec rule 82(1) to the licensing officer under contract labour returns.
15. Half yearly return in form 5A (regulation 26) on ESI contribution.

C. PROCEDURE ADOPTED BY HR IN DEALING WITH CONSULTANT S

- CONSULTANT shall submit the documents as specified above with a cover note signed through EIC to HR department.
- On submission of compliance report / recommendations from EIC, HR will give clearance to Finance for release of payment.
- Any deviation from the above procedure and non-production of required documents will result in delay in issuance of gate pass and payment of monthly bill, final bill and release of retention money / Security Deposit / Bank Guarantee, etc.
- CONSULTANT should also give an indemnity bond to MRPL absolving MRPL of all statutory, Non-statutory clearance by their employees, sub-CONSULTANT s and supplies.



60.0 DETAILS OF MINIMUM PAYMENT TO WORKFORCE EMPLOYED BY CONSULTANT

The CONSULTANT shall pay Minimum as per the following table to the workforce deployed by him under various categories(Unskilled / Semiskilled / Skilled / Highly Skilled) as applicable

Sl no	Description	Payment basis			
1	Basic Wages per day	As per Minimum wages act issued from time to time by ALC			
2	PF/Admin charges	13 % of Basic Wages & MRPL Special Allowance			
3	ESI	3.25 % of Basic Wages, MRPL Special Allowance & Shift allowance (if applicable).			
4	Leave Wages	5 % of Basic Wages (As per ALC)			
5	Bonus	8.33 % of min wages or Rs 7000 /- per annum whichever is higher			
6	Holiday wages	10 days per year			
7	MRPL Special Allowance per day	Unskilled(in Rs)	Semi Skilled (in Rs)	Skilled (in Rs)	Highly skilled (in Rs)
		34	50	70	90

Note: Please refer details of the Minimum wages as mentioned in the SCC/Scope of Work (as applicable).

The following to be complied:

- Shift allowance (if applicable) – Shift allowance @ Rs 25 /- per shift to be provided to Secondary work force coming in rotational shift (i.e., morning, evening and night shifts) working in plant area.
- Annual Medical Check-up for Workforce to be complied by the CONSULTANT .
- PF/ESI remittance to be ensured on MRPL Special Allowance.
- Rates of MRPL special allowance shall be Rs 34, Rs 50, Rs 70 & Rs 90 for Unskilled, Semi-Skilled, Skilled & Highly Skilled Category respectively.
- Gratuity to be paid as per the statutory norms based on the government directives.
- Number of closed Holidays shall be 10 days per year.
- Extended working hours shall be compensated suitably as per statutory provisions.
- Group term life Insurance cover to be taken having a risk coverage 24 X 7 death coverage(Natural /Accidental death) with a sum assured of Rs.10,00,000/-(Rs.Ten lacs only).
- Statutory provisions if in contradiction will prevail over any Special conditions of the Contract.
- Transportation facility in respect of Secondary Workforce for commuting to entry gates of MRPL shall be in the scope of the CONSULTANT . However, for internal transport from entry gate to place of work; existing circular vehicles to be utilised.
- For ensuring compliance to the above, suitable number of welfare officers to be placed by CONSULTANT s with respect to all statutory provisions.
- Uniform/ Boiler suit-2 sets per year, Helmet, Shoes, Raincoat to be provided to the workforce and proof to be submitted.



SECTION - IX

61.0 STATUTORY REQUIREMENTS/ SAFETY RELATED ASPECTS :

(Please refer Safety Policy Annexure II to SCC of Exhibit-2).

- a) This shall be read in conjunction with the MRPL General Conditions of Contract, Special Safety Precautions to be taken by the CONSULTANT s working in Operating Refinery, Specification of Work, Drawing or any other document forming part of this contract wherever the context so requires.
- b) CONSULTANT shall be responsible for the safety and health of all his employees.
- c) All Liabilities under IE rules 1956/labour laws, insurance on account of this contract for personnel/labour shall be done by the CONSULTANT . Engineer In-charge in co-ordination with P&A dept will be ensuring that all these statutory requirements pertaining to labour and safety is complied by the CONSULTANT during the execution of the said contract. Workmen employed by the CONSULTANT are required to comply with/maintain the following under contract labour (regulation and abolition) act and also make it available for the inspection by GM (P &A).
 - Workmen register
 - Attendance register
 - Wage register (payment to be made strictly as per minimum wages act)
 - Work commencement certificate from labour commissioner and labour license if required
 - Insurance cover towards temporary disablement and permanent disablement for the workmen
 - PF Contribution -As per PF act the CONSULTANT has to obtain separate code for the PF of their employee from the PF commissioner/MRPL. Details of payment of PF for the wages disbursed by the CONSULTANT to the workmen shall be submitted to GM (P & A) periodically.
- d) The CONSULTANT should give an Undertaking that he has gone through all terms and conditions of MRPL General Conditions of Contract and all terms and conditions are agreeable to them.
- e) CONSULTANT shall ensure strictly all Safety Precautions to be taken in an Operating Refinery. Special safety precautions to be taken by the CONSULTANT s working in operating refinery is to be taken from Engineer In-charge.
- f) CONSULTANT shall ensure that all workmen entering refinery premises are provided with valid photo gate passes and to be produced on demand by each workman.
- g) The CONSULTANT shall submit the Bio-data of all the employees including the Supervisor to the Engineer-in-charge before taking up the job. Only those employees whose Bio-data are approved shall be allowed to work inside the Refinery Complex. The personnel engaged by the CONSULTANT shall maintain good conduct and discipline commensurate with Industrial standard. If in the opinion of the Engineer-in-charge any of the personnel have not maintained good conduct and discipline, the CONSULTANT shall remove such personnel immediately from MRPL premises and provide alternate personnel.
- h) The CONSULTANT shall make his own transport arrangements/stay and food for their personnel during normal duties as well as extended duties and no company transport shall be provided to the CONSULTANT .
- i) The CONSULTANT shall make himself fully conversant with the locations and the type of job to be carried out.



- j) House keeping of the workplace shall be done strictly by the CONSULTANT on daily basis or as required by the Engineer-in-charge. CONSULTANT to collect all debris/ scrap and dump at designated Scrap Yard within the Refinery.
- k) The CONSULTANT shall prepare plan for executions of jobs and get the same approved by the Engineer-in-charge. The CONSULTANT shall submit progress report at specified intervals and shall be responsible to ensure the specified progress.
- l) The CONSULTANT shall ensure that day's work planned by MRPL Engineer-in-charge is completed on the same day. In case of backlog, the CONSULTANT to increase the manpower or equipment resources to ensure timely completion of the job.
- m) The CONSULTANT shall ensure good workman-ship in all the jobs carried out. Any defects found in the completed jobs shall be rectified by the CONSULTANT free of charge to the satisfaction of the Engineer-in-charge.
- n) If at any stage of the work, the progress of the Job is found unsatisfactory, MRPL reserves the right to carry out the remaining portion of the Job by hiring the services of the other agencies and charge the cost of such services to CONSULTANT 's account. In case of any disputes MRPL's decision will be final & binding.
- o) The work to be carried out in a manner so as not to cause damage to the surroundings. Damage if caused during carrying out the Job has to be made good by the CONSULTANT at no extra cost to MRPL.
- p) No Extra Bill or Claim for extra work or supply of material will be entertained unless undertaking of such extra work/supply of material has been authorised by MRPL in writing.
- q) MRPL reserves the right to terminate the Contract without assigning any reason at any time during the validity of the Contract period.
- r) Bills shall be submitted to Accounts Dept. on any working day duly certified by the Engineer-in-charge after completion of work.
- s) MRPL reserves the right to award the job in full or in any combination of the items as felt convenient.

SECTION - X

62.0 GENERAL GUIDELINES TO SUPPLIERS (AS APPLICABLE) FOR ENVIRONMENT AND ENERGY COMPATIBILITY

MRPL is an organization which is certified to ISO 14001 Environment Management System and ISO 50001 Energy Management System and looks forward to its service providers to help them maintain the system that is designed for this purpose.

All suppliers are to ensure compliance to the following while they are providing Materials to MRPL or providing services within the premises of MRPL .

- a) Ensure that the products supplied are Eco friendly (easily disposable as bio-degradable waste and the end of life or with a buy back condition), when not covered by PO specification.
- b) Products supplied should be non-polluting when in operation/service.
- c) Items supplied are to be energy efficient i.e. "Star rated".
- d) Ensure that the packing and Packaging material used are disposal as bio-degradable waste or with buy back condition.
- e) Material Safety Data Sheets contain environment /energy related data /information on energy efficiency usage, storage, spillage and easy disposal.
- f) Specify action to be taken for spillages, if any to prevent contamination of air, land and water.
- g) Ensure that there is no threat to environment during transportation to and returns from MRPL, during delivery / while supplying materials.



- h) Material supplied should not lead to damage or harm to vegetation and greenery while usage and disposal.
- i) Supplier shall comply with all applicable regulations regarding the supplied Goods including all materials used and shall provide all information necessary by such regulation and/or requested by MRPL
- j) Supplier shall be responsible, where physically possible, to take the Goods back for the purpose of recycling them within the scope of the statutory requirements or to dispose them in an environmentally-friendly manner.
- k) Suppliers are to take action and comply with requirements when failures are intimated by MRPL and repeated failures /failure to act may lead to termination of contracts.
- l) Ensure that the noise and pollution levels of vehicles and equipment when used to deliver goods are as per regulatory norms and are subject to verification.

63.0 GENERAL GUIDELINES TO SERVICE PROVIDERS (AS APPLICABLE) FOR ENVIRONMENT AND ENERGY COMPATIBILITY

MRPL is an organization which is certified to ISO 14001 Environment Management System and ISO 50001 Energy Management System and looks forward to its service providers to help them maintain the system that is designed for this purpose.

All service providers are to ensure compliance to the following while they are providing Materials to MRPL or providing services within the premises of MRPL.

- a) Ensure that the products used while providing service are Eco friendly (easily disposable as bio-degradable waste and the end of life or with a buy back condition), when not covered by PO specification
- b) Activities of the service provider should be non-polluting either by design or through control.
- c) Equipment's brought for providing service are energy efficient i.e. star rated
- d) Ensure that the packing and Packaging material brought are disposal as bio-degradable waste or with buy back condition.
- e) Material Safety Data Sheets are available for material brought for providing service and contain environment /energy related data / information on energy efficiency usage, storage, spillage and easy disposal.
- f) Follow action specified by MRPL to be taken for spillages, if any to prevent contamination of air, land and water.
- g) Ensure that there are no threats to environment during transportation of material to and returns from MRPL to be used for providing service to MRPL.
- h) Material brought for usage and disposed at MRPL, should not lead to damage or harm to vegetation and greenery.
- i) Supplier shall comply with all applicable regulations regarding the materials used and shall provide all information necessary by such regulation and/or requested by MRPL
- j) Supplier shall be responsible, where physically possible; to take the Goods back for the purpose of recycling them within the scope of the statutory requirements or to dispose them in an environmentally-friendly manner, when covered by contract.
- k) Suppliers are to take action and comply with requirements when failures are intimated by MRPL and repeated failures /failure to act may lead to termination of contracts.
- l) Ensure that the noise and pollution levels of vehicles and equipment used for providing service within MRPL are as per regulatory norms and are subject to verification
- m) Segregate waste generated when providing service as per the scope of work as per MRPL norms i.e. Metal, Bio-degradable, Non-biodegradable, Solid waste and Hazardous waste,.
- n) Dispose waste generated as per MRPL norms in the appropriate waste bins provided.



- o) Prevent / minimize /control /contain pollution by control on emission of gases, spillages when providing service as per the scope of work
- p) Supplier shall be responsible, where physically possible, to take its Goods back for the purpose of recycling them within the scope of the statutory duties or to dispose of them in an environmentally-friendly manner.
- q) Follow safety precautions as per MRPL norms, when providing service as per the scope of work.
- r) Prevent wastage, excessive consumption and misuse of Electricity, steam and water.

SECTION – XI

64.0 (MSEs & STARTUP COMPANIES)

CONDITIONS FOR MICRO AND SMALL ENTERPRISES (MSEs)

- 1) As per Public Procurement policy (PPP) for Micro & Small Enterprises (MSEs) Order, 2012 issued vide Gazette Notification dated 23.03.2012 by Ministry of Micro, Small and Medium Enterprises of Govt. of India, MSEs must be registered with any of the following in order to avail the benefits / preference available vide Public Procurement Policy MSEs Order, 2012.
 - a) District Industries Centers (DIC)
 - b) Khadi and Village Industries Commission (KVIC)
 - c) Khadi and Village Industries Board
 - d) Coir Board
 - e) National Small Industries Corporation (NSIC)
 - f) Directorate of Handicraft and Handloom
 - g) Any other body specified by Ministry of MSME (MoMSME)
 - h) Udyog Aadhaar Acknowledgment / Udyog Aadhaar Memorandum issued by MoMSME.
 - i) Udyam Registration Portal

MSEs participating in the tenders must submit valid & authorized copy of certificate of registration with any one of the above agencies. In case of bidders submitting DIC registration certificate, he shall attach original notarized copy of the DIC certificate.

- 2) The MSEs registered with above mentioned agencies /bodies are exempted from payment of Earnest Money Deposit (EMD).
- 3) The definition for Micro & Small Enterprise shall be as per the guidelines issued by Ministry of MSME vide Gazette notification no. 1702(E) dated 01.06.2020 and 2119(E) dated 26.06.2020 which came into effect from 01.07.2020.
- 4) To be classified as Micro or Small Enterprises as per new definition, The companies need to register themselves on “Udyam Registration Portal” on or after 01.07.2020. This provision is for new establishments as well as for existing MSE companies registered with NSIC, UAM etc.
- 5) The existing MSE companies registered prior to 30.06.2020 shall continue to be valid only for a period up to 31.03.2021.
- 6) Bidder shall be Manufacturer for supply items
As per the MoMSME, the benefits of the PP Policy extended only to manufacturers registered under this and are not applicable to traders/ dealers/resellers/ distributors/authorized agents etc. Accordingly, the eligible MSE bidders shall be registered for the item tendered.



Bidder shall submit proof that he is a manufacturer of the item for which he is quoting and he shall highlight the details of his manufacturing status in the MSE certificate against the item he is proposing to bid in the tender. However, in cases where installation / commissioning and related activities along with Purchase of item(s) is/are involved and the bidder has relevant MSE certification, then he shall be eligible for claiming benefits of the PP Policy.

- 7) The registration certificate issued must be valid as on Bid closing date of the tender. Bidder shall ensure validity of registration certificate in case bid closing date is extended.
- 8) The MSEs who have applied for registration or renewal of registration with any of the above agencies/bodies, but have not obtained the valid certificate as on close date of the tender, are not eligible to avail benefits under PP Policy. Where validity of such certificates such as NSIC certificate has lapsed, it shall be the responsibility of the bidder to seek renewal from the concerned Govt agency before such expiry. Documentary evidence seeking extension before the lapse of validity of such certificate and an authorization letter from the Govt agency having received application for renewal shall be submitted before the bid closing date.
- 9) MRPL being a critical refinery installation, vital to public safety and maintaining essential supplies to the society and other customers including Govt agencies, reserves right to grant relaxation in tender conditions under the Public Procurement Policy on procurement of goods and services from Micro and Small Enterprises (MSEs) order 2012/other Government guidelines as applicable from time to time.

10) Purchase Preference:

- a) Items which are reserved for exclusive purchase from Micro and Small Enterprises shall be procured from Micro and Small Enterprises as per Public Procurement Policy.
- b) Subject to meeting terms and conditions stated in the tender document, **twenty five** percent of the total quantity of the tender is earmarked for MSEs registered with above mentioned agencies/bodies for the tendered item/services.
- c) In case MSE bidder is L1 entire value of the tender is to be ordered on the L1 MSE bidder.
- d) In tender, participating Micro and Small Enterprises quoting price within price band of L1 + 15% shall also be allowed to supply a portion of requirement by bringing down their price to L1 price in a situation where L1 price is from someone other than a Micro and Small Enterprise and such Micro and Small Enterprise shall be allowed to supply upto **25 percent** of the total tendered value (where the tender quantity can be split).
- e) In case of more than one such MSEs are in the price band of L1 + 15% and matches the L1 price, the supply may be shared proportionately if the job can be split.
- f) In case the tendered quantity cannot be split, MSE shall be allowed to supply total tendered quantity provided their quoted price is within a price band of L1 + 15 percent and they match the L1 price.
- g) If the quantity cannot be split and there are more than one eligible MSE bidders (price band within L1+15%) then the opportunity to match the L1 rate of the tender shall be given first to MSE (who have quoted lowest rate among the MSEs within the price band of L1+15%) and the total quantity shall be awarded to him after matching the L1 price of the tender.



ENGINEERING, PROCUREMENT AND CONSTRUCTION MANAGEMENT (EPCM) SERVICES FOR INSTALLATION OF LPG AMINE ABSORBER SYSTEM IN PFCC UNIT AT MRPL, MANGALURU

h) If the MSE who have quoted lowest rate among the MSEs in the price band of L1 + 15% do not agree to match the rate of L1 of the tender, then the next ranked MSE bidder who has quoted within the price band of L1 + 15% in order shall be given chance to match the rate of L1 for award of the quantity/order.

i) For more clarity in this regard, following table is furnished;

Type of Tender	Price quoted by MSE	Finalization of tender
Can be Split	L1	Full order on MSE
Can be Split	Not L1 but within L1+15%	25% order on MSE subject to matching L1 price
Cannot be Split	L1	Full Order on MSE
Cannot be Split	Not L1 but within L1+15%	Full Order on MSE subject to matching L1 price

j) In case where the tender quantity can be split and MSE vendor is already getting order for more than 25% of the tendered quantity / value, no additional purchase preference is required to be given in the tender.

k) In case MSE vendor is already getting order less than 25% of the tendered quantity / value, purchase preference to this and other vendors (together) shall be given only up to the differential quantity to make total as 25% to MSE vendor.

l) In case where quantity against a line item cannot be split (i.e., minimum 25% to MSEs) or items with single quantity or in grouped item, the complete line item/group shall be awarded on MSE bidder within the price range of L1 bidder's evaluated price + 15% subject to their matching L1 bidder's price.

m) The purchase preference to MSE is not applicable for works contracts where supply of goods not produced by MSEs is also involved.

11) Out of the **twenty five** percent target of annual procurement from micro and small enterprises **four percent** shall be earmarked for procurement from micro and small enterprises owner by Scheduled Caste & Scheduled Tribe entrepreneurs. In the event of failure of such MSEs to participate in the tender process or meet the tender requirements and L1 price five percent sub-target so earmarked shall be met from other MSEs.

12) Special provision for Micro and Small Enterprise owned by women. Out of the total annual procurement from Micro and Small Enterprises (MSEs), 3% from within the 25% target shall be earmarked for procurement from MSEs owned by women.

13) To qualify for entitlement as SC/ST owned MSE, the SC/ST certificate issued by District Authority in addition to certificate of registration with any one of the agencies mentioned in paragraph (1) above. Alternatively, the bidder shall be responsible to furnish necessary documentary evidence for enabling MRPL to ascertain that the MSE is owned by SC/ST/Women entrepreneurs. MSE owned by SC/ST/Women is defined as:

- In case of proprietary MSE, proprietor(s) shall be SC/ST/Women
- In case of partnership MSE, The SC/ST/Women partners shall be holding at least 51% shares in the enterprise.



ENGINEERING, PROCUREMENT AND CONSTRUCTION MANAGEMENT (EPCM) SERVICES FOR INSTALLATION OF LPG AMINE ABSORBER SYSTEM IN PFCC UNIT AT MRPL, MANGALURU

c) In case of Private Limited Companies, at least 51% share shall be held by SC/ST/Women promoters.

14) If the bidder does not provide appropriate document or any evidence to substantiate the above, then it will be presumed that he does not qualify for any preference admissible under the Public Procurement Policy, 2012.

15) **TReDS:** TReDS is an electronic institutional mechanism for facilitating the financing of trade receivables of MSMEs through multiple financiers. MRPL is already registered on the following TReDS platform:

- M/s Receivable Exchange of India (RXIL), Mumbai,
- M/s Mynd Solutions Private Limited (Mynd), New Delhi
- M/s A TREDIS (Invoicemart), Mumbai

MSE vendors are required to register on the TReDS platform. The MSME vendors can avail the TReDS facility, if they want to.

Declaration Form for availing purchase preference

Sr.no	Paramter	Declaration	Remarks
1	Whether bidder is an MSE bidder?	Yes/ No	If Yes – Necessary documents to be attached with unpriced part of the bid
2	Whether bidder wants avail purchase preference under Public Procurement Policy-2012 ?(PPP-2012)	Yes/ No	If Yes- Bidder will not be entitled for Purchase Preference Linked with Local Content-2017. (PP-LC 2017)
3	Whether bidder wants avail Purchase Preference Linked with Local Content-2017? (PP-LC 2017)	Yes/ No	If Yes- 1. Bidder will not be entitled for purchase preference under Public procurement Policy 2012? (PPP-2012) 2. Bidder shall furnish the percentage of Local content with declaration that the percentage of Local content is calculated as per the calculation methodology given herewith. 3. The minimum requirement of Local content is 22% to avail Purchase Preference Linked with Local Content Policy-2017.

Note:

While evaluating the bids, for price matching opportunities and distribution of quantities among bidders, the order of precedence shall be as under:

1. MSE bidder (PPLC-2012)
2. PP-LC complied bidder (PP-LC)

The bidder claiming the PP-LC benefit shall be required to furnish an undertaking on bidder's latter head confirming his meeting the Local Content and this undertaking shall be certified as under:

- Where the total quoted value is less than INR 5 Crore.



The LC content shall be self-assessed and certified by the authorized signatory of the bidder, signing the bid.

- Where the total quoted value is INR 5 Crore or above:
 - i. The Proprietor and an independent Chartered Accountant, not being an employee of the firm, in case of a proprietorship firm.
 - ii. Any one of the partners and an independent Chartered Accountant, not being an employee of the firm, in case of a partnership firm.
 - iii. Statutory auditors in case of a company. However, where statutory auditors are not mandatory as per laws of the country where bidder is registered, an independent chartered accountant, not being an Employee of the bidder's organization.

65.0 CONDITIONS FOR START-UP COMPANIES

1. Subject to meeting of Quality and Technical specifications, MRPL may consider allowing the participation of all "Start-up" companies (and not limited to manufacturing sector), who are capable of executing the order as per technical specifications/ perform the job as per scope of work specified in the tender and subject to meeting extant & relevant guidelines of Government of India. This should be confirmed and substantiated in the technical bid. The startup bidder shall be required to submit an undertaking along with the bid stating that they will comply with all quality requirement and technical specifications of the tender during execution.
2. To establish the quality and technical specification of the tendered items Technical Capability, following criteria to be ensured as applicable;
 - a) The bidder who intends to participate as "Start-up" company should enclose the Certificate of Recognition issued by Department of Industrial Policy and Promotion (DIPP), Ministry of Commerce & Industry, Govt. of India during submission of Technical bid.
 - b) Nature of Business mentioned in application made to get Start-up accreditation. Nature of Business should be related to tender item.
 - c) A detailed Business Plan covering complete implementation of work with following points needs to be submitted as applicable;
 - Methodology to execute tendered work
 - Resource allocation & planning
 - CV/Qualification of Key executives
 - Working Capital & Finance Management
 - Safety, Security & statutory aspect
 - Any other important points which would be helpful to prove quality & technical capability.
 - d) Certificate of Incorporation.
 - e) Audited Balance sheet (P&L statement) of all the financial year since incorporation.
 - f) The Start-up companies, recognized by DIPP are exempted from payment of EMDs
 - g) Prequalification Criteria with respect to Prior Turnover and Prior Experience may be relaxed for Start-ups as per the GOI guidelines.
 - h) However, there may be circumstances like procurement of items/services related to public safety, health, critical security operations and equipment, etc wherein MRPL reserves the right to not consider relaxation of Prior Turnover and Prior Experience for Start-up Companies as per GOI guidelines.
 - i) Start-up Companies who are also registered as MSEs and wish to avail the benefits as applicable to MSE, shall submit relevant documents covered under Conditions for Micro and Small Enterprises elsewhere in this tender.



ENGINEERING, PROCUREMENT AND CONSTRUCTION MANAGEMENT (EPCM) SERVICES FOR INSTALLATION OF LPG AMINE ABSORBER SYSTEM IN PFCC UNIT AT MRPL, MANGALURU

- j) Based upon above documents / details, if MRPL is not convinced on meeting quality and technical capability of the bidder on the tendered items is able to execute the subject tender, the bid may be rejected without any further notice / communication to the bidder.

Bid Evaluation in case of tie:

- In case of tie at the lowest bid (L1) position between two or more startup/non-startup bidders, the order will be placed on the bidder who has higher/highest turnover in last audited financial year.
- In case there is tie at the lowest bid (L1) position between only startup bidders and none of them has past turnover, the order will be placed on the startup who is registered earlier with Department of Industrial Promotion and Policy.

66.0 POLICY TO PROVIDE PURCHASE PREFERENCE (LINKED WITH LOCAL CONTENT) (PP-LC)

MOP&NG has notified the purchase preference (linked with local content)-PP-LC for the Procurement of goods and services under Oil & Gas Projects in India. Under this Policy, the bidders are allowed to avail the purchase preference linked with attaining the stipulated Local content.

MRPL reserves the right to allow Manufacturers or Suppliers or Service providers, purchase preference as admissible under the prevailing policy, subject to their complying with the requirements/conditions defined herewith and submitting documents required to support the same. In order to avail the Purchase preference under this policy, bidder shall achieve minimum Local Content (LC) for enquiries floated year-wise (Date of Notice inviting tender) as per table given below.

Table of Local Content-Enclosure-1

Items	Local Content (%)		
	2017-18	2018-20	2020-22
Service Contracts	20%	22%	25%
Supply Contracts	20%	22%	25%
EPC Contracts (others)	30%	35%	40%

Notes

1. Above policy is not applicable for Domestically Manufactured Electronic Products (DMEP) and MSME as there being specific policies for products/services
2. The prescribed local content in above table shall be applicable on the date of Notice Inviting Tender.

A) Margin of Purchase Preference

The manufacturers/service providers having the capability of meeting/ exceeding the local content targets given above shall be eligible for 10% purchase preference under the policy. i.e where the quoted price of eligible LC manufacturers/LC service providers is within 10% of the lowest price, purchase preference may be granted at the lowest valid price bid.

B) Procedure for availing benefits under Purchase Preference (Make in India Policy)

The option in case of MSE bidders qualifying under both Policies, namely, Purchase Preference under the Public Procurement Policy – 2012 (PPP-2012) for MSE bidders and Purchase Preference Linked with Local Content (PP-LC 2017) shall be exercised as under:



- i. The MSE bidder can avail only one out of the two applicable purchase preference policies, i.e., PP-LC 2017 for PPP-2012 and therefore, bidder will be required to furnish the option under which he desires to avail purchase preference. This option must be declared within the offer and in case bidder fails to do so although he is eligible for both the Policies, MRPL shall evaluate his offer considering PPP- 2012 as the default chosen option.
- ii. In case a MSE bidder opts for preference under PPP-2012, he shall not be eligible to claim benefit under PP-LC 2017 (irrespective of the fact whether he furnishes the details of LC in his offer and this LC meets the stipulated LC criteria).
- iii. In case a MSE bidder opts for purchase preference based on PP-LC 2017, he shall not be entitled to claim benefit of purchase preference benefit as applicable for MSE bidders under PPP-2012. However the exemptions from furnishing Bid security (EMD) shall continue to be available to such a bidder.
- iv. In view of the above
 - a) The bidder's quoted prices against various items of enquiry shall remain valid even in case of splitting of quantities of the items, except in case of items where the quantity cannot be split since these are to be awarded in a Lot or as a package or Group.
 - b) While evaluating the bids, for price matching opportunities and distribution of quantities among bidders, the order of precedence shall be as under:
 - MSE bidder (PPP-2012)
 - PP-LC complied bidder (PP-LC)

In case the bidder has not declared his status as to whether he is an MSE Bidder or PP-LC Bidder during bid submission, then he will be considered as non PP-LC compliant bidder and evaluated accordingly. No further correspondence will be made in this regard.

Examples of Purchase Preference:

Non divisible item

L1 bidder is non MSE, non PP-LC bidder

L2 bidder is PP-LC (**within 10%**)

L3 bidder is MSE bidder (**within 15%**)

MSE bidder shall be given preference to match the L1 price. If L3 bidder matches the L1 price, Order shall be placed on him, otherwise, option for matching the L1 price shall be given to L2 bidder (PP-LC).

Divisible item

L1 bidder is non MSE, non PL-LC bidder

L2 bidder is PP-LC (within 10%)

L3 bidder is MSE bidder (within 15%)

MSE bidder shall be given preference to match the L1 price. If bidder matches the L1 price, order shall be placed on him for the quantity specified in the bidding document. For the balance quantity (i.e. 50% of tendered quantity/value) option for matching the L1 price shall be given to L2 bidder (PP-LC). Balance quantity shall be awarded to natural lowest bidder.

For further clarification, in case an item has quantity 4 nos. then 1 no. can be given to MSE bidder, 2 to PP-LC bidder and left out 01 no. to natural L1 bidder.

Note:

The above two examples are not applicable to the Works Contracts since the Purchase Preference under PPP-2012 is not applicable to works contracts.

- In case lowest bidder is a MSE bidder, the entire work shall be awarded to him without resorting to purchase preference to bidders complying with Local Content.



ENGINEERING, PROCUREMENT AND CONSTRUCTION MANAGEMENT (EPCM) SERVICES FOR INSTALLATION OF LPG AMINE ABSORBER SYSTEM IN PFCC UNIT AT MRPL, MANGALURU

- In case lowest bidder is a PP-LC bidder, purchase preference shall be resorted to MSE bidder as per provisions specified in the enquiry document w.r.t. PPP-2012 only.

The PP-LC Policy shall be implemented in the following manner

Quantum of purchase preference for bidders qualifying under local content (for LC Bidder) meeting minimum local content, subject to accepting L1 Price and tender applicability criteria, referred to as eligible LC bidder as explained under previous sections are stated below.

A. For goods

- 1) If L-1 is LC bidder, entire quantity will be awarded to such LC bidder
- 2) If L-1 is non-LC bidder,
 - a) 50% of the quantity will be awarded to LC bidder and rest to non-LC bidder
 - b) If quantity cannot be split in the ratio of 50:50, the next higher quantity greater than 50% that is practically splittable shall be awarded to LC bidder and rest to non-LC bidder
 - c) If quantity is indivisible, 100% shall be awarded to LC bidder
 - d) If there are more than one LC bidders, 50% quantity shall be awarded to lowest LC bidder and rest to non LC bidder

B. For Services/ EPC contracts.

Normally the service / EPC contract are not splittable and therefore the eligible LC bidder shall be awarded 100% of the contract. However, in cases where the contract are splittable the LC bidder shall be awarded contract as explained under section A.2) above as in procurement of goods.

C) CERTIFICATION OF LOCAL CONTENT

Manufacturers of goods and/or providers of service, seeking Purchase preference under the policy, shall be obliged to certify the LC of goods, service or EPC contracts as under:

At bidding stage:

The bidder shall provide the percentage local content in the bid (Unpriced Bid)

The bidder must have LC in excess of the requirement specified in table given in Enclosure-1

- The bidder shall submit an undertaking from the authorized signatory of the bidder having **the power of attorney** along with the bid stating the bidder meets the mandatory minimum local content requirement, which shall become part of the contract.
- In cases of procurement for an estimated value in excess of Rs 10 Crores, the undertaking submitted by the bidder shall be supported by a certificate from the **statutory auditor or cost auditor** of the company (in case of companies) or from a **practicing cost accountant or practicing chartered accountant** (in respect of other than companies) **giving the percentage of local content.**
- However, in case of foreign bidder, certificate from the statutory auditor or cost auditor of their own office or subsidiary in India giving the percentage of LC is also acceptable. In case office or subsidiary in India does not exist or Indian office/subsidiary is no required to appoint statutory auditor or cost auditor, certificate from practicing cost accountant or practicing chartered accountant giving the percentage of LC is also acceptable.

After awarding of Contract/Purchase Order

The LC Certificate as per Table attached as per relevant Enclosures (II,III & IV) shall be submitted along with each Invoice as per following criteria



a) Where the total quoted value is less than INR 5 Crore:

In the case of procurement of goods and or services with the value less than Rs Five Crores, the local content shall be calculated (self-assessment) by the supplier of goods and/or the provider of services and certified by the Director/ Authorised representative of the company

b) Where the total quoted value is INR 5 Crore or above -The verification of the procurement of goods, services or EPC contracts with the value Rupees Five Crore and above shall be carried out as follows

- i. The Proprietor and an independent Chartered Accountant, not being an employee of the firm, in case of a proprietorship firm.
- ii. Any one of the partners and an independent Chartered Accountant, not being an employee of the firm, in case of a partnership firm.
- iii. Statutory auditors in case of a company. However, where statutory auditors are not mandatory as per laws of the country where bidder is registered, an independent chartered accountant, not being an Employee of the bidder's organization.

However, procuring company shall also have the authority to audit as well as witness production processes to certify the achievement of the requisite local content and/or to obtain the complete back up calculation before award of work failing which the bid shall be rejected and appropriate action may be initiated against the bidder.

D) CALCULATION AND DETERMINATION OF LOCAL CONTENT

Bidder claiming Local Content have to calculate the LC and indicate the same in the Unpriced Bid and substantiate the calculation while submitting each invoice

1. LC shall be calculated on the basis of verifiable data. In the case of data used in the calculation of LC being non verifiable, the value of LC of the said component shall be treated as nil.
2. Format for calculation of LC is enclosed as

- a) Enclosures II, for procurements of
 - a. Supply of goods
 - i) Supply of goods along with installation and commissioning
 - ii) Supply of goods along with installation , commissioning & AMC
 - b) Enclosure III for calculation of LC for Services
 - c) Enclosure IV for calculation of LC for EPC

3. Determination of Local Content

- a) For Goods/installation & commissioning/AMC as evaluated under Enclosure II
 - i. LC of goods shall be computed on the basis of the cost of domestic components in goods, compared to the whole cost of product. The whole cost of product shall be constituted of the cost spent for the production of goods, covering: direct component (material) cost; direct manpower cost, factory overhead cost and shall exclude profit, company overhead cost and taxes for the delivery of goods.
 - ii. The criteria for determination of local content cost shall be as following
 - In the case of direct component (material) based on country of Origin
 - In the case of manpower, based on INR component
 - In the case of working equipment/facility, based on the country of Origin
 - iii. The calculation of LC of the combination of several kinds of goods shall be based on the ratio of the sum of the multiplication of LC of each goods with the acquisition price of each goods to the acquisition price of the combination of goods

- b) For services as evaluated under Enclosure III



ENGINEERING, PROCUREMENT AND CONSTRUCTION MANAGEMENT (EPCM) SERVICES FOR INSTALLATION OF LPG AMINE ABSORBER SYSTEM IN PFCC UNIT AT MRPL, MANGALURU

- I) LC of service shall be calculated on the basis of the ratio of service cost of domestic component in service to the total cost of service
- II) The total cost of service shall be constituted of the cost spent for rendering of service covering
 - Cost of component (material) which is used
 - Manpower and consultant cost, cost of working equipment/facility and
 - General service cost excluding profit, company overhead cost , taxes and duties
- III) The criteria for determination of cost of local content in the service shall be as follows
 - In the case of material being used to help the provision of service, based on country of origin
 - In the case of manpower and consultant based on INR component of the services contract
 - In the case of working equipment/facility, based on the country of Origin and
 - In the case of general service cost, based on the criteria mentioned under 3.b)III above
 - Indian flag vessels in operation as on date
- c) LC of EPC contracts given under Enclosure IV
 - I) LC of EPC contracts shall be ratio of the whole cost of domestic components in the combination of goods and services to the whole combined cost of goods and services
 - II) The whole combined cost of goods and services shall be the cost spent to produce the combination of goods and services, which is incurred on work site.LC of the combination of goods and services shall be counted in every activity of the combination work of goods and services
 - III) The spent cost as mentioned above(3.c.II) shall include production cost in the calculation of LC of goods as mentioned in 3.a.I and service cost in the calculation of LC of services as mentioned in clause 3.b.II
- d) Determination of LC of the working equipment/facility shall be based on the following provision. Working equipment produced in the country is valued as 100% local content and working equipment produced abroad is valued as Nil Local Content (0%)
- e) As regards cases where currency quoted by the bidder is other than INR, exchange rate prevailing on the date of Tender (NIT) shall be considered for the calculation of LC

The onus of submission of appropriately certified documents lies with the bidder and purchaser shall not have any liability to verify the contents & will not be responsible for same.

However, in case the procuring company has any reason to doubt the authenticity of the Local Content, it reserves the right to obtain the complete back up calculations before award of work failing which the bid shall be rejected.

E) Failure of bidder in complying with the local content post award:

In case a bidder, who has specified in his bid that the bid meets the minimum Local Content specified in the enquiry document fails to achieve the same the following actions shall be taken by the procuring company:

- a. Pre-determined penalty @ 10% of total contract value.
- b. Banning business with the supplier/contractor for a period of one year



ENGINEERING, PROCUREMENT AND CONSTRUCTION MANAGEMENT (EPCM) SERVICES FOR INSTALLATION OF LPG AMINE ABSORBER SYSTEM IN PFCC UNIT AT MRPL, MANGALURU

To ensure the recovery of above pre-determined penalty, payment against dispatch/shipping document shall be modified to the extent that the 10% payment out of this milestone payment shall be released after completion of this milestone as well as submission of certification towards achievement of Local Content, as per provision of enquiry document. Alternatively, this payment can be released against submission of additional bank guarantee valid till completion Schedule Plus 3 months or as required by purchasing company.

Enclosure-II

CALCULATION OF LOCAL CONTENT – GOODS

Name of Manufacturer	Calculation by manufacturer			
	Cost per one unit of product			
Cost component	Cost (Domestic component) a	Cost (Imported component) b	Cost Total Rs/US\$ C=a+b	% Domestic component d=a/c
I. Direct material cost				
II. Direct labour Cost				
III. Factory overhead				
IV. Total production cost				

Note:

$$\% \text{ LC Goods} = \frac{\text{Total cost (IV.c)} - \text{Total imported component cost (IV.b)}}{\text{Total Cost (IV.c)}} \times 100$$

$$\% \text{ LC Goods} = \frac{\text{Total domestic component cost (IV.a)}}{\text{Total Cost (IV.c)}} \times 100$$



Enclosure-III

CALCULATION OF LOCAL CONTENT – SERVICE

NAME OF SUPPLIER OF GOODS/PROVIDER OF SERVICE							
			Cost Summary				
			Domestic	Imported Rs/US\$	Total	LC	
						%	Rs/US\$
			b	c	d	e=b/d	f=d x e
A	Cost component						
	I. Material used cost	Rs US\$					
	II. Personnel & Consultant cost	Rs US\$					
	III. Other services cost	Rs US\$					
	IV. Total cost (I to IV)	Rs US\$					
B	Taxes and Duties	Rs US\$					
C	Total quoted price	Rs US\$					

Note:

$$\% \text{ LC Service} = \frac{\text{Total cost (A. IV. d)} - \text{Total imported component cost (A. IV. c)}}{\text{Total Cost (A. IV. d)}} \times 100$$

$$\% \text{ LC Service} = \frac{\text{Total domestic component cost (A. IV. b)}}{\text{Total Cost (A. IV. d)}} \times 100$$



**ENGINEERING, PROCUREMENT AND CONSTRUCTION MANAGEMENT (EPCM) SERVICES FOR
INSTALLATION OF LPG AMINE ABSORBER SYSTEM IN PFCC UNIT AT MRPL, MANGALURU**

Enclosure-IV

CALCULATION OF LOCAL CONTENT –EPC (GOODS AND SERVICE)

A.	COST COMPONENT (Rs/US\$)	Cost Summary				
		Domestic	Imported Rs/US\$	Total	LC	
					%	Rs/US\$
		b	c	d	e=b/d	f=d x e
I	GOODS					
1.	Material used cost					
2.	Equipment cost					
3.	Sub Total I					
II	SERVICES					
1.	Personnel & Consultant Cost					
2.	Equipment & WorkFacility Cost					
3.	Construction/Fabrication Cost					
4.	Other Services Cost etc					
5.	Sub Total II					
III.	TOTAL COST GOODS + SERVICES					
B.	Non Cost Component					
C.	TOTAL QUOTED PRICE					

Note:

% LC Combination =

$$\frac{\{\text{Total domestic component cost of goods (AI3b)} + \text{Total domestic component cost of service (AII5b)}\}}{\text{Total Cost (AIII d)}} \times 100$$



Domestically Manufactured Electronic Items (DMEP)

Ministry of Electronics and IT (MeITy) has specified the preference to local content in Domestically Manufactured Electronics Items as follows:

Electronic Items	Local Content	Purchase Preference
1. Desktop computers	45%	50%
2. Laptop personal computers	40%	50%
3. Tablet personal computers	45%	50%
4. Dot-matrix printers	55%	50%
5. Smart cards-contact type	65%	50%
6. Smart cards-contactless type	70%	50%
7. LED products	65%	50%
8. Biometric Access control/authentication	45%	50%
9. Biometric fingerprint sensors	45%	50%
10. Biometric Iris Sensors	45%	50%
11. Servers	40%	50%

Certification of Local Content For electronics goods

It is mandatory for the bidder should submit a certificate duly certified by a practicing cost accountant/chartered account, in line with the said along with prescribed Form (enclosed) in the technical bid, mentioning the location(s) at which local value addition is made. In case of companies, the certification shall be from the statutory auditor or cost auditor for the company. In case the procurement value is <Rs 10Crores self-certification is acceptable.

The bidder claiming benefits of Purchase Preference on the above shall provide at least 2 sets of data each under the following heads.

1. Domestic Bill of Materials

- a) Sum of the costs of all the inputs which go into the product (including duties and taxes levied on procurement of inputs except those for which credit/setoff can be taken) and which have not been imported directly or through a domestic trader or a intermediary
- b) Ex-factory price of product minus profit after tax minus sum of imported bill of material used (directly or indirectly) as inputs in producing the product (including duties and taxes levied on procurement of inputs except those for which credit/setoff can be taken) minus warranty costs
- c) Market price minus post production freight, insurance and other handling cost minus profit after tax minus warranty cost minus sum of imported bill of material used as inputs in producing the product(including duties and taxes levied on procurement of inputs except those for which credit/setoff can be taken) minus sales and marketing expenses

2. Total Bill of Materials

- a) Sum of the costs of all the inputs which go into the product (including duties and taxes levied on procurement of inputs except those for which credit/setoff can be taken)
- b) Ex-factory price of product minus profit after tax, minus warranty costs
- c) Market price minus post production freight, insurance and other handling cost minus profit after tax minus warranty cost minus sales and marketing expenses.

The percentage domestic value addition shall be calculated as per the following formula,

% Domestic Value addition = Domestic Bill of Material/Total Bill of Material
under “notification for electronics products under public procurement order 2017” **Public procurement (Preference to Make in India)-order 2017-Notification on Cellular Mobile Phones.**



In furtherance of above order, MeITy has added cellular Mobile Phones vide notification no 33(5)/2017-IPHW dated 1/08/2018 and can be downloaded from http://dipp.nic.in/sites/default/files/Meity_dated_01082018.pdf

Public Procurement (Preference to Make in India) Order 2018 for Cyber Security Products

MeITy has issued notification viz File No 1 (10)/2017-CLSES dated 2/7/2018 to give purchase preference to domestically manufactured /produced Cyber Security Products as per the above Order.

The definition of cyber security product, local supplier of domestically manufactured Cyber Security Products, exclusions, Verifications etc are available under <http://meity.gov.in/cyber-security>

The local supplier at the time of bidding shall provide self-certification that the item offered meets the definition of local supplier of domestically manufactured/ produced Cyber Security Products.

Certification authority for estimated values beyond Rs 10 Crores shall be statutory auditor or cost auditor of the company (in case of companies).

In case of false declarations, provisions under clause-24-Instructions to Bidders of Section-1 of Tender Document will apply. Complaints received against claims of a bidder regarding supply of domestically manufactured Cyber Security Product shall be referred to STQC under MeITy.

For certification of local content in electronic goods shall be as per the circular F.No.33(1)/2017-IPHW issued by Government of India Ministry of Electronics and Information Technology dated 14th September 2017, which may be downloaded from <http://meity.gov.in/esdm/ppo>

Purchase Preference in case where Negotiation is also required:

In case purchase preference is applicable, but negotiation is to be conducted with L1 bidder, negotiation shall be carried out MSE and/or LC-complied bidder shall be offered to match the negotiated prices (even if, post negotiation, they are higher by more than 10% as compared to L1 bidder provided they were within 10% of L1 bidder as per original quoted prices) and left out quantity, if any, as per provisions of enquiry document shall be awarded to that bidder.

Note:

Relevant policy guidelines issued including modifications made from time by the concerned Ministry in respect to Purchase Preference to Make in India, shall be applicable.

67.0 TERMS AND CONDITIONS FOR BIDDERS FROM A COUNTRY SHARING LAND BORDERS WITH INDIA.

This is in line with Office Memorandum (OM) no. 6/18/2019-PPD dtd. 23rd July 2020 inserting Rule 144 (xi) in GFRs (General Finance Rules) 2017 issued by “Department of Expenditure, Public Procurement Division, Ministry of Finance”.

Bidders should ensure compliance to the following clauses of the OM no. 6/18/2019-PPD dated 23rd July 2020:

- I. Any bidder from a country which shares a land border with India will be eligible to bid in This tender only if the bidder is registered with the Competent Authority.



- II. "Bidder" (including the term 'tenderer', 'consultant' or 'service provider' in certain contexts) means any person or firm or company, including any member of a consortium or joint venture (that is an association of several persons, or firms or companies), every artificial juridical person not falling in any of the descriptions of bidders stated hereinbefore, including any agency branch or office controlled by such person, participating in a procurement process.
- III. Bidder from a country which shares a land border with India" for the purpose of this Order means: -
- An entity incorporated, established or registered in such a country; or
 - A subsidiary of an entity incorporated, established or registered in such a country; or
 - An entity substantially controlled through entities incorporated, established or registered in such a country; or
 - An entity whose beneficial owner is situated in such a country; or
 - An Indian (or other) agent of such an entity; or
 - A natural person who is a citizen of such a country; or
 - A consortium or joint venture where any member of the consortium or joint venture falls under any of the above.
- IV. The beneficial owner for the purpose of (iii) above will be as under:
- In case of a company or Limited Liability Partnership, the beneficial owner is the natural person(s), who, whether acting alone or together, or through one or more juridical person, has a controlling ownership interest or who exercises control through other means. Explanation—
 - Controlling ownership interest" means ownership of or entitlement to more than twenty-five per cent. Of shares or capital or profits of the company;
 - Control" shall include the right to appoint majority of the directors or to control the management or policy decisions including by virtue of their shareholding or management rights or shareholders agreements or voting agreements;
 - In case of a partnership firm, the beneficial owner is the natural person(s) who, whether Acting alone or together, or through one or more juridical person, has ownership of entitlement to more than fifteen percent of capital or profits of the partnership;
 - In case of an unincorporated association or body of individuals, the beneficial owner is the natural person(s), who, whether acting alone or together, or through one or more juridical person, has ownership of or entitlement to more than fifteen percent of the property or capital or profits of such association or body of individuals;
 - Where no natural person is identified under (1) or (2) or (3) above, the beneficial owner is the relevant natural person who holds the position of senior managing official;
 - In case of a trust, the identification of beneficial owner(s) shall include identification of the author of the trust, the trustee, the beneficiaries with fifteen percent or more interest in the trust and any other natural person exercising ultimate effective control over the trust through a chain of control or ownership.
- V. An Agent is a person employed to do any act for another, or to represent another in dealings with third person.
- VI. [For Works contracts, including Turnkey contracts] The successful bidder shall not be allowed to sub-contract works to any contractor from a country which shares a land border with India unless such contractor is registered with the Competent Authority.

Following relevant Certificate(s), as applicable, to be submitted by the bidder along with the bid :

Certificate for Tenders (where Sub-contracting is not involved):

"I have read the clause regarding restrictions on procurement from a bidder of a country which shares a land border with India; I certify that this bidder is not from such a country or, if from such a country, has been registered with the Competent Authority. I hereby certify that this bidder fulfils all requirements in this regard and is eligible to be considered, for submitting their bid for the Tender no.....of your Organisation."

[Where applicable, evidence of valid registration by the Competent Authority shall be attached]



Certificate for Tenders for Works involving possibility of sub-contracting:

"I have read the clause regarding restrictions on procurement from a bidder of a country which shares a land border with India and on sub-contracting to contractors from such countries; I certify that this bidder is not from such a country or, if from such a country, has been registered with the Competent Authority and will not sub-contract any work to a contractor from such countries unless such contractor is registered with the Competent Authority. I hereby certify that this bidder fulfils all requirements in this regard and is eligible to be considered, for submitting their bid for the Tender no.....of your Organisation."

[Where applicable, evidence of valid registration by the Competent Authority shall be attached]

Certificate for GeM:

"I have read the clause regarding restrictions on procurement from a bidder of a country which shares a land border with India; I certify that this vendor/ bidder is not from such a country or, if from such a country, has been registered with the Competent Authority. I hereby certify that this vendor/ bidder fulfills all requirements in this regard and is eligible to be considered for procurement on GeM, for submitting their bid for the Tender no.....of your Organisation."

[Where applicable, evidence of valid registration by the Competent Authority shall be attached]

EXHIBIT 9

REMUNERATION, CONTRACT PRICE AND TERMS OF PAYMENT

Consultant's Remuneration: In consideration of Consultant's agreeing to perform the Work in accordance with this Contract, Owner shall pay to Consultant the Contract Price, subject to such adjustments as are herein or otherwise in the contract document specified but otherwise without any adjustment, increase or discount. Details of the contract price is contained in Exhibit – 11.

1.0 REMUNERATION

- 1.1** Consultant's lump sum price for its scope of services, schedule and terms and conditions to be performed as per this contract shall be as per Exhibit –11 FORM SP-0.
- 1.2** The lumpsum price above shall be inclusive of all the expenses for performance of the scope of work. The cost shall include travel cost (Includes inland, local, boarding, lodging etc.), administrative expenditures, mobilization and demobilization charges etc. The lumpsum price is also inclusive of all travel costs and associated expenses of bidder's overseas personnel to India / Other countries in case required.
- 1.3** Consultant's lump sum price in Para 1.1 shall be exclusive of all foreign travels. (Visits for all foreign inspection and expediting as may be desired by MRPL also are excluded).
- 1.4** Price shall be inclusive of all the taxes, duties, charges towards all other expenses, etc., for satisfactory completion of the work / Services, except Good and Service Tax (GST) which shall be payable extra at actuals. GST shall be extra at actuals to MRPL Account. Bidder shall confirm the applicable Service Tariff Code SAC / HSN as per GST
- 1.5** Prices quoted by the bidder shall remain firm and fixed and valid until completion of the all the services as per the contract.
- 1.6** However, Consultant shall be entitled for additional compensation for services as per diem rates / man month rates as quoted separately in **FORM SP-1** for:
 - a. Scope of services for the extended period beyond contractual completion date of the Project, for reasons not attributable to Consultant, subject to submission of Deployment schedule, certified Time sheets / attendance sheets of the manpower deployed for the Services, as required by Owner.
 - b. Any additional services desired by MRPL beyond the agreed scope.
 - c. Providing assistance to MRPL, as per cl 47 under D.1-Scope of Service of Exhibit-2, beyond two years after Mechanical completion of the facilities covered in this contract.
 - d. Foreign travel
- 1.7** The rates shall be subject to the following:
 - a. The per diem rates / man month rates shall be exclusive of all applicable statutory taxes / levies / cess. In case any tax, cess, levy, impost is levied in India or outside India (for foreign travels) on payments to Consultant, the same will be payable by MRPL as applicable.
 - b. Consultant's per diem charges / man month rates shall be payable for all days starting from the day of arrival at the destination city and shall terminate with the day of departure there from the city of the visit in case of working out of home / office.
 - c. The per diem rates / man month rates shall be inclusive of travel costs in India and its associated expenses such as lodging, boarding, living allowance all local transport, visa / work permit and medical insurance
 - d. In case of foreign travel, the per diem rates / man month rates are exclusive of travel (air travel economy class) costs and its associated expenses, such as lodging, boarding, living allowance, transport, visa / work permit and medical insurance and the same shall be reimbursed in line with MRPL foreign travel rules.



- e. Consultant's per diem rates / man month rates shall be based on a normal working of 8 hours a day and 6 days a week. Any extra hours worked shall be charged on pro-rata basis
- f. For additional work extending more than 30 calendar days, man month rate will be considered for payment.
- g. Optional Manpower Rates quoted shall be valid up to 31.12.2023. Rate of escalation as quoted will be applicable from 01.01.2024

1.8 Rate of Escalation shall be applicable as quoted in terms of percentage in FORM SP-1.

2.0 TERMS OF PAYMENT

CONSULTANT's lump sum fees shall be paid as per the following on monthly basis upon submission of the bill. One bill per month is only allowed.

Lump sum fee towards CONSULTANT Services

- a. 5% - After Kick-off Meeting
 - b. 5% - After Submission of Feed document and Cost estimate
 - c. 20% - On prorata basis on receipt of price bid opening recommendation of all MR/RFQ/NIT
 - d. 10%- On prorata basis on receipt of items/materials at site
 - e. 35% - On prorata basis on construction work progress at site
 - f. 10% - On Mechanical Completion
 - g. 5% - On Commissioning and PGTR completion
 - h. 5% - On Submission of final documentation
 - i. 5% - On Completion of all the services and on final closure of contract
- i. For reimbursable fees / rate charges, 100% payment will be on monthly basis.
 - ii. Billing breakup shall be worked out on for stage payment on mutually agreement.
 - iii. Effect of Payment: The making of any payment shall in no event constitute the acceptance by MRPL of any Work performed by Consultant pursuant to this contract.



**EXHIBIT 10
BG FORMAT FOR EMD & PBG**

The irrevocable Bank Guarantee (BG) in the prescribed format if submitted against Earnest Money Deposit shall be subject to verification from the issuing Bank, the email ID of bank for the same must be incorporated in the BG.

The BG issued by the issuing Bank on behalf of Bidder/Contractor/Supplier in favour of "Mangalore Refinery and Petrochemicals Limited" shall be in paper form and also be made available under the "Structured Financial Messaging System" (SFMS).

A separate advice of the BG will invariably be sent by the issuing bank to the beneficiary's Bank through SFMS and SFMS transmission message reference number (currently 32 digits code) is to be sent along with BG directly to MRPL through speed post/regd. Post.

The details of beneficiary for issue of BG under SFMS platform is furnished below:

Name of Beneficiary: Mangalore Refinery and Petrochemicals Limited
Beneficiary Bank, Branch and address: Union Bank of India (Erstwhile Corporation Bank), MRPL Project Site, Kuthethoor Post Mangaluru 575030, Karnataka
IFSC code: CORP0000592
SWIFT Code: CORPINBB
MICR Code: 575017015

Any bank guarantee submitted in physical mode which cannot be verifiable through SFMS will not be accepted under any circumstances.

PROFORMA OF BANK GUARANTEE FOR SECURITY DEPOSIT/PERFORMANCE BOND

(To be executed ON NON-JUDICIAL STAMP PAPER OF APPROPRIATE VALUE)

Ref: Bank Guarantee No.....
Date.....

To:

M/s. Mangalore Refinery And Petrochemicals Ltd.,
Regd. Office: Kuthethur P.O
Katipalla, Mangalore 575 030

Dear Sir,

1. In consideration of Mangalore Refinery And Petrochemicals Ltd., having its Registered Office at..... (hereinafter referred to as the "Company" which expression shall unless repugnant to the context or meaning thereof, include all its successors, administrators, executors) and having entered into a contract dated (hereinafter called the "Contract" which expression shall include all the amendments thereto) with M/s.having its Head/Registered Office at.....(hereinafter referred to as the "Contractor" (which expression unless repugnant to the context or meaning thereof, shall include all its successors, administrators, executors and assigns) and the contract having been unequivocally accepted by the Contractor resulting in a contract bearing No..... dated..... Valued at for (scope of work) and the Company having agreed that the Contractor shall furnish to the Company a performance guarantee for the faithful performance of the entire contract to the extent of % of the contract price, i.e. Rs..... (in word) we (bank)..... having its Registered Office at.....



.....(hereinafter referred to as the “Bank” which expression shall unless repugnant to the context or meaning thereof, include all its successors, administrators, executors and assigns) do hereby guarantee and undertake to pay on demand to the Company any money or all moneys to the extent of Rs..... (Rupees) in aggregate at any time without any demur, reservation, recourse, contest or protest and/or without any reference to the Contractor. Any such demand made, by the Company on the Bank shall be conclusive and binding notwithstanding any difference between the Company and the Contractor or any dispute pending before any Court, Tribunal, Arbitrator or any other authority. We agree that Guarantee herein contained shall be irrevocable and shall continue to be enforceable till it is discharged by the Company in writing.

2. The Company shall have the fullest liberty, without affecting in any way the liability of the Bank under this Guarantee from time to time, to extend the time for performance of the contract by the Contractor, or vary the terms of the Contract. The Company shall have the fullest liberty without affecting this Guarantee to postpone, from time to time, the exercise of power vested in them or of any right which they might have against the Contractor and to exercise the same at any time in any manner and either to enforce, or to forbear from enforcing, any covenants contained or implied in the contract between the Company and the Contractor or any other course or remedy or security available to the Company. The Bank shall not be released of its obligations under these presents by any exercise by the Company of its liberty with reference to matters aforesaid or any of them or by reason of any other act or forbearance or other act or forbearance of other acts of Company or any other indulgence shown by the Company or by any other matter or thing whatsoever, which under law would, but for this provision, have the effect of relieving the Bank.
3. The Bank also agrees that the Company at its option shall be entitled to enforce this Guarantee against the Bank as a principal debtor, in the first instance, without proceeding against the Contractor and notwithstanding any security or other guarantee that Company may have in relation to the Contractor’s liabilities.
4. The Bank further agrees that the guarantee herein contained shall remain in full force during the period that is taken for the performance of the contract and it shall continue to be enforceable till all the dues of the Company under or by virtue of this contract have been fully paid and claim satisfied or discharged or till the Company discharges the Guarantee in writing.
5. We further agree that as between us and Company for the purpose of this Guarantee any notice given to us by the Company and any amount claimed in such notice by the Company that the money is payable by the Contractor and any amount claimed in such notice by the Company shall be conclusive and binding on us notwithstanding any difference between the Company and the Contractor or any dispute pending before any Court, Tribunal, Arbitrator or any other authority. We further agree that this Guarantee shall not be affected by any change in our Constitution or that of the Contractor or in the Constitution of the Company. We also undertake not to revoke this Guarantee during its currency.



ENGINEERING, PROCUREMENT AND CONSTRUCTION MANAGEMENT (EPCM) SERVICES FOR INSTALLATION OF LPG AMINE ABSORBER SYSTEM IN PFCC UNIT AT MRPL, MANGALURU

6. Notwithstanding anything contained hereinabove, our liability under this Guarantee is limited to Rs..... (Rupees) in aggregate and it shall remain in full force upto and including sixty days after unless extended further, from time to time, for such period as may be instructed in writing by M/S..... on whose behalf this Guarantee has been given, in which case it shall remain in full force upto and including 60 days after extended date. Any claim under this Guarantee must be received by us before the expiry of the 90 days from or before the expiry of the 90 days from the extended date. If no such claim has been received by us within the sixty days after the said date/extended date, the Company's right under this guarantee will cease. However, if such a claim has been received by us within and upto ninety days after the said date/extended date, all the Company's rights under this Guarantee shall be valid and shall not cease until we have satisfied that claim.

The bank doth hereby that Shri (designation) Who is authorized this Guarantee / Undertaking on behalf of the bank and to bind the bank thereby Dated this Day of200....

WITNESS:

(SIGNATURE)

(SIGNATURE)

(NAME)

(NAME)

(OFFICIALADDRESS)

(Designation with Bank Stamp)

_____ Attorney as per power of

Attorney No.....

Dated:.....



PROFORMA OF BANK GUARANTEE

(FOR EARNEST MONEY DEPOSIT AS APPLICABLE)
(On non-judicial paper of appropriate value)

To
Mangalore Refinery and Petrochemicals Limited
Mangalore

Dear Sirs,

In consideration of Mangalore Refinery and Petrochemicals Limited, having its Registered Office at Kuthethoor P.O Via Katipalla, Mangalore - 575030 (hereinafter called "the Owner" which expression shall include its successors and assigns), having agreed inter alia to consider the tender of (Name of the Tenderer) having its Head Office/Registered Office at (Address of the Tenderer) (hereinafter called the "Tenderer" which expression shall include its successors and assigns), for the work of..... (Name of the Project/ Work) at..... to be awarded under Tender No..... Upon the Tenderer furnishing an undertaking from the Bank as hereinafter appearing in lieu of cash deposit of the Earnest Money.

We (Name of the Bank), a Bank Constituted/Registered under the Act, having our Head Office/Registered Office at (hereinafter called the "Bank" which expression shall include its successors and assigns), at the request of the Tenderer and with the intent to bind the Bank and its successors and assigns do hereby unconditionally and irrevocably undertake to pay the Owner at Mangalore forthwith on first demand without protest or demur or proof or satisfaction or condition and without reference to the Tenderer, all sums payable by the Tenderer as and by way of Earnest Money to the Owner, upto an aggregate limit of (Amount in figures and words).

AND THE BANK DOTH HEREBY FURTHER AGREES AS FOLLOWS:

1. This Guarantee/Undertaking shall be a continuing guarantee and shall remain in full force and effect for all claims and demands made by the Owner on the Bank until the Owner discharges this Guarantee/Undertaking subject, however, that the Owner shall have no claims under this Guarantee/Undertaking after the midnight of200..... or any written extension(s) thereof.

PROVIDED that if the aforesaid work tendered for or any part thereof shall be awarded to the Tenderer on or before the said date, whether on the basis of accompanying tender or any other basis, then the validity of this guarantee/undertaking shall stand automatically extended for all claims and demands made by the Owner for further three months.

2. The Owner shall have the fullest liberty without reference to the Bank and without affecting in any way the liability of the Bank under this Guarantee/Undertaking at any time and/or from time to time any wise to postpone and/or vary any of the powers, rights, and obligations exercisable by the Owner against the Tenderer and either to enforce or to forbear from enforcing all or any of the terms and conditions of or governing the said Tender and/or any contract consequent upon any award of work or the said Earnest Money Deposit or the securities available to the Owner or any of them and the Bank shall not be released from its liability under these Presents and the Liability of the Bank hereunder shall remain in full force and effect notwithstanding any exercise by the Owner of the liberty with reference to any or all the matters aforesaid or by reason of any other act, matter or thing whatsoever which under law relating to the sureties or otherwise which could, but for this provision have the effect of releasing the Bank from all or any of its obligations hereunder or any part thereof, and the Bank specifically waives any and all contrary rights whatsoever.

3. It shall not be necessary for the Owner to proceed against the Tenderer before proceeding against the Bank and the Guarantee/Undertaking herein contained shall be enforceable



**ENGINEERING, PROCUREMENT AND CONSTRUCTION MANAGEMENT (EPCM) SERVICES FOR
INSTALLATION OF LPG AMINE ABSORBER SYSTEM IN PFCC UNIT AT MRPL, MANGALURU**

against the Bank as principal debtor notwithstanding the existence of any other undertaking or security for any indebtedness of the Tenderer to the Owner and notwithstanding that any such security shall at the time when claim is made against the Bank or proceedings taken against the Bank hereunder, be outstanding or unrealised.

4. The amount stated by the Owner in any demand, claim or notice made with reference to this guarantee shall as between the Bank and the Owner for the purpose of these Presents be conclusive of the amount payable by the Bank to the Owner hereunder.
5. The liability of the Bank to the Owner under this Guarantee/Undertaking shall remain in full force and effect notwithstanding the existence of any difference or dispute between the Tenderer and the Owner, the Tenderer and the Bank and/or the Bank and the Owner or otherwise howsoever touching these Presents or the liability of the Tenderer to the Owner, and notwithstanding the existence of any instructions or purported instructions by the Tenderer or any other person to the Bank not to pay or for any cause withhold or defer payment to the Owner under these Presents, with the intent that notwithstanding the existing of such difference, dispute or instructions, the Bank shall be and remain liable to make payment to the Owner in terms thereof.
6. This Guarantee/Undertaking shall not be determined or affected by the liquidation or winding up or dissolution or change of constitution or insolvency of the Tenderer or any change in the legal constitution of the Bank or the Owner.
7. Without prejudice to any other mode of service, a demand or claim or other communication may be transmitted by the Owner to the Bank either by post or by fax. If transmitted by fax, the transmission shall be complete as soon as acknowledged by the Bank.
8. Notwithstanding anything contained herein:
 - i. The Bank's liability under this guarantee/undertaking shall not exceed (Amount in figures & words);
 - ii. The guarantee/undertaking shall remain in force upto_____ and any extension(s) thereof; and
 - iii. The Bank shall be released and discharged from all liability under this guarantee/undertaking unless a written claim or demand is issued to the Bank on or before_____ or the date of expiry of any extension(s) thereof if this guarantee/undertaking has been extended.

The Bank doth hereby declare that Shri_____ (designation)_____ who is authorised to sign this Guarantee/Undertaking on behalf of the Bank and to bind the Bank thereby.

This_____ day of_____ 20_____.

Yours faithfully

Signature: _____
Name & Designation: _____
Name of the Branch: _____



EXHIBIT 11

SUMMARY OF SCHEDULE OF PRICES

PRICE BID FORMAT

**ENGINEERING, PROCUREMENT AND CONSTRUCTION
MANAGEMENT (EPCM) SERVICES FOR INSTALLATION OF
LPG AMINE ABSORBER SYSTEM IN PFCC UNIT AT MRPL,
MANGALURU.**

Tender No.: 3200000464



ENGINEERING, PROCUREMENT AND CONSTRUCTION MANAGEMENT (EPCM) SERVICES FOR INSTALLATION OF LPG AMINE ABSORBER SYSTEM IN PFCC UNIT AT MRPL, MANGALURU



**Mangalore Refinery and Petrochemicals Limited
(A subsidiary of Oil and Natural Gas Corporation Limited)**

Instructions to Bidders: Please Complete all the Highlighted Cells before submission

FORM SP-0

Tender No: 3200000464

Tender Description: ENGINEERING, PROCUREMENT AND CONSTRUCTION MANAGEMENT (EPCM) SERVICES FOR INSTALLATION OF LPG AMINE ABSORBER SYSTEM IN PFCC UNIT AT MRPL, MANGALURU

Name of Tenderer:

SI	Description of items	UOM	Qty	Service Tarrif Code *	Unit Rate in INR	Amount in INR
1	TOTAL LUMP SUM PRICE for EPCM Consultancy services for Detailed Engineering, Procurement and Construction management, Mechanical Completion and Commissioning of LPG Amine Absorber System in PFCC Unit at MRPL as per Tender 3200000464 . This shall include but not limited to Project Management, Detailed Engineering, Procurement Services, Inspection and Expediting, Construction Supervision of required facilities. The scope includes but not limited to Civil, Structural, Architectural, UG piping, Mechanical, Piping, Electrical, Instrumentation, Insulation, Painting, Assistance in obtaining statutory clearance, Assistance during Pre-commissioning, Start-up, Commissioning and performance test for new / revamped equipment, final documentation and closure of all contracts of LPG Amine Absorber System in PFCC Unit as per tender 3200000464.	Lump sum	1	To be quoted in EPS	To be quoted in EPS	0.00
	Total Lumpsum Amount (Rs.) excluding GST (FORM SP-0)					0.00
			GST			0.00
	Total Cost including GST (FORM SP-0)					0.00
	Total Cost including GST (FORM SP-0 + FORM SP-1)					0.00



ENGINEERING, PROCUREMENT AND CONSTRUCTION MANAGEMENT (EPCM) SERVICES FOR INSTALLATION OF LPG AMINE ABSORBER SYSTEM IN PFCC UNIT AT MRPL, MANGALURU

Notes to FORM SP-0 :

1. Prices quoted by the bidder shall remain firm and fixed and valid until completion of the all the services as per the contract.
2. Consultant shall be entitled for additional compensation for services as per diem rates / man month rates as quoted separately in FORM SP-1 for:
 - a. Scope of services for the extended period beyond contractual completion date of the PROJECT, for reasons not attributable to Consultant, subject to submission of Deployment schedule, certified Time sheets / attendance sheets of the manpower deployed for the Services, as required by Owner.
 - b. Any additional services desired by MRPL beyond the agreed scope.
 - c. Providing assistance to MRPL, as per cl 47 under D. 1-Scope of Service of Exhibit-2, beyond two years after Mechanical Completion of the facilities covered in this contract.
 - d. Foreign travel.
3. Quoted Lumpsum price shall be inclusive of all the taxes, duties, charges towards all other expenses, etc., for satisfactory completion of the work / Services, except Good and Service Tax (GST) which shall be payable extra at actuals.
4. GST shall be extra at actuals to MRPL Account. Bidder shall confirm the applicable Service Tariff Code SAC / HSN as per GST.
5. All expenditure related to the scope of work / Service to be included in the quote.
6. Bidders shall clearly mention in the Technical Bid, the various applicable taxes and their rates considered, to be paid by MRPL (without mentioning the actual tax amount).
7. The Price Bid shall clearly mention the applicable tax rates and the tax amounts to be paid by MRPL. Rates of Goods and Services tax should be indicated in terms of percentage on technical bid. The rate of GST on percentage and amount shall clearly mention in the Price Bid.
8. Bidder to refer Taxes and Duties clauses of the tender before quoting.
9. The GST rate / amount indicated by the Bidder in this Form shall include both, namely,
 - (i) The amount of GST payable by the bidder and reimbursable by Owner.
 - (ii) The amount of GST, if any, payable by Owner, as applicable to recipient of service, as per the reverse charge rule of GST.
10. The Bidder's invoice must contain the following:
 - a) HSN / SAC / STC for materials and accounting code for services.
 - b) GSTIN (GST Identification number)
11. Applicable GST as quoted shall be considered for evaluation.
12. Bidder to fill the FORM-SP-1 for Optional rates, same shall be loaded to the Total Lumpsum price as quoted in FORM SP-0 of the Schedule of Prices, to arrive at the landed cost to MRPL, for evaluation.



ENGINEERING, PROCUREMENT AND CONSTRUCTION MANAGEMENT (EPCM) SERVICES FOR INSTALLATION OF LPG AMINE ABSORBER SYSTEM IN PFCC UNIT AT MRPL, MANGALURU



**Mangalore Refinery and Petrochemicals Limited
(A subsidiary of Oil and Natural Gas Corporation Limited)**

FORM SP-1: OPTIONAL MANPOWER RATES

Instructions to Bidders: Please Complete all the Highlighted Cells before submission

Tender No:	3200000464					
Tender Description :	ENGINEERING, PROCUREMENT AND CONSTRUCTION MANAGEMENT (EPCM) SERVICES FOR INSTALLATION OF LPG AMINE ABSORBER SYSTEM IN PFCC UNIT AT MRPL, MANGALURU					
Name of Tenderer :						
A	OPTIONAL PER DIEM AND MAN MONTH RATE (Bidder to Quote valid upto Dec 2023) (Quoted Optional Manpower Rates are considered for evaluation)					
Sl.no	Category of Personnel	A	B	C	D	E
		Quoted Per Diem Rate (in INR)	No. of Days considered for evaluation	Quoted man month Rate (in INR)	No. of Months considered for evaluation	TOTAL (AMOUNT IN INR) = (AXB) + (CXD)
	Consultants Home Office and Other office					
1	Project Manager/Engineering Manager	To be quoted in EPS	30	To be quoted in EPS	1	0.00
2	Lead Engineer /Senior construction supervisor	To be quoted in EPS	30	To be quoted in EPS	1	0.00
3	Design Engineer / Draft person	To be quoted in EPS	30	To be quoted in EPS	1	0.00
4	Construction supervisor / Safety Officer	To be quoted in EPS	30	To be quoted in EPS	1	0.00



ENGINEERING, PROCUREMENT AND CONSTRUCTION MANAGEMENT (EPCM) SERVICES FOR INSTALLATION OF LPG AMINE ABSORBER SYSTEM IN PFCC UNIT AT MRPL, MANGALURU

	At Construction site					
5	Project Manager/Engineering Manager	To be quoted in EPS	30	To be quoted in EPS	1	0.00
6	Lead Engineer /Senior construction supervisor	To be quoted in EPS	30	To be quoted in EPS	1	0.00
7	Design Engineer / Draft person	To be quoted in EPS	30	To be quoted in EPS	1	0.00
8	Construction supervisor / Safety Officer	To be quoted in EPS	30	To be quoted in EPS	1	0.00
	TOTAL AMOUNT OF OPTIONAL MANPOWER RATES CONSIDERED FOR EVALUATION					0.00
	GST					0.00
	TOTAL COST OF OPTIONAL MANPOWER RATES CONSIDERED FOR EVALUATION INCLUDING GST (FORM SP-1)					0.00
B	Escalation percentage for each calendar year beyond 2023 upto 2027					
Sl.no	FOR CALENDAR YEAR	ESCALATION FACTOR (IN PERCENTAGE)				
1	2024	To be quoted in EPS				
2	2025	To be quoted in EPS				
3	2026	To be quoted in EPS				
4	2027	To be quoted in EPS				



ENGINEERING, PROCUREMENT AND CONSTRUCTION MANAGEMENT (EPCM) SERVICES FOR INSTALLATION OF LPG AMINE ABSORBER SYSTEM IN PFCC UNIT AT MRPL, MANGALURU

Notes to FORM SP -1:-

1. Optional manpower rates quoted in FORM SP-1 shall be loaded to the Total Lumpsum price as quoted in FORM SP-0 of the Schedule of Prices, to arrive at the landed cost to MRPL, for evaluation.
2. Consultant shall be entitled for additional compensation for services as per diem rates / man month rates as quoted in this FORM SP-1, for:
 - a. Scope of services for the extended period beyond contractual completion date of the Project, for reasons not attributable to Consultant, subject to submission of Deployment schedule, certified Time sheets / attendance sheets of the manpower deployed for the Services, as required by Owner.
 - b. Any additional services desired by MRPL beyond the agreed scope.
 - c. Providing assistance to MRPL, as per cl 47 under D.1-Scope of Service of Exhibit-2, beyond two years after Mechanical completion of the facilities covered in this contract.
 - d. Foreign travel.
3. The rates shall be subject to the following:
 - a. The per diem rates / man month rates shall be exclusive of all applicable statutory taxes / levies / cess. In case any tax, cess, levy, impost is levied in India or outside India (for foreign travels) on payments to Consultant, the same will be payable by MRPL as applicable.
 - b. Consultant's per diem charges / man month rates shall be payable for all days starting from the day of arrival at the destination city and shall terminate with the day of departure there from the city of the visit in case of working out of home / office.
 - c. The per diem rates / man month rates shall be inclusive of travel costs in India and its associated expenses such as lodging, boarding, living allowance all local transport, visa / work permit and medical insurance
 - d. In case of foreign travel, the per diem rates / man month rates are exclusive of travel (air travel economy class) costs and its associated expenses, such as lodging, boarding, living allowance, transport, visa / work permit and medical insurance and the same shall be reimbursed in line with MRPL foreign travel rules.
 - e. Consultant's above per diem rates / man month rates shall be based on a normal working of 8 hours a day and 6 days a week. Any extra hours worked shall be charged on pro-rata basis
 - f. For additional work extending more than 30 calendar days, man month rate will be considered for payment.
 - g. Optional Manpower Rates quoted shall be valid up to 31.12.2023. Rate of escalation as quoted will be applicable after 31.12.2023
 - h. Rate of Escalation shall be indicated in terms of percentage in figure as well as in words. In case any percentage is not mentioned, then it will be construed that the prices are valid and firm up to 2027.
 - i. It is explained that if any escalation percentage is mentioned in 2024, then it automatically applies to 2025. It means the percentage mentioned in 2025 shall be in addition to the price already increased during 2024 as a result of percentage mentioned in 2024 and so on for other years

Sample calculation for applying escalation assuming Base Price is 1000 Valid up to 31.12.2023.

Price up to 2023=1000

Price in 2024=1000x1.02, Price in 2025=1000x1.02x1.03, Price in 2026=1000x1.02x1.03x1.04, Price in 2027=1000x1.02x1.03x1.04x1.05